

# WAVELINE

## User's Manual

### Model No. WL-YL-2612B

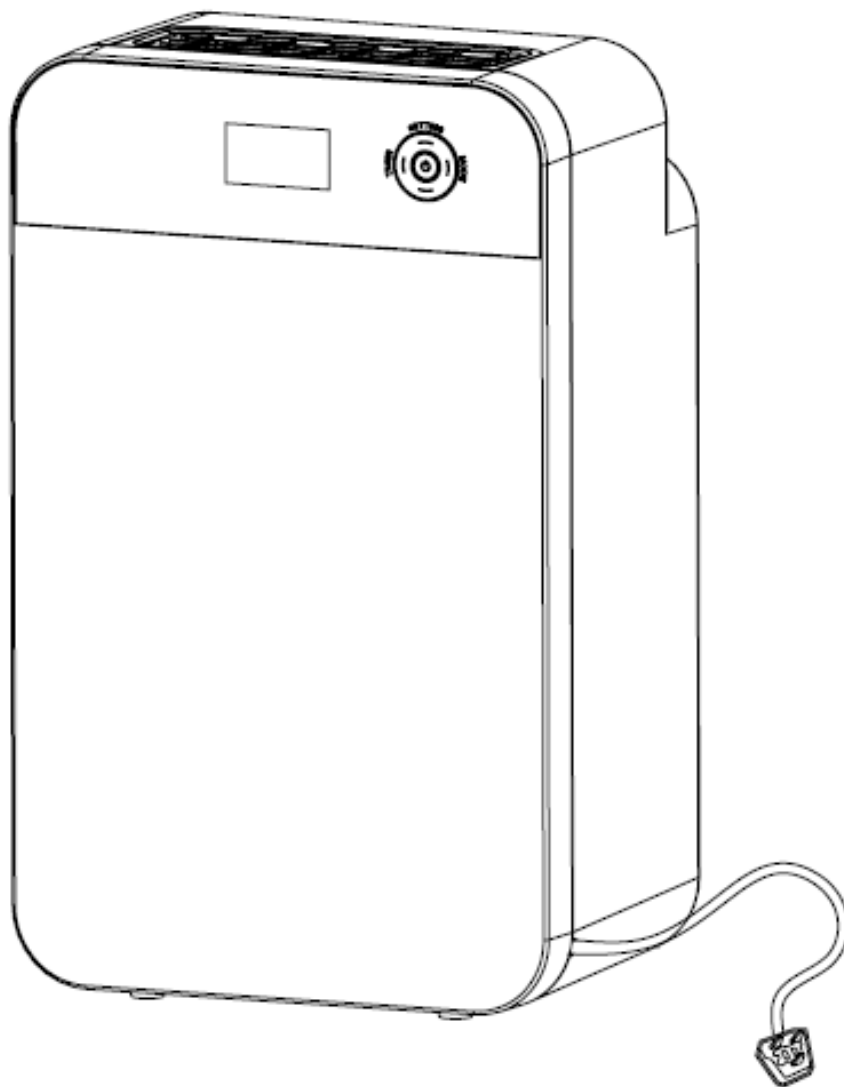

# Index

- Important Safe Guards
  - Ambient Environment For Operating
  - Component Diagrams
  - Operating Introduction
    - Functions of Control Panel & Key Pads
    - LCD Display
    - Operation of Key Pads
    - Automatic Defrosting
    - Water Tank Full Warning
    - Processions Of Abnormal Compressor
    - Protection Of Extremely Low & High Temperature
    - Failure Of Humidity & Temperature Sensor
    - Memory function
    - Continuous Drainage
  - Maintenances & Cleaning
  - Specification
-

# Important Safe Guards



Do not install and use the unit before carefully reading this instruction guide. Please retain this manual for product warranty and future reference.

- 1) Please be sure your electricity is fully working
- 2) To avoid an electric shock, avoid placing the unit near window or in a bathroom.
- 3) To reduce a fire risk, ensure the unit is not placed next to a high temperature appliance.

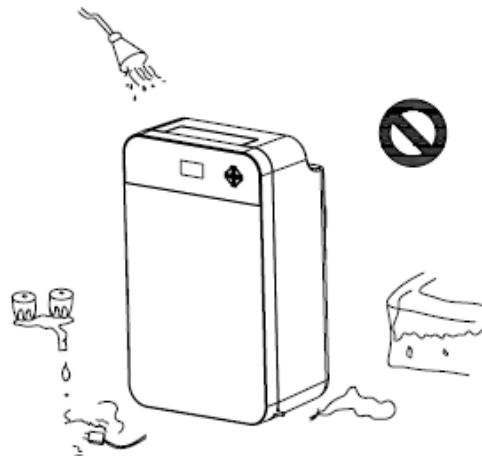
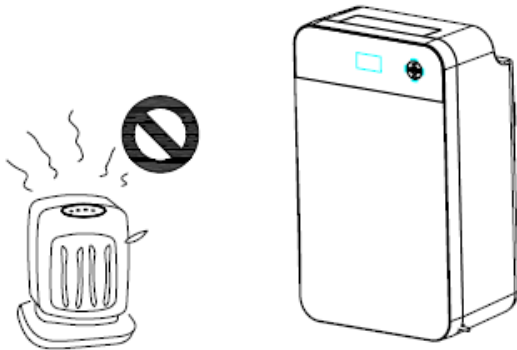

- 5) Do not allow children to operate this unit. Never disassemble the unit, and never try to carry out repairs or adjust the unit yourself.
- 7) Do not use the unit when mounted on a slant. If for any reason the unit falls over, pull out the plug at once.

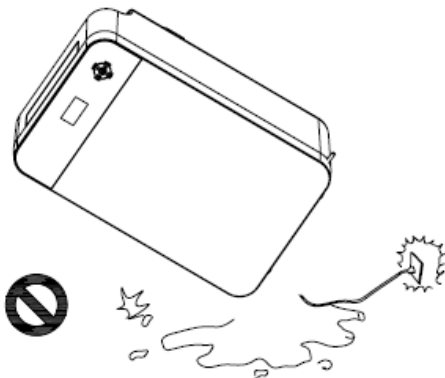

- 4) Do not operate this unit in an explosive or corrosive environment.
- 6) Operate this unit on a horizontal surface to avoid vibration and noise.
- 8) When positioning, ensure there is 30 cm of clear space on each side of the unit.



- 9) Make sure the inlet and outlet ventilation is not blocked at any time.

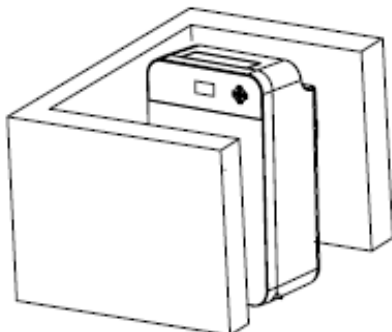

- 10) Never allow water to spray onto the unit. Contact with water may cause malfunction and electric shock.

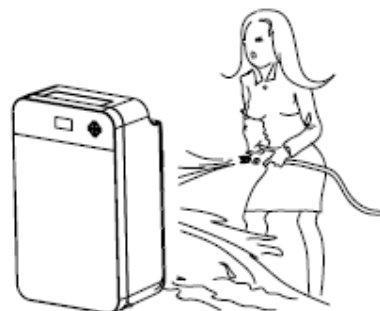

11) Never pull the plug with damp hands.



15) Do not place any foreign objects into any of the openings of the unit.

12) Always switch off at the socket before unplugging to avoid electric shock.

13) When storing the unit, switch it off and unplug it, and ensure the water reservoir is emptied.

14) Do not pull the power wire by force as it will cause damage to wire.

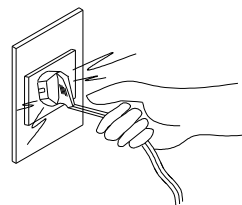

16) Unplug the appliance during cleaning.

## Ambient Environment For Operating

1. Working environment:

Lowest ambient temperature 5° C, 40% RH.

Highest ambient temperature 35° C, 90% RH.

2. Always operate the unit indoors, e.g. living room, bedroom, etc. Avoid using in a wet environment or outdoors.

3. Before turning on the unit, ensure all doors and windows are closed.

4. Ensure that the unit is placed on a stable and flat floor surface. If the floor surface is not even there is a risk that the unit may become unstable and topple over or excessive vibration and noise may occur.

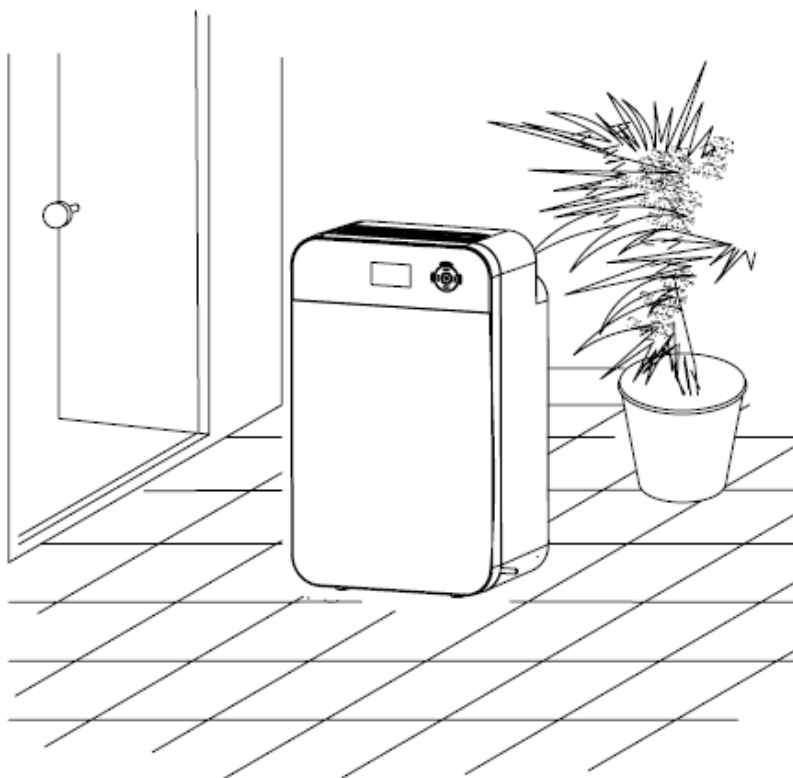

# Component Diagrams

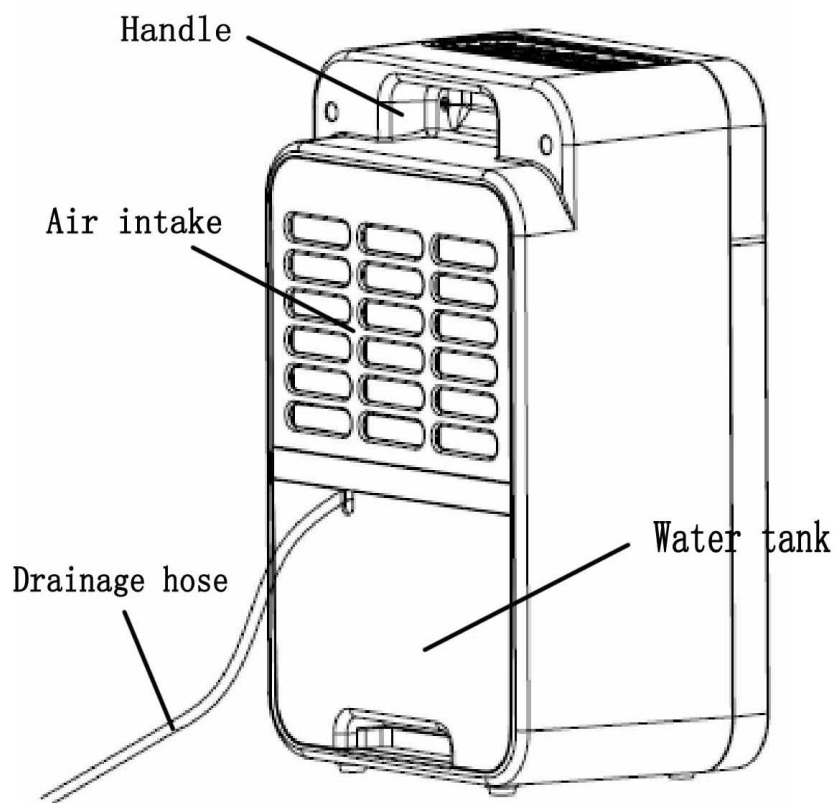
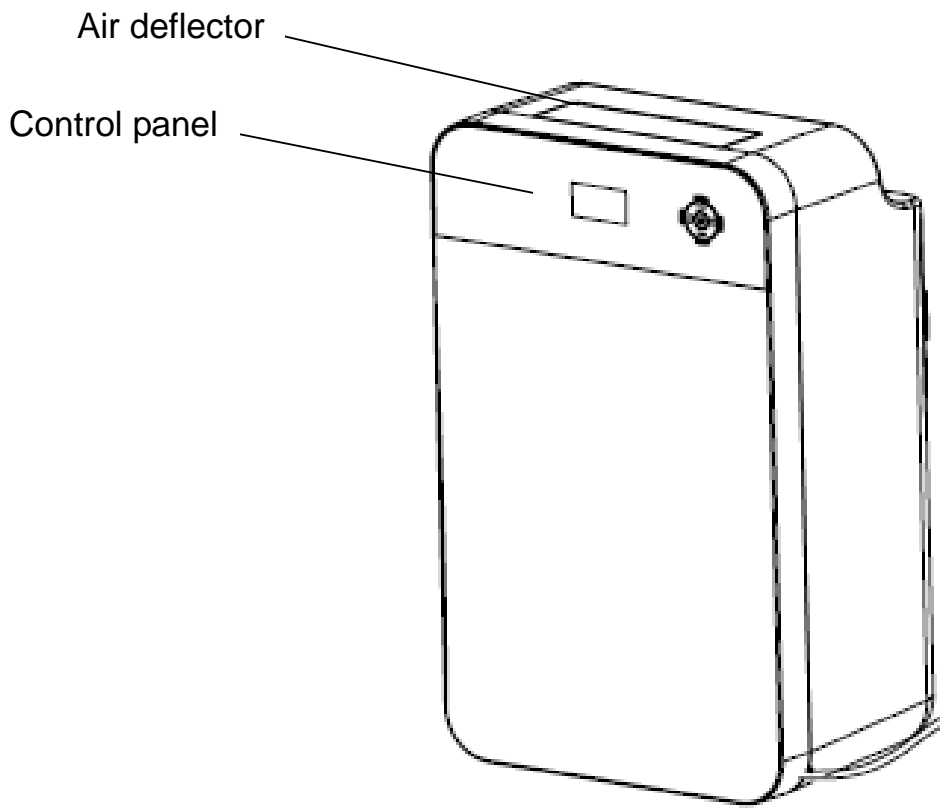

# Operating Introduction

## ● Functions of Control Panel & Key Pads

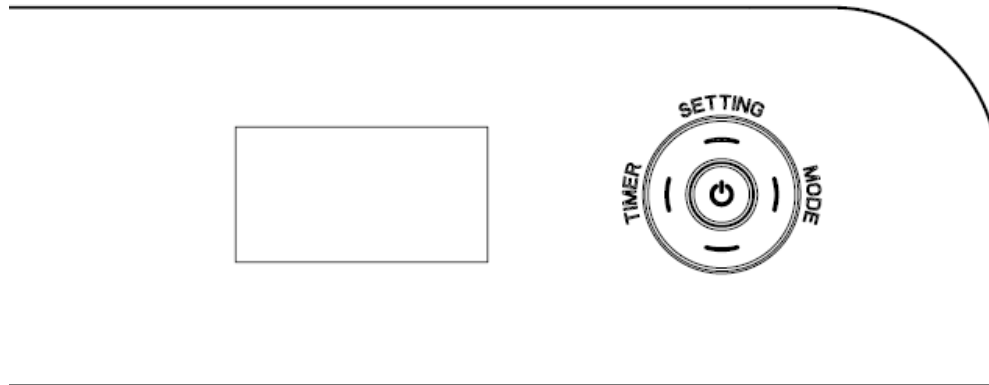

1. POWER: Switch the power button on the unit to start up.
2. Press "mode" to select the desired working mode and the corresponding indicator light will illuminate.
3. Press "Setting" to select the desired running mode and ambient humidity.
4. TIMER: Reserve & Turn Off hour settings.

## ● LCD Monitor

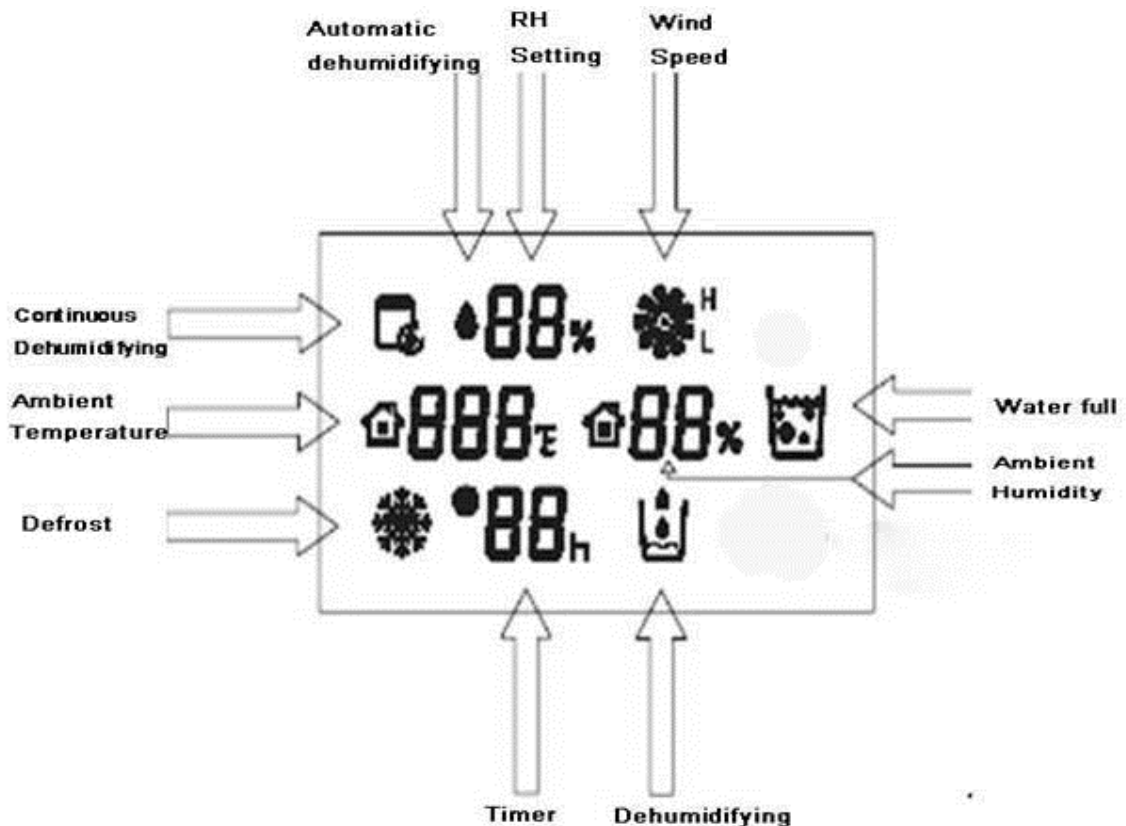

## ● Operation Of Key Pads

1. The unit will beep twice once plugged into the power socket.
2. Press the “ON/OFF” button to turn on the unit. The deflector will startup automatically and at this point, the unit is in the status of constant dehumidifying and high speed running.

- 1) The blue backlight will illuminate and turn off after 15 second.
- 2) The LCD display shows the working mode and status of unit.
- 3) The LCD display shows the ambient humidity and temperature.
- 4) Press the “ON/OFF” button again, the unit will stop working and the deflector close.

### 3. MODE:

Set up continuous & automatic dehumidifying modes and air speed by using the MODE key. Select or change to the desired mode (the indicator light will illuminate accordingly), then press “Setting” to change the running mode and automatic dehumidifying ratio.

- (1) When the automatic dehumidification indicator  illuminates, press “Setting” to make it circulate among 60%RH-65%RH-70%RH-75%RH-80%RH-40%RH-45%RH-50%RH-55%RH-60%RH .....

- 1) When entered into automatic dehumidification, if you press “Setting”, the continuous dehumidifying mode will be cancelled.
- 2) Press “Mode” or three seconds after pressing “Setting”, the desired humidity ratio is set and the indicator light switches off.
- 3) When sensor detected ambient humidity is 1% lower than your setting, compressor shut off and fan works at low speed. If ambient humidity is 5% higher than the setting, the dehumidification is activated again.

- (2) When the wind speed  indicator illuminates, press “Setting” to select your desired fan blower setting of “High speed” level or “Low speed” level.

- 1) It shows ‘L’ when working at “Low speed” level and shows ‘H’ when working at “High speed” level.
- 2) Press “Mode” or three seconds after pressing “Setting”, the wind speed is set.
- 3) When the wind speed is set, dynamic patterns rotate.
- 4) When the sensor detects that the ambient humidity is lower than your desired setting, the fan works at low speed.
- 5) When the sensor detects that the ambient temperature exceeds 32° C, the fan works at the “High speed” level automatically.

- (3) When the continuous dehumidification indicator  illuminates, press “Setting” to make the unit run at the continuous dehumidification mode.

### 4. SETTING:

When the indicator light illuminates according to your desired mode, pressing “Setting” will confirm the running mode or automatic dehumidifying ratio.

5. Press "TIMER":



Press "TIMER" to set the working hours of the unit.



1. Time set for switching on:  
When the appliance is powered off or in standby mode, press Timer 1 to 24H or flexible working time to set up a required operating time. When the unit reaches the requested time, the unit switches on and starts to work automatically.
2. Time set for shutdown:  
When the appliance is powered on, press Timer 1 to 24H or flexible working time to set the unit's running hours. Once the time is set, the remaining hours are shown on the screen until time is up.
3. Please note: The memory function will not work when the timer is set for shutdown.

## ● Automatic Defrosting

A working cycle: When the appliance works in low temperatures, frost may appear on the surface of the evaporator. To ensure the unit performs well in these conditions, an automatic defrost function is fitted to the appliance.

- 1) When a room temperature drops down to 16°C or less, the compressor works for 25 minutes dehumidifying then cuts off. The fan blower then keeps running for 7 minutes to defrost in
- 2) When defrost, Symbol of defrost  displayed on LCD, and the symbol of dehumidification  goes out.
- 3) When defrost, Symbol of defrost displayed on LCD, the compressor is shut off, fan runs at high speed.

## ● Water Tank Full Warning

When the water tank is full, a buzzer will alarm 10 times (for about 5 seconds), and the symbol  that indicates a full tank is displayed on LCD screen. Note all other symbols turn to orange and the appliance cuts out. At this point the water tank must be removed, emptied and reinstalled before the unit can operate again. The interval of dehumidifying lasts about 3 minutes because of the compressor protection.

Remove Water Reservoir as Arrow Direction

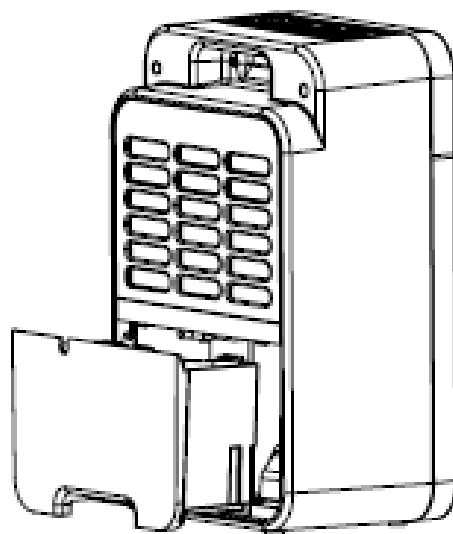
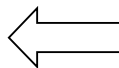



## ● Abnormal Compressor ‘ Warning’

During operation, any malfunction can trip the compressor to fail, resulting in a compressor shut off. It takes 3 minutes to recover from the protection period.



After the water reservoir is removed it takes about 3 minutes to start up the unit again for protection purposes. To avoid this protection period, simply remove the plug from power socket to restart the unit.

## ● Protection Of Extremely Low & High Temperature

1. When the sensor on the air intake detects ambient temperature  $\leq 0^{\circ}\text{C}$  or  $\geq 40^{\circ}\text{C}$ , the appliance will shut off automatically for protection, and the warning beeps will continue with 3 long and 2 short signals.  
When the sensor detects ambient temperatures  $\leq 0^{\circ}\text{C}$ ,  $0^{\circ}\text{C}$  is showed on the LCD display.  
When the sensor detects ambient temperatures  $\geq 40^{\circ}\text{C}$ ,  $40^{\circ}\text{C}$  is showed on the LCD display.
2. When sensor on the evaporator detects its temperature  $\geq 40^{\circ}\text{C}$ , the appliance will shut off automatically for protection, and the symbol for automatic defrost  illuminates.



- 1.If all function keys are not working, you should switch off at the mains to restart the unit.
- 2.After the unit has experienced extremely low & high temperature, the appliance will not keep its memory function when restart.

## ● Failures Of Humidity & Temperature Sensor

1. When an error between the humidity and temperature sensor occurs, the symbol of dehumidification  will flash, and “ $0^{\circ}\text{C}$ ” “ $0\%\text{RH}$ ” is displayed on the LCD display. At this point the appliance adopts the continuous dehumidifying mode.

- 1) If the temperature sensor malfunctions, the appliance will adopt the continuous dehumidification mode and not a controlled humidity setting.
- 2) This malfunction will not influence the dehumidification.

2. When the temperature sensor of the evaporator is an open circuit or short circuit, the symbol of defrost  will flash, and the appliance turns to dehumidifying and defrosting mode: dehumidifying for 20 minutes, then defrosting for 5 minutes.

- 1) If the temperature sensor malfunctions, the keys within the control panel will perform normally.
- 2) If the temperature sensor malfunctions, the appliance will continue to work with lower efficiency.

## ● Memory Function

If the power supply is cut off when the appliance is running, it will memorise its working mode automatically. Once power has been restored, the appliance will restart and continue in this working mode.

- 1) The appliance will not run the memory function for manual & timing shutdown, in this instance the appliance will restart to run in its original state, not recover back to the last set mode.
- 2) If the power supply is shut off into a protection mode, the appliance will not recover back to the last set mode.

## ● Continuous Drainage

Remove water plug and connect with PVC hose with spigot.



PVC hose must be placed on the ground flatly.

Do not tangle the hose.

Do not immerse the hose (outlet) end into another receptacle, as it may cause water flow blockage.

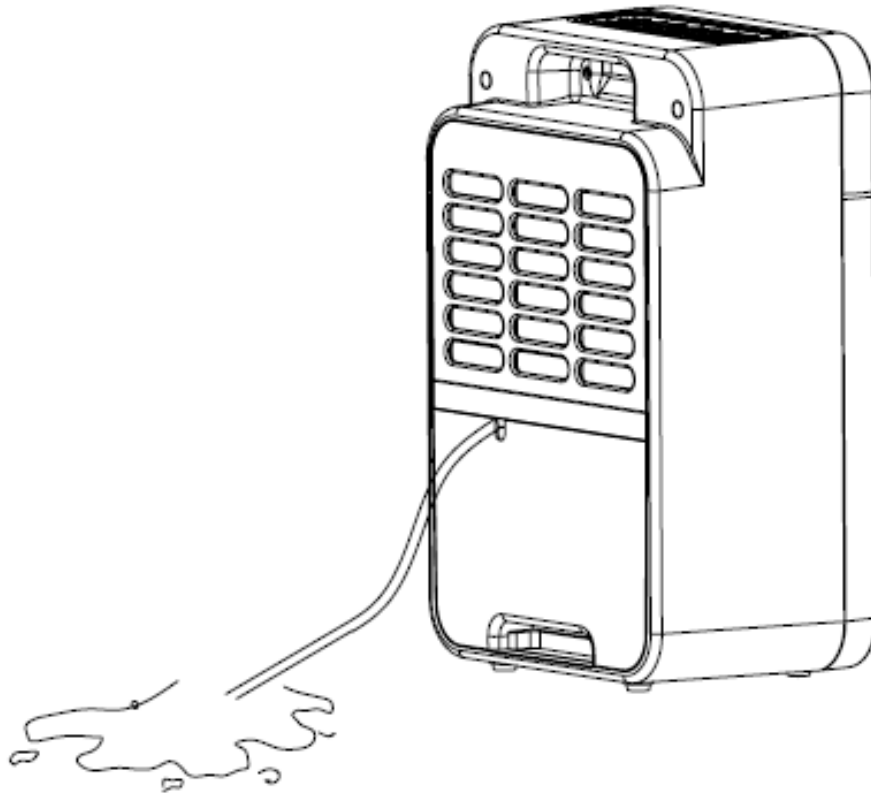

# Maintenance & Cleaning

- ◆ Before any maintenance or cleaning, please switch off and unplug the unit.
- ◆ Do not place in direct sunlight, as the plastic casing may discolour.
- ◆ Take care when removing the water tank.
- ◆ Only use a soft clean cloth to clean this unit. Do not use gasoline, paint thinner or other chemicals to clean the unit.
- ◆ Cleaning mesh filter: Remove the filter in arrow direction (as shown on figures). Use a vacuum cleaner or water to clean, and then put it in ventilated place until it's dry.

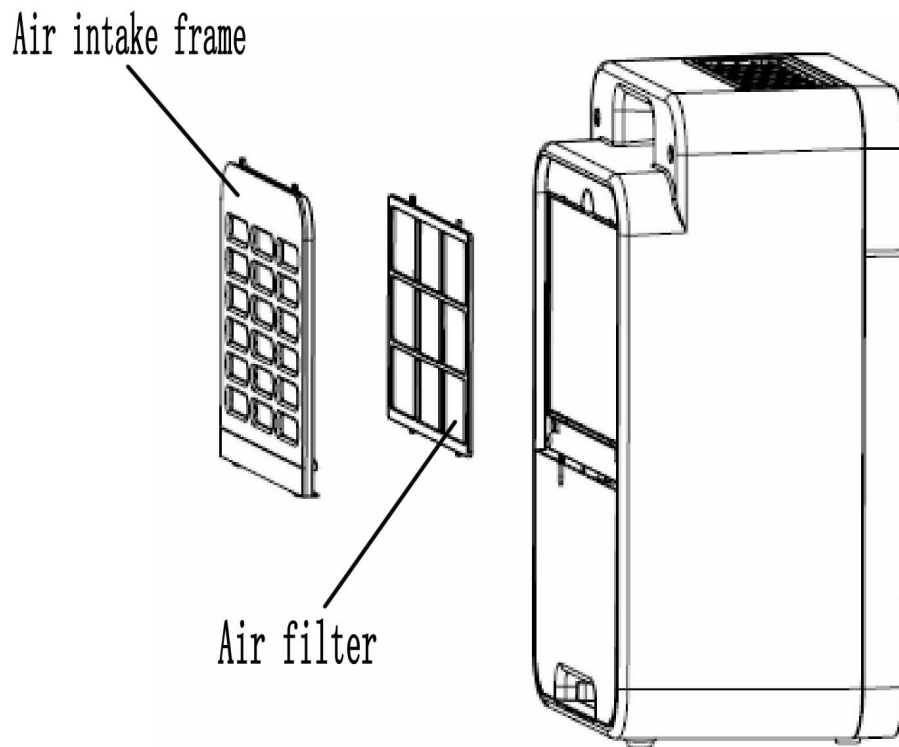

- ◆ Always switch off and unplug before moving this unit.
- ◆ When packing away this unit for a long period of time switch off and unplug the unit, empty the water tank and leave to dry for two days. Then store it in a dry, ventilated place.
- ◆ If you have any problems with your appliance, please approach your dealer.
- ◆ We cannot be held responsible for any damage or injury caused by unauthorized action.
- ◆ If this unit becomes defective, please dispose of it responsibly.

# Specification

Model	WL-YL-2612B
Power Rated	220-240VAC/50Hz
Moisture removal	12 L/D (30°C RH80%)
Dehumidifying Power	255W (30°C RH80%)
Max Power Dissipation	300W (35°C RH90%)
Dehumidifying Air Volume	L:80m <sup>3</sup> /h H:100 m <sup>3</sup> /h
Refrigerant	R134a 120g
Capacity of Water Tank	1.9L
Unit Dimension:	290×201×476mm