

Sea Ray 

Specific
Information
Manual

175 Sport

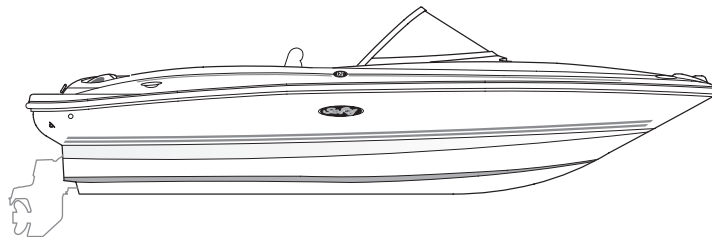

Manual Part Number: MRP 1902268

175 SPORT SPECIFIC INFORMATION MANUAL

TABLE OF CONTENTS

1. Load Capacity.....	1
2. Passenger Locations	1
3. Safety Label Locations	2
4. Basic Boat Dimensions and Clearances	3
5. Helm, Gauge & Switch Layout.....	4
6. Deck Layout.....	5
7. Cleats.....	6
8. Navigation and Anchor Lights.....	6
9. Bilge Layout.....	6
10. Fuel System.....	7
11. Entertainment System	7
12. Canvas.....	7
13. Swim Platform w/ Ladder (Optional)	7
14. Electrical Schematic	7

Information in this publication is based upon the latest product specifications available at printing. Sea Ray® Boats, Inc. reserves the right to make changes at any time, without notice, in the colors, equipment, specifications, materials and prices of all models, or to discontinue models. Should changes in production models be made, Sea Ray® is not obligated to make similar changes or modifications to models sold prior to the date of such changes.

Owner's Manual
175 Sport

Printed in the U.S.A. June 2008

© Sea Ray Boats, Inc. • A Brunswick Company
Sea Ray Boats, Inc. 2600 Sea Ray Blvd., Knoxville, TN 37914
For information call 1-800-SRBOATS or fax 1-314-213-7878
(International 1-314-216-3333)

Internet Address: <http://www.searay.com>

Note: Not all accessories shown in pictures or described herein are standard equipment or even available as options.
Options and features are subject to change without notice.

The following are registered trademarks of the Brunswick Corporation: Sea Ray® & The SR Wave Logo



THIS PAGE INTENTIONALLY LEFT BLANK



175 SPORT OWNERS MANUAL

1. LOAD CAPACITY

Refer to the General Information Manual for a detailed explanation of *Load Capacity*.

DANGER

Never carry more weight or passengers than indicated on the certification plate, regardless of weather or water conditions.

The boat can capsize, swamp or sink.

BUILDER'S PLATE (INTERNATIONAL) (FIG. 1.1)

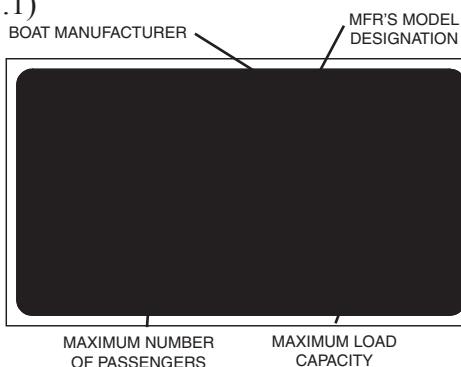

BUILDER'S PLATE (DOMESTIC) (FIG. 1.2)

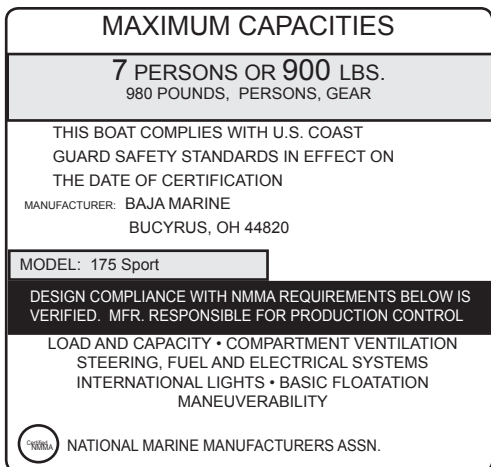

2. PASSENGER LOCATIONS

Refer to the General Information Manual for a detailed explanation of *Passenger Locations*.

WARNING

Boat motion can be erratic.

You can fall overboard or be injured by hitting something in or on the boat.

All persons must be in cockpit area or cabin and be prepared for sudden boat movement.

Use front or bow deck area only during anchoring, mooring or emergencies.

WARNING

Wet decks are slippery.

You can be seriously injured if you slip and fall.

Wear slip resistant footwear secured to your feet and hold on to rails or boat structure.

PASSENGER LOCATIONS (FIG. 1.3)

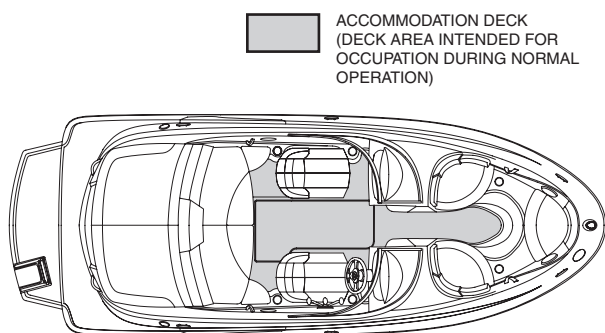

DANGER

Rotating propellers can injure or kill you.

Shut off engine when persons are in water near boat, or on swim platform or ladder.

WARNING

Rear facing transom seats **MUST NOT** be used while engine is running or boat is moving.



175 SPORT OWNERS MANUAL

3. SAFETY LABEL LOCATIONS

SAFETY LABEL LOCATIONS
(FIG. 2.1)

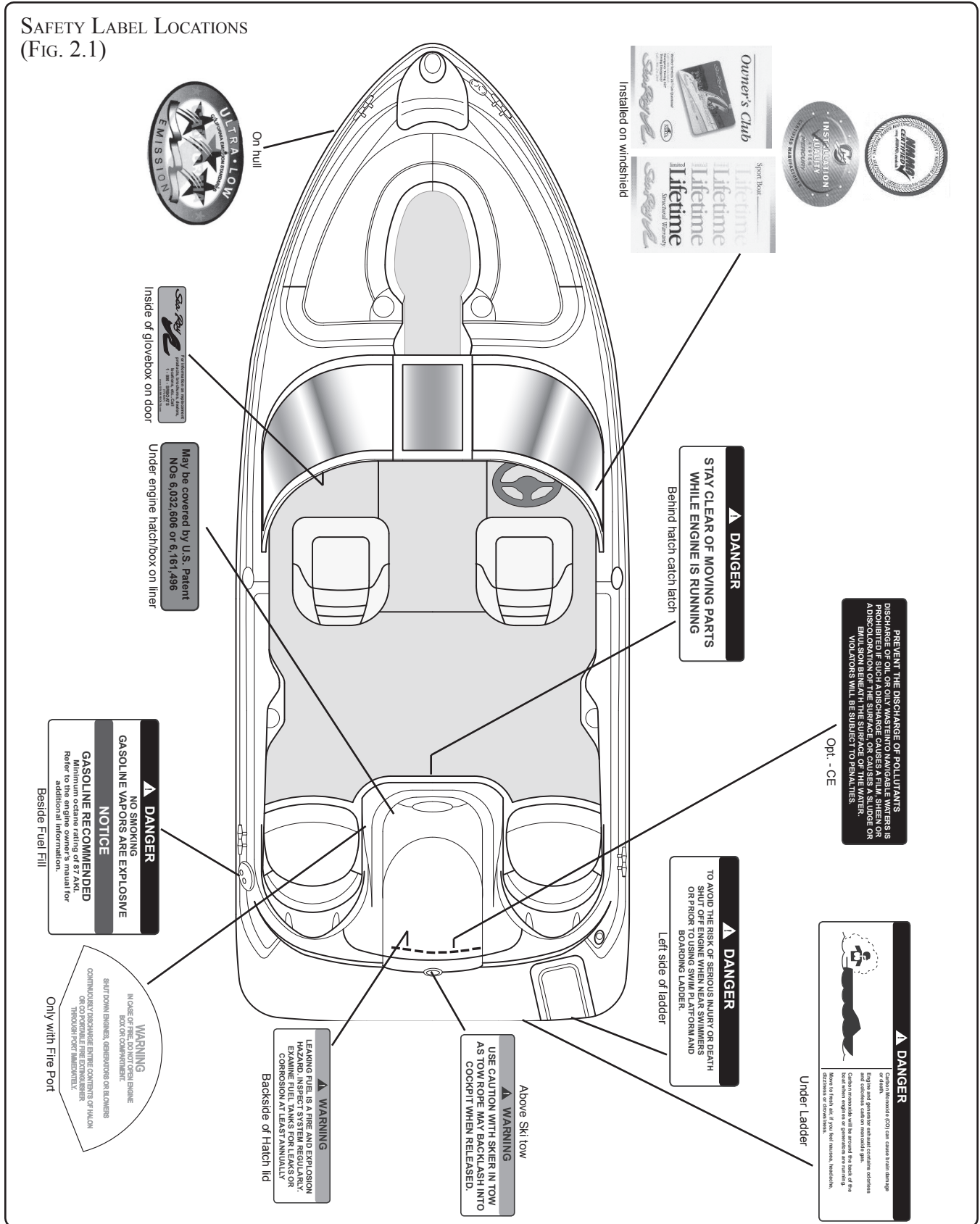

175 SPORT OWNERS MANUAL

4. BASIC BOAT DIMENSIONS AND CLEARANCES

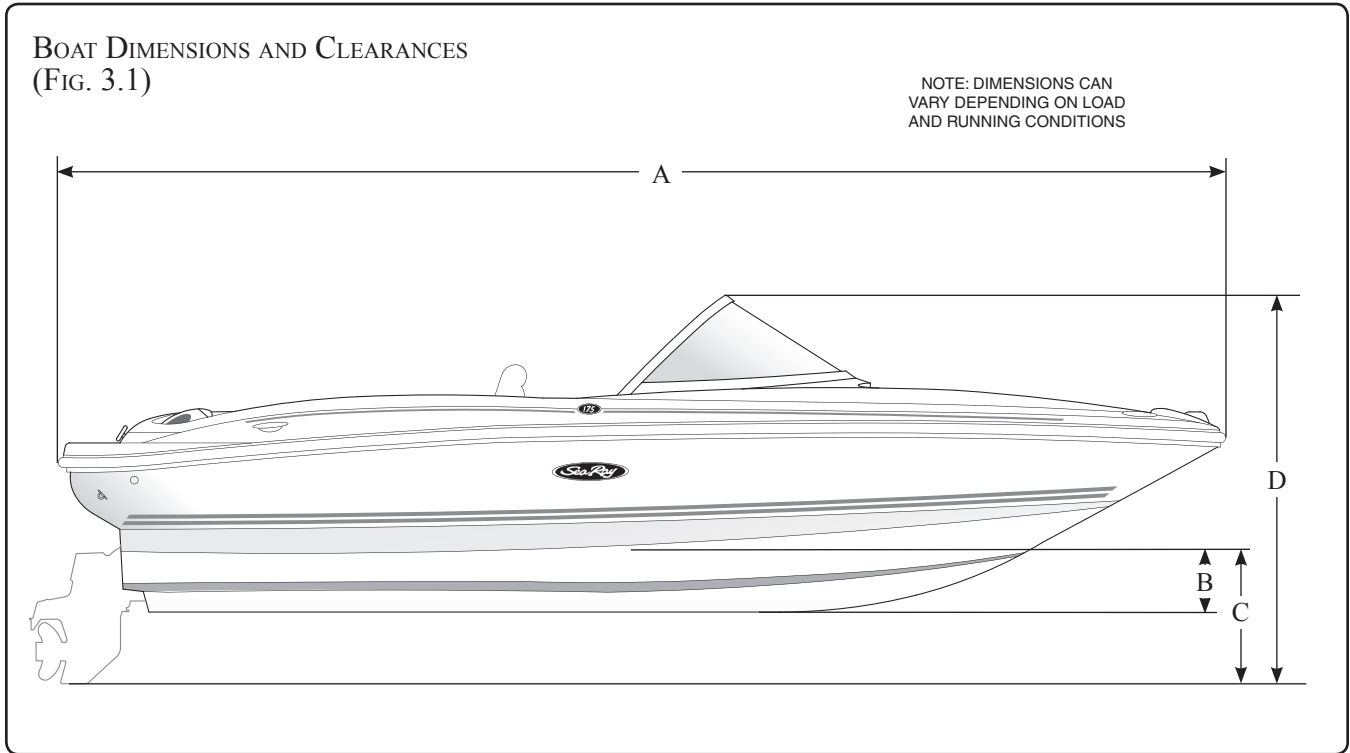

175 SPORT SPECIFICATIONS

- (A) Overall Length.....17'6"– 5.33m
- (B) Draft
with stern drive up in trailering position.....18"–46cm
- (C) Draft
with stern drive down.....35"–89cm
- (D) Clearance from Keel
to Top of Windscreen.....56½"–1.44m
- (E) Beam (width).....7'–2.13m
- Dry Weight.....2,100lbs.–9534kg
- Fuel Capacity.....21gal–79.5 liters

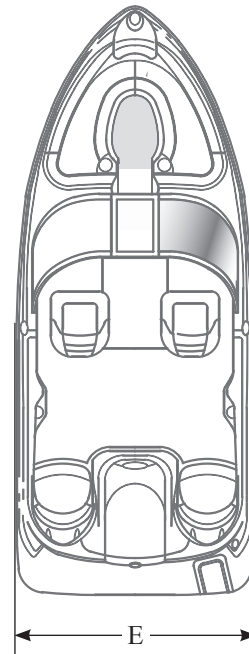

(FIG. 3.2)

Specification measurements are approximate and subject to variance.



175 SPORT OWNERS MANUAL

5. HELM, GAUGE & SWITCH LAYOUT

HELM
(FIG. 4.1)

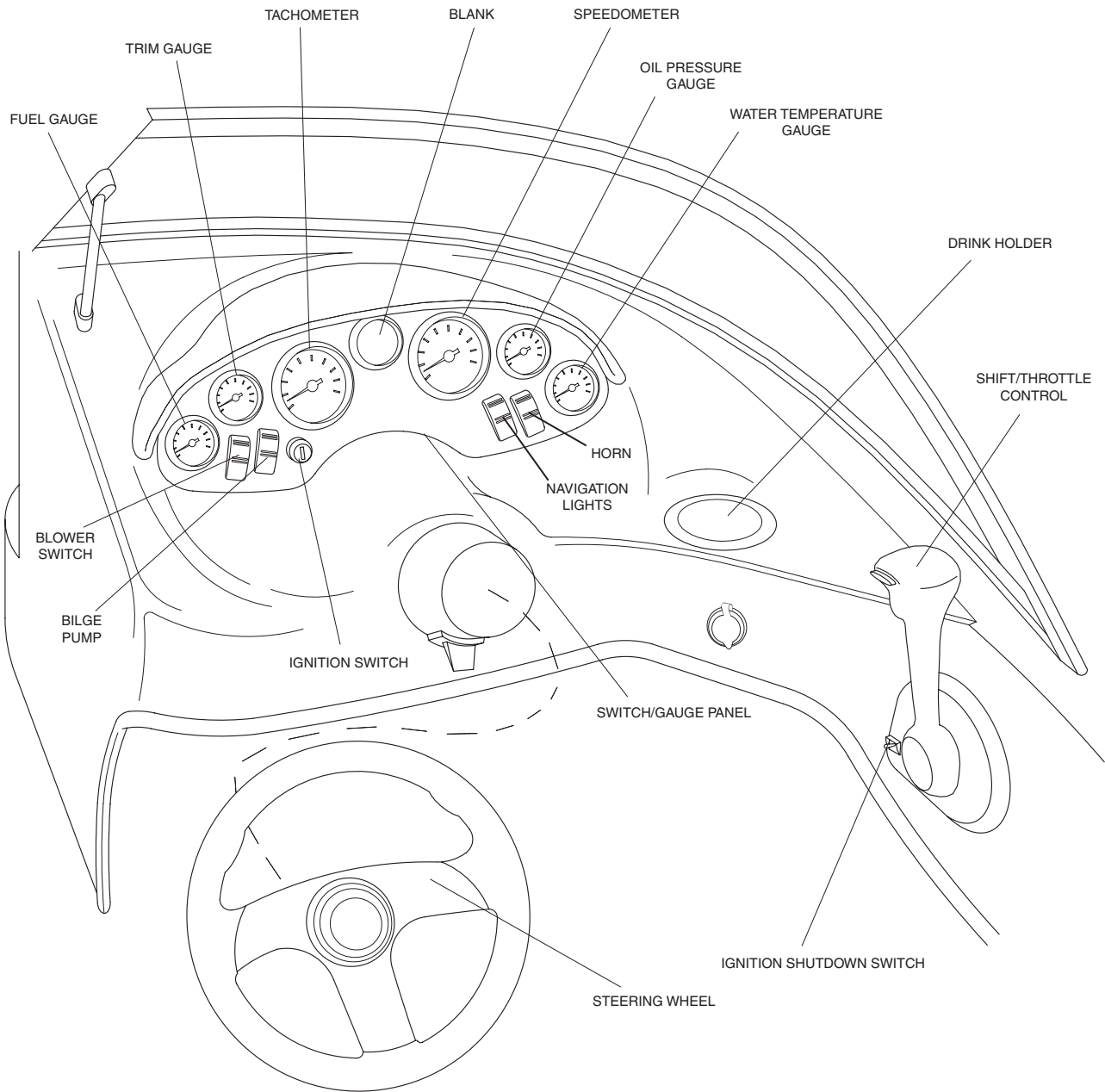

175 SPORT OWNERS MANUAL

6. DECK LAYOUT

GENERAL LAYOUT
(FIG. 5.1)

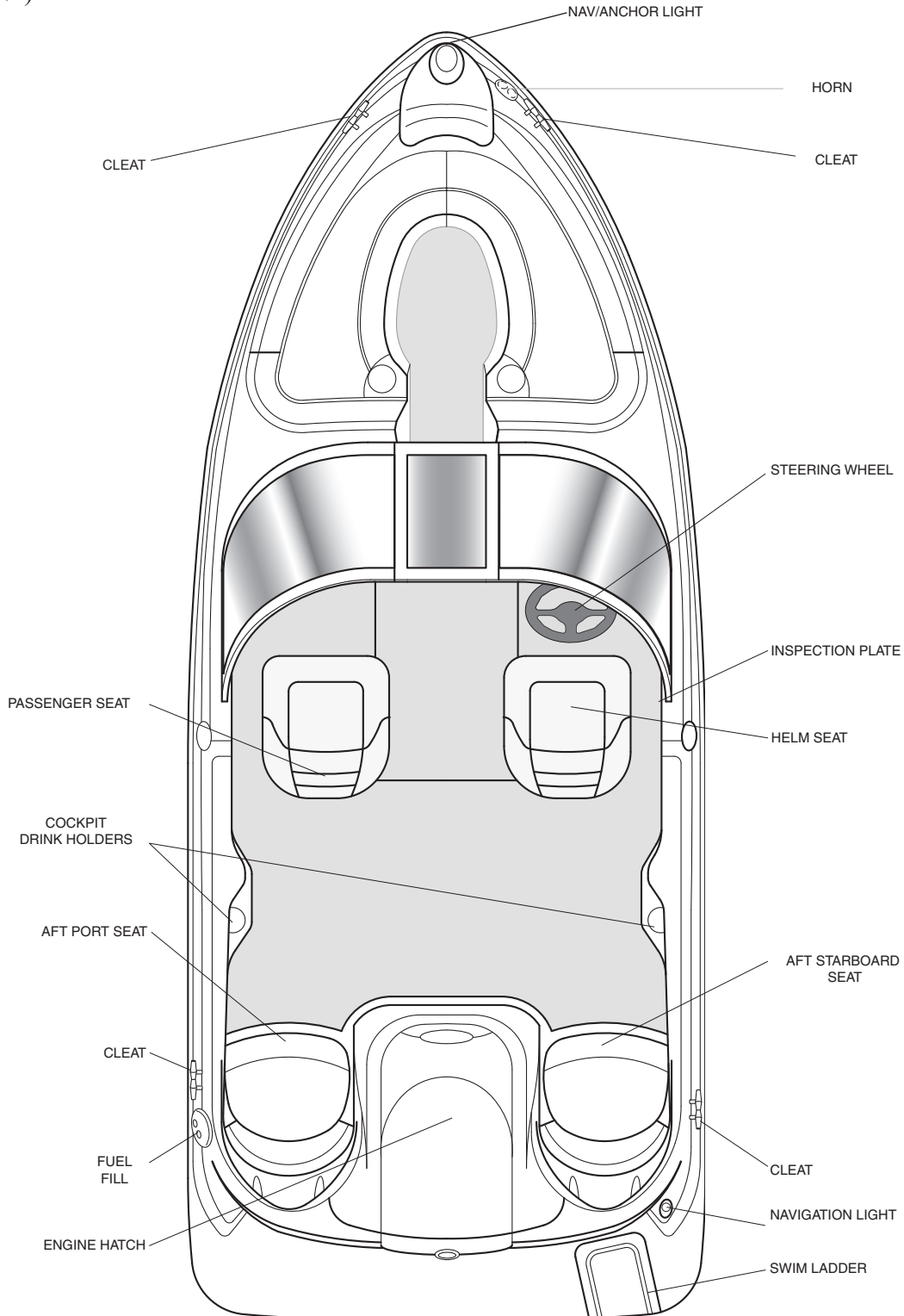

7. CLEATS

Cleats must not be used for lifting the boat; they are intended for docking or mooring use only.

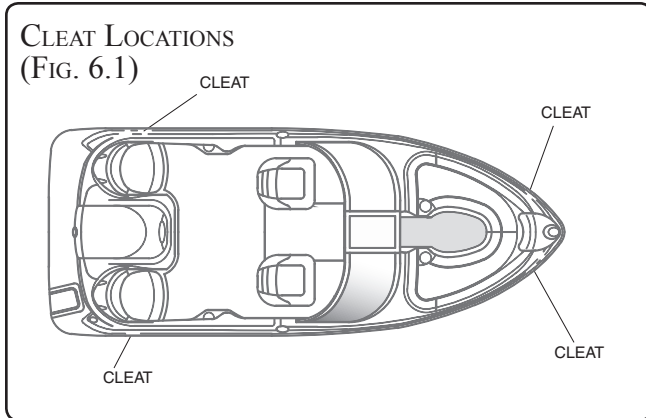

8. NAVIGATION AND ANCHOR LIGHTS

See General Information Manual for a detailed explanation of the anchor lights.

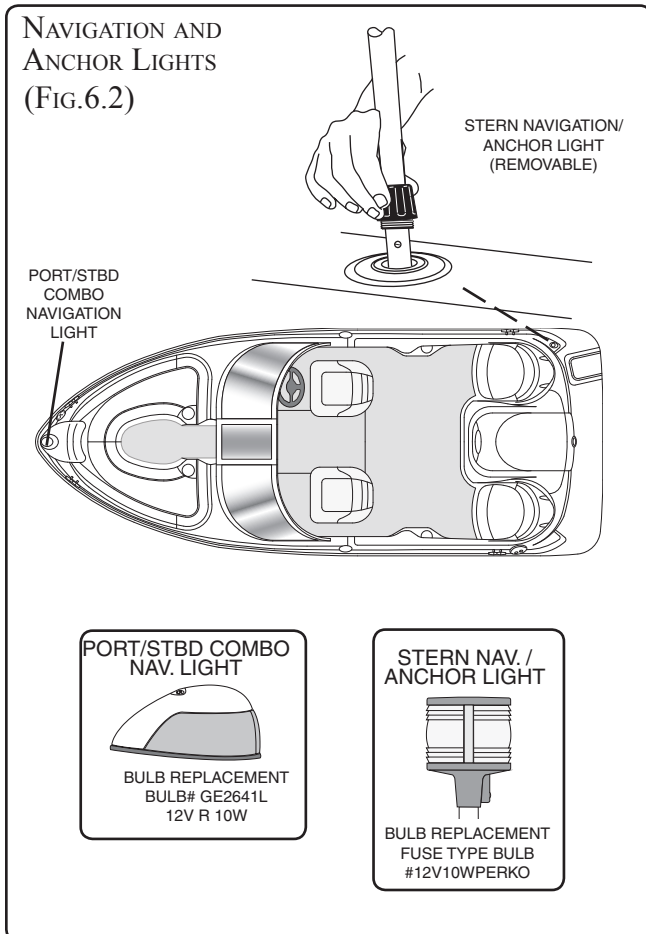

9. BILGE LAYOUT

BILGE LAYOUT
(FIG. 6.3)

- (A) TRANSDUCER (OPT)
- (B) FLOAT SWITCH
- (C) BILGE PUMP
- (D) BATTERY
- (E) FUEL TANK
- (F) BLOWER
- (G) POWER TRIM PUMP

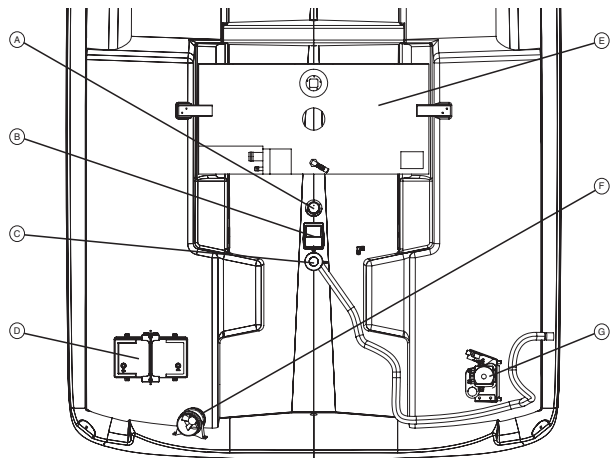

175 SPORT OWNERS MANUAL

10. FUEL SYSTEM

The 175 Sport standard gasoline fuel system consists of a 21 gallon (79.5 liter) fuel tank, fuel tank vent, anti-siphon valve, engine fuel supply line and fuel fill.

11. ENTERTAINMENT SYSTEM

The 12 volt AM/FM radio single CD stereo is located in the port glove box. and includes two (2) water proof speakers.

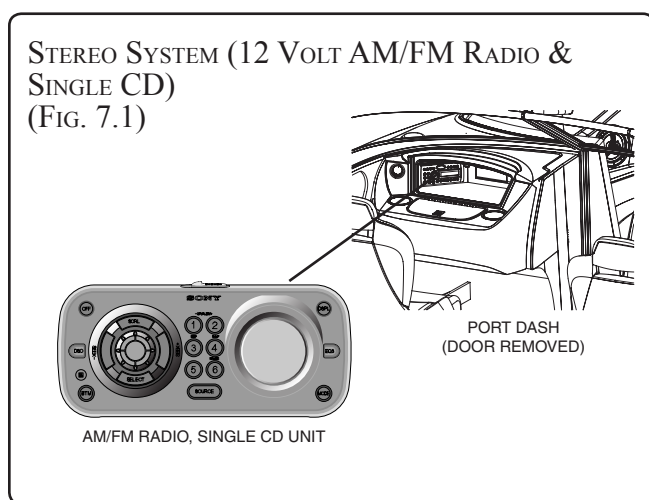

12. CANVAS

The following canvas pieces are available individually as options:

- Bimini Top
- Tonneau Cover
- Trailing Cover

! DANGER

Exhaust fumes from engines contain deadly carbon monoxide gas (CO). Boats enclosed with canvas or with poor ventilation are most likely to collect fumes.

CO sickness symptoms include headache, nausea and dizziness. Do not mistake these symptoms for sea sickness.

Ventilate boat. See Section 1.4, Carbon Monoxide, for more details.

Do not use the rear (aft) curtain while engine is running or boat is moving.

13. SWIM PLATFORM W/ LADDER (OPTIONAL)

With this option, entering the boat from the water is more convenient, but there are safety rules that must be followed.

1. Never sit on the swim platform when boat is moving.
2. Before using or extending the ladder, make sure engine is off and prop is stopped.
3. It may be difficult to extend the ladder while in the water so it important to leave the ladder down if swimmers are in the water.
4. Always make sure ladder is secure before starting engine.

! DANGER

MAKE SURE ENGINE IS OFF AND PROPELLER IS STOPPED BEFORE USING BOARDING LADDER

14. ELECTRICAL SCHEMATICS

This owner's manual contains electrical schematics and wiring harness illustrations for your boat. These electrical schematics were generated by electrical CAD designers at the engineering division for technical reference and service technicians. Sea Ray® does not recommend that you attempt to work on the boat's electrical system yourself. Instead, we recommend that you take your boat to your authorized Sea Ray® dealer for service. Sea Ray® reserves the right to change or update the electrical system on any model at any time without notice to the consumer and is NOT obligated to make any updates to units built prior to changes.

175 SPORT OWNERS MANUAL

DC WIRING INFORMATION
(Fig. 8.1)

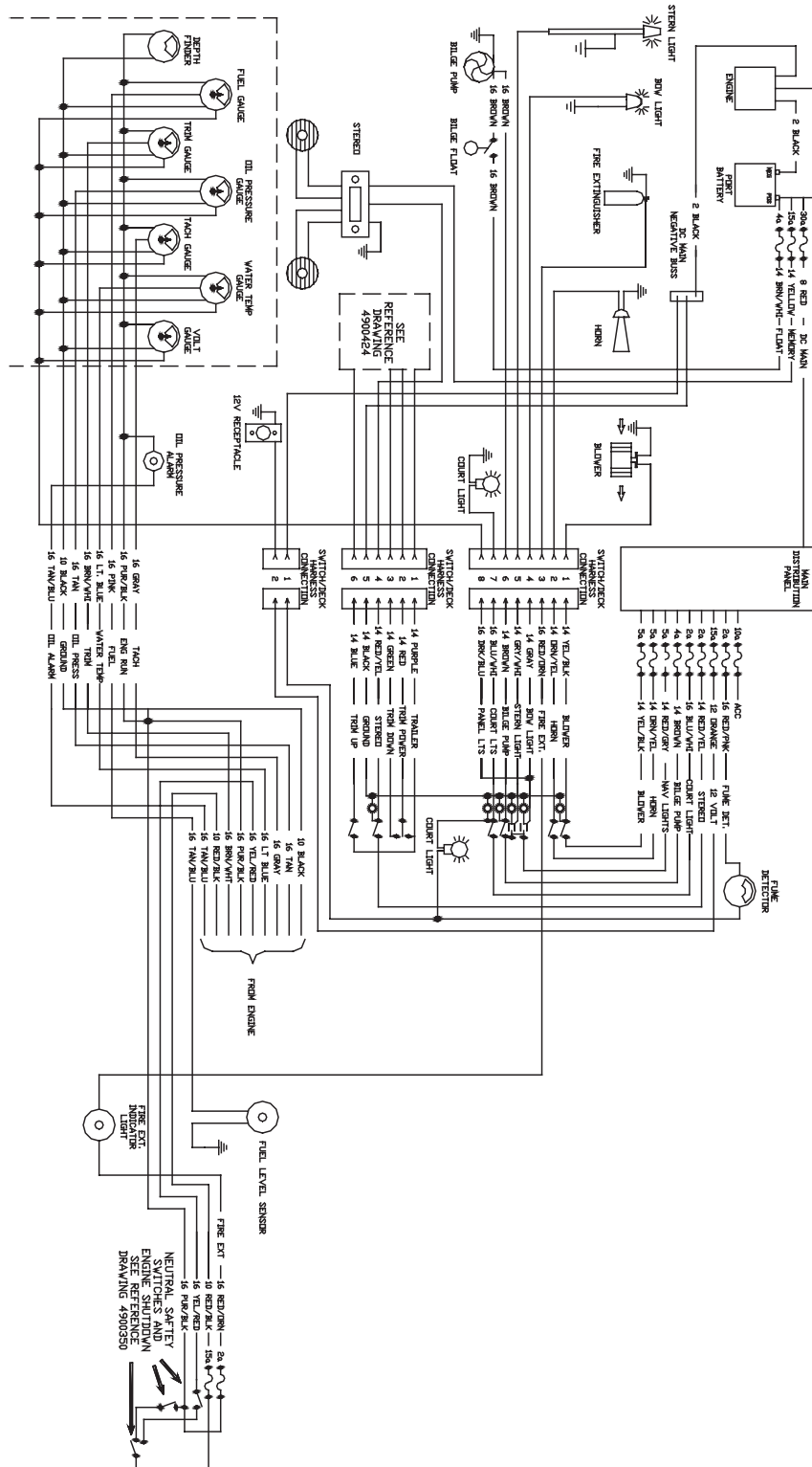

Warning:
DO NOT attempt to work on the electrical system of this boat without professional assistance.



175 SPORT OWNERS MANUAL

SWITCH PANEL WIRING INFORMATION
(FIG. 9.1)

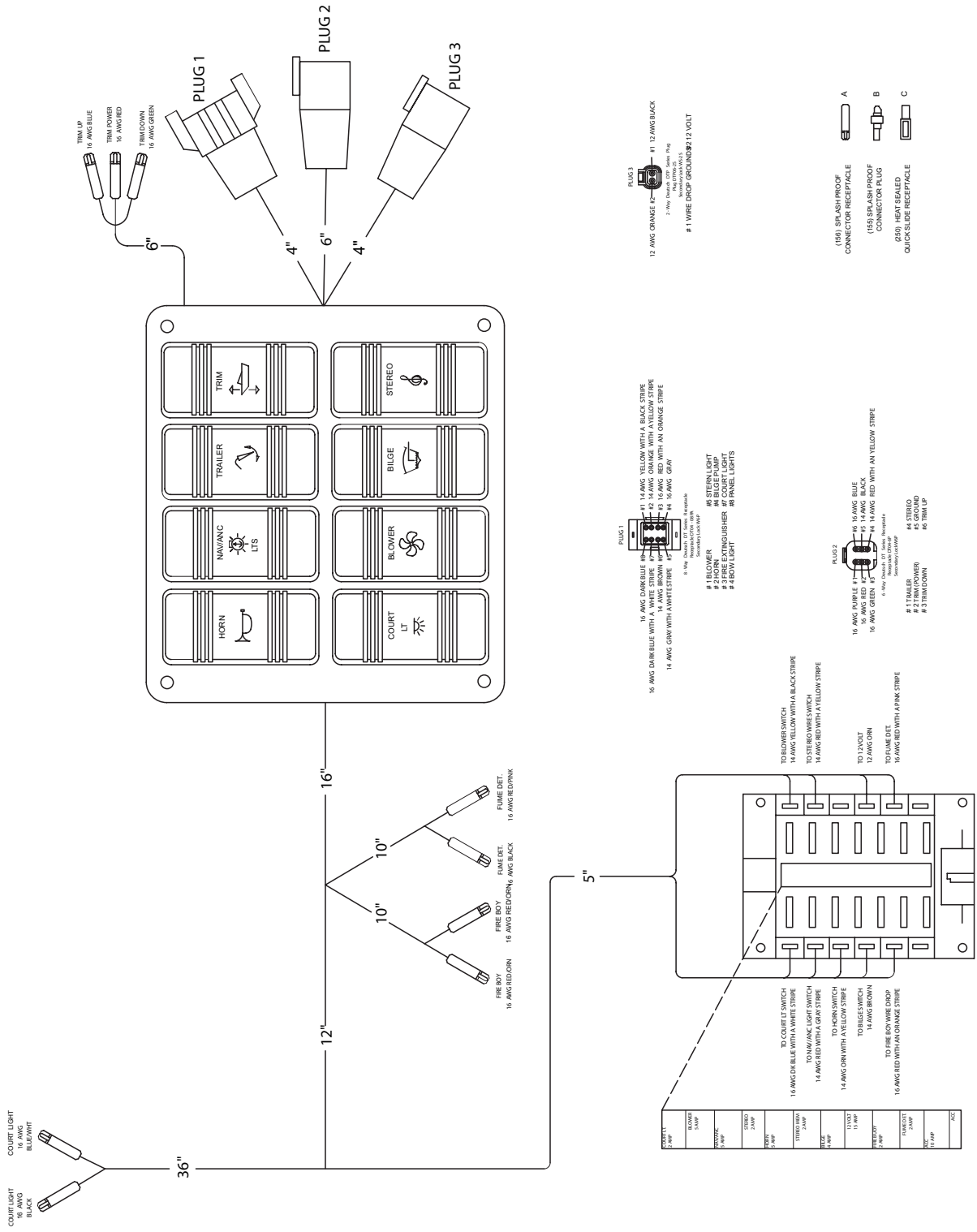

Warning:
DO NOT attempt to work on the electrical system of this boat without professional assistance.



175 SPORT OWNERS MANUAL

THIS PAGE INTENTIONALLY LEFT BLANK



INDEX

A

Anchor Lights..... 6

B

Basic Boat Dimensions and Clearances 3
Bilge Layout..... 6

C

Canvas 7

D

Deck Layout..... 5

E

Electrical Schematics 7
Entertainment System 7

F

Fuel System..... 7

G

Gauge Layout..... 4

H

Helm Layout 4

L

Load Capacity..... 1

N

Navigation Lights..... 6

P

Passenger Locations 1

S

Safety Label Locations 2
Swim Platform 7
Switch Layout 4



THIS PAGE INTENTIONALLY LEFT BLANK

Sea Ray 
