

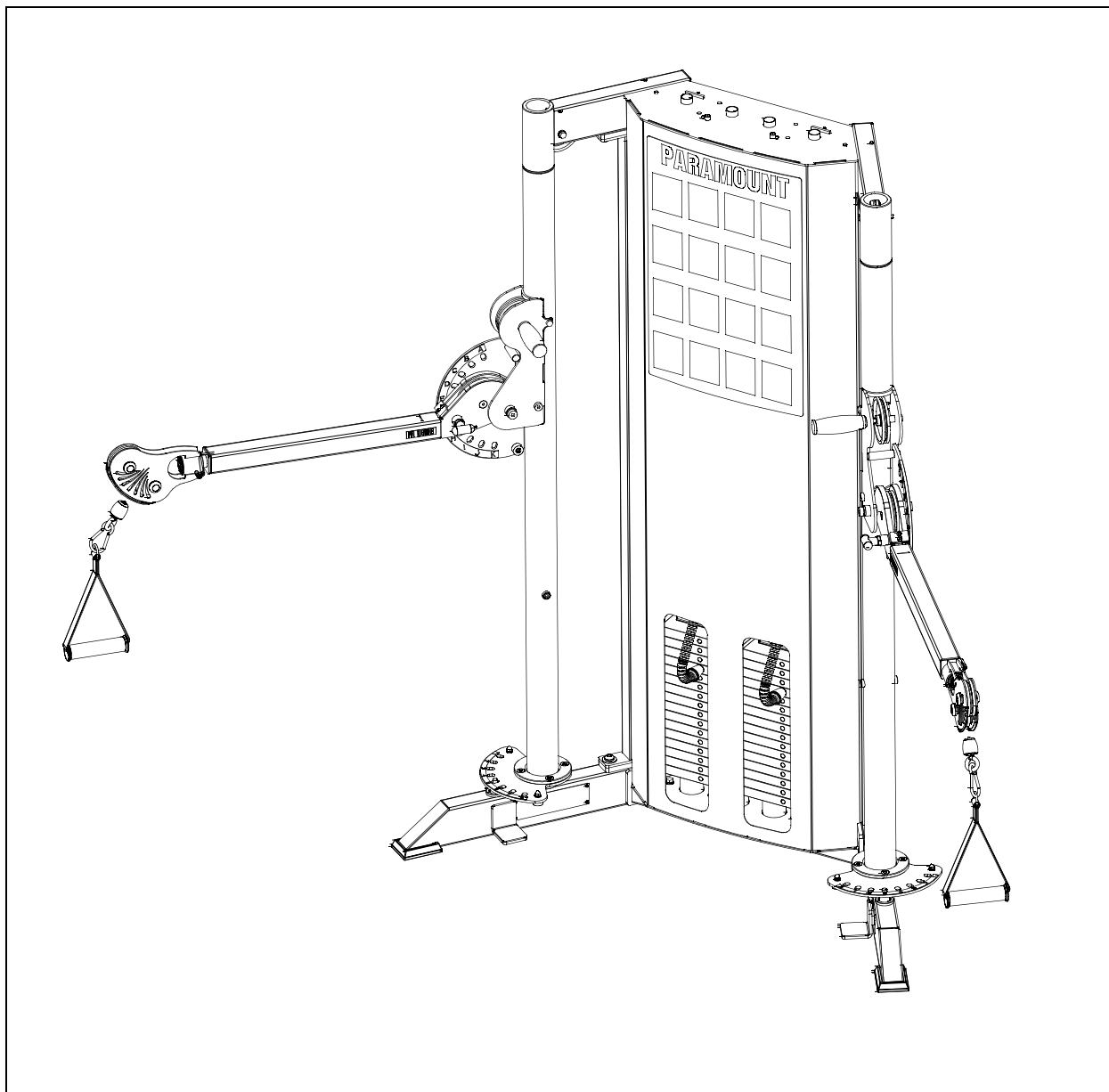

ASSEMBLY MANUAL

PFT-200 FUNCTIONAL TRAINER





SAFETY REQUIREMENTS

1. **Review and understand** all of the warning labels affixed to the machines and the facility safety sign. Replace any warning label at the first sign of wear. Labels and the Facility Safety Sign may be obtained from Paramount free of charge.
2. **Be certain that machine operation is understood** before machine is used. Refer to the instruction label provided with the machine. Instruct users **NOT** to invent exercises or modify the machine to perform exercises.
3. **Keep children away** from this equipment. Supervise use by teenagers.
4. **DO NOT** high-pin or double-pin the weight stack. **DO NOT** allow the machine to be used if the top plate or weight stack is pinned in a raised position. Use an assistant and carefully return the machine to the proper position with the cap plate resting on the top weight. Inspect the cable to ensure that it is seated in all of the pulleys.
5. **Use ONLY Paramount weight selector pins.** Other manufacturer's pins may work free of the weight stack causing possible injury. **Be certain the pins are completely inserted and that the coiled lanyards clear the weight stack enclosure prior to use.**
6. **Cables:** Inspect the entire cable regularly and the end fittings daily. Pay close attention to the area going over the pulleys and to the end connections. **Replace all cables at first signs of wear. Use only Paramount supplied replacement cables.** Ensure that the dimension from under the bolt head to the top surface of the selector bar is no greater than 1-3/8 inches (see installation). Ensure that the cable tension bolt & nut are tight.
7. **Instruct Users NOT** to attach both cables to single bars or handles. Use one handle or exercise bar for each weight stack.
8. **Adjustment Pins:** check the function of the position selector pins on the adjustable arms. Make sure that the selector pin inserts completely into each position without binding.
9. **Instruct Users NOT** to make arm position adjustments during exercise or when pulling on the cable end.
10. **Nuts, Bolts, and Fasteners:** Check tightness weekly. If any hardware has become loose, retighten and/or use Loctite™ Threadlocker 242.
11. **Frames and Lifting Arms:** Inspect weekly for integrity and function. Replace any component at first signs of wear.
12. **DO NOT** attempt to free any jammed assemblies by yourself as this may result in injury.
13. **DO NOT** use incremental weights or adder weights with this machine.
14. **Instruct Users** not to wear loose or dangling clothes or have headphone wires hanging when using this equipment.
15. **Recommend** that users receive a medical exam before commencing an exercise program. User should stop exercising if they feel faint or dizzy.
16. **Regularly Check** the function of your machine by verifying the following:
 - Cables and end fittings are intact and tensioned properly.
 - All adjustments are possible and carried out with ease.
 - The proper selector pin is in the weight stack.
 - The exercise is performed smoothly, free of noise and/or binding.
 - The guide rods are properly lubricated.
17. **Follow the installation guidelines** provided with the products.
18. **Retain these instructions** for future reference.

If you have any questions, do not hesitate to contact your Paramount Dealer of Paramount Fitness Corp. at (800) 721-2121 or www.paramountfitness.com.

Refer to Maintenance Schedule label located on the machine for maintenance intervals.



MAINTENANCE REQUIREMENTS

- **Frames:** Wipe all machines down with a damp cloth and **dry completely** each day. This includes painted and chrome parts and upholstered pads.
- **Painted/chrome parts:** Use Simple Green or similar cleaner for light dirt and grime. Use TurtleWax® Polishing Compound or a good car polish to remove heavier dirt and grease as well as for polishing. **DO NOT** use solvents, lacquer thinner, acetone, floor cleaners or finger nail polish remover. For scuffs and marks that are not removed by the above methods use a soft scrub cleanser.
- **Weight stack enclosures (shrouds):** Wipe down with a damp cloth as needed.
- **Exercise instruction labels:** Clean with soap and water as needed.
- **Guide rods:** Wipe all dirt and dust off the guide rods before applying a light application of Tri-Flow™ or other silicone spray lubricant, spraying the Tri-Flow™ on a rag and then wiping the guide rods with the rag. **DO NOT** use light oil base lubricants such as WD-40. *Caution: Tri-Flow™ will stain carpet and clothing.*
- **Bronze bushings:** Check monthly for signs of wear and replace as needed. Lubricate monthly with Tri-Flow™.

We recommend that you purchase the Paramount Performance Kit (P/N KIT-01) to maintain your Paramount products. This will insure that the proper maintenance materials required will be used. Please refer to the General Maintenance Manual (p/n AM-GMM) for other important safety and maintenance information.

ASSEMBLY NOTES

- Read the assembly instructions completely before beginning to assemble the machine. This will help you to become familiar with the machine and prevent mistakes requiring unnecessary disassembly and reassembly.
- Hardware placement is indicated with a balloon. Refer to the hardware page for corresponding size and configuration.
- **Be sure all hardware is tight before using the machine.**

TOOLS REQUIRED:









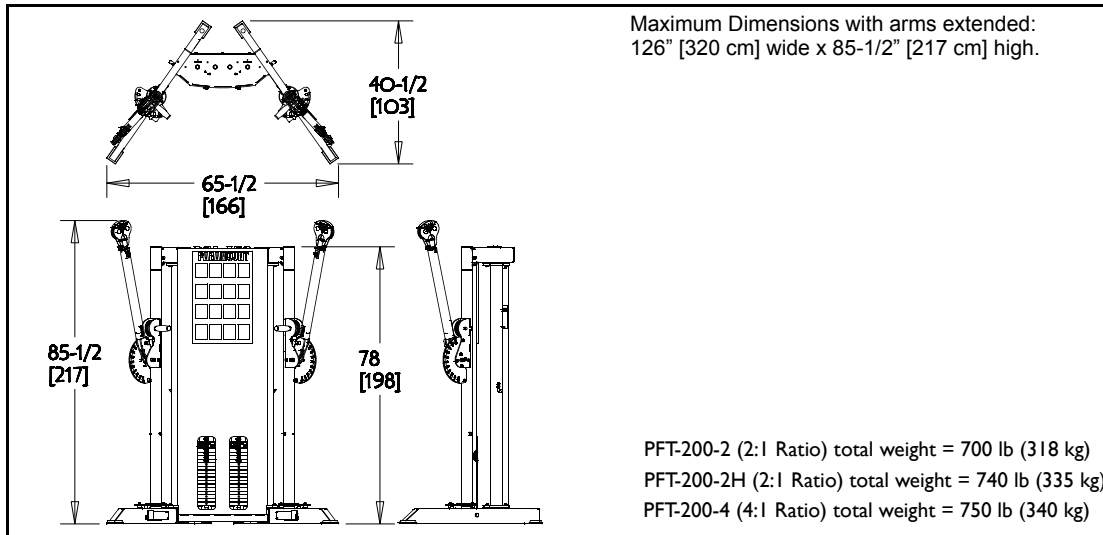

PFT-200 ASSEMBLY INSTRUCTIONS

1. The PFT-200 requires a floor area for the base frame of 65-1/2" x 40-1/2" [166 cm x 103 cm] with a minimum ceiling height of 78" [198 cm]. To accommodate the full range of the adjustable arms, a minimum area of 126" [320 cm] wide x 85-1/2" [217 cm] high is required.

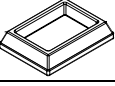
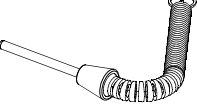

PFT-200 HARDWARE BAG

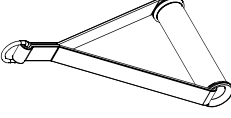
ITEM	DESCRIPTION		QTY	PART #
1	Accessory Hook		2	PFT2003008
2	Button Head Screw, 1/4-20 X 3/4 Lg		4	C 675B
3	1/4" Lock Washer		4	C 747
4	1/4" Flat Washer		4	C 752
5	Molded Paramount Foot		4	B 751
6	Selector Pin, Magnetic		2	B 470
7	Snap Hook		2	B1005
8	Handle, Nylon Strap		2	B1110
9	Hole Plug, 1" Diameter, Black		2	B1216



2. ASSEMBLING THE CATCH HOOKS & MOLDED FEET

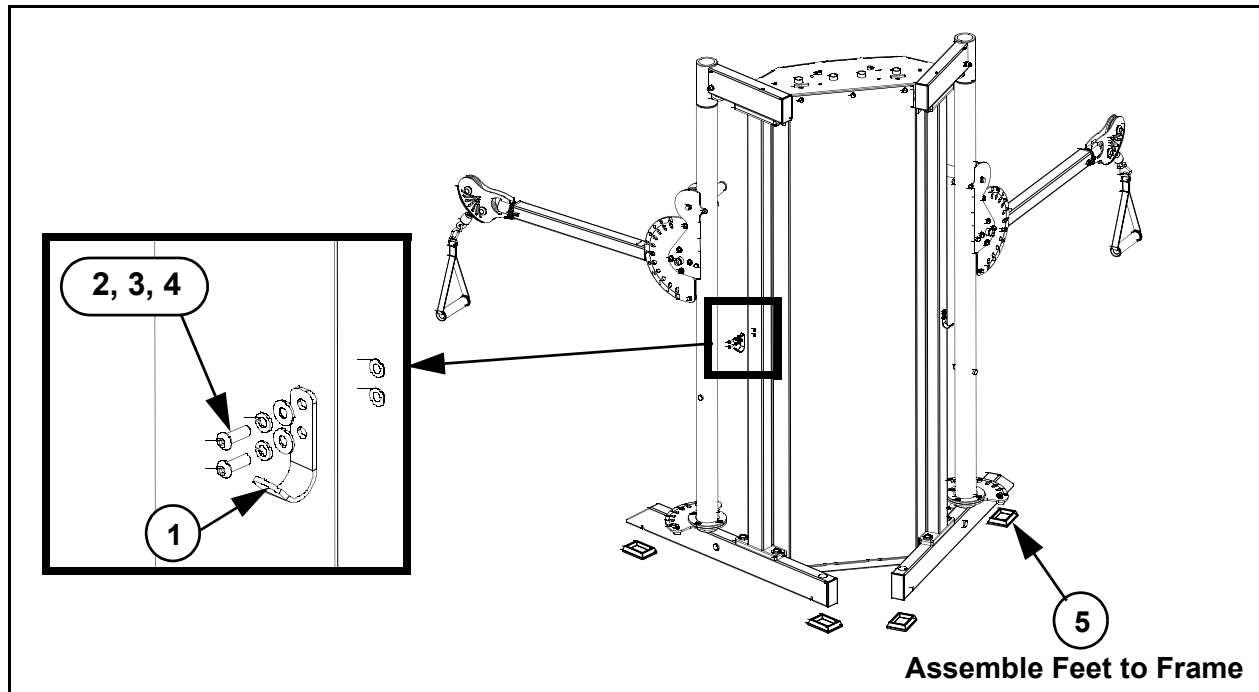

3. WEIGHT PLATE INSTALLATION

Depending upon the purchased configuration, your PFT-200 will require either (7) or (8) boxes of weights (P/N B1602).

PFT-200-2 2:1 Ratio	PFT-200-2H 2:1 Ratio	PFT-200-4 4:1 Ratio	P/N: B1602 Box comprised of (4) EACH 10lb MACHINED WEIGHT PLATES
<p>(14) x 10lb plates per stack, (2) stacks per machine. Requires (7) Boxes of B1602</p>	OR <p>(16) x 10lb plates per stack, (2) stacks per machine. Requires (8) Boxes of B1602</p>	OR <p>(16) x 10lb plates per stack, (2) stacks per machine. Requires (8) Boxes of B1602</p>	

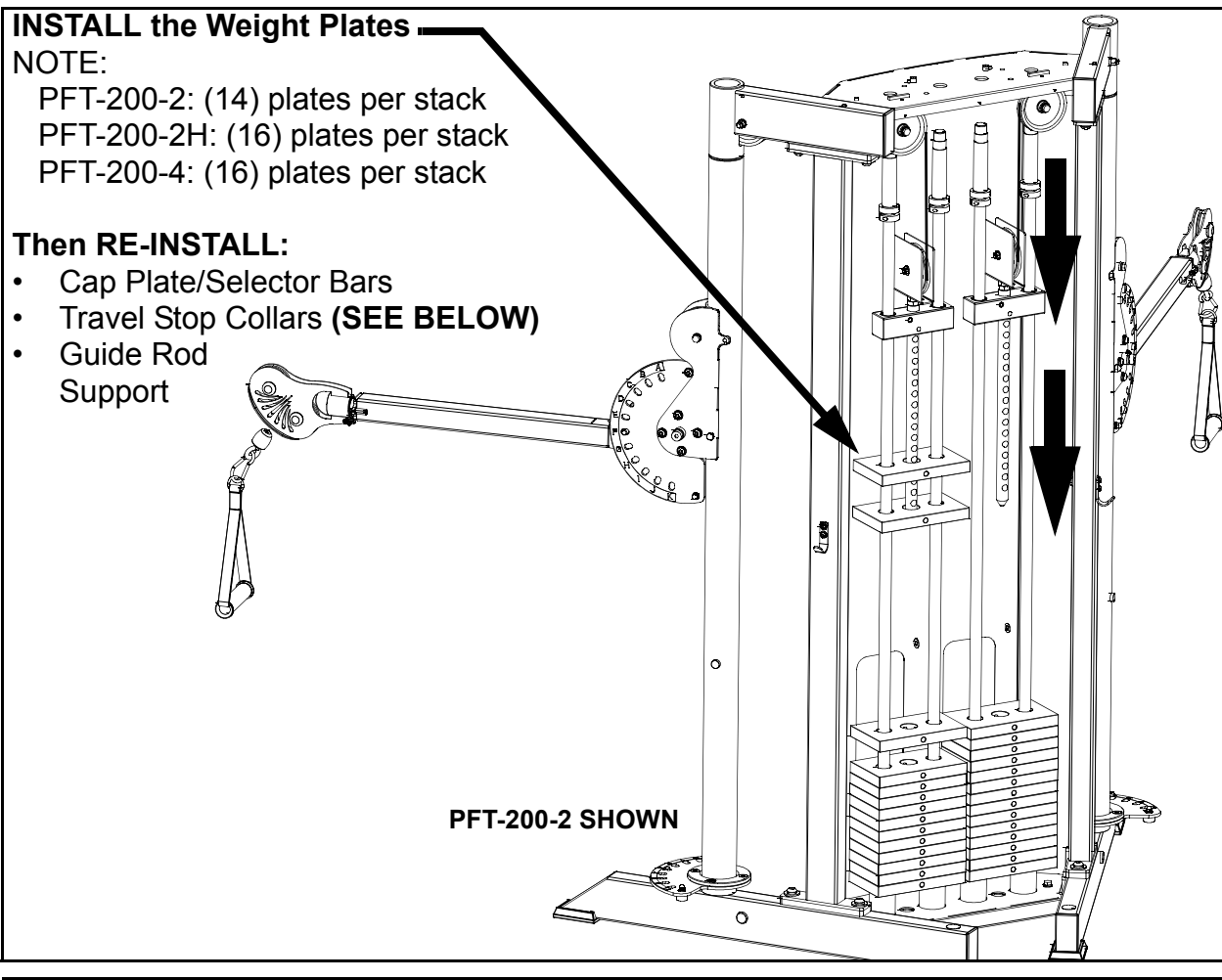
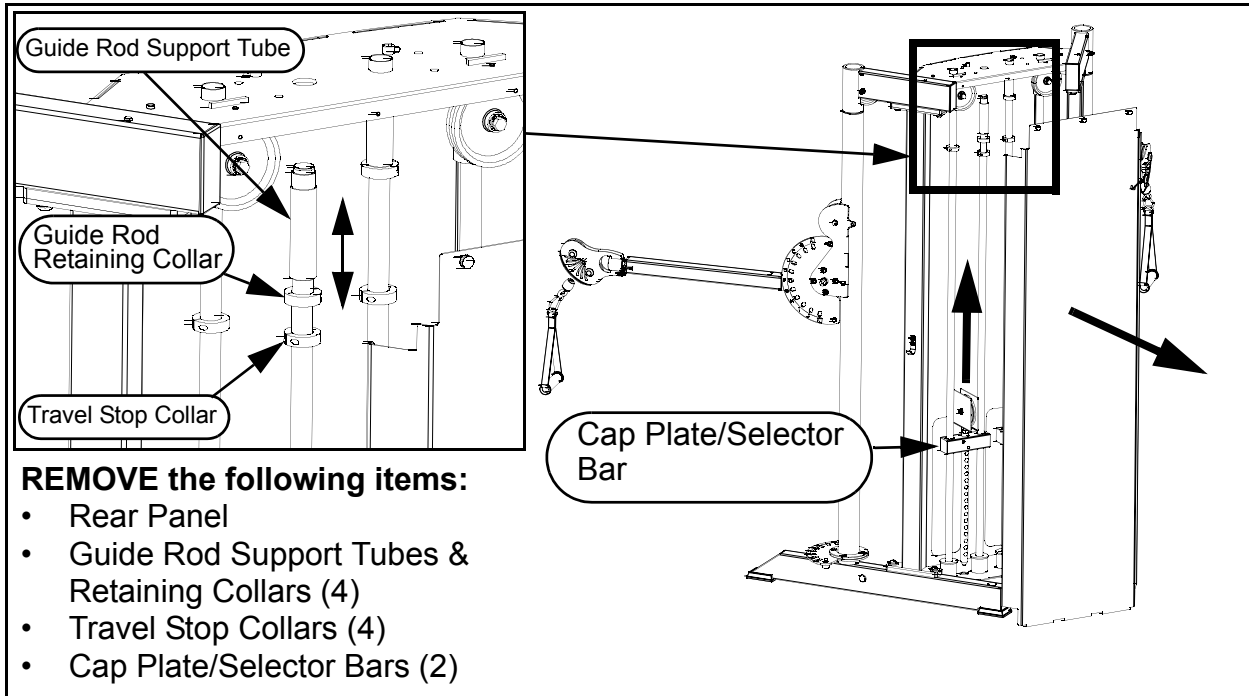

PARAMOUNT

To correctly assemble the guide rod support tubes:

- A) Press guide rod down firmly.
- B) Press guide rod retaining collar & support tube upward firmly and maintain contact with the top plate.
- C) Tighten the guide rod retaining collar to hold the tube in place.
- D) Set Travel Stop Collar Spacing as shown.

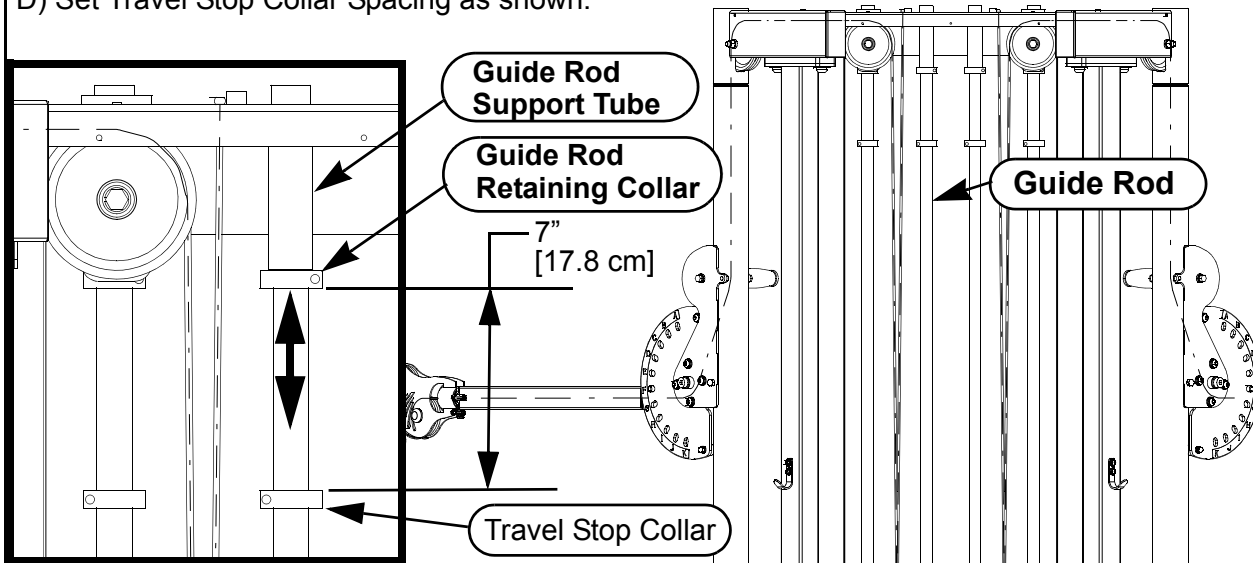

4. ASSEMBLE THE SELECTOR PINS

NOTE: These (2) views show the front of machine with the front cover removed for clarity. You DO NOT need to remove the front cover to assemble the selector pin. Assemble the selector pin lanyard to the pulley housing as shown.

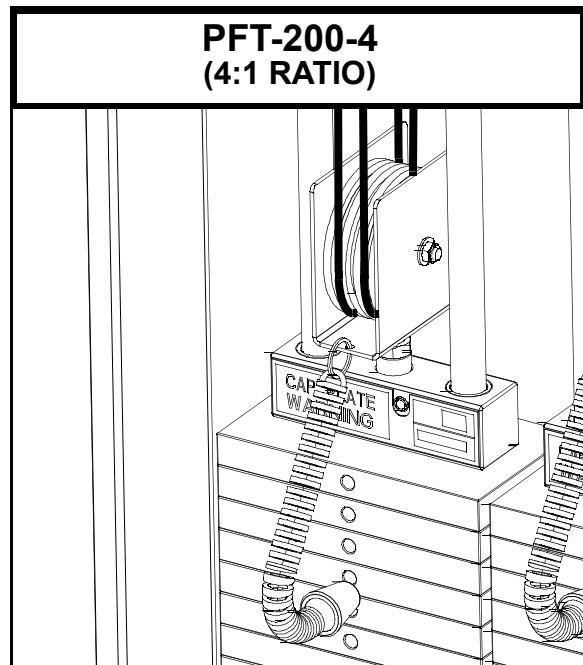
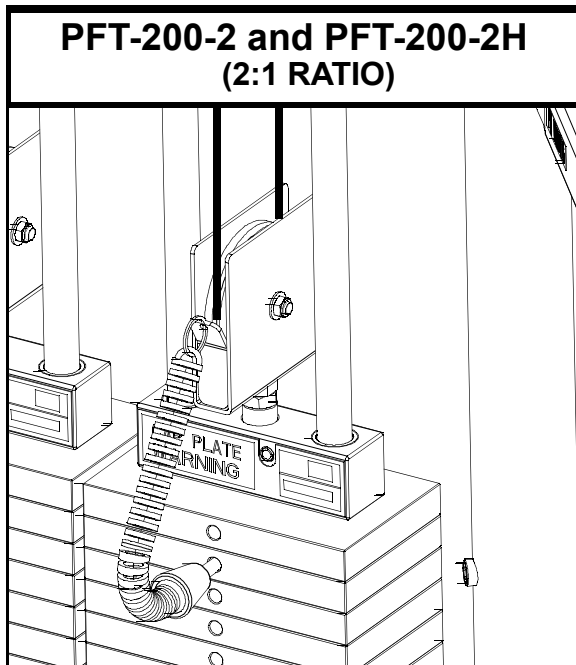

PARAMOUNT

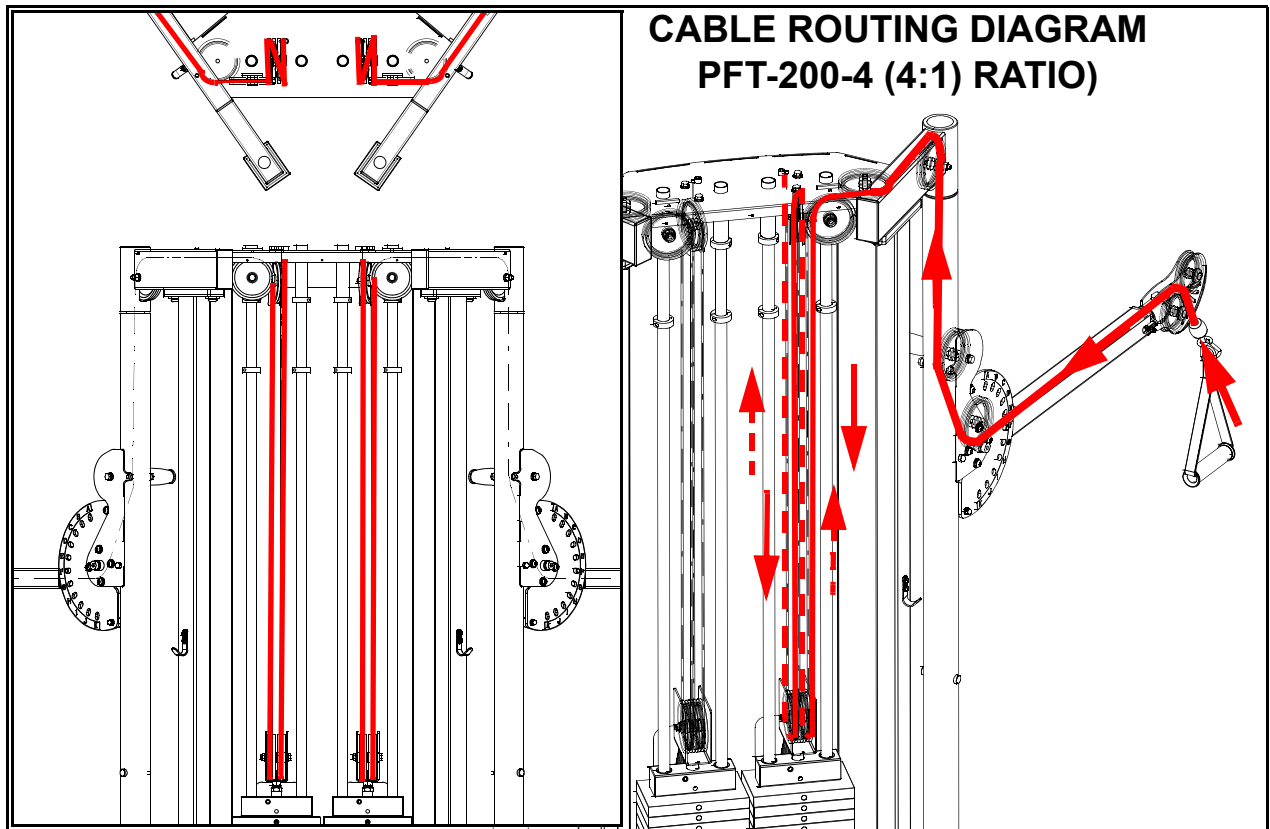
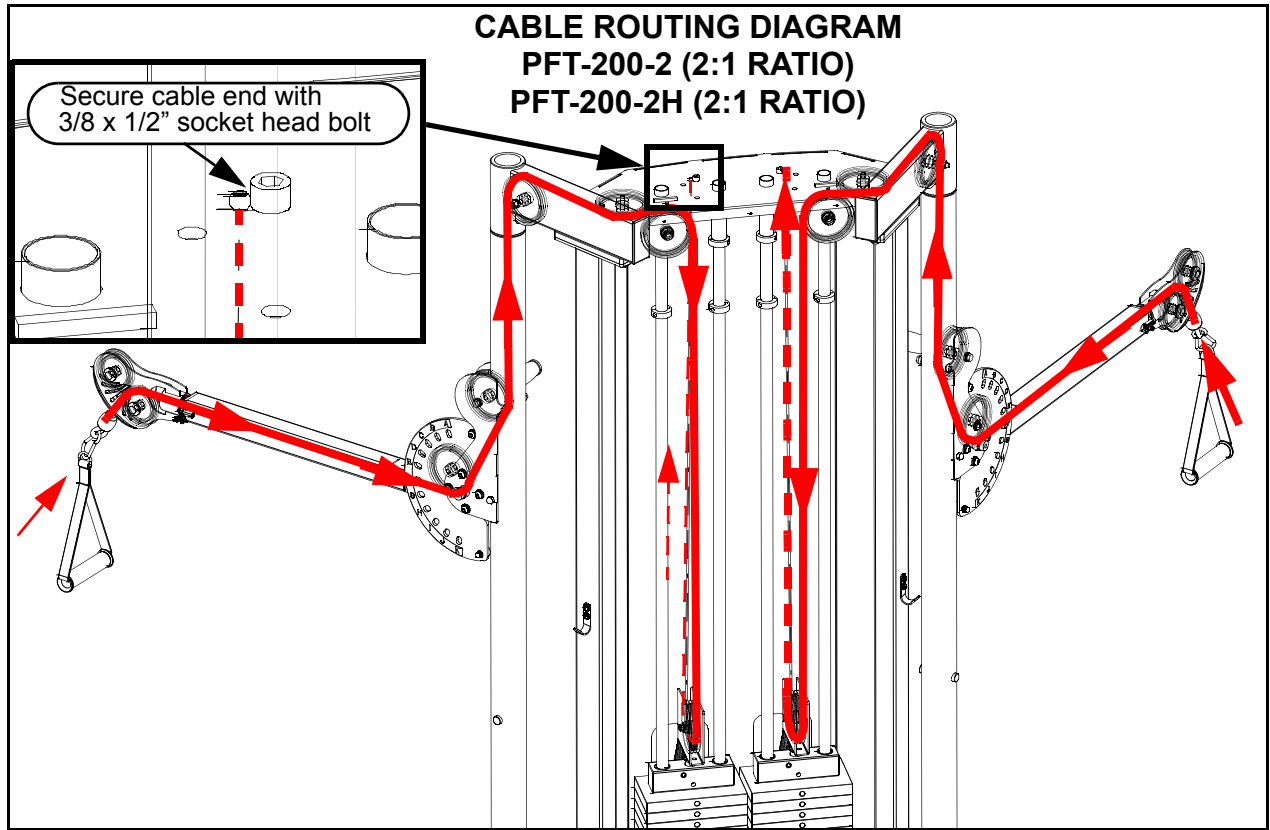



WEIGHT STACK LABEL INSTALLATION

Shipped with your machine are (2) sets of labels for the weight stack numbers. Follow the instructions printed on the label. The PFT-200 configurations are listed below along with the corresponding label set part numbers.

MACHINE	PFT-200-2 (2:1 RATIO)	PFT-200-2H (2:1 RATIO)	PFT-200-4 (4:1 RATIO)
Weight Stack	150 lb. (14 x 10 lb.)	170 lb. (16 x 10 lb.)	170 lb. (16 x 10 lb.)
Weight Stack Resistance	75 lb.	85 lb.	42.5 lb.
Label Part No.	B2173*	B2173	B2176

*** NOTE: Label B2173 has 16 weight labels ranging from 10 - 85 lbs. For the PFT-200-2, discard the last two labels (80 and 85 lbs).**

To install weight stack labels:

1. Verify that the weights are installed properly.
2. Wipe front surface of the weights with rubbing alcohol and allow to dry completely.
3. Remove the backing from the labels. Align the top edge of the label with the top edge of the weights and the side of the label with the outside edge of the pin hole in the weights.
4. Verify that the label strip is straight and then remove the liner. As the liner comes off the labels, press and rub each label into place.
5. The adhesive requires 48 hours to cure so **DO NOT** attempt to “test” the integrity of the labels after they have been installed.

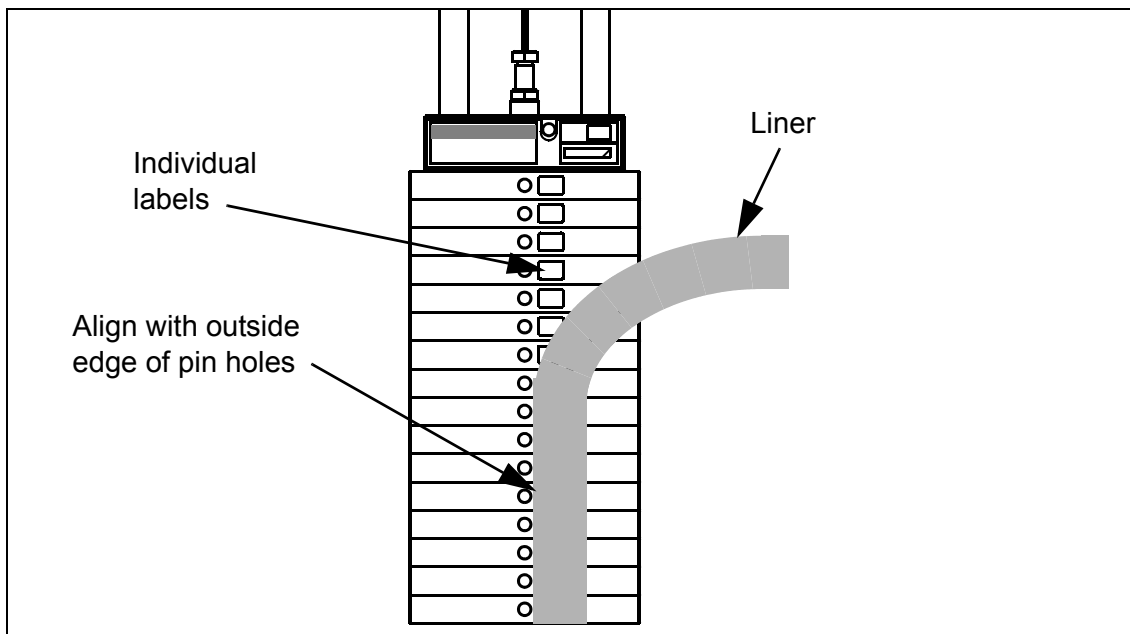



FINAL CHECK AND TESTING

1) CABLE CHECK.

Verify that the pulley housing is threaded into the cap plate 1-3/8" (35 mm) as shown.

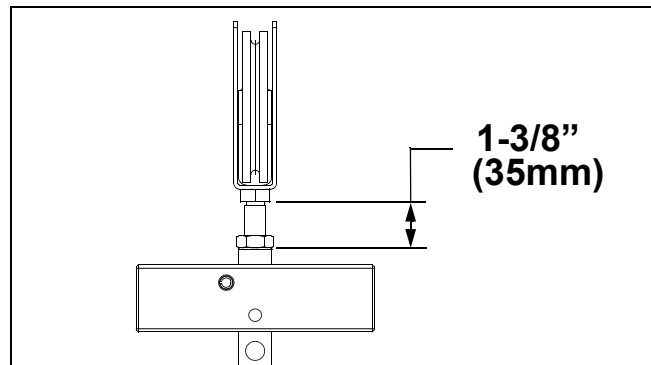

Place both arms in position "A" (upper position). Select the maximum weight on the weight stacks. Pull straight down on the cable. Ensure that the cable ball end fitting is in the position as shown and does not contact the swivel pulley housing.

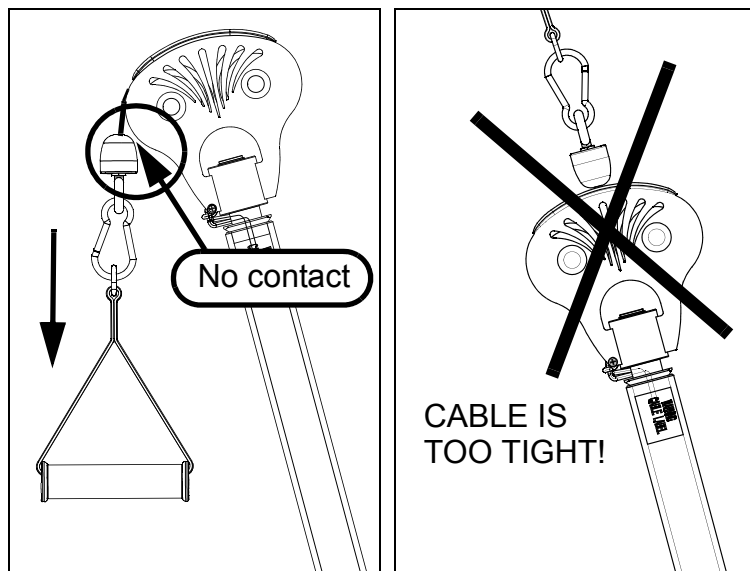

2) Verify that the cable is centered & seated in the groove of each pulley.

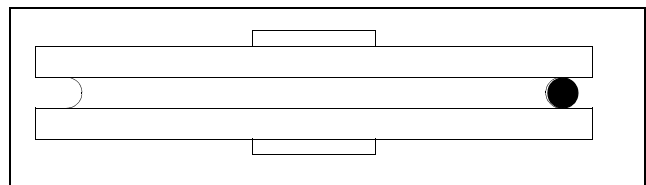

3) Adjustment Pins: Check the function of the selector pins on the adjustable arms. Make sure that each selector pin inserts completely into each position without binding.

4) Check the operation of each station through its full range of travel. Verify that it operates smoothly without binding or chattering. Try this at a few different weight settings.
TIP: After installing the weight plates, vigorously shake the weight stack to help align the weights.



5) The PFT-200 has provisions for anchoring the unit to the floor. Due to the wide variation of flooring on which the unit can be installed, contact a qualified contractor to determine the appropriate fastening system. COMPLETE THE FULL ASSEMBLY OF THE MACHINE BEFORE ANCHORING THE UNIT TO THE FLOOR.

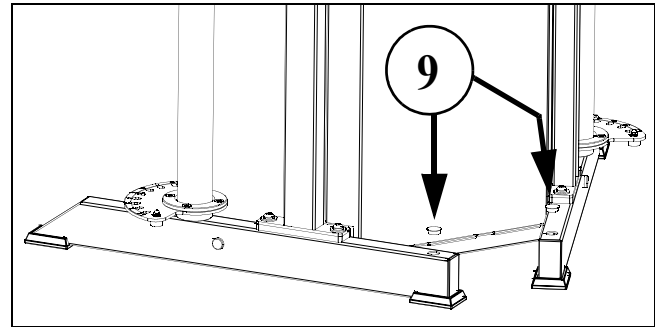

6) Lubricate the guide rods on each station by applying a light coating of Tri-Flow™ or other silicone spray lubricant. Spray the lubricant on a clean rag and wipe the guide rods with the rag. **DO NOT** use light oil base lubricants such as WD-40.

REPLACEMENT CABLE INFORMATION

MACHINE	DESCRIPTION	PART #	LENGTH
PFT-200-2	FUNCTIONAL TRAINER 2:1 RATIO Serial Number prior to (not including) PFT-22-0402001	PFT2007110A	201-3/4 in. (512 cm)
PFT-200-2	FUNCTIONAL TRAINER 2:1 RATIO	PFT2007210A	204-3/4 in. (520 cm)
PFT-200-2H	FUNCTIONAL TRAINER (HEAVY) 2:1 RATIO	PFT2007220A	200-1/4 in. (509 cm)
PFT-200-4	FUNCTIONAL TRAINER 4:1 RATIO Serial Number prior to (not including) PFT-24-0402001	PFT2007115A	304 in. (772 cm)
PFT-200-4	FUNCTIONAL TRAINER 4:1 RATIO	PFT2007215A	307 in. (780 cm)



PARAMOUNT

WARNING LABELS

The following warning labels are affixed to the machine. Be certain that you and the facility staff are aware of the meaning and importance of each label. If the labels become damaged, replacements can be obtained FREE of charge from Paramount.

⚠ WARNING

SERIOUS INJURY CAN OCCUR ON THIS EQUIPMENT IF THE CABLES AND THEIR ATTACHMENT COMPONENTS ARE NOT INSPECTED OFTEN. REPLACE AT FIRST SIGNS OF WEAR.

P/N B2051 6/96 ASTM Fxxx

B2051

⚠ WARNING

SERIOUS INJURY CAN OCCUR ON THIS EQUIPMENT IF THE PIN IS NOT COMPLETELY INSERTED BEFORE USE.

P/N B2065 11/96 ASTM Fxxx

B2065

⚠ WARNING

1. MAKE SURE selector pin is inserted completely. Use only the Paramount pin shown

2. Bolt height must not exceed 1 3/8". Check regularly. Make sure locking nut is tight.

ASTM F1749 P/N B2141

PIN

Paramount Pin P/n B 470

B2141

MAINTENANCE SCHEDULE	D	W
Check the integrity and function of the following items. Replace all worn components immediately	A	E
Check the integrity and function of the following items. Replace all worn components immediately	I	K
Check the integrity and function of the following items. Replace all worn components immediately	L	L
Check the integrity and function of the following items. Replace all worn components immediately	Y	Y
Cables - Check tension, end fittings, and coating. Check weight stack locking nut.	✓	✓
Upholstery - Wipe down and dry. Clean and condition.	✓	✓
Frame - Wipe down and dry. Polish/Wax	✓	✓
Chrome - Wipe down and dry. Polish/Wax	✓	✓
Nuts/Bolts/Fasteners - Tighten and/or adjust as needed.	✓	✓
Guide Rods - Lubricate and clean	✓	✓
Linear Rods - Lubricate and clean	✓	✓
Seat Sleeves - Lubricate and clean	✓	✓
Adjustments/Locking Pins/Tightening Knobs	✓	✓
Weight Stack Pin	✓	✓
Warning Instruction Labels	✓	✓
Springs	✓	✓
Anti-Skid	✓	✓
Handgrips	✓	✓
Order Paramount Service Kit P/N KIT-01 for recommended maintenance products		
PARAMOUNT CUSTOMER SERVICE 1-800-721-2121 P/N B2315		

B2315

PARAMOUNT FUNCTIONAL TRAINER

PARAMOUNT FUNCTIONAL TRAINER

B2606



Limited Warranty

Paramount warrants to the original purchaser from a Paramount authorized dealer that Paramount equipment will be free from defects in material and workmanship under normal use and service for the following periods and in the following respects:

LIFETIME WARRANTY - Welds, Weight Plates, and Guide Rods.

FIVE YEAR WARRANTY - Bronze Bushings, Sealed Rotating Bearings and Pulley Wheels.

ONE YEAR WARRANTY - Cables, Linear Bearings, Linear Shafts and all other components not mentioned elsewhere in this warranty.

90-DAY WARRANTY --Upholstery and Grips.

This limited warranty **DOES NOT** cover and no warranty is given with respect to:

1. Products not manufactured by Paramount
2. Products which are altered without the express written consent of Paramount
3. Products purchased other than directly from Paramount or through a Paramount authorized dealer.

All warranty periods begin to run from the date of delivery to the original purchaser. The obligation of Paramount under this warranty is limited to repairing or replacing warranted defective parts, as Paramount may elect, at Paramount's plant in Los Angeles, California, without charge to purchaser for either parts or labor. Purchaser is responsible for all transportation and insurance costs of returned or replaced equipment to and from Paramount's plant in Los Angeles.







ANY IMPLIED WARRANTY, INCLUDING BUT NOT LIMITED TO THE IMPLIED WARRANTY OF FITNESS FOR A PARTICULAR PURPOSE AND THE IMPLIED WARRANTY OF MERCHANTABILITY, IS LIMITED TO THE ONE YEAR DURATION FROM THE DATE OF DELIVERY TO THE ORIGINAL PURCHASER. SOME STATES DO NOT ALLOW LIMITATIONS ON HOW LONG AN IMPLIED WARRANTY LASTS, SO THE ABOVE LIMITATION MAY NOT APPLY TO YOU. THE REMEDY OF REPAIR AND REPLACEMENT IS THE EXCLUSIVE AND SOLE REMEDY OF THE PURCHASER. PARAMOUNT SHALL NOT BE LIABLE FOR ANY SPECIAL, INCIDENTAL, CONTINGENT OR CONSEQUENTIAL DAMAGES OF ANY KIND, INCLUDING, BUT NOT LIMITED TO, DAMAGE OR LOSS OF OTHER PROPERTY OR EQUIPMENT AND LOST PROFITS OR REVENUE. SOME STATES DO NOT ALLOW THE EXCLUSION OR LIMITATION OF INCIDENTAL OR CONSEQUENTIAL DAMAGES SO THE ABOVE LIMITATION OR EXCLUSION MAY NOT APPLY TO YOU.

No action for breach of this written limited warranty or any implied warranty shall be commenced more than one year after the accrual of the cause of action. This written limited warranty is the complete, final and exclusive agreement of the parties with respect to the quality or performance of the goods and any and all warranties and representations. No modification of this limited warranty or waiver of its terms shall be binding on either party unless approved in writing by an authorized corporate officer of Paramount. This limited warranty gives you specific legal rights, and you may also have other rights which vary from state to state. Contact Paramount Fitness Corp., 6450 E. Bandini Blvd., Los Angeles, California 90040-3185, before returning any defective equipment. Paramount Fitness Corp. © 2002.

PARAMOUNT FITNESS CORP.
6450 E. Bandini Blvd., Los Angeles, CA 90040-3185 USA
1-800-721-2121

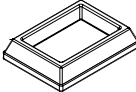
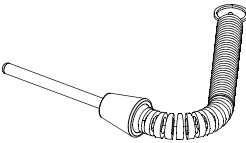

PFT-200 HARDWARE BAG

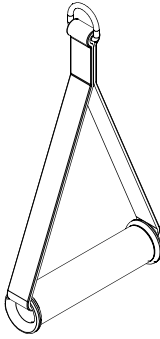
ITEM	DESCRIPTION		QTY	PART #
1	HOOK, ACCESSORY		2	PFT2003008
2	1/4" LOCK WASHER		4	C 747
3	1/4" FLAT WASHER		4	C 752
4	BUTTON HEAD SCREW, 1/4-20 X 3/4 lg.		4	C 675B
5	MOLDED PARAMOUNT FOOT		4	B 751
6	SELECTOR PIN, MAGNETIC		2	B 470
7	SNAP HOOK		2	B1005
8	HANDLE, NYLON STRAP		2	B1110
9	HOLE PLUG, 1" DIAMETER, BLACK		2	B1216