

# Panasonic®

Dual DIN in-dash HDD Mobile Navigation System with 7" Widescreen Color LCD Monitor/DVD Receiver

Système de navigation embarqué à disque dur de format 2-DIN avec récepteur DVD/moniteur couleur ACL grand écran de 7 po

Sistema de navegación portátil de doble DIN para tablero de mandos, con disco duro y monitor LCD panorámico de 7" en color y receptor con DVD

---

## CN-NVD905U

### Installation Instructions Instructions d'installation Instrucciones de instalación

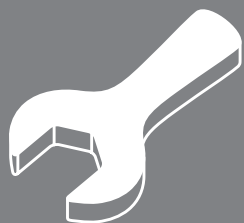









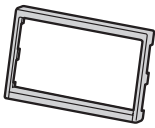
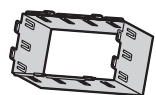
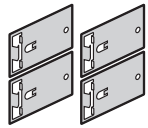







- Read the "Safety information" presented in the Operating Instructions before mounting or connecting this product.
- Avant le montage ou le branchement du présent produit, veuillez lire les « informations sur la sécurité » décrites dans le manuel d'instructions.
- Lea la "Información de seguridad" que aparece en las Instrucciones de funcionamiento antes de montar o conectar este producto.

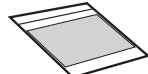

# Installation hardware

English

## ■ For installation

						
① Trim plate YEFC041589B Qty: 1	② Mounting collar YEFG013081A Qty: 1	③ Mounting spring YEFX0052513 Qty: 4	④ Rear support strap YEFG04019 Qty: 1			
						
⑤ Mounting bolt (5 mmφ) Qty: 1	⑥ Tapping screw (5 mmφ × 16 mm) Qty: 1	⑦ Hex. nut (5 mmφ) Qty: 1	⑧ Round head screw (5 mmφ × 6 mm) Qty: 4	⑨ Flat-Head screw (5 mmφ × 6 mm) Qty: 8	⑩ Spacer Qty: 4	⑪ Double-Faced Adhesive Tape Qty: 4
YEPOFZ5810 Qty: 1						
						
⑫ Clip connector Qty: 4	⑬ Protection sheet Qty: 1	⑭ Cord clamper Qty: 5	⑮ Wiping Cloth Qty: 1			
YEPOFZ5811 Qty: 1						
						
⑯ GPS antenna Qty: 1	⑰ Rubber water seal Qty: 1	⑱ Metal sheet Qty: 1				
YEPOFZ5726 Qty: 1						

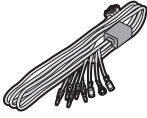
## ■ For wiring

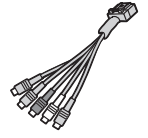
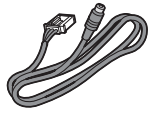
				
⑲ Power connector YEAJ012837A Qty: 1	⑳ Speed Pulse Cable YEAJ071554 Qty: 1	㉑ Vehicle signal connector YEAJ071720 Qty: 1	㉒ AV connector K1V912Y10001 Qty: 1	㉓ Rear view camera - RCA conversion cable YEAJ071818 Qty: 1

2

Car navigation unit, Instruction kit  
(⇒ Operating Instructions)

2

# Contents

---

English

---

Français

---

Español

---

<b>Installation hardware</b> .....	2
<b>Contents</b> .....	3
<b>Installation guide</b> .....	4
<b>Mounting and removing the unit</b> .....	6
<b>Mounting the GPS antenna</b> .....	8
<b>Electrical connections</b> .....	10
<b>External unit connections</b> .....	12

**Note:**

- The number in parentheses underneath each accessory part name is the part number for maintenance and service.
- Accessories and their parts numbers are subject to modification without prior notice due to improvements.
- Use the supplied screws for installation exclusively. In case of loss, please order the specific screw.

# Installation guide

## ■ Transportation bracket removal

Be sure to remove the transportation brackets before use (installation). **Use round head screws (5 mm  $\phi$   $\times$  6 mm) for installation.** (→ page 7)

Be careful not to lose these screws.

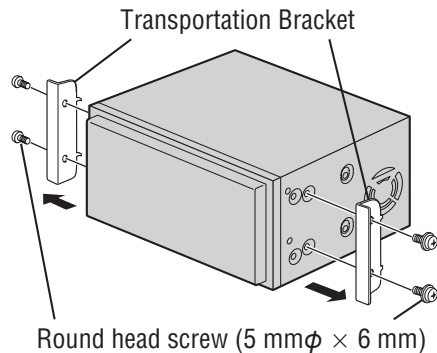

## ■ Before installation

### ⚠ Warning

This product is designed for operation with a negative grounded 12 V DC battery system. Never operate this product with other battery systems, especially a 24 V DC battery system. If it is used in the wrong type of car, it may cause a fire or an accident.

- Do not press the panel forcefully.
- Do not scratch the panel with fingernails or any hard objects.
- Do not bump the front panel.
  - Failure to observe the above may damage or break the glass on the surface of the touch panel.

## ■ Required tools

You'll need a screwdriver and the following:

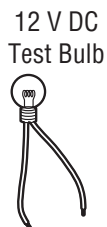

## ■ Dashboard specifications

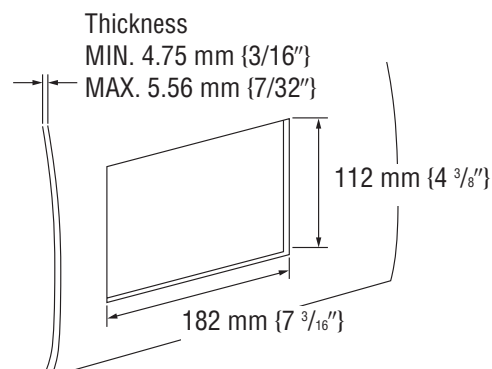

## ■ Identify all leads

The first step in installation is to identify all the car wires you will use when hooking up this unit.

As you identify each wire, we suggest that you label it using masking tape and a permanent marker. This will help avoid confusion when making connections later.

### Note:

- Do not connect the power connector to this unit until you have made all connections. If there are no plastic caps on the hooking wires, insulate all exposed leads with electrical tape until you are ready to use them. Identify the leads in the following order.

### Power lead

If your car has a radio or is pre-wired for one:

Cut the connector wires one at a time from the plug (leaving the leads as long as possible) so that you can work with individual leads. Turn the ignition on to the accessory position, and ground one lead of the test bulb to the chassis.

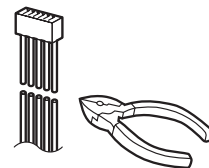

Touch the other lead of the test bulb to each of the exposed wires from the cut radio connector plug. Touch one wire at a time until you find the outlet that causes the test bulb to light.

Now turn the ignition off and then on. If the bulb also turns off and on, that outlet is the car power lead.

If your car is not wired for an audio unit: Go to the fuse block and find the fuse port for radio (RADIO) accessory (ACC) or ignition (IGN).

### Battery lead

If this unit has a yellow lead, you will need to locate the car's battery lead. Otherwise you may ignore this procedure. (The yellow battery lead provides continuous power to maintain a clock or other functions.)

If your car has a radio or is pre-wired for one: With the ignition and headlights off, identify the car battery lead by grounding one lead of the test bulb to the chassis and checking the remaining exposed wires from the cut radio connector plug.

If your car is not wired for an audio unit: Go to the fuse block and find the fuse port for the battery, usually marked BAT.

### Speakers (not supplied)

Identify the car speaker leads. There are two leads for each speaker, usually color coded. A handy way to identify the speaker leads and the speaker they are connected to is to test the leads using a 1.5 V AA battery as follows.

Hold one lead against one pole of the battery and stroke the other lead across the other pole. You will hear a

scraping sound in a speaker if you are holding a speaker lead.

If not, keep testing different lead combinations until you have located all the speaker leads. When you label them, include the speaker location for each.

## ■ Connect all leads

Now that you have identified all the wires in the car, you're ready to begin connecting them to this unit wires. Electrical Connections (⇒ page 10 – 11) shows the proper connections and color coding of the leads.

We strongly recommend that you test the unit before making a final installation.

You can set the unit on the floor and make temporary connections to test the unit. Use electrical tape to cover all exposed wires.

### Important:

Connect the red power lead last, after you have made and insulated all other connections.

### Ground

Connect the black ground lead of the power connector to the metal car chassis.

### Speakers

Connect the speaker wires. See the wiring diagram for the proper hookups. Follow the diagram carefully to avoid damaging the speakers and this unit.

The speakers used must be able to handle more than 50 W of audio power. If using optional audio power, the speakers should be able to handle the maximum amplifier output power. Speakers with low input ratings can be damaged.

Speaker impedance should measure 4 – 8  $\Omega$ , which is typically marked on most speakers. Lower or higher impedance speakers will affect output and can cause both speaker and this unit damage.

### Battery

Connect the yellow battery lead to the correct radio wire or to the battery fuse port on the fuse block.

### Equipment

Connect any optional equipment according to the instructions furnished with the equipment. Read the operating and installation instructions of any equipment you will connect to this unit.

### Power

Connect the red power lead to the correct car radio wire or to the appropriate fuse port on the fuse block.

If this unit functions properly with all these connections made, disconnect the wires and proceed to the final installation.

## ■ Final installation

### Lead connections

Connect all wires, making sure that each connection is insulated and secure. Bundle all loose wires and fasten them with tape so they will not fall down later. Now insert this unit into the mounting collar.

Congratulations! After making a few final checks, the new unit is ready for use.

## ■ Final checks

1. Make sure that all wires are properly connected and insulated.
2. Make sure that this unit is securely held in the mounting collar.
3. Turn on the ignition to check the unit for proper operation.

If you have difficulties, consult your nearest authorized professional installer for assistance.

## ■ Precautions

- Disconnect the cable from the negative (–) battery terminal.
- Unit should be installed in a horizontal position with the front end up at a convenient angle, but less than 30°.

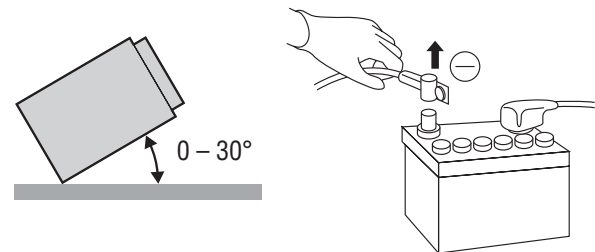

This unit should be professionally installed. In case of difficulty, please consult with your nearest professional installer.

1. This unit only operates in a 12 V DC negative ground system.
2. Follow the electrical connections carefully (⇒ page 10 – 11). Failure to do so may result in damage to the unit.
3. Connect the power lead after all other connections are made.
4. Be sure to connect the battery lead (yellow) to the positive terminal (+) of the battery or fuse block (BAT) terminal.
5. Insulate all exposed wires to prevent short circuiting.
6. Secure all loose wires after installing the unit.
7. Please carefully read the operating and installation instructions of the respective equipment before connecting it to this unit.

# Mounting and removing the unit

## Mounting procedures (A) (When using Mounting collar ②)

### IMPORTANT

When this unit is installed in a dashboard, ensure that there is sufficient air flow around the unit to prevent damage from overheating. Do not block any ventilation holes on the unit.

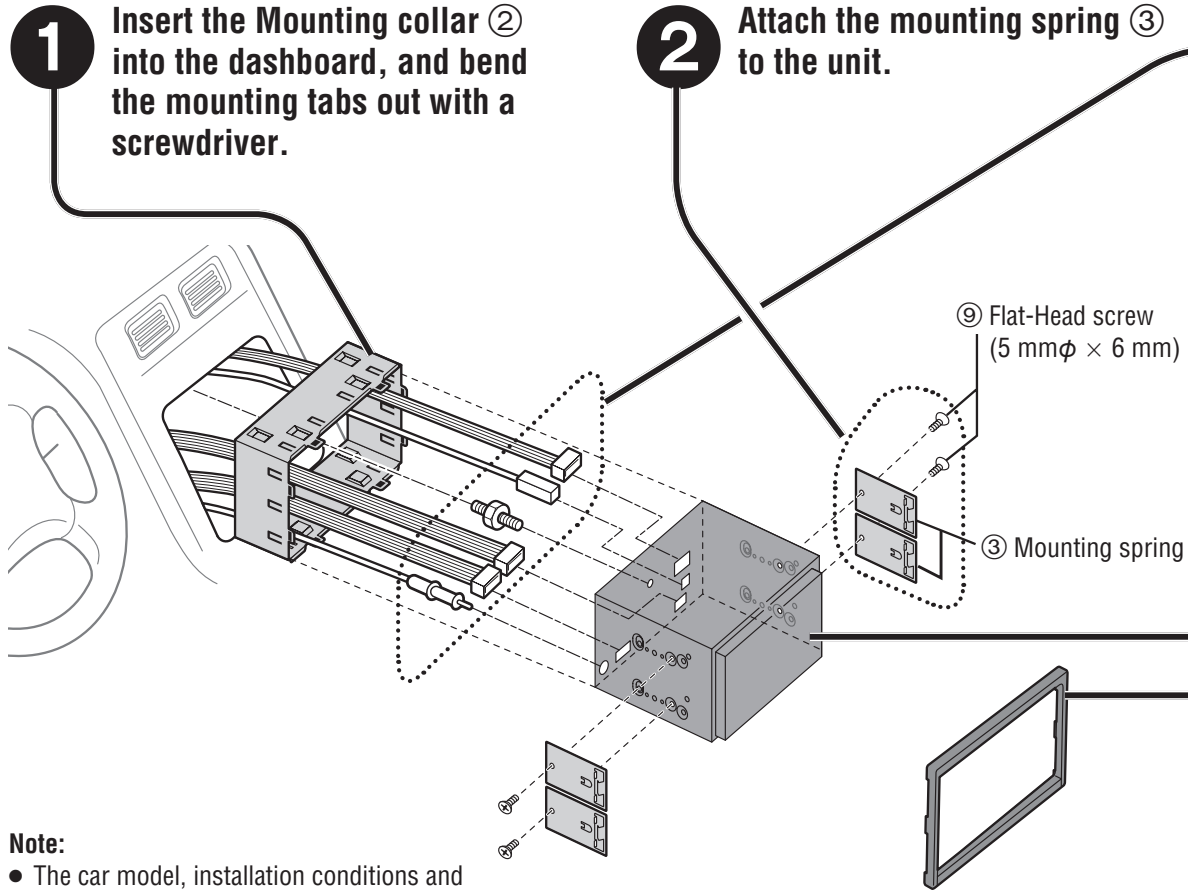

### Note:

- The car model, installation conditions and combination of the units used may impose some restrictions on opening and closing the monitor as well as on the angle and position to which the monitor can be adjusted.

## Method for fixing the rear of the unit

### (a) Using the Rear support strap ④.

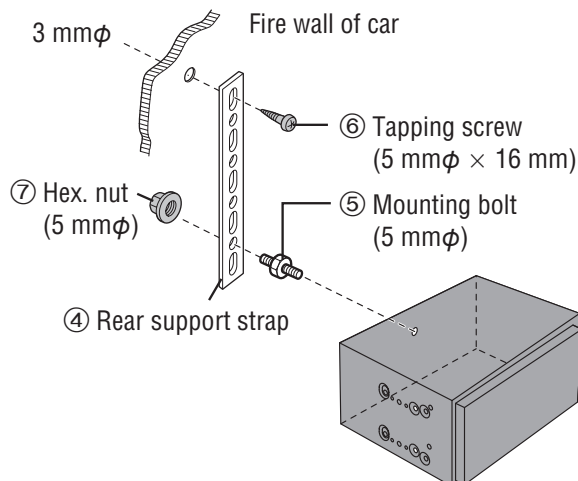

### (b) Using the Rubber cushion (option)

Rear support bracket  
(Provided on the car)

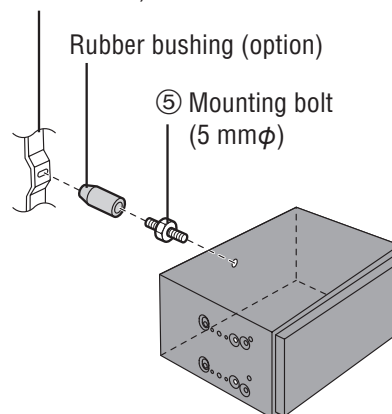

### 3 Establish the rear connection of the unit.

After fixing Power connector ⑱, fix the rear of the unit to the car body by either method (a) or (b).

### 4 Insert the unit into Mounting collar ②.

Secure the clamp plate of Mounting collar ② to the hook.

### 5 Insert trim plate ①.

Snapping point

Snapping point

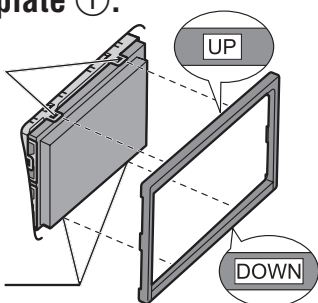

### 6 After installation reconnect the negative (-) battery terminal.

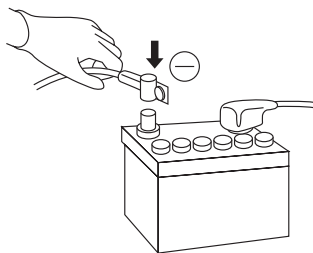

## Removing procedures

- 1 Insert two flathead screwdrivers between the unit and the mounting collar, then detach the four hooks.

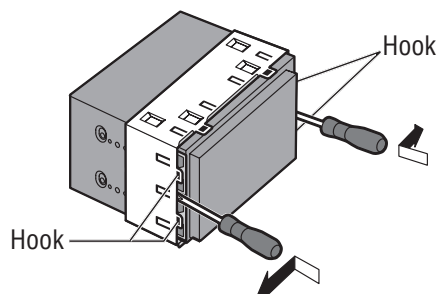

- 2 Hold the unit and pull it forward until the hooks are visible.

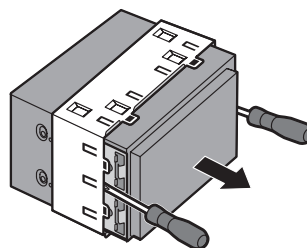

- 3 Remove the screwdrivers and pull the unit out with both hands.

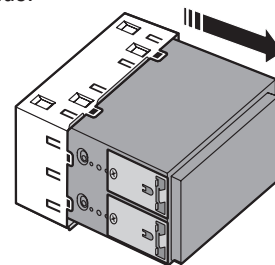

## Mounting procedures (B) (When not using Mounting collar ②)

Use the brackets supplied with your car when mounting this unit. The bracket shape and mounting method vary with car manufacturers, car types and manufacturing year. Please consult your nearest dealer or installer.

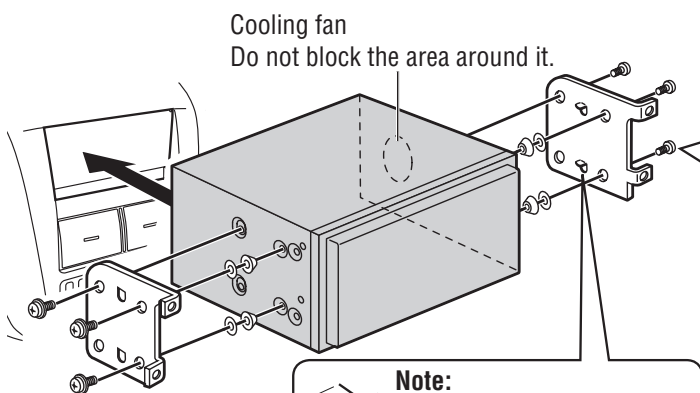

**Note:**  
Use pliers to bend the fingers on the bracket vertically.

Select mounting screws according to the hole positions and hole shape of the bracket.

⑧ Round head screw  
(5 mm  $\phi$  × 6 mm)

**Note:**  
Reuse the round head screws that fixed the transportation brackets for two more positions. (→ page 4)

⑨ Flat-Head screw  
(5 mm  $\phi$  × 6 mm)

# Mounting the GPS antenna

## Preparation:

- Wipe all dirt (oil, dust, etc.) off the mounting surface, and dry any moisture.
- If the air temperature is low, use a hair drier, etc. to warm the mounting surface.
- To avoid interference, mount the GPS antenna at least 10 cm away from any other antenna.

## External mounting (recommended)

### Mount the GPS antenna on a flat part of the roof.

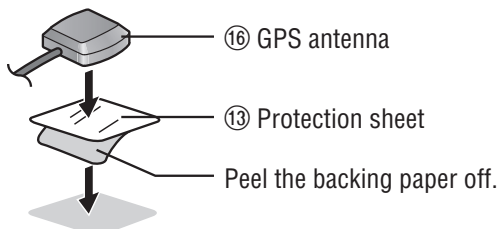

\* Mounting the antenna close to a luggage carrier or on the trunk lid impairs reception of signals from the GPS satellites.

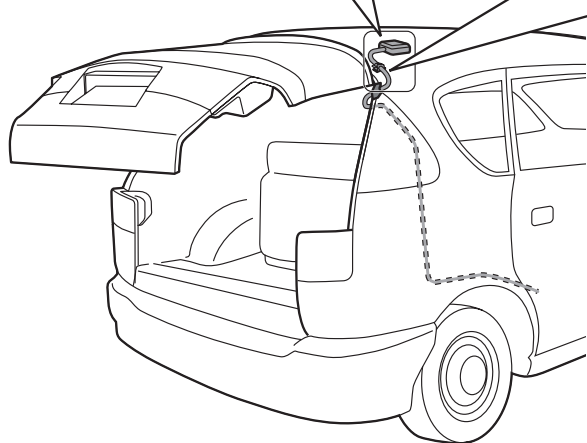

### Route the cord so that it does not allow rainwater into the vehicle.

- If the vehicle is a hatchback, allow enough slack in the cord so that it does not get pulled when the rear door is opened or closed.

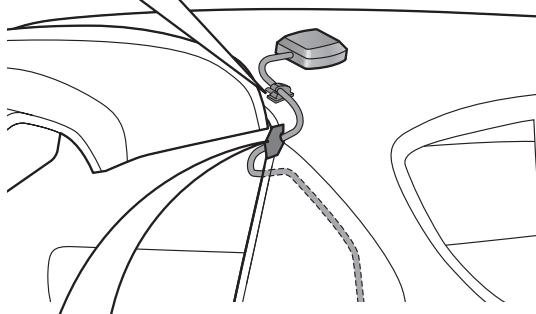

### GPS antenna cord



Place parallel to the trunk gasket.

Turn over

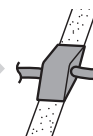

## Note:

- Keep paint, wax, etc. off the GPS antenna. Also, remove substances such as snow from the antenna when they accumulate. These substances impede GPS signal reception.
- Always remove the GPS antenna before using a car wash. When removing it, take care not to pull on the cord, as that could cause damage or a malfunction.



## Mounting on the dashboard or rear tray

Mount the antenna horizontally, in the center of the dashboard and close to the windshield.

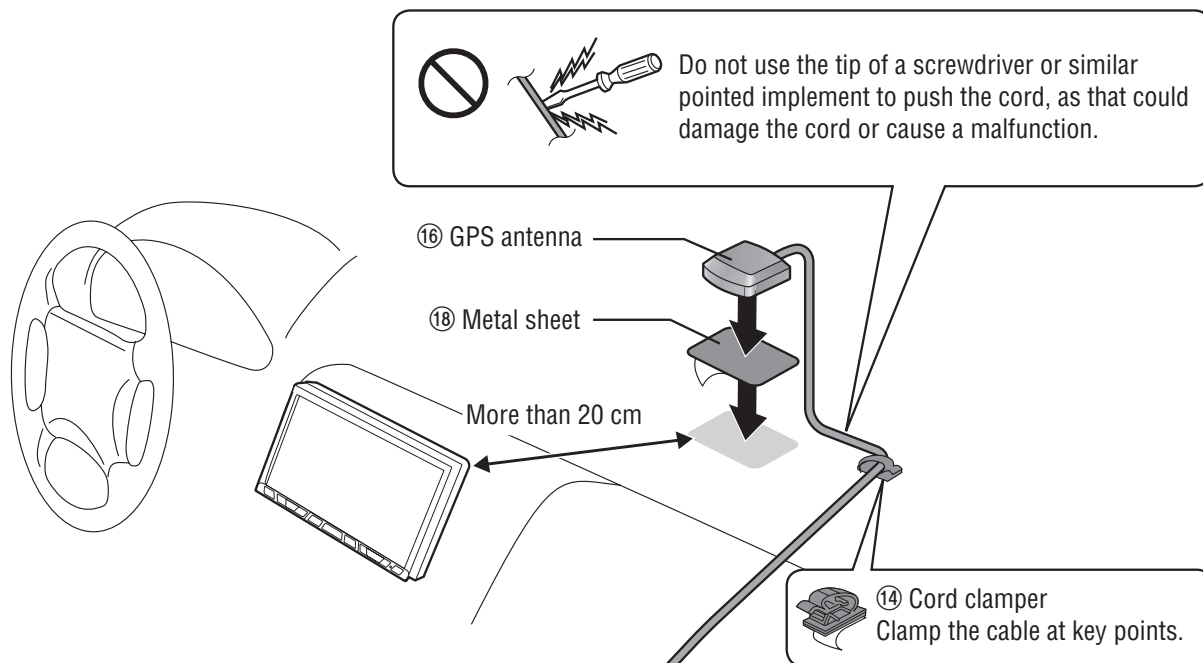

### Note:

- Mounting the antenna inside the vehicle impedes reception, and may cause incorrect indication of vehicle position, depending on the strength of the signal. Mount the antenna outside the vehicle if reception is unsatisfactory.

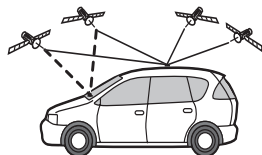

- The GPS signal may be blocked by the shape of the vehicle body or by a windshield or side window.

- Be sure to use the metal sheet provided.
- Do not fold it or cut it smaller.
- If you bundle up the excess antenna cord, keep it at least 30 cm away from the navigation unit.
- Keep watches and magnetic cards away from the GPS antenna. The watch or card could malfunction or become unusable.

# Electrical connections

## ⚠ Warning

This product is designed for operation with a negative grounded 12 V DC battery system. Never operate this product with other battery systems, especially a 24 V DC battery system. If it is used in the wrong type of car, it may cause a fire or an accident.

- To prevent from damage to the unit, be sure to follow the wiring diagrams below.
- Be sure to fully plug in the connectors. Secure them with clamps and tapes.
- All other installation methods require the use of dedicated metal fittings. Consult with a qualified servicing engineer or your dealer if other methods are required.

**When disconnecting a locked cable, press the lock in the arrowed direction while removing the connector.**

- Pulling too strongly will break the connector. Check that the lock is disengaged before trying to disconnect the connector.

### Power connector

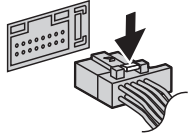

### Vehicle signal connector

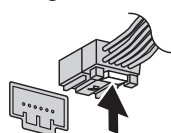

### AV connector

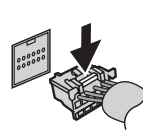

### GPS antenna connector

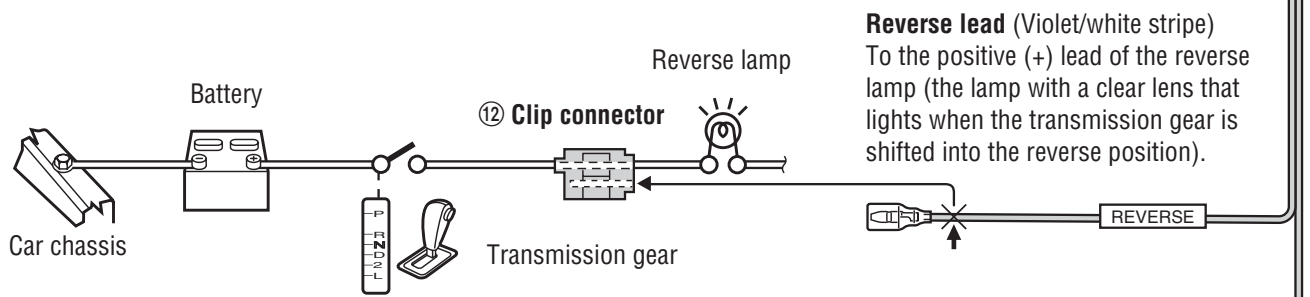
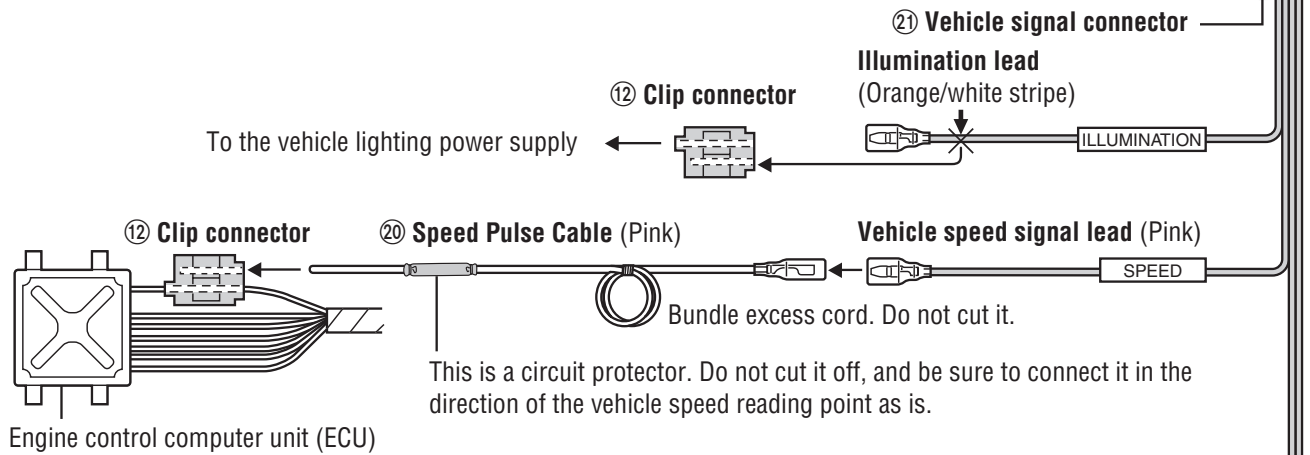
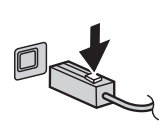

### How to attach a clip connector

- 1 Insert the cable into the clip connector.  

Vehicle-side wiring cable

Parking brake connection lead of this unit (Example)
- 2 Press the element into place.
- 3 Close the cover.

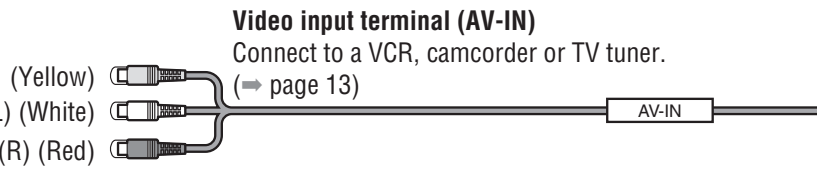
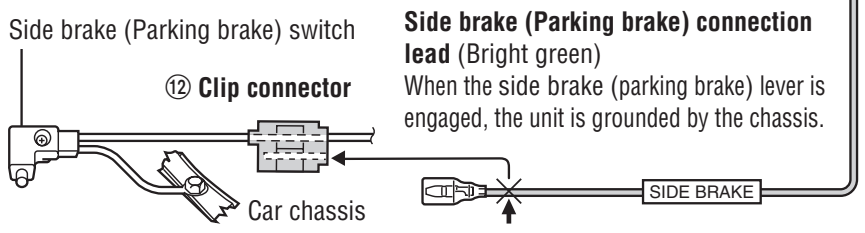

**System-up connector**

To external devices equipped with system-up connector.

**Data 1 connector**  
(available in future)

**Data 2 connector**  
(available in future)

⑯ **GPS antenna**

**REMOTE OUT connector**  
To the REMOTE IN connector of a TV tuner

**CN-NVD905U (Rear)**

**Fuse (15 A)**  
Refer fuse replacement to your nearest authorized Panasonic Servicenter. Do not attempt fuse replacement by yourself.

**Radio antenna connector (RADIO ANT IN)**

This navigation system cannot be installed in a vehicle that does not have an ACC (accessory) position on the ignition switch.

**Rear view camera connector**  
Connect a rear view camera (⇒ page 12)

⑳ **AV connector**

⑲ **Power connector**

**Fuse (3 A)**

**Fuse (5 A)**

**Noise filter**

**Power lead (Red)**  
To ACC power, +12 V DC.

**Battery lead (Yellow)**  
To the car battery, continuous +12 V DC.

**Ground lead (Black)**  
To a clean, bare metallic part of the car chassis.

**Motor antenna relay control lead (Blue)**  
To motor antenna (Max. 100 mA)

• This lead is not intended for use with a switch actuated power antenna.

**FRONT L** **Front left + (White)**  
**FRONT L** **Front left - (White/black stripe)**

**FRONT R** **Front right + (Gray)**  
**FRONT R** **Front right - (Gray/black stripe)**

**REAR L** **Rear left + (Green)**  
**REAR L** **Rear left - (Green/black stripe)**

**REAR R** **Rear right + (Violet)**  
**REAR R** **Rear right - (Violet/black stripe)**

**AMP CONT MAX 0.1 A** **External amplifier control power lead (Blue/white stripe)**

To an external amplifier or a power control lead of the TV tuner.  
• Connect both the power control lead of the TV tuner and the amplifier control connector of the external amplifier when the TV tuner and external amplifier are connected at the same time.

**PRE-OUT FRONT** **Pre-out connector (Front)**  
To an external amplifier.

**PRE-OUT REAR** **Pre-out connector (Rear)**  
To an external amplifier.

**S.W.-OUT** **Pre-out subwoofer connector (Mono)**  
To an external amplifier.

**Speaker connections**

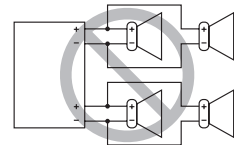
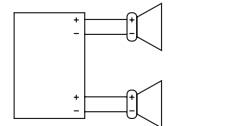

- Do not connect more than one speaker to one set of speaker leads (except for connecting to a tweeter).
- Do not use a 3-wire type speaker system having a common earth lead.
- Use ungrounded speakers only.  
Allowable input : 50 W or more.  
Impedance : 4 – 8 Ω  
**Use of speakers which do not match the specifications can cause burning, smoking or damage of the speakers.**

# External unit connections

Also refer to the operating instructions for the connected devices.

## Connecting to the System-up connector

- The devices below can be connected.  
Use an Expansion module (CY-EM100U, option) if you need to connect two or more devices.

### iPod®

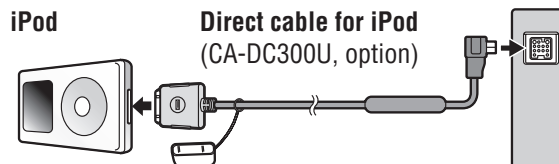

### Hands-free kit (CY-BT100U)



### SIRIUS Satellite Radio Tuner (SIR-PAN1)

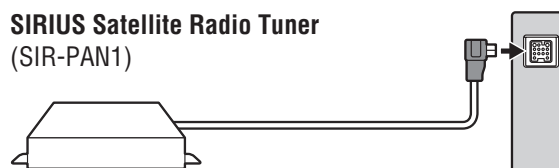

### XM Satellite Radio Tuner (XMD1000)

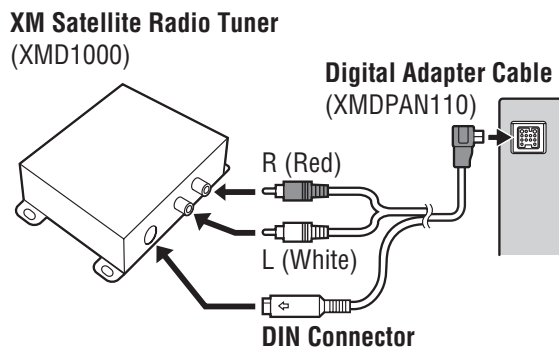

## Rear view camera

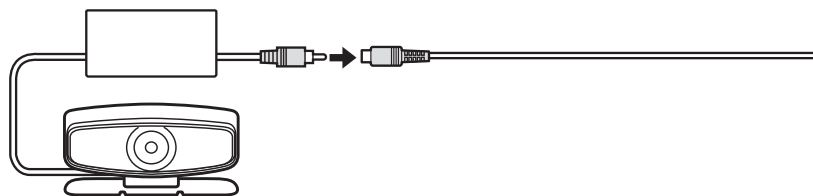

## Rear monitor (CY-VHD9401U)

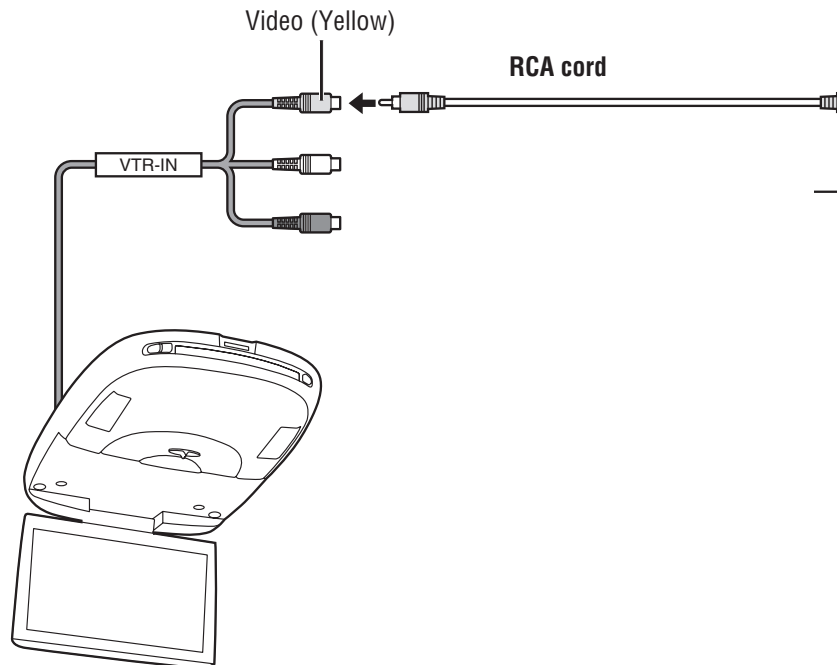

**Overhead 9' Widescreen Color LCD Monitor with Built-in DVD Player**  
(CY-VHD9401U, option)

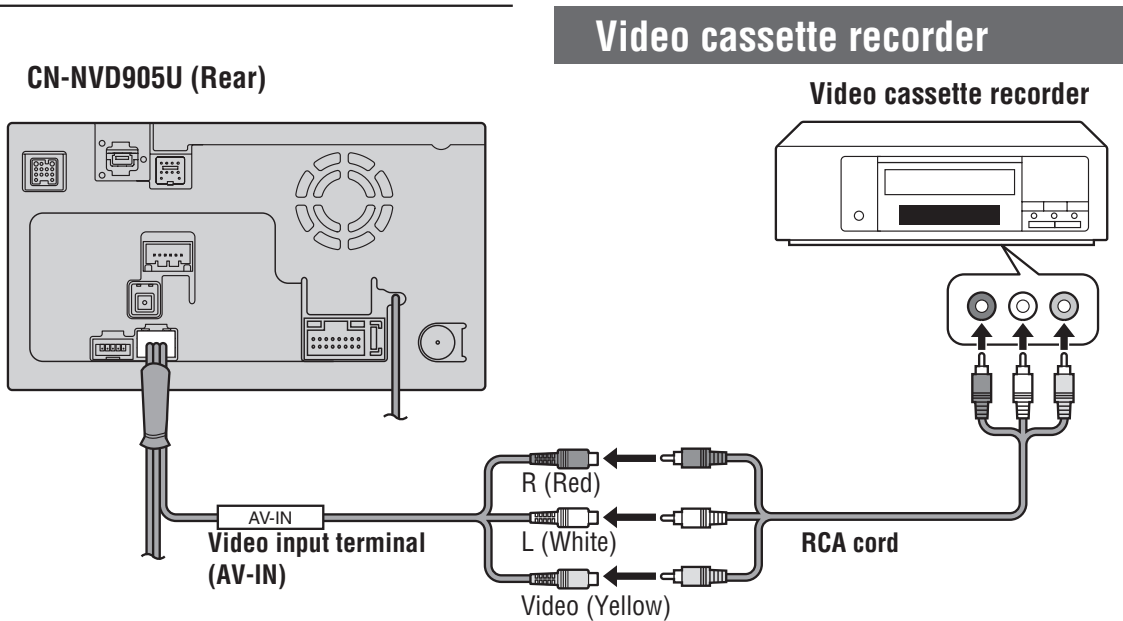
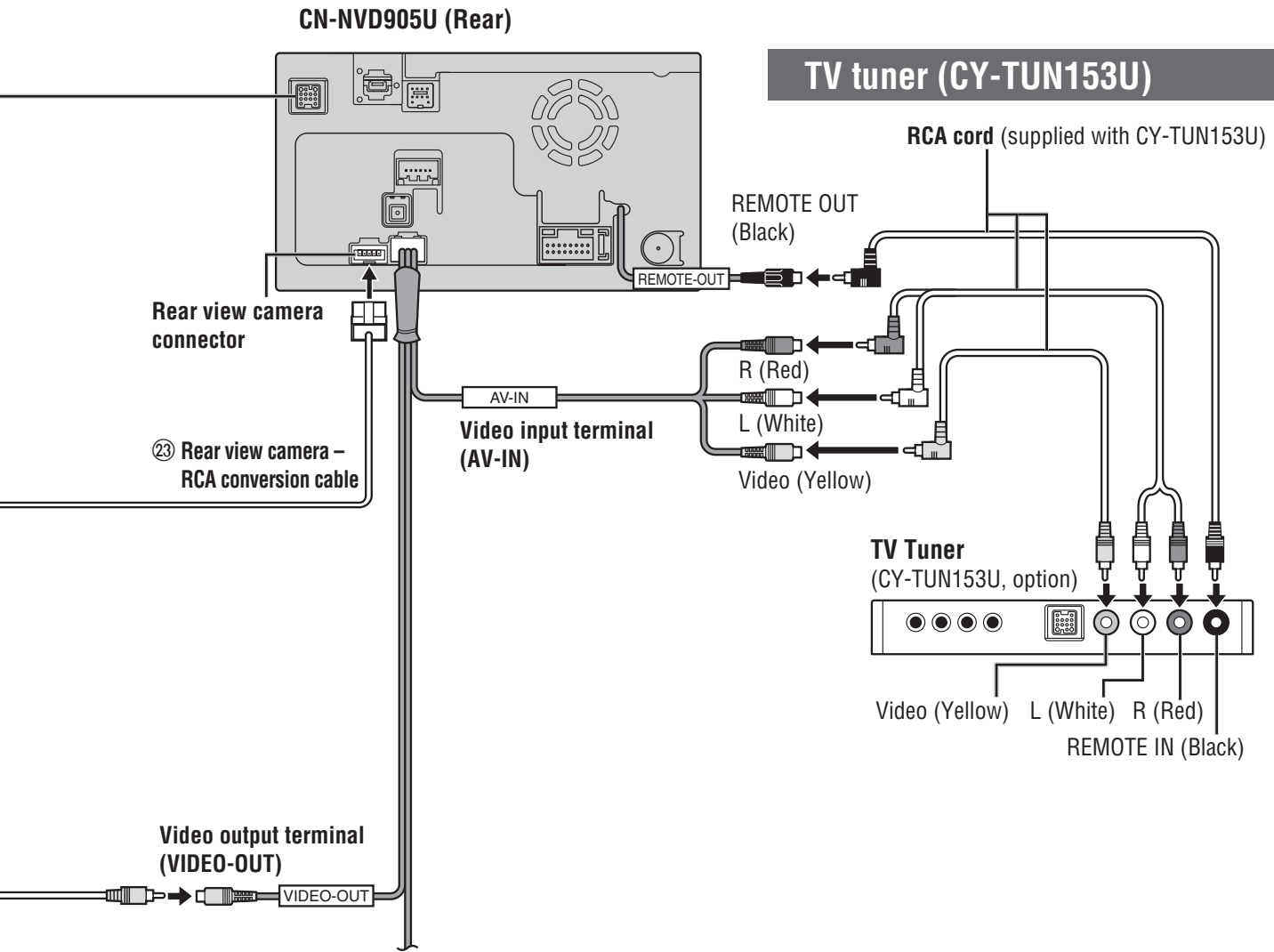

# External unit connections (continued)

## Connection with expansion module (CY-EM100U)

If you use an Expansion module (CY-EM100U, option), you will also be able to connect an iPod, hands-free kit, SIRIUS Satellite Radio Tuner or XM Satellite Radio Tuner.

- If multiple devices of the same type are connected at the same time, this unit will only recognize one of them. (For example, if three iPods are connected, only one will be recognized.)

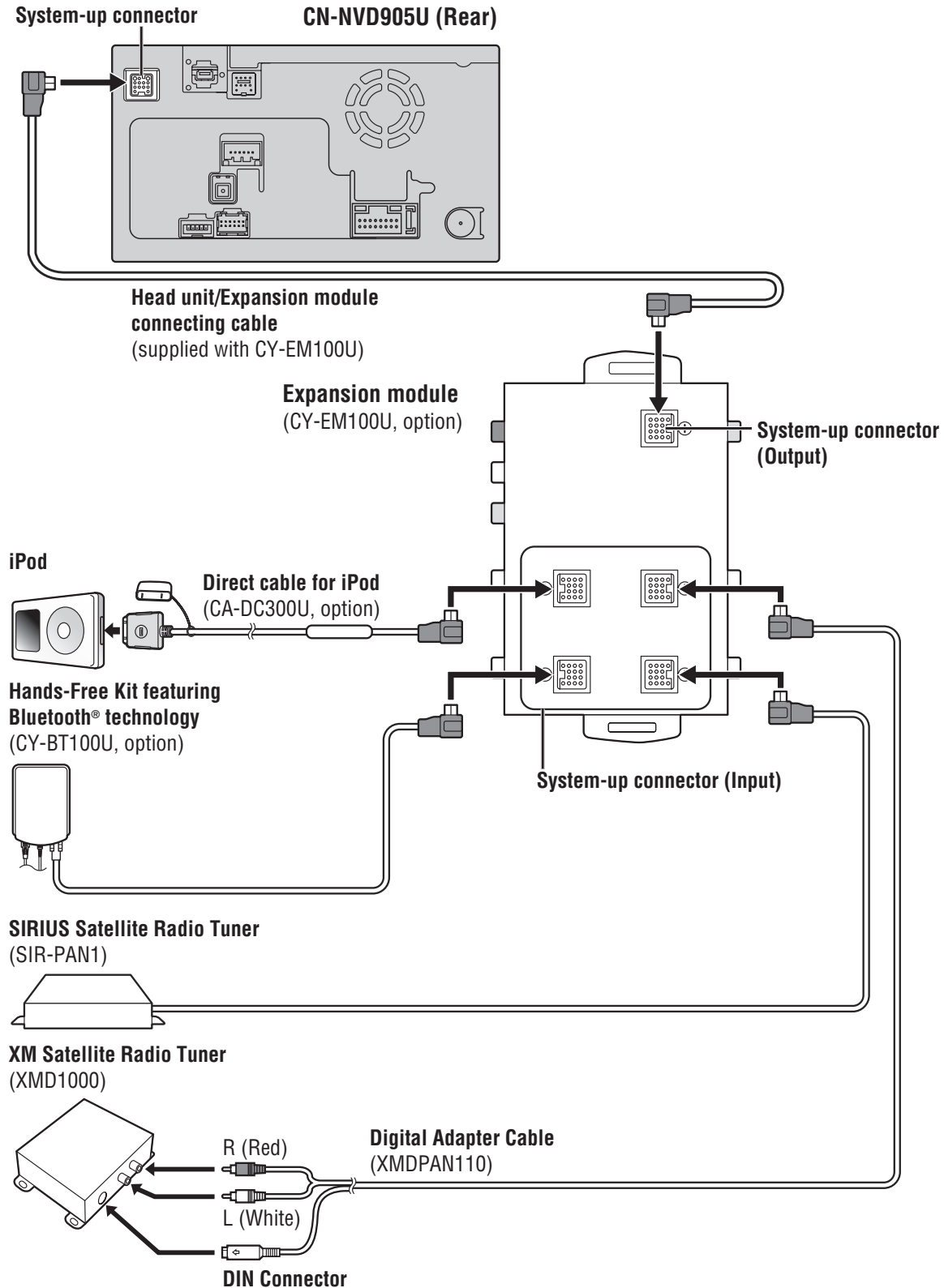



**Panasonic Consumer  
Electronics Company,  
Division of Panasonic  
Corporation of North America**  
One Panasonic Way, Secaucus,  
New Jersey 07094  
<http://www.panasonic.com>

**Panasonic Puerto Rico, Inc.**  
Ave. 65 de Infanteria, Km. 9.5  
San Gabriel Industrial Park,  
Carolina, Puerto Rico 00985  
<http://www.panasonic.com>

**Panasonic Canada Inc.**  
5770 Ambler Drive,  
Mississauga, Ontario  
L4W 2T3  
<http://www.panasonic.ca>

© 2007 Matsushita Electric Industrial Co., Ltd. All Rights Reserved.  
© 2007 Matsushita Electric Industrial Co., Ltd. Tous droits réservés.

YEFM285973 F0107-1037

Printed in Japan  
Imprimé au Japon  
Impreso en Japan