

Version: 1PA026A1

Date: May.21.2004

SERVICE MANUAL

MA-101-C

WIRELESS AMPLIFIER

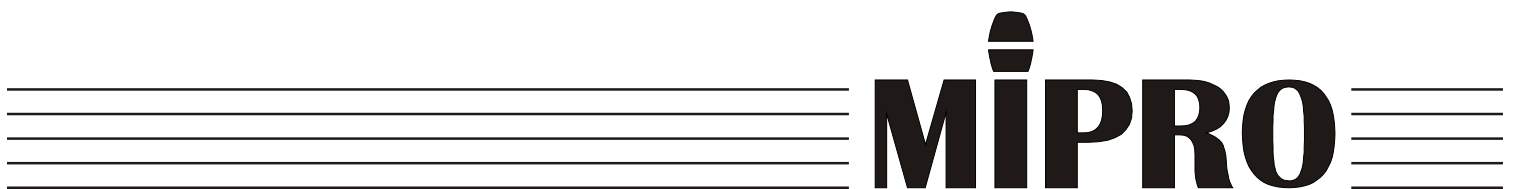

SPECIFICATIONS FOR MA-101-C AMPLIFIER

ITEM	SPECIFICATIONS
1. POWER SUPPLY	12/2.7AH rechargeable battery and intelligent charger or 18VDC/90-264VAC Switch Power
2. POWER OUTPUT	20W(RMS)/4Ω(Load)
3. FREQUENCY RESPONSE	50Hz-20KHz ±3dB
4. LINE INPUT	Line-in 3.5 socket
5. MIC INPUT	Mic-in 6.3 socket
6. SPEAKER	Built-in 5 inch high sensitivity full range speaker
7. CHARGING TIME	4hrs(Automatic rechargeable battery management)
8. OPERATING TIME	8hrs
9. DIMENSION(M/M)	285(L)X160(W)X178(H)
10. WEIGHT	2.5Kgs
11. COLOR	Black or ivory white is available

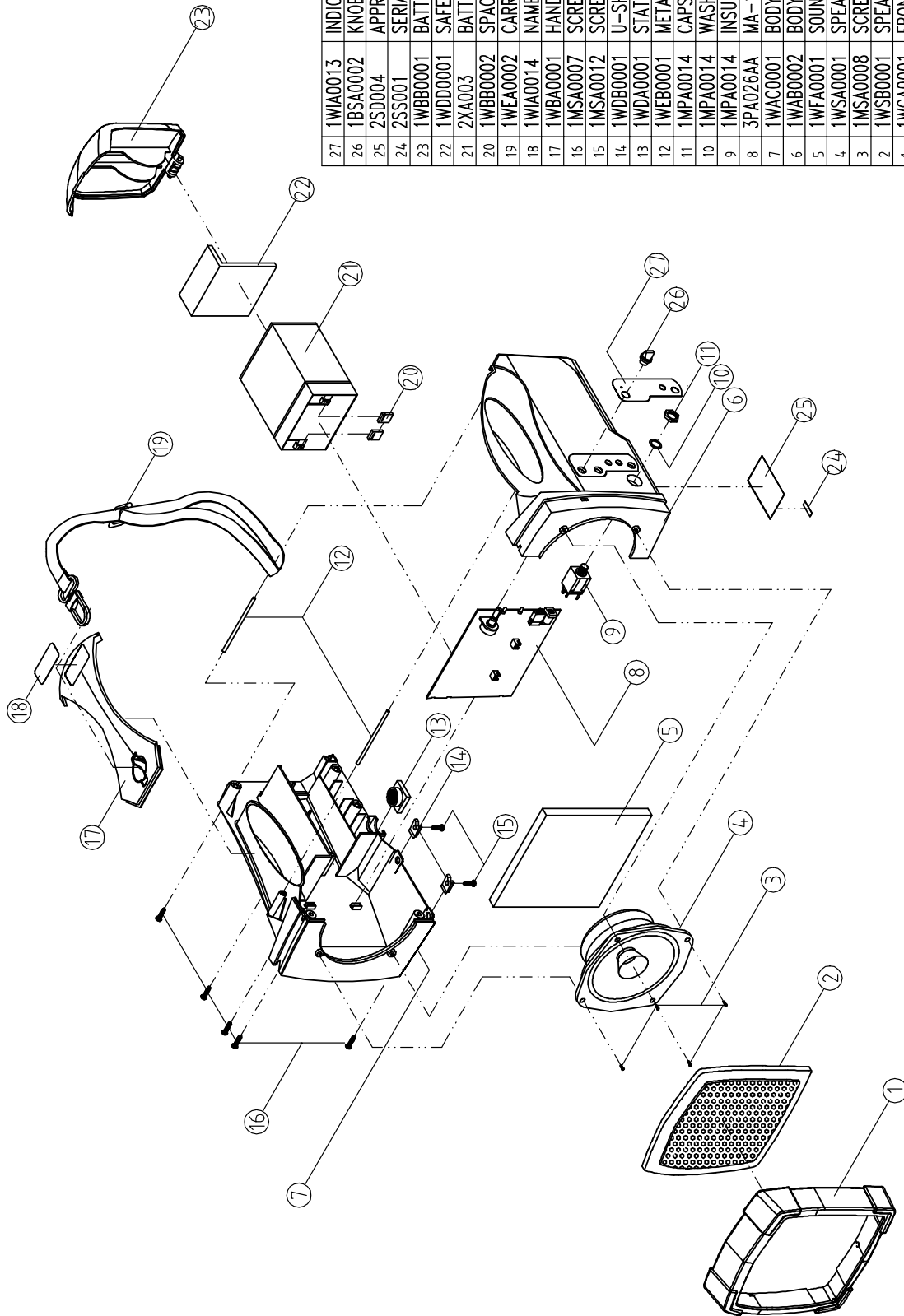

NO.	SERIAL NO.	DESCRIPTION	Q'TY
27	1WIA0013	INDICATOR PLATE	1
26	1BSA0002	KNOB	1
25	2SD004	APPROVED STICKER	1
24	2SS001	SERIAL NO. STICKER	1
23	1WBB0001	BATTERY COVER	1
22	1WDD0001	SAFETY PLATE	1
21	2XA003	BATTERY	1
20	1WBB0002	SPACER	2
19	1WEA0002	CARRY BELT	1
18	1WIA0014	NAME PLATE	1
17	1WBA0001	HAND HANDLE	1
16	1MSA0007	SCREW	5
15	1MSA0012	SCREW	2
14	1WDB0001	U-SHAPE HOOK	2
13	1WDA0001	STATIONARY POSITION	1
12	1WEB0001	METAL ROD	2
11	1MPA0014	CAPS NUT	1
10	1MPA0014	WASHER	1
9	1MPA0014	INSULATION SOCKET	1
8	3PA026AA	MA-101V MAIN PCB	1
7	1WAC0001	BODY FRAME (R)	1
6	1WAB0002	BODY FRAME (L)	1
5	1WF0001	SOUND ABSORBING PAD	1
4	1WSA0001	SPEAKER	1
3	1MSA0008	SCREW	4
2	1WSB0001	SPEAKER GRILLE	1
1	1WCA0001	FRONT FRAME	1

圖號 NUMBER	A101U09A	機型 MODEL	MA-101(C)(UTC571N)	品名 DESCRIPTION	爆炸圖(ASSEMBLY)	版本 VISION	MIPRO
日期 DATE	03/19/2004	比例 SCALE	1=5 A3	材質 MATERIAL			
設計 DESIGNED	JACK	繪圖 DRAWN	魏曉晴	核准 APPROVED			

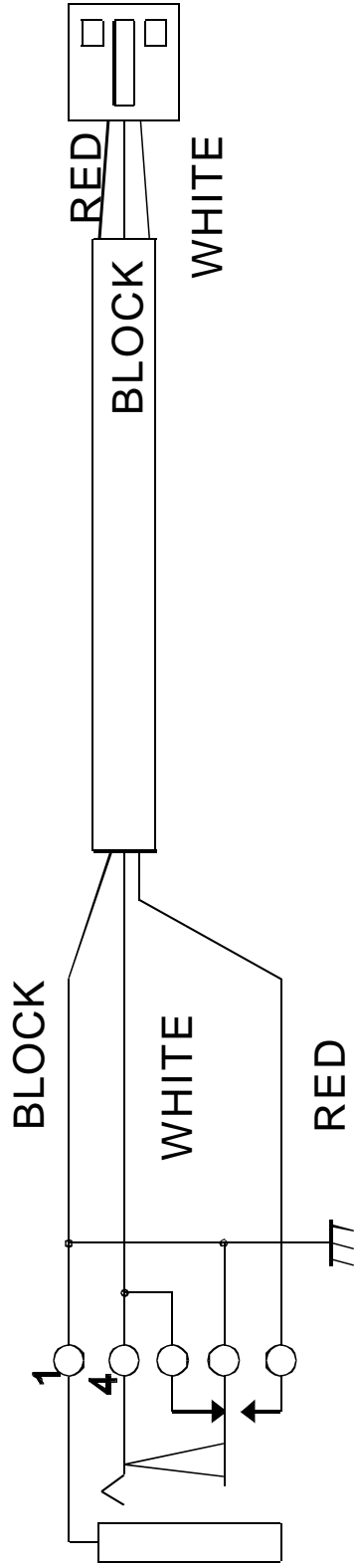

1MPA0014

YELLOW 1MLA0019



圖號 NUMBER	A101J03A	機型 MODEL	MA-101-C	品名 DESCRIPTION	(WIRING DIAGRAM)		△	△	△	MIPRO
日期 DATE	06/29/1999	比例 SCALE	A4	材料 MATERIAL			△	△	△	
設計 DESIGNED	JACK	繪圖 DRAWN	CANDY	核准 APPROVED	MICHAEL		△	△	△	
				版本 VERSION			△	△	△	

MIPRO

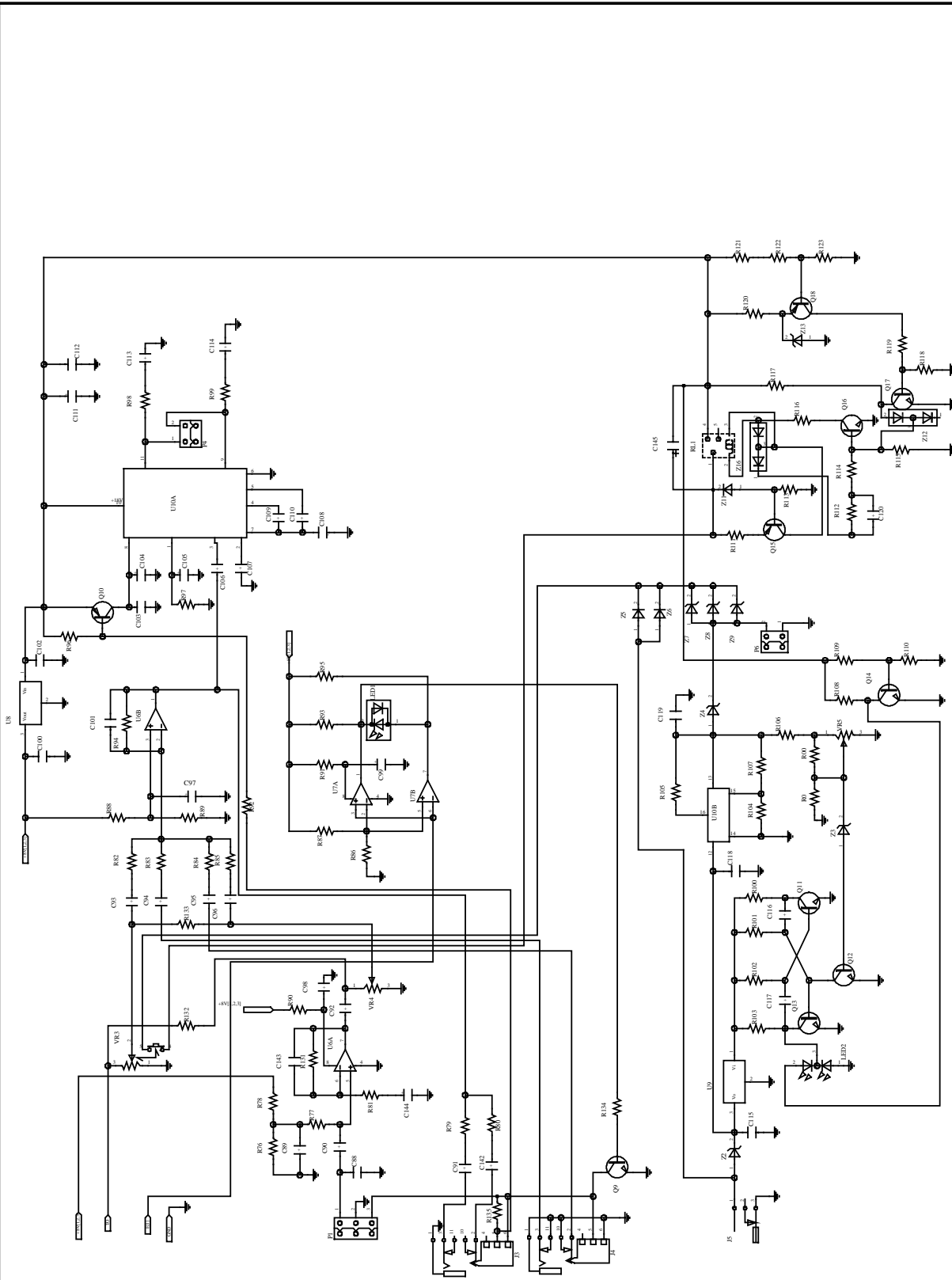

圖號 NUMBER	1CA026AA-C2	品名 DESCRIPTION	AMP CIRCUIT	版本 VISION	
日期 DATE	05/03/2004	材料 MATERIAL			
設計 DESIGNED	JACK	核准 APPROVED	MICHAEL		
模型 MODEL	MA-101/MA-101C (A026A1)	校對 DRAWN	BALL		
比例 SCALE	A4				

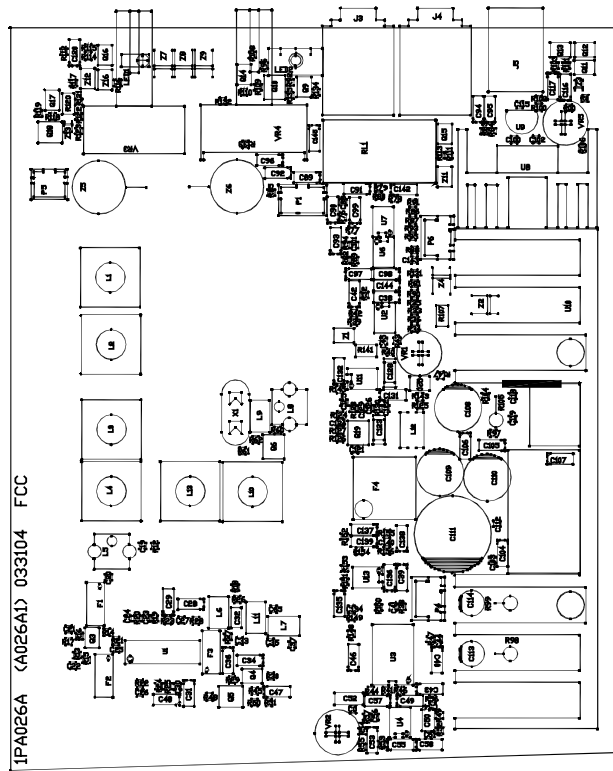
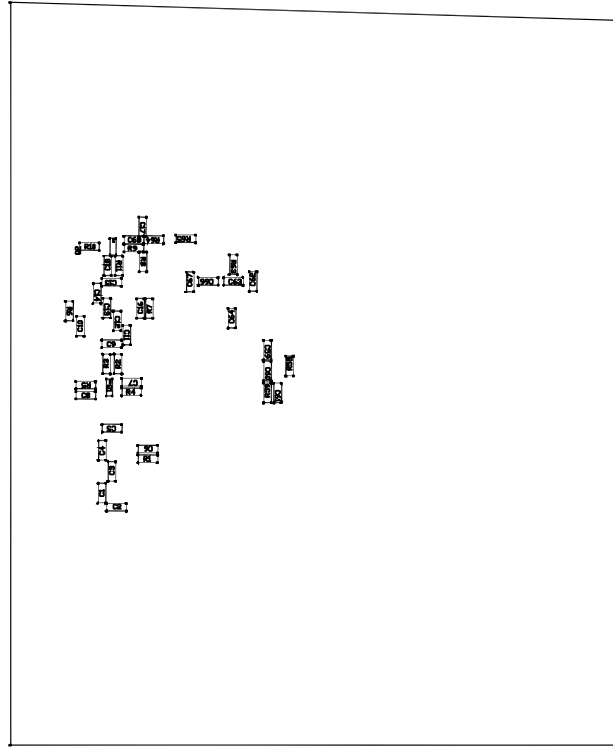

1PA026A (A026A1) 033104 FCC

圖號 NUMBER	1PA026A-F1/F2	機型 MODEL	1PA026A (A026A1)	品名 DESCRIPTION	PARTS REFERENCE		△	△	
日期 DATE	05/21/2004	比例 SCALE	A4	材質 MATERIAL			△	△	
設計 DESIGNED	JACK	繪圖 DRAWN	BALL	核准 APPROVED	MICHAEL		△	△	
				版本 VISION			△	△	

PART LIST

CIRCUIT : 1PA026A

COMPUCTOR NO.	REFETENCE	VALUE
1CCS6P101	C88	100P
1CTSAA106	C89	10uF/10V
1CTSBA225	C90	2.2uF/16V
1CTSBA225	C91	2.2uF/16V
1CTSBA225	C92	2.2uF/16V
1CTSBA225	C93	2.2uF/16V
1CTSBA225	C94	2.2uF/16V
1CTSBA225	C95	2.2uF/16V
1CTSBA225	C96	2.2uF/16V
1CTSAA106	C97	10uF/10V
1CTSAA475	C98	4.7uF/10V
1CTSAA475	C99	4.7uF/10V
1CCS6X104	C100	104P
1CCS6P068	C101	68P
1CCS6X104	C102	104P
1CCS6X103	C103	103P
1CTSBA225	C104	2.2uF/16V
1CTSBA225	C105	2.2uF/16V
1CTSDA474	C106	0.47uF/35V
1CTSDA474	C107	0.47/35V
1CENCA227	C108	220uF/25V
1CENCA107	C109	100uF/25V
1CENCA107	C110	100uF/25V
1CENCA228	C111	2200U/25V
1CCS6X104	C112	104P
1CENEA022	C113	0.22uF/50V
1CENEA022	C114	0.22uF/50V
1CCS6X104	C115	104P
1CTSAA106	C116	10uF/10V
1CTSAA106	C117	10uF/10V
1CCS6X104	C118	104P
1CCS6X104	C119	104P
1CTSBA225	C120	2.2uF/16V
1CTSBA225	C142	2.2uF/16V
1CCS6P047	C143	47P
1CTSAA106	C144	10uF/10V
1CTSDA224	C145	0.22uF/25V
1TS04097	Q9	1TS04097
1TS01179	Q10	1TS01179
1TS04097	Q11	1TS04097
1TS04097	Q12	1TS04097
1TS04097	Q13	1TS04097

A101P08A

COMPUCTOR NO.	REFETENCE	VALUE
1TS04097	Q14	1TS04097
1TS01577	Q15	1TS01577
1TS04097	Q16	1TS04097
1TS04097	Q17	1TS04097
1TS01179	Q18	1TS01179
1RS6A124	R76	120K
1RS6A332	R77	3.3K
1RS6A104	R78	100K
1RS6A222	R79	2.2K
1RS6A222	R80	2.2K
1RS6A822	R81	8.2K
1RS6A203	R82	20K
1RS6A563	R83	56K
1RS6A563	R84	56K
1RS6A563	R85	56K
1RS6A103	R86	10K
1RS6A153	R87	15K
1RS6A104	R88	100K
1RS6A104	R89	100K
1RS6A047	R90	47
1RS6A047	R91	47
1RS6A563	R92	56K
1RS6A272	R93	2.7K
1RS6A563	R94	56K
1RS6A272	R95	2.7K
1RS6A473	R96	47K
1RS6A103	R97	10K
1RNB0022	R98	2.2/0.5W
1RNB022	R99	2.2/0.5W
1RS6A102	R100	1K
1RS6A563	R101	56K
1RS6A563	R102	56K
1RS6A102	R103	1K
1RS6A222	R104	2.2K
1RNC0008	R105	0.8/1W
1RS6A243	R106	24K
1RS8D952	R107	9.53K
1RS6A152	R108	1.5K
1RS6A273	R109	27K
1RS6A182	R110	1.8K
1RS6A022	R111	22
1RS6A474	R112	470K

PART LIST

A101P08A

CIRCUIT : 1PA026A

COMPUCTOR NO.	REFETENCE	VALUE
1RS6A562	R113	5.6K
1RS6A103	R114	10K
1RS6A103	R115	10K
1RS6A022	R116	22
1RS6A153	R117	15K
1RS6A392	R118	3.9K
1RS6A622	R119	6.2K
1RS6A222	R120	2.2K
1RS6A102	R121	1K
1RS6A622	R122	6.2K
1RS6A472	R123	4.7K
1RS6A683	R131	68K
1RS6A000	R132	0
1RS6A000	R133	0
1RS6A393	R134	39K
1IS02068	U6	1IS02068
1IS02903	U7	1IS02903
1DDS0160	Z2	RB160L-40
1DDS0056	Z3	5.6V
1DDS0160	Z4	RB160L-4D
1DAN06A2	Z5	6A2
1DAN06A2	Z6	6A2
1DDS0160	Z7	RB160L-40
1DDS0160	Z8	RB160L-40
1DDS0160	Z9	RB160L-40
1DDS0204	Z11	DA204U
1DDS0204	Z12	DA204U
11DDS0047	Z13	4.7V
1DDS0204	Z16	DA204U