

KENWOOD

KOS-CV100

VIDEO BOX ▶ page 2-5

INSTRUCTION MANUAL

BOITIER VIDEO ▶ page 6-9

MODE D'EMPLOI

VIDEOBOX ▶ seite 10-13

BEDIENUNGSANLEITUNG

VIDEOBOX ▶ blz 14-17

GEBRUIKSAANWIJZING

BOX VIDEO ▶ pagina 18-21

ISTRUZIONI PER L'USO

CAJA DE VÍDEO ▶ página 22-25

MANUAL DE INSTRUCCIONES

CAIXA DE VÍDEO ▶ página 26-29

MANUAL DE INSTRUÇÕES

视频盒 ▶ 30-33页

使用说明书

비디오 상자 ▶ 34-37 페이지

조작 매뉴얼

Kenwood Corporation

Take the time to read through this instruction manual.

Familiarity with installation and operation procedures will help you obtain the best performance from your new video box.

For your records

Record the serial number, found on the back of the unit, in the spaces designated on the warranty card, and in the space provided below. Refer to the model and serial numbers whenever you call upon your Kenwood dealer for information or service on the product.

Model KOS-CV100 Serial number _____



▲ WARNING

To prevent injury or fire, take the following precautions:

- To prevent a short circuit, never put or leave any metallic objects (such as coins or metal tools) inside the unit.
- Mounting and wiring this product requires skills and experience. For safety's sake, leave the mounting and wiring work to professionals.

▲ CAUTION

To prevent damage to the machine, take the following precautions:

- Do not install the unit in a spot exposed to direct sunlight or excessive heat or humidity. Also avoid places with too much dust or the possibility of water splashing.
- Do not use your own screws. Use only the screws provided. If you use the wrong screws, you could damage the unit.

- If you experience problems during installation, consult your Kenwood dealer.
- No image other than the navigation image is displayed while the car is running.
- When this unit is connected, the mirror function of the A/V controller is not available.

Information on Disposal of Old Electrical and Electronic Equipment (applicable for EU countries that have adopted separate waste collection systems)

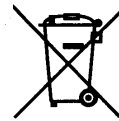

Products with the symbol (crossed-out wheeled bin) cannot be disposed as household waste.

Old electrical and electronic equipment should be recycled at a facility capable of handling these items and their waste byproducts. Contact your local authority for details in locating a recycle facility nearest to you. Proper recycling and waste disposal will help conserve resources whilst preventing detrimental effects on our health and the environment.

FCC WARNING

This equipment may generate or use radio frequency energy. Changes or modifications to this equipment may cause harmful interference unless the modifications are expressly approved in the instruction manual. The user could lose the authority to operate this equipment if an unauthorized change or modification is made.

NOTE

This Class B digital apparatus complies with Canadian ICES-003.

Accessories/ Installation Procedure

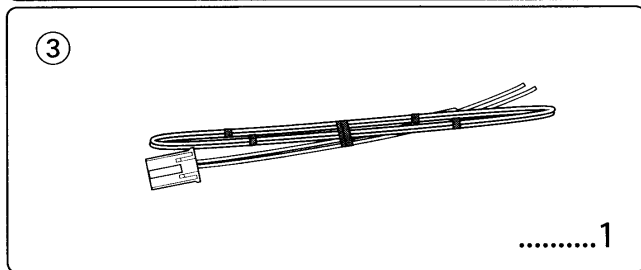
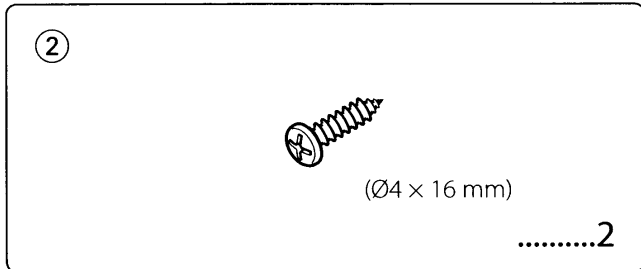
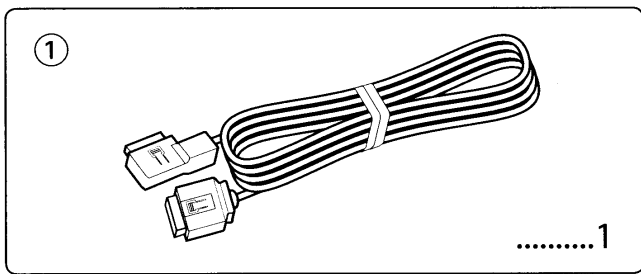

1. To prevent short circuits, remove the key from the ignition and disconnect the ⊖ terminal of the battery.
2. Make the proper input and output cable connections for each unit.
3. Install the unit in your car.
4. Reconnect the ⊖ terminal of the battery.

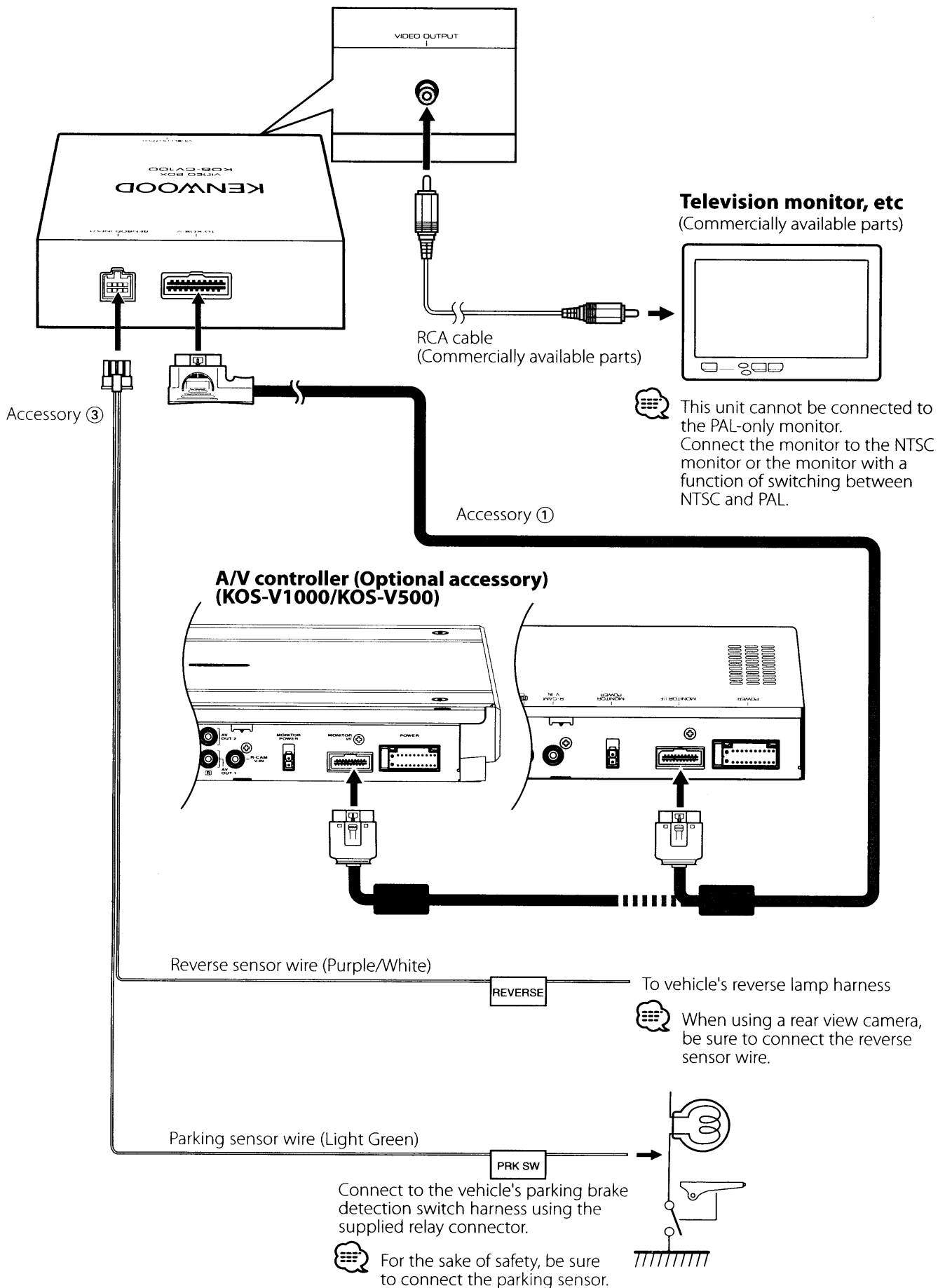

Installation

Use screws (Accessory ②) to fix Video box Unit onto an audio board or another.

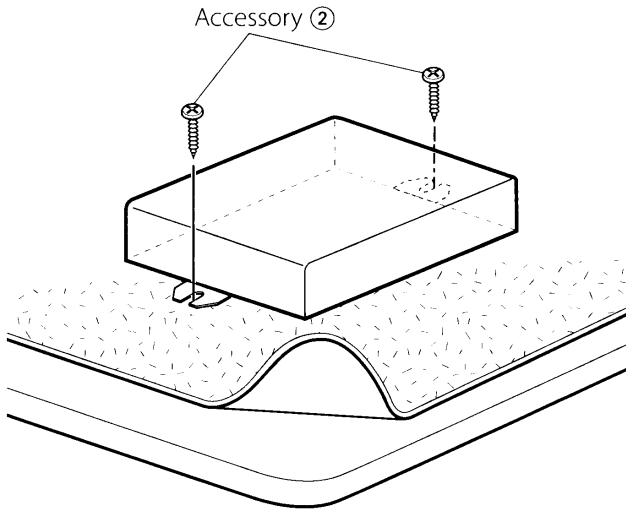

Specifications

Specifications subject to change without notice.

Video Section

Video output level (RCA jack)
: 1Vp-p/75Ω

General

Operational temperature range
: -10°C to +60°C

Storage temperature range
: -30°C to +85°C

Dimensions (W × H × D)
: 143 × 37 × 99 mm
5-5/8 × 1-7/16 × 4-7/8 inch

Weight
: 310 g (0.7 lbs)

KENWOOD

Table of Contents

	Page
U.S.A.	2
Australia	3
Canada	4,5
Military	6,7
Belgique et Grand-duché de Luxembourg	8
Danmark	9
Deutschland	9
Nederland	10
Portugal	10
UK & Ireland	11
Österreich	11
Ελλάς	12
España	12
France	13
Italia	13
Suomi	14
Andorra	14
Iceland	14
Malta	14
Norge	15
Schweiz	15
Svizzera	15
Suisse	15
Sverige	15

Dear Customer,

Thank you for purchasing this Kenwood product. As mentioned in the pages of this booklet, our warranty is only valid in the countries listed. If your country is not listed please contact your retailer for information on warranty procedure, or write to:

KENWOOD Corporation Customer Information Center
 1-16-2, Hakusan, Midori-ku,
 Yokohama-shi, Kanagawa, 226-8525 Japan



KENWOOD

Warranty Card

Geräte-Typ und Seriennummer
 Identification du produit
 Produkt navn og serie nummer
 Modelo y Número de serie
 Malli ja sarjanumero
 Μοντέλο και αριθμός σειράς
 Modello e numero di matricola
 Modell og serienummer
 Modelo e numero de série
 Apparat typ & serienummer
 Identificatie van het produkt
 Módel heiti og raðnúmer
 Il-Mudell u s-serial number
 Model number & serial number

Stempel und Unterschrift des Händlers
 Revendeur & cachet
 Forhandler
 Distribuidor y sello
 Jälleenmyyjä & leima
 Συμπράσιδα εταιρίας
 Timbro del rivenditore
 Forhandlerens navn og stempel
 Agente e carimbo
 Återförsäljare & stämpel
 Dealer & stempel
 Undirritun og stimpill söluaðila
 Timbru tal-bejjiegh
 Dealer & stamp

Kaufdatum
 Date d'achat
 Købsdato
 Fecha de compra
 Ostopäivä
 Ημερομηνία αγοράς
 Data di acquisto
 Kjøpt dato
 Data de compra
 Inköpsdatum
 Aankoopdatum
 Sölu dagur
 Id-data ta' meta nxtara
 Purchase date

Name und Anschrift des Käufers
 Nom & adresse du client
 Købers navn og adresse
 Nombre y dirección del cliente
 Asiakkään nimi & osoite
 Όνομα και διεύθυνση αγοραστή
 Nome e indirizzo del cliente
 Kundens navn og adresse
 Nome e morada do comprador
 Kundens namn & adress
 Naam & adres van de klant
 Nafn og heimilisfang kaupanda
 L-isem u l-indirizz tax-xerrej
 Name & address of customer

See back cover for table of contents.

U.S.A.

This warranty will be honored only in the U.S.A.

KENWOOD LIMITED WARRANTY FOR CAR STEREO COMPONENTS

HOW LONG IS THE WARRANTY

Kenwood U.S.A. Corporation ("Kenwood") warrants this product for a period of one (1) year from the date of original purchase.

WHAT IS COVERED AND WHAT IS NOT COVERED

Except as specified below, this warranty covers all defects in material and workmanship in Kenwood car stereo components. The following are not covered by the warranty:

1. Any product which is not distributed in the U.S.A. by Kenwood or which is not purchased in the U.S.A. from an authorized Kenwood car stereo dealer or an automobile dealer, unless the product is purchased through the U.S.A Military Exchange Service.
2. Any product on which the serial number has been defaced, modified or removed.
3. Damage, deterioration or malfunction resulting from:
 - a. Any shipment of the product (claims must be presented to the carrier).
 - b. Installation or removal of the product.
 - c. Accident, acts of nature, misuse, abuse, neglect, unauthorized product modification or failure to follow instructions supplied with the product.
 - d. Repair or attempted repair by anyone not authorized by Kenwood.
 - e. Any other cause which does not relate to a product defect.

WHO IS PROTECTED

This warranty is enforceable only by the original purchaser.

WHAT WE WILL PAY FOR

We will pay for all labor and material expenses for covered items. Payment of shipping charges is discussed in the next section of this warranty.

HOW TO OBTAIN WARRANTY SERVICE

If your KENWOOD product ever needs service:

1. Take or ship it to any KENWOOD Authorized Service Center in the U.S.A. along with & complete description of the problem. (if you are uncertain as to whether a Service Center is authorized, please call **1-800-KENWOOD** for the nearest Service Center. **1-800-536-9663**).
2. Although you must pay any shipping charges if it is necessary to ship the product for warranty service, we will pay the return shipping charges if the repairs are covered by the warranty within the United States.
3. Whenever your units are taken or sent for warranty service, you must include a copy of the original dated sales receipt as proof of warranty coverage.

LIMITATION OF IMPLIED WARRANTIES

ALL IMPLIED WARRANTIES, INCLUDING WARRANTIES OF MERCHANTABILITY AND FITNESS FOR A PARTICULAR PURPOSE, ARE LIMITED IN DURATION TO THE LENGTH OF THIS WARRANTY.

EXCLUSION OF DAMAGES

KENWOOD'S LIABILITY FOR ANY DEFECTIVE PRODUCT IS LIMITED TO THE REPAIR OR REPLACEMENT OF THE PRODUCT AT OUR OPTION. KENWOOD SHALL NOT BE LIABLE FOR:

1. INSTALLATION OR REMOVAL CHARGES, DAMAGE TO OTHER PROPERTY CAUSED BY ANY DEFECTS IN KENWOOD CAR STEREO COMPONENTS, DAMAGES BASED UPON INCONVENIENCE, LOSS OF USE OF THE PRODUCT; OR
2. ANY OTHER DAMAGES, WHETHER INCIDENTAL, CONSEQUENTIAL OR OTHERWISE.

SOME STATES DO NOT ALLOW LIMITATIONS ON HOW LONG AN IMPLIED WARRANTY LASTS AND/OR DO NOT ALLOW THE EXCLUSION OR LIMITATION OF INCIDENTAL OR CONSEQUENTIAL DAMAGES, SO THE ABOVE LIMITATIONS AND EXCLUSIONS MAY NOT APPLY TO YOU.

This warranty gives you specific legal rights, and you may also have other rights which vary from state to state.

If a problem develops during or after the Limited Warranty Period, or if you have any questions regarding the operation of the product, you should contact your KENWOOD Authorized Dealer or Authorized Service Center. If the problem or your question is not handled to your satisfaction, please contact our Customer Relations Department at the address listed below:

KENWOOD USA CORPORATION
P.O. Box 22745, 2201 East Dominguez Street, Long Beach, CA 90801-5745
Tel. (310) 639-5300

AUSTRALIA

The warranty will only be honoured in the country in which the unit was originally purchased.

EXPRESS WARRANTY STATEMENT FOR CAR STEREO AND PERSONAL AUDIO COMPONENTS

KENWOOD ELECTRONICS AUSTRALIA PTY. LTD. is proud of the quality and workmanship of its audio equipment. This unit has been properly designed, tested and inspected before it was shipped to you. If properly installed and operated in accordance with instructions furnished, it should give optimum reliable performance.

SCOPE OF EXPRESS WARRANTY

Each of the KENWOOD brand products is expressly warranted under normal installation and use against defects in material and workmanship. During the express warranty period, KENWOOD ELECTRONICS AUSTRALIA PTY. LTD. will provide to any KENWOOD Authorised Service Centre in Australia free of charge both parts and labour necessary to correct any defect in material or workmanship. However, the exclusions noted under the heading "CONDITIONS OF THE EXPRESS WARRANTY" are not covered by this express warranty.

EXPRESS WARRANTY PERIOD

The KENWOOD brand car stereo and personal audio components are expressly warranted for a period of **ONE YEAR** from the date of the original purchase.

CONDITIONS OF THE EXPRESS WARRANTY

When requesting service under KENWOOD express warranty record, together with a valid purchase docket must be presented to an authorised KENWOOD Service Centre with your equipment.

The following are not covered by this express warranty:

1. Voltage conversions.
2. Cabinets, grilles, other exterior finishes, belts, tape heads, and other non-durable parts and accessories.
3. Any fault caused by faulty installation, water damage, the vehicle (including its electrical system) or connection to an incorrect power supply.
4. Periodic check-ups which do not disclose any defects covered by the warranty.
5. Units on which the serial number has been defaced, modified or removed.
6. Damage or deterioration:
 - a. Resulting from installation and/or removal of the product.
 - b. Resulting from accident, misuse, abuse, neglect, unauthorised product modification or failure to follow instructions contained in the Owner's Manual.
 - c. Resulting from repair by anyone not authorised by KENWOOD.
 - d. Resulting from installation of parts or accessories that do not conform to the quality or specifications of the original parts or accessories.
 - e. Occurring during shipment (claims must be presented to shipper).
7. Damaged magnetic tapes.
8. Installation and removal charges are not covered.
9. This express warranty excludes shipping or delivery charges to or from an authorised KENWOOD Service Centre.
10. The benefits conferred by this express warranty are in addition to all other rights and remedies in respect of the product which the consumer has under the Trade Practices Act and/or other State or Territory Laws.

EXCLUSION OF CERTAIN DAMAGES

KENWOOD's liability for any defective product is limited to the repair or replacement of said product at our option, and shall not include damages of any kind, whether incidental, consequential or otherwise.

PROCEDURE WHEN REQUESTING SERVICE UNDER THE WARRANTY

1. Make your equipment available, with this warranty record and purchase docket attached, to the dealer from whom you made the purchase, or the nearest authorised KENWOOD Service Centre, or ship your equipment in its original packaging, or equivalent, fully insured and shipping charges pre-paid, to the authorised KENWOOD Service Centre.
2. Attach detailed description of the problem encountered, including details of any interconnections made to associated equipment.
3. Make sure you recover this card, your purchase docket and repair docket when accepting the equipment back after repair.

IMPORTANT NOTICE

1. Proper maintenance and use are important to the performance level of all KENWOOD brand products. Therefore, you should read your instruction manual.
2. Retain your purchase docket together with this warranty record in a safe place, and present them both to prove your eligibility for warranty work.
3. We recommend that you keep all the original packaging as it provides the best protection you can have for transportation of your equipment in the future.
4. Location of nearest KENWOOD Service Centre will be sent upon request.
5. This warranty is in addition to and not in place of such rights as the owner may have at law.

KENWOOD ELECTRONICS AUSTRALIA PTY. LTD.
16 GIFFNOCK AVENUE, CENTRECOURT ESTATE, NORTH RYDE,
N.S.W. 2113, AUSTRALIA
TEL. (02) 8879-2222

GARANTIE KENWOOD

KENWOOD ELECTRONICS CANADA INC. (ci-après appelée "KENWOOD"), donne par écrit la garantie suivante à l'acheteur original de chaque nouveau produit Kenwood distribué au Canada par KENWOOD et acheté à un concessionnaire autorisé par KENWOOD.

KENWOOD garantit, sous réserve des termes et des conditions énoncés ci-dessous, que chaque nouveau produit Kenwood, dans des conditions d'emploi normales, est exempt de tous défauts. Si l'un d'eux se produit pendant la période de garantie, KENWOOD s'engage à assumer le coût des pièces défectueuses et de la main-d'œuvre nécessaires pour effectuer les réparations pourvu que de tels défauts sont attribuables à des pièces défectueuses employées lors de la fabrication du produit Kenwood ou à la main-d'œuvre tel qu'établi par KENWOOD ou par l'un de ses centres de service autorisés. Appelez KENWOOD pour vérifier si un concessionnaire ou un centre de service est autorisé par KENWOOD.

PÉRIODE DE GARANTIE

Les pièces et la main-d'œuvre nécessaires pour la réparation des produits Kenwood sont garanties pendant la période d'un (1) an à compter de la date d'achat, de bail ou de location originale, sauf dans les cas où les produits Kenwood sont employés dans un but professionnel ou commercial, où la garantie des pièces et de la main-d'œuvre demeure en vigueur pendant une période de quatre-vingt-dix (90) jours sous réserve des termes et des conditions de la garantie.

EXCLUSIONS DE GARANTIE

Cette garantie ne couvre pas:

- les produits achetés à l'étranger ou achetés au Canada et transportés à l'étranger;
- les produits achetés à un concessionnaire non autorisé par KENWOOD;
- les produits dont le numéro de série manque, a été effacé ou modifié;
- les services d'entretien périodiques qui n'indiquent aucun défaut couvert par cette garantie;
- les défauts causés par les désastres, les accidents, les abus, les emplois incorrects, les éclairés, les surtensions de courant, les manques de soins ou d'entretiens périodiques, les modifications non autorisées ou les manques de respect du mode d'emploi;
- les défauts ou les dommages causés lors de réparations effectuées par une personne ou par une partie non autorisée par KENWOOD;
- les défauts causés par l'emploi de pièces ou de dispositifs qui ne se conforment pas aux exigences de KENWOOD;
- les finitions extérieures, les pièces cosmétiques, les têtes de bandes, les adaptateurs, les antennes, les câbles, les bandes, les disques endommagés ou dépeints, ni les défauts ou dommages causés par des piles défectueuses ou qui fuient;
- les défauts ou dommages qui se produisent pendant l'expédition des produits Kenwood (On devrait déposer de telles réclamations auprès des compagnies de transport);
- les conversions de tension et/ou de fréquence du produit;
- les frais d'installation ou d'enlèvement du produit.

COMMENT OBTENIR DU SERVICE SOUS GARANTIE

Au cas où un service sous garantie de votre produit Kenwood s'avère nécessaire, veuillez livrer le produit à n'importe quel centre de service KENWOOD et présenter la copie originale du contrat de vente et cette carte de garantie en tant que preuve de garantie ou veuillez faire parvenir votre produit assuré et port payé au centre de service KENWOOD autorisé le plus proche. Pour éviter toutes possibilités de dommages pendant le transport, veuillez bien emballer le produit. Veuillez inclure une copie du contrat de vente original et cette carte de garantie en tant que preuve de garantie aussi bien que votre nom, numéros de téléphone au poste de travail et/ou au domicile, votre adresse et une description détaillée des défauts. Les produits sous garantie réparés seront retournés port payé aux destinations à l'intérieur du Canada. Le consommateur sera responsable de tous frais de transport et d'autres frais qui s'y rapportent pour faire expédier les produits à destinations à l'extérieur du Canada.

L'ENTIERE GARANTIE

Cette garantie représente l'entière garantie donnée par écrit par KENWOOD. KENWOOD ne se tient aucunement responsable de toutes extensions ni de toutes augmentations de cette garantie faites ou entreprises par toutes personnes, parties, concessionnaires ou centres de service ou par leurs agents ou employés au nom de KENWOOD au moyen d'affirmations verbales ou écrites, d'annonces ou de promotions, y inclus tous programmes ou plans de garantie étendue que puissent offrir les concessionnaires ou les centres de service, à moins que KENWOOD n'y ait consenti par écrit d'avance.

RENONCIATION

KENWOOD renonce à toutes responsabilités de perte de temps, d'emploi du produit, de tous dommages indirects ou accessoires causés à d'autres produits ou biens, de tous inconvénients ou de toutes pertes commerciales.

AVIS AUX CONSOMMATEURS

Les stipulations contenues dans la présente garantie écrite n'ont pas pour but de limiter, de modifier, de diminuer, de rejeter ni d'exclure d'autres garanties ni droits énoncés dans n'importe quelles lois ou législations provinciales ou fédérales.

IMPORTANT

KENWOOD ne considère pas cette garantie toute seule comme étant une preuve d'achat valide. Lorsqu'on demande du service sous garantie, il faudra présenter la copie originale du contrat de vente aussi bien que cette carte de garantie en tant que preuve de garantie. On recommande de les conserver dans un lieu sûr au cas où elles s'avèreraient nécessaires à l'avenir.

KENWOOD ELECTRONICS CANADA INC.
6070 Kestrel Road, Mississauga, Ontario, Canada L5T 1S8
Téléphone: (905) 670-7211
Télécopieur: (905) 670-7248

4

KENWOOD WARRANTY

KENWOOD ELECTRONICS CANADA INC. (hereinafter called "KENWOOD"), gives the following written warranty to the original customer of each new Kenwood product distributed in Canada by KENWOOD and purchased from a dealer authorized by KENWOOD.

KENWOOD warrants that each new Kenwood product, under normal use, is free from any defects, subject to the terms and conditions set forth below. If a defect should occur within the warranty period, repairs will be made free of charge for parts and labour when such defects are determined by KENWOOD or its authorized service centres to be attributable to faulty materials or workmanship at time of manufacture. Please contact KENWOOD to confirm if a dealer or service centre is authorized by KENWOOD.

WARRANTY PERIOD

This Kenwood product is warranted for parts and labour for a period of one (1) year from the date of original purchase, lease or rental, except for products which are used in a professional or commercial application, which are warranted for a period of ninety (90) days for parts and labour and are subject to the terms and conditions of the warranty.

WARRANTY EXCLUSIONS

This warranty excludes:

- Products purchased in a foreign country or purchased in Canada and taken to a foreign country.
- Products purchased from a dealer not authorized by KENWOOD.
- Products with the serial number defaced, altered or missing.
- Periodic check-ups which do not disclose any defects covered by this warranty.
- Defects resulting from disaster, accident, abuse, misuse, lightning, power surges, neglect or lack of periodic maintenance, unauthorized modification or failure to follow instructions in the owner's manual.
- Defects or damage as a result of repairs performed by a person or party not authorized by KENWOOD.
- Defects resulting from the use of parts or devices that do not conform to KENWOOD specifications.
- Damage or deterioration occurring to any exterior finishes, cosmetic parts, tape heads, adaptors, antennas, cables, tapes, discs or faults or damage caused by defective or leaking batteries.
- Defects or damage occurring during shipping (claims should be presented to the shipping company).
- Product voltage and /or line frequency conversions.
- Product installation or removal charges.

TO OBTAIN WARRANTY SERVICE

Should your Kenwood product require warranty service, deliver it to any authorized KENWOOD service centre and present the original copy of your bill of sale and this warranty card as proof of warranty, or send your product fully insured and freight prepaid to the nearest authorized KENWOOD service centre. To avoid possible shipping damage, make sure the product is properly packed. Include a copy of your original bill of sale and this warranty card as proof of warranty along with your name, home and /or work telephone number(s), a complete return address and a detailed description of the fault(s). Products repaired within warranty will be returned freight prepaid to destinations within Canada. The customer is responsible for all freight and related costs for the return of products to destinations outside Canada.

ENTIRE WARRANTY

This warranty constitutes the entire written warranty given by KENWOOD. No person, party, dealer or service centre or their agents or employees are authorized to extend or enlarge this warranty on behalf of KENWOOD by any written or verbal statement or advertisement or promotion, including any extended warranty program or plan that may be offered by the dealer or service centre, unless approved in writing by KENWOOD.

DISCLAIMER

KENWOOD disclaims any responsibility for loss of time or use of the product or any other indirect, incidental or consequential damage to other products or goods, inconvenience or commercial loss.

NOTICE TO CONSUMER

The provisions contained in this written warranty are not intended to limit, modify, take away, disclaim or exclude any warranties or rights you may have which are set forth in any applicable provincial or federal laws or legislation.

IMPORTANT

This warranty card by itself is not considered by KENWOOD as a valid proof of purchase. When applying for warranty repairs, you must present the original copy of your bill of sale and this warranty card as proof of warranty, so we recommend that they be kept in a safe place, should they be required in the future.

KENWOOD ELECTRONICS CANADA INC.
6070 Kestrel Road, Mississauga, Ontario, Canada L5T 1S8
Tel.: (905) 670-7211
Fax: (905) 670-7248

5

MILITARY

Units purchased through the U.S.A. military exchange service overseas may be serviced under warranty in the continental U.S.A., subject to the following conditions.

- The original warranty is in effect.
- Proof of purchase is provided to the servicer.

WARRANTY FOR MILITARY MARKET

KENWOOD CORPORATION is proud of the quality and workmanship of its audio equipment. This unit has been properly designed, tested and inspected before it was shipped to you. If properly installed and operated in accordance with instructions furnished, it should give you an optimum reliable performance.

WARRANTY PERIOD

This product is warranted for a period of **ONE YEAR** from the date of the original purchase.

SCOPE OF WARRANTY

Except as specified below, this warranty covers all defects in materials and workmanship of the KENWOOD brand products.

During the warranty period, any authorized KENWOOD Service Center in the military market listed in the back of this warranty card will provide you free-of-charge both parts and labor required to correct any defect in materials or workmanship.

The following are not covered by this warranty.

- Voltage conversions.
- Periodic check-ups which do not disclose any defect covered by the warranty.
- Cabinets, grilles, other exterior finishes, belts, tape heads, and other non-durable parts and accessories.
- Units on which the serial number has been effaced, modified or removed.
- Installation and/or removal charges.
- Damaged magnetic tapes.
- House call charges for any repairs.
- Shipping or delivery charges to or from an authorized KENWOOD Service Center.
- This warranty will not cover any failure that is due to any of the following conditions in accordance with the visual inspection of the authorized KENWOOD Service Center:
 - Improper maintenance or repair, including the installation of parts or accessories that do not conform to the quality and specifications of the original parts.
 - Misuse, abuse, neglect, unauthorized product modification or failure to follow instructions contained in the Owner's Manual.
 - Accidental or intentional damages.
 - Repairs or attempted repairs by an unauthorized agency. (All repairs must be performed at an authorized KENWOOD Service Center.)
 - Damages or deteriorations caused during shipment (Claims must be presented to the carrier).
 - Damages or deteriorations resulting from removal and/or replacement.

PURCHASER'S RESPONSIBILITIES

As the purchaser of a new KENWOOD brand product, you are requested to do the following in order to obtain KENWOOD warranty service.

- Retain your sales slip or other evidence of purchase for proving your eligibility for requesting KENWOOD warranty service.
- Make your unit available to an authorized KENWOOD Service Center in the military market for inspection and approved warranty service, or ship your unit in its original carton box or equivalent, fully insured and shipping charges prepaid, to the authorized KENWOOD Service Center.

LIMITATION OF IMPLIED WARRANTIES

Any and all implied warranties, including warranties of merchantability and fitness for a particular purpose, shall be limited in duration to the length of this warranty.

EXCLUSION OF CERTAIN DAMAGES

KENWOOD's liability for any defective product is limited to the repair or replacement of said product, at our option, and shall not include damages of any kind, whether incidental, consequential or otherwise, except to the extent prohibited by applicable law.

6

KENWOOD AUTHORIZED SERVICE CENTERS IN MILITARY MARKET

JAPAN:

Yokota

Kenwood Rep.; c/o
Yokota BX, JAAX AAFES-PAC,
APO San Francisco 96328

Zama

Kenwood Rep.; c/o
Zama PX, JAAX AAFES-PAC,
APO San Francisco 96343

Misawa

Kenwood Rep.; c/o
Misawa BX, JAAX AAFES-PAC,
APO San Francisco 96519

Yokosuka

Kenwood Rep.; c/o
A-33, Yokosuka NEX No. 260-010
FPO Seattle 98760

Atsugi

Kenwood Rep.; c/o
Atsugi NEX No. 260-020 FPO Seattle 98767

Iwakuni

Kenwood Rep.; c/o
Marine Corps Exchange, Marine Corps Air Station,
FPO Seattle 98764

Sasebo

Sasebo NEX;
Navy Exchange 260-040
F.A. Box 115 FPO Seattle 98766

Okinawa

Kenwood Rep.; c/o
OWAX, AAFES-PAC, APO San Francisco 96230

KOREA:

Kenwood Rep.; c/o
KOAX Repair Shop, AAFES-PAC
DD-Camp Market, APO San Francisco 96488

GUAM:

Kenwood Rep.; c/o
Guam NEX No. 230-010,
FPO San Francisco 96630
Kenwood Rep.; c/o
GUAX, AAFES-PAC, APO San Francisco 96334

U.S.A.:

Hawaii

Kenwood Factory Service
99-994 Iwaena St., Aiea, Hawaii 96701

Alaska

Vista Radio TV;
861 East Loop Road, Anchorage, Alaska 99501
Anchorage Commercial Electronics, Inc.;
1450 East 9th Ave., Anchorage, Alaska 99501

In The Continental U.S.A.

For Nearest Authorized Service Center;
Tel: 1-800-536-9663

Kenwood Service U.S.A.

Kenwood Factory Service;
P.O. Box 22745, 2201 East Dominguez Street,
Long Beach, California 90801-5745
Tel: (310) 639-5300

EUROPE:

Please inquire at the military resale outlets where you bought your Kenwood products, or
KENWOOD ELECTRONICS DEUTSCHLAND GMBH:
Rembrücker-Str. 15, 63150 Heusenstamm, Germany
Tel.: 49-06104-69010

7

Nederland

KENWOOD ELECTRONICS EUROPE B.V.

Gaachte gebruiker van Kenwood producten. Wij danken U voor het kiezen van dit Kenwood product (het "Product").

- (b) Het aankoopbewijs of elk ander document waarvoor de datum van aankoop bij een detailhandelaar gevraagd is... (c) De volledige naam en het adres van de detailhandelaar bij wie het Product werd aangekocht... (d) Het Serienummer en de naam van het model van het Product...

Kenwood Electronics Europe B.V. Amsterdamsing 37, 1422 AC Uithoorn Tel. 0297-519900 www.kenwood.com

- (e) Het Product wordt vervoerd in overeenstemming met alle nationale of lokale wetten en veiligheidsvoorschriften... (f) De garantie wordt voortgezet in het land van de gebruiker... (g) Het Product wordt vervoerd in overeenstemming met alle nationale of lokale wetten...

Portugal

H. F. GONCALVES, LDA.

Cada utilizador dos produtos Kenwood Óbrigado por ter escolhido este produto Kenwood (abaixo simplesmente designado por "Produto").

- (b) Antes do Produto causar danos ou reparações inadequadas no importador... (c) Não pode ser utilizada para outros fins... (d) Não pode ser utilizado para outros fins...

H. F. GONCALVES, LDA. Montijo - Portugal Tel. +351-212891147 www.kenwood.pt

- (e) Não pode ser utilizado para outros fins... (f) Não pode ser utilizado para outros fins... (g) Não pode ser utilizado para outros fins...

Suomi

KENWOOD ELECTRONICS EUROPE B.V.

Kenwood tuotteiden käyttäjille. Kiitos siitä, että olet valinnut tämän Kenwood tuotteen (jäljempänä "tuote").

- (b) Etä olet valinnut tämän valmistajan tuotteen... (c) Etä olet valinnut tämän valmistajan tuotteen... (d) Etä olet valinnut tämän valmistajan tuotteen...

Kenwood Electronics Europe B.V. Amsterdamsing 37, 1422 AC Uithoorn Tel. 0297-519900 www.kenwood.com

- (e) Etä olet valinnut tämän valmistajan tuotteen... (f) Etä olet valinnut tämän valmistajan tuotteen... (g) Etä olet valinnut tämän valmistajan tuotteen...

Andorra

Iceland

Estimado Usuario de los productos Kenwood. Gracias por haber elegido este Producto Kenwood.

Kæri notandi Kenwood tækja. Til hamingu með nýja Kenwood tækibútt. Eit einhverjg framleiðslugættir komu í ljós...

Malta

Suisse

Kenwood IBERICA, S.A. Tel. +34-93-507-5252 www.kenwood.es

TAKTUR-O. HARALDSSON H.F.

Ábyrgðartími er eitt frá kaupdægum að teiga Kaupdagi skal flytja tækibútt. Að öðru leyti skal viðgætt á framleiðslugættum farga frá kaupdagi...

CUTAJAR LTD.

Sverige

Österreich

UK & Ireland

KENWOOD ELECTRONICS EUROPE B.V.

Dear User of Kenwood Products. Thank you for having chosen this Kenwood product (the "Product").

- (c) The full name and address of the retailer from whom the Product was purchased... (d) The Serial Number and Model name of the Product...

Kenwood Electronics UK Ltd. Kenwood House, Dwight Road, Watford, Herts, WD18 5SE Tel. 01923-816444 www.kenwood.co.uk

Swizzera

Delen's Elektronisk Service a/s

KENWOOD ELECTRONICS GMBH

Gentile cliente, la ringraziamo per aver acquistato questo prodotto KENWOOD.

Reinbrecker Str. 15 D-63150 Heusenstamm Tel. 049-5104-6901-0 www.kenwood.de

Bild & LjudeServise

UK & Ireland

KENWOOD ELECTRONICS UK LTD.

Thank you for having chosen this Kenwood product (the "Product"). It becomes defective under normal operating conditions...

- (c) The full name and address of the retailer from whom the Product was purchased... (d) The Serial Number and Model name of the Product...

Kenwood Electronics UK Ltd. Kenwood House, Dwight Road, Watford, Herts, WD18 5SE Tel. 01923-816444 www.kenwood.co.uk

- (e) If the Product is used in a European country where it is subject to other standards and requirements than those applicable in the country of first sale by the manufacturer... (f) Subject as mentioned above, the Product will be repaired or replaced free of charge...

Österreich

KENWOOD ELECTRONICS GMBH

Sehr geehrter Kunde, wir danken Ihnen für den Kauf dieses Kenwood-Produkts. Sollte dieses Produkt unter normalen Betriebsbedingungen... (b) Der vollständige Name und die Anschrift des Einzelhändlers...

- (c) Schäden durch Nachlässigkeit, Unfälle, Änderungen, unsachgemäße Montage, mangelhafte Verpackung... (d) Verbräuche und Verschleissteile, die im Rahmen des normalen Kundendienstes auszuwechseln sind...

Kenwood Elektronisk Service a/s Reinbrecker Str. 15 D-63150 Heusenstamm Tel. 049-5104-6901-0 www.kenwood.de

- (e) Wenn das Produkt in einem Land benutzt wird, für das dieses nicht konzipiert wurde... (f) Schäden an Produkt, die durch mangelhafte oder nicht fachgerechte Arbeiten entstanden sind...