



KENWOOD
HI/FI STEREO COMPONENTS

SERVICE MANUAL

**KD-3070
(KD-3077)**



STEREO TURNTABLE

EXTERNAL VIEW

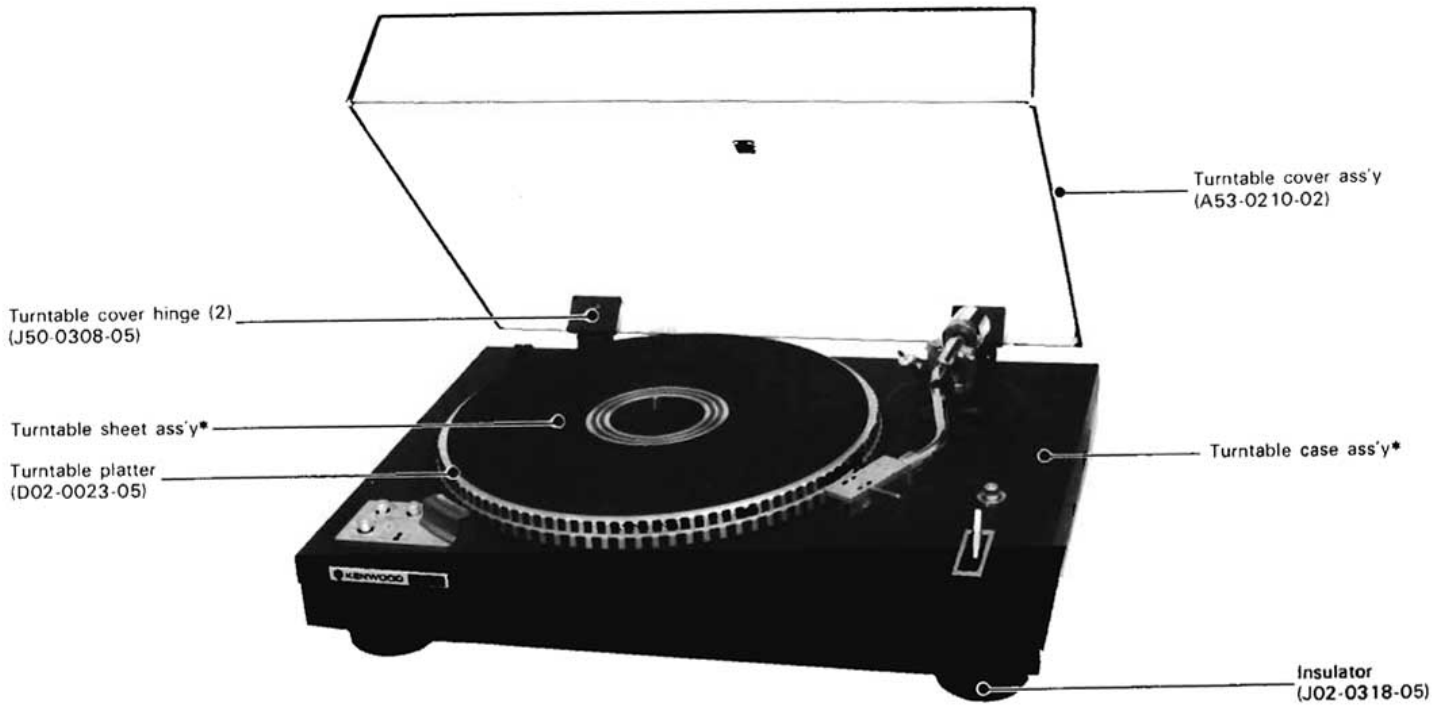

When returning play lever, push the cut button.



Refer to Descriptions Parts List

INTERNAL VIEW

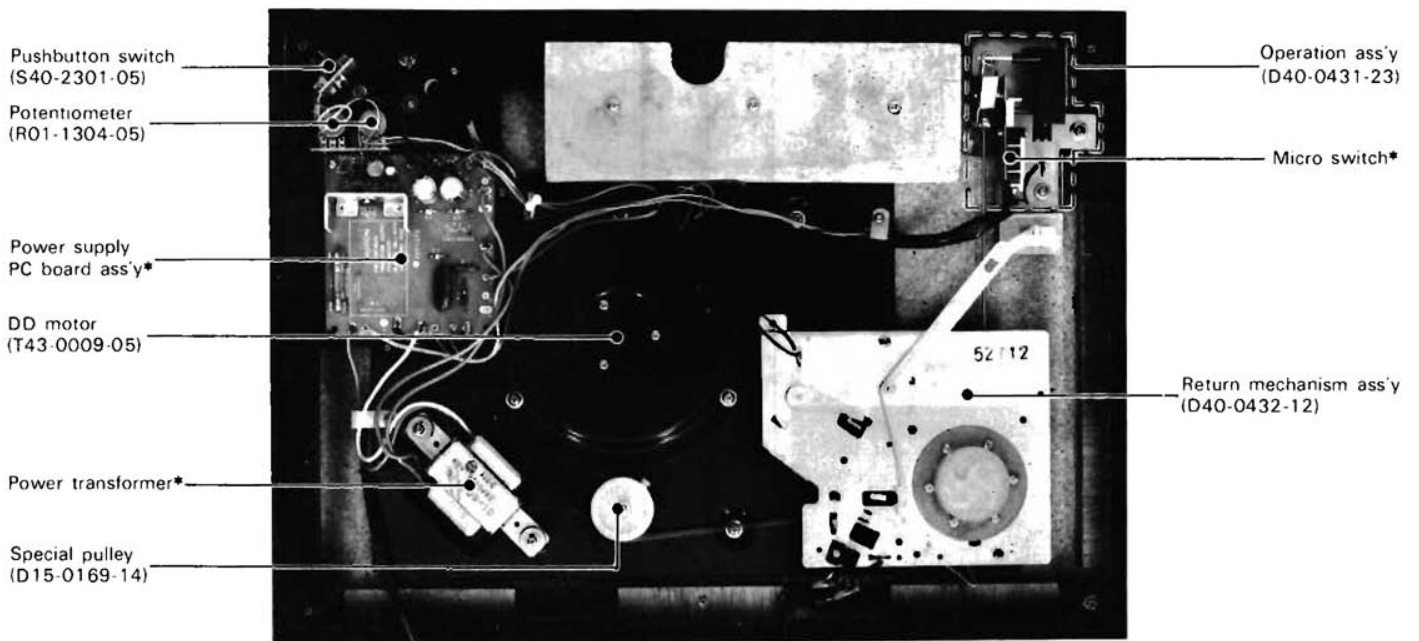
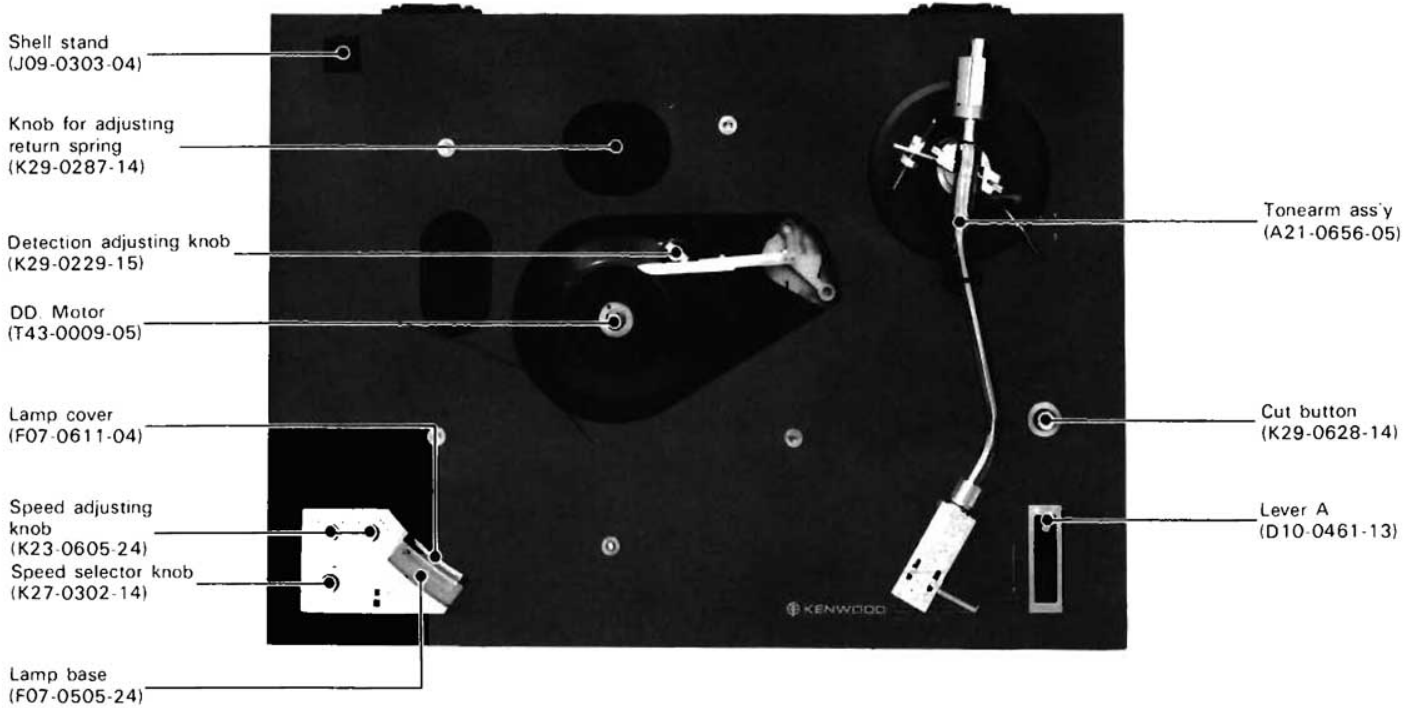

* Refer to Destinations' Parts List.

DISASSEMBLY



BOTTOM CASE

When separating the bottom case from the turntable case, remove the screws fixed the bottom case from the bottom side and the hinge holder from rear side.

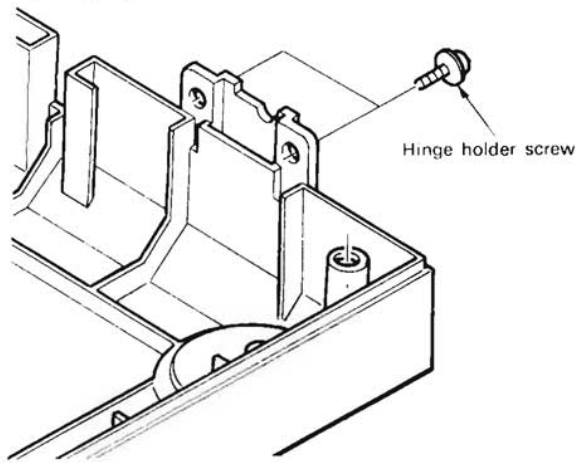

MOTOR

Remove the 3 screws from the bottom side.

Motor mounting screw

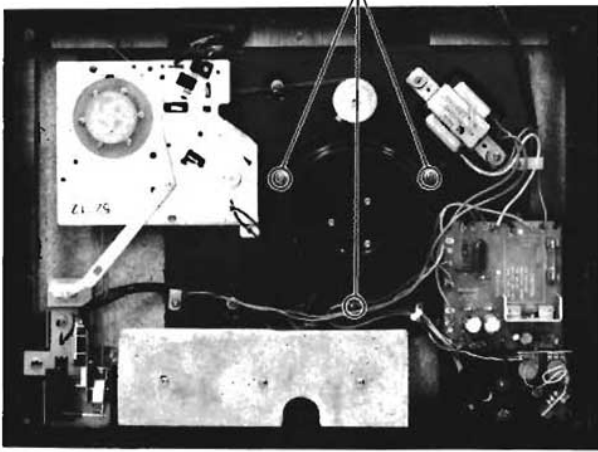

OPERATION ASS'Y

Disengage the operation rod and remove the cam from the cut lever, then remove the 3 screws holding the operation ass'y.

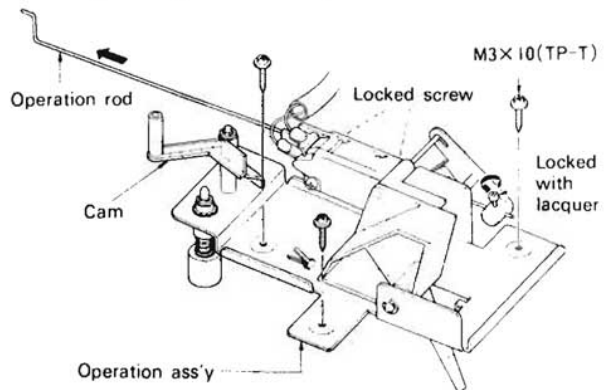

Note: See page 6 for mounting.

CUT BUTTON/CAM

Remove E rings from the bottom side.

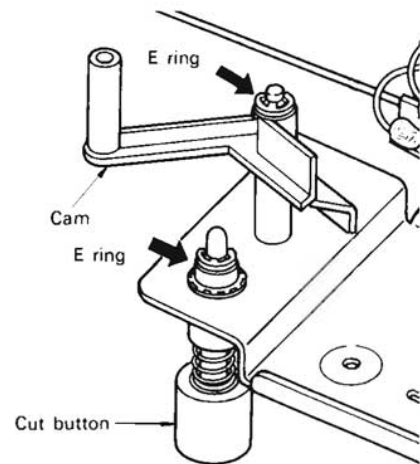

PUSHBUTTON/POTENTIOMETER

Both the pushbutton switch and potentiometer are fixed to the barrier. Take out the barrier by removing the screws from the turntable case.

Barrier mounting screw

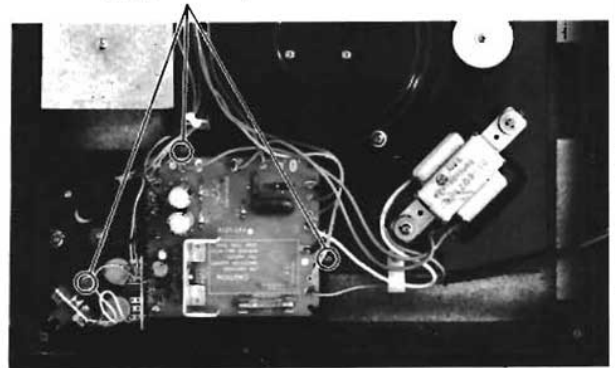

DISASSEMBLY

RETURN ARM ASS'Y

The return arm is fixed by 2 set screws.

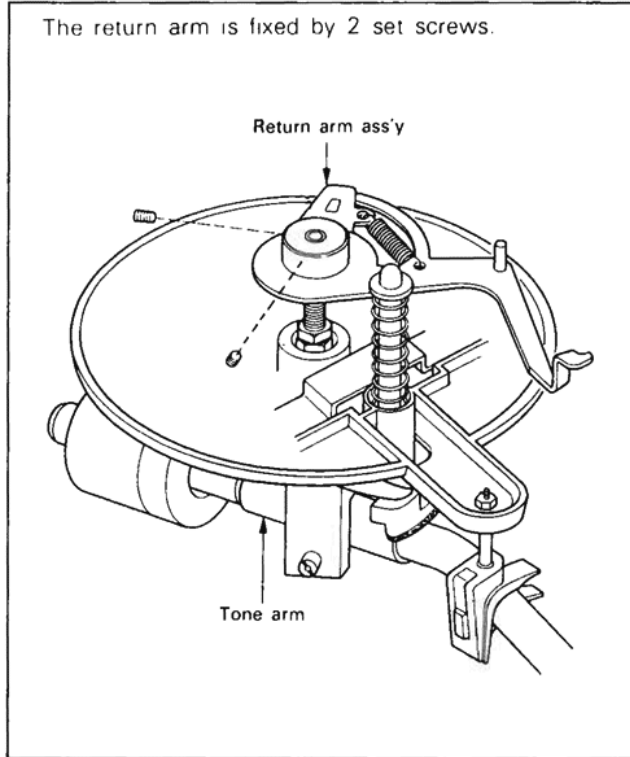

Note: See page 6 for mounting

PAUSE CAM

The pause cam is supported by the pause cam bracket which is fixed by 2 screws.

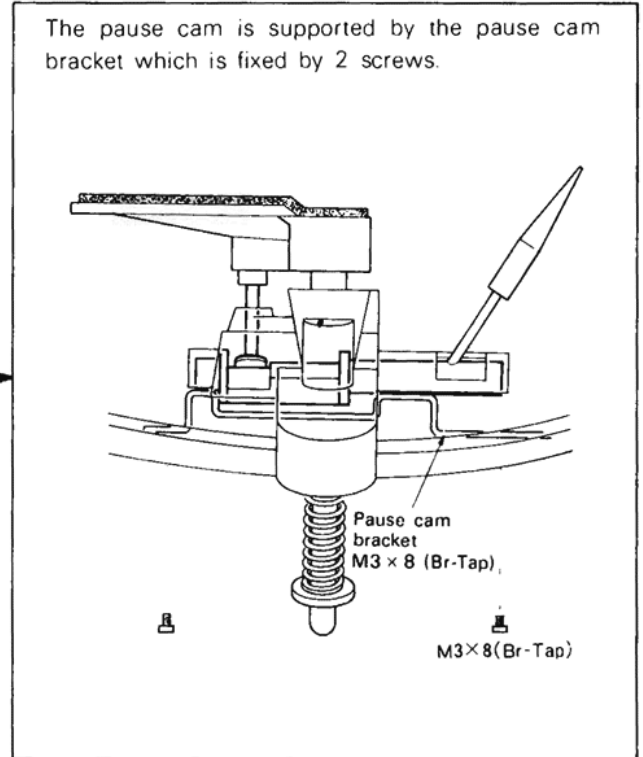

RETURN MECHANISM ASS'Y

Disengage the operation rod and remove the cam from the cut lever. Next, remove the 3 screws holding the return mechanism ass'y.

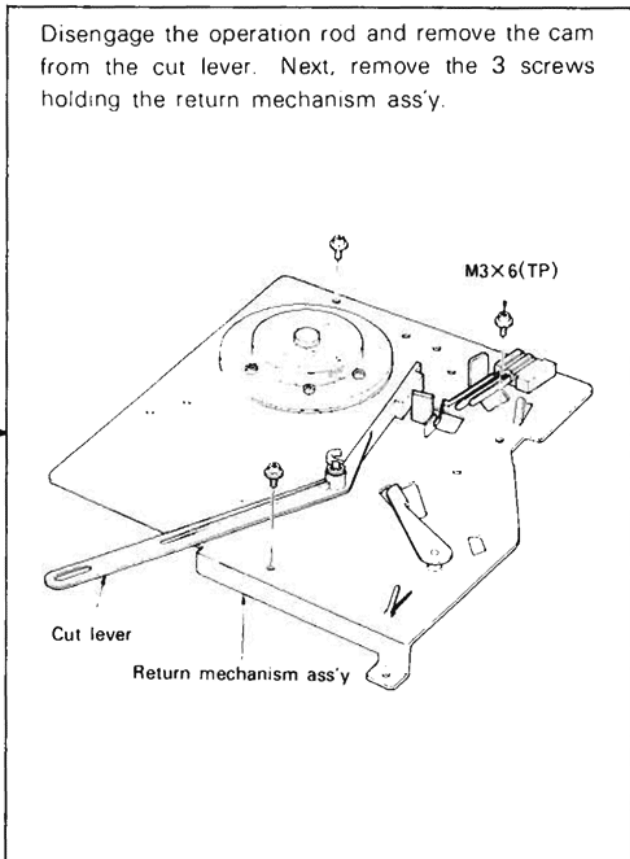

Note: Do not pull the return spring excessively.

ELEVATION SHAFT

Remove the screw holding the elevation shaft on the tonearm support, then remove the elevation shaft from the bottom side.

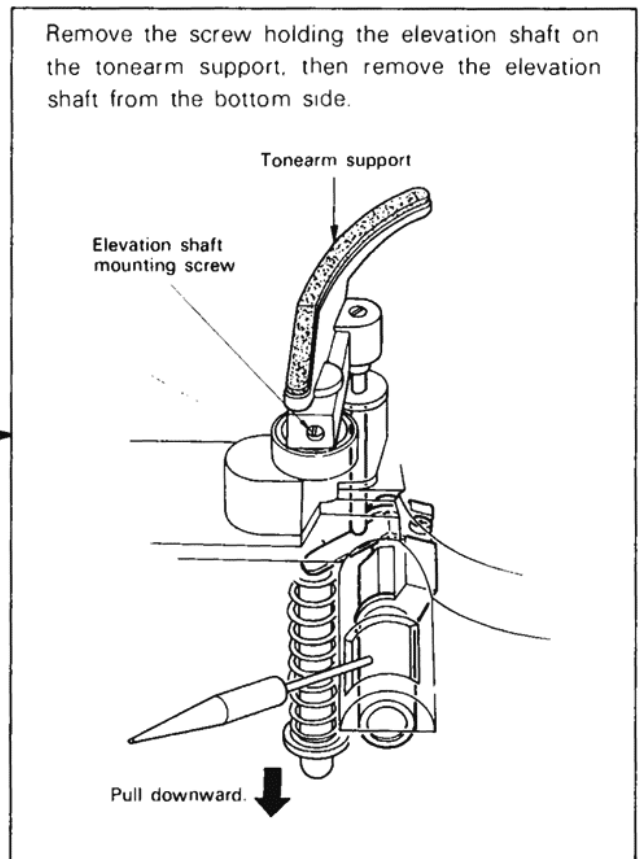

INSTALLATION

CAUTION

The return arm and the operation rod must be mounted correctly, otherwise the return mechanism will not function properly.

MOUNTING THE RETURN ARM

Mount the return arm at the angle illustrated, with the arm placed on the arm rest. Incorrect setting of the arm will cause it to move too fast or too slow, or will stop in the middle of the stroke.

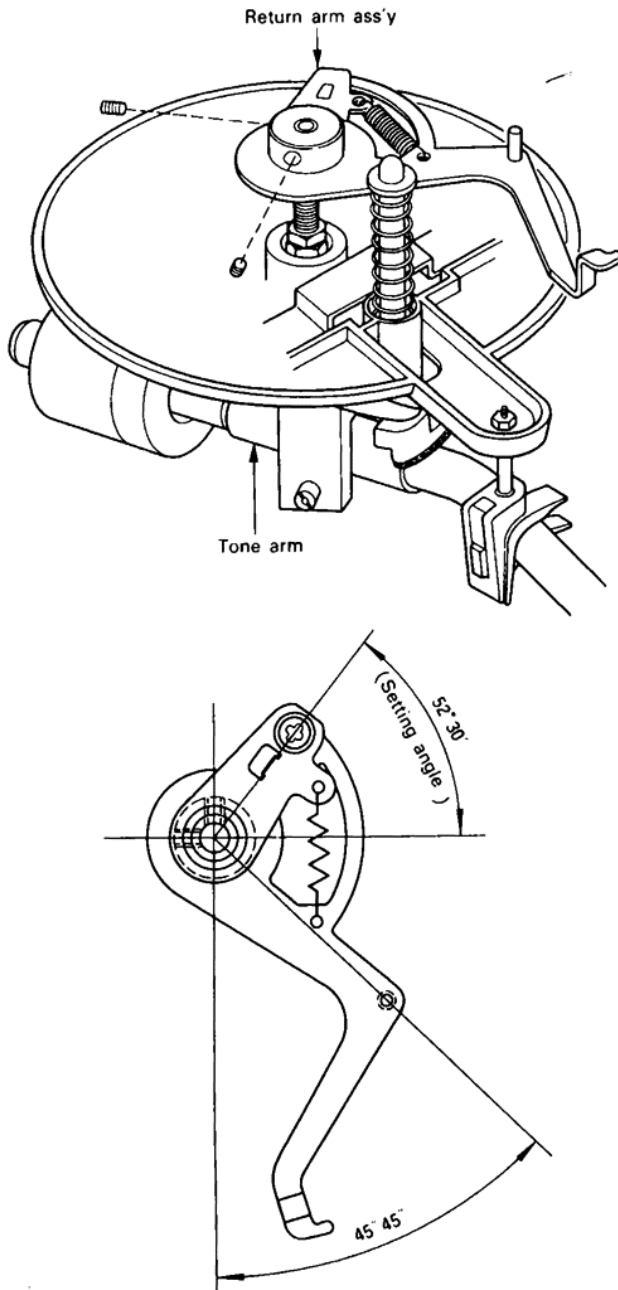

Note: The return arm must be level and perpendicular to the return mechanism chassis.

MOUNTING THE OPERATION ROD

In mounting the operation rod to the retainer, check the rod for the correct length (between the center cam calked ass'y and the rod retainer). If it is too long, the operation lever cannot be locked and returns to the original position; if it is too short, both the tone arm and operation lever stop in the middle of operation. Make sure that the tone arm returns to the arm rest before mounting the operation rod to the retainer. If the operation lever is not locked and returns to the original position, it is an indication that the center cam calked ass'y is not rotated completely and thus the center arm fails to be engaged with the center cam calked ass'y. In this case, move the operation mechanism ass'y backward before mounting the operation rod.

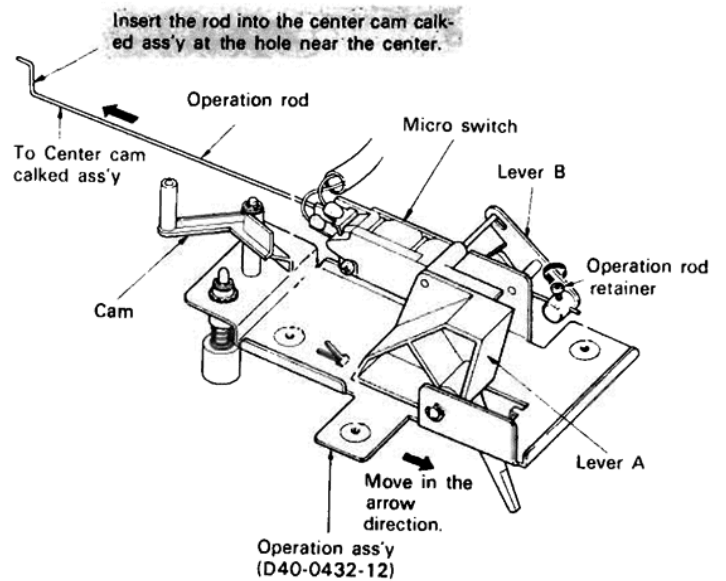

MOUNTING THE KNOB FOR ADJUSTING RETURN SPRING

Mounting the knob in the following sequence.

1. Hold the knob vertically.
2. Tighten the screw with the projection of the special pulley facing upward (hinge holder).

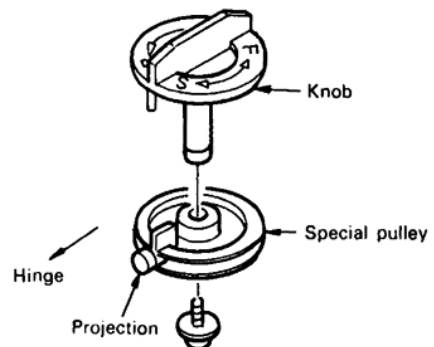

MECHANISM DESCRIPTION

RETURN MECHANISM

The operating principles of the return mechanism of KD-3070 are basically the same as those of KD-2055. In KD-2055, the return operation is effected when the detection arm is forced against the cut lever and the projection of the center arm is released from the depression of the center cam. In KD-3070, the return operation is started when the cut button is pressed and the projection of the center arm is released from the depression of the center cam.

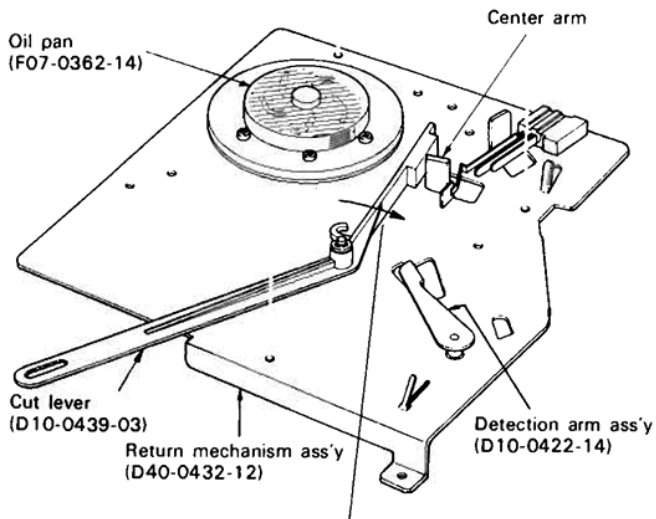

Pressing the cut button moves the center arm in the arrow direction.

PAUSE MECHANISM

In KD-3070, the pause mechanism is operated by the elevation-shaft auxiliary rod, not by the elevation shaft itself. The contact with the elevation-shaft auxiliary rod so that it moves contact with the elevation shaft auxiliary rod so that it moves up and down according to the movement of the pause lever (downward motion is made by the force of the spring).

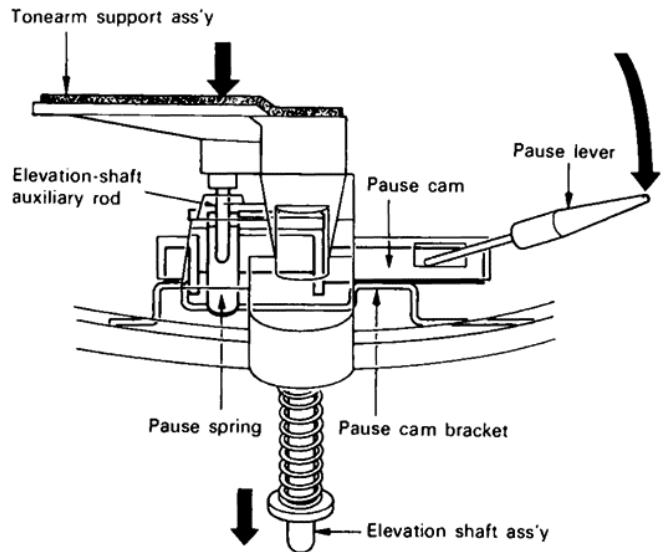

CORD BUSHING INSTALLATION

The cord bushing (Part No. J42-0312-05) matched with the audio and the power cord. When replacing the cord, should place it in the corrective position as the following figure.

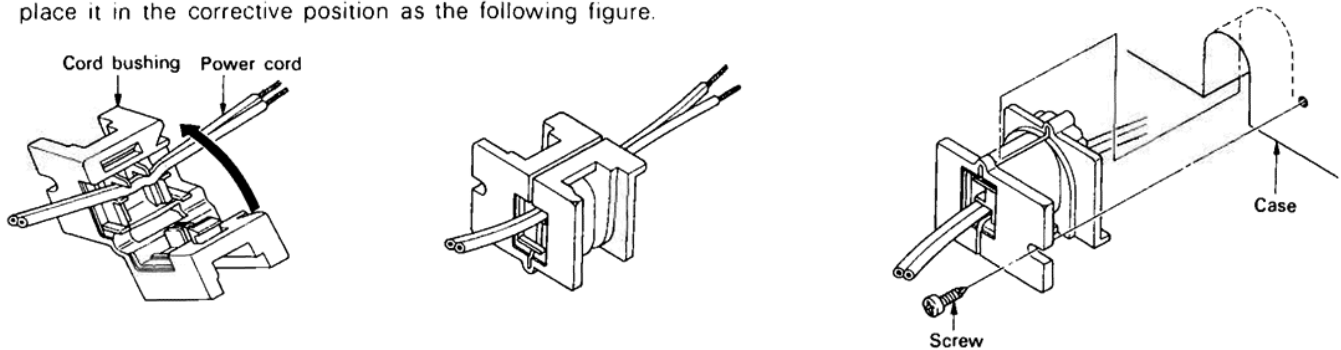

(1) Place the power cord in the upper slot, or do the Audio cord in the below slot.

(2) Squeeze the two segments together.

(3) Insert the cord bushing into the hole and fix it by screw.

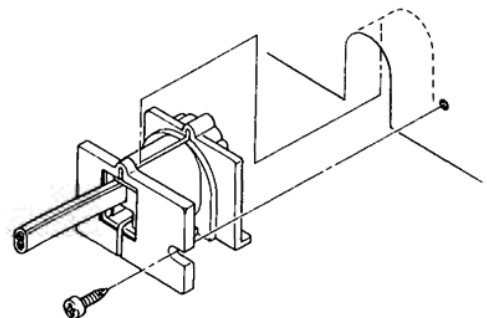
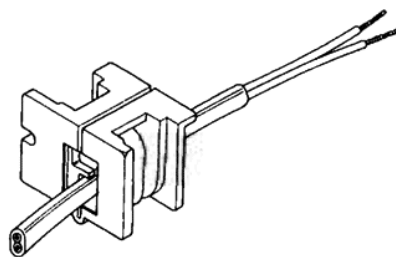
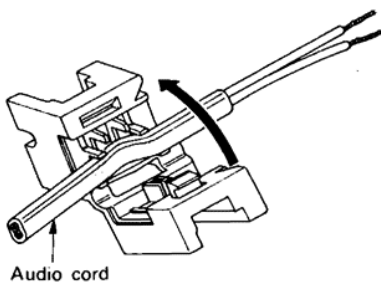

LUBRICATION

RETURN MECHANISM ASS'Y

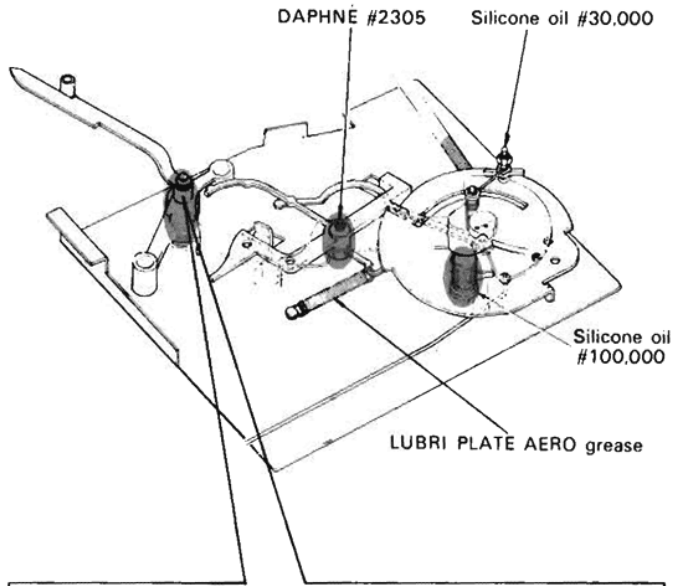

OPERATION MECHANISM CHASSIS ASS'Y

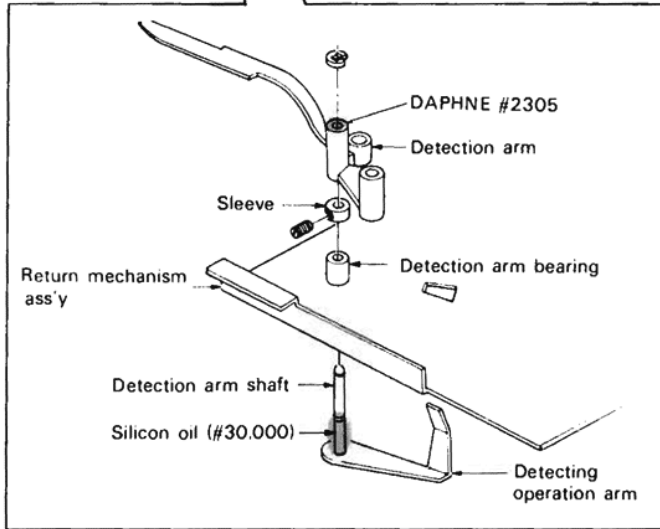
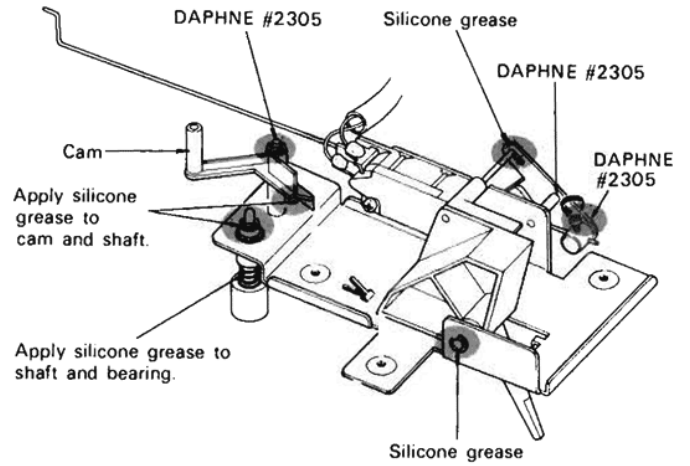

PAUSE/LIFTER MECHANISM

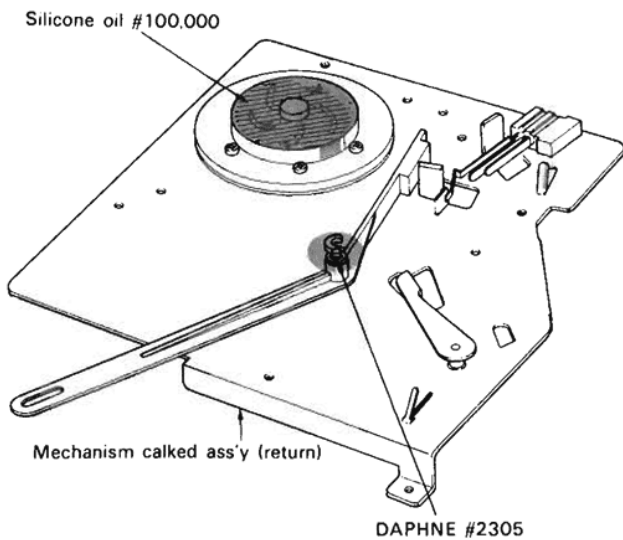
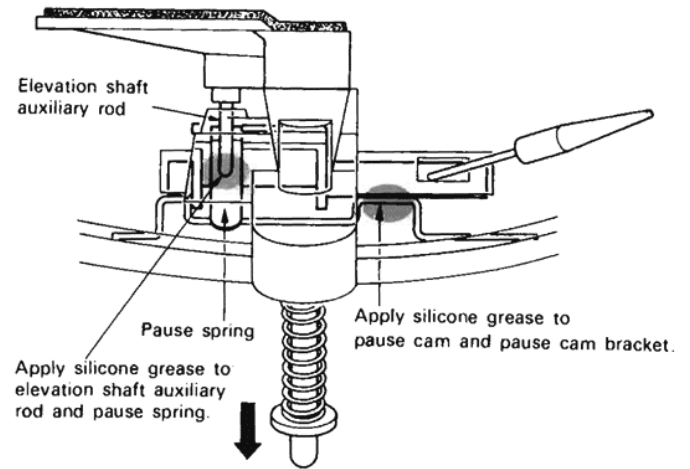

Kind of oil (オイルの種類)		Part No.
Silicone grease	シリコングリス	W 01-9990-00
Silicone oil (#300,000)	シリコンオイル (30万単位)	W 01-9991-00
DAPHNE #2035	ダフニ #2305	W 01-9995-09
LUBRI PLATE ARO grease	ループプレート エアログリス	W 01-9996-09
Silicone oil (#30,000)	シリコンオイル (3万単位)	W 01-9998-09

NOTE :

To make the oil of #100,000, mix #30,000 oil with #300,000 oil at the rate of 3 : 1.

(10万単位のオイルは3万単位と30万単位のオイルを3 : 1の割合で混ぜます。)

DESTINATIONS' PARTS LIST

☆ : New Parts

Ref. No.	U.S.A. (K)	Canada (P)	KD-3077 (U)	Australia (X)	Europe (W)	Scandinavia (L)	England (T)	South Africa (S)	Other Area (M)	Description
18	A03-0528-02	A03-0528-02	A03-0529-02	A03-0528-02	A03-0528-02	A03-0528-02	A03-0530-02	A03-0528-02	A03-0528-02	Turntable case ass'y ☆
103	B23-0004-04	B23-0004-04	—	—	—	—	B23-0004-04	—	—	Over hang gauge
102	B43-0524-03	B43-0524-03	B43-0526-03	B43-0524-03	B43-0524-03	B43-0524-03	B43-0525-03	B43-0524-03	B43-0524-03	Turntable case badge ☆
—	B46-0061-10	B46-0055-20	B46-0062-10	B46-0064-10	—	—	B46-0060-00	—	—	Warranty card
—	—	—	B46-0063-00	—	—	—	—	—	—	Warranty card
—	B50-2254-00	B50-2255-00	B50-2258-00	B50-2254-00	B50-2254-00	B50-2254-00	B50-2256-00	B50-2254-00	B50-2255-00	Instruction manual ☆
—	—	—	B59-0018-00	—	—	—	—	—	—	KENWOOD service stations' list
99	—	—	D32-0080-24	—	D32-0080-24	D32-0080-24	—	D32-0080-24	D32-0080-24	Switch stopper (voltage selector)
—	—	—	—	E23-0083-05	—	—	—	—	—	Lug type terminal ass'y
88	E30-0181-05	E30-0181-05	E30-1317-05	E30-0185-05	E30-0459-05	E30-0459-05	E30-0587-05	E30-0587-05	E30-1317-05	Power cord
90	E30-1320-05 ☆	E30-1319-05	E30-1319-05	E30-1319-05	E30-1319-05	E30-1319-05	E30-1319-05	E30-1319-05	E30-1319-05	Audio cord
—	F05-3012-05	F05-3012-05	—	—	—	—	—	—	—	Fuse (0.3A)
—	—	—	F05-8015-05	F05-8015-05	F05-8012-05	F05-8012-05	F05-8012-05	F05-8012-05	F05-8012-05	Fuse (0.8A)
84	F19-0510-02	F19-0509-02	F19-0509-02	F19-0509-02	F19-0509-02	F19-0509-02	F19-0509-02	F19-0509-02	F19-0509-02	Barrier ☆
80	G16-0314-13	G16-0312-03	G16-0312-03	G16-0312-03	G16-0312-03	G16-0312-03	G16-0312-03	G16-0312-03	G16-0312-03	Turntable sheet ass'y
—	H01-2258-04	H01-2261-14	H01-2260-14	H01-2258-14	H01-2258-14	H01-2258-14	H01-2259-14	H01-2258-14	H01-2258-14	Carton case ☆
16	J92-0036-05	J92-0036-05	J92-0037-05	J92-0037-05	J92-0037-05	J92-0037-05	J92-0036-05	J92-0037-05	J92-0037-05	Head shell ☆
24	L01-6071-05	L01-6071-05	L01-6157-05	L01-6157-05	L01-6154-05	L01-6154-05	L01-6154-05	L01-6157-05	L01-6157-05	Power transformer
100	—	—	N30-3006-45	—	N30-3006-45	N30-3006-45	—	N30-3006-45	N30-3006-45	Pan head screw M3 x 6 (switch stopper)
101	—	—	N87-3006-45	—	N87-3006-45	N87-3006-45	—	N87-3006-45	N87-3006-45	Tap tight screw (switch stopper)
98	—	—	S31-2001-05	—	S31-1006-05 ☆	S31-1006-05 ☆	—	S31-2001-05	S31-2001-05	Slide switch (power voltage selector)
17	—	—	T21-0046-05	T21-0046-05	T21-0046-05	T21-0046-05	—	T21-0046-05	T21-0046-05	Cartridge ass'y (V-39MKII)
81	X27-1270-01	X27-1270-02	X27-1270-04	X27-1270-04	X27-1270-03	X27-1270-03	X27-1270-03	X27-1270-04	X27-1270-04	Power supply ☆

EXPLODED VIEW PARTS LIST

☆ : New Parts. ★ : Refer to Destinations' Parts List.

Fig. No	Parts No.	Description	Remarks
1	A21-0656-05	Tonearm ass'y	☆ 1B
2	D91-0112-08	Weight ass'y	☆ 1B
3	J19-1240-08	Tonearm base	☆ 2B
4	N77-4010-45	Tonearm setscrew	2B
5	D19-0206-08	Canceller ass'y	☆ 1B
6	N08-0406-08	Dress screw	☆ 1B
7	J19-1246-08	Canceller clink	☆ 2B
8	D39-0071-08	Tonearm support	☆ 2B
9	D39-0072-08	Tonearm rest ass'y	☆ 2B
10	D40-0435-08	Pause ass'y	☆ 2B
11	D12-0209-08	Pause cam	☆ 2B
12	D10-0503-08	Pause lever	☆ 2B
13	G02-0310-08	Pause spring	☆ 2B
14	D21-0633-08	Lifter shaft ass'y	☆ 2B
15	G01-0647-08	Compression spring	☆ 2B
16	J92-0035-05	Head shell	☆ 1A
17	★	Cartridge ass'y	2B
18	★	Turntable case ass'y	☆ 2A
19	T43-0009-05	DD motor	3A
20	K29-0287-14	Knob for adjusting return spring	2A
21	D10-0460-04	Knob base	☆ 2A
22	D15-0169-14	Special pulley	2A
23	G01-0670-04	Compression spring	☆ 2A
24	★	Power transformer	2A
25	G13-0414-04	Insulating rubber	☆ 2A
26	J31-0416-04	Collar	☆ 3A
27	A21-0653-14	Operation panel ass'y	☆ 1A
28	K27-0302-14	Speed selector knob	2A
29	K23-0605-24	Speed adjusting knob	2A
30	B07-0505-24	Lamp base	1A
31	F07-0611-04	Lamp cover	1A
32	B30-0709-05	Neon lamp	☆ 1A
33	D40-0431-23	Operation ass'y	☆ 2B
34	A11-0312-23	Mechanism chassis calked ass'y	☆ 2B
35	D10-0461-13	Lever A	☆ 2B
36	D21-0620-04	Lever A shaft	☆ 2B
37	K29-0628-14	Cut button	☆ 2B
38	G01-0348-04	Compression spring	2B
39	D10-0462-04	Lever B	☆ 2B
40	D12-0204-14	Cam	☆ 2B
41	D23-0508-04	Rod retainer	☆ 2B
42	S50-1016-05	Micro switch	2B
43	N09-0195-05	Polycarbonate screw	2B
44	D40-0432-12	Return ass'y	3B
45	A11-0314-03	Return mechanism chassis calked ass'y	☆ 3B
46	D12-0083-24	Center cam calked ass'y	3B
47	D12-0073-14	Cross cam	2B
48	G01-0282-14	Cross cam spring	2B
49	G01-0608-04	Tension spring	☆ 3B
50	D10-0244-14	Reset arm	3B
51	D10-0422-14	Detection operating arm ass'y	3B
52	D11-0184-25	Center arm	3B
53	G01-0291-04	Tension spring	3B
54	D19-0046-04	Control runner	3B
55	F07-0362-14	Oil pan	3B
56	G50-0014-04	Packing	3B
57	G53-0041-05	Mini-packing	3B
58	D10-0466-04	Detection operating arm	☆ 3B

Fig. No.	Parts No.	Description	Remarks
59	J31-0402-04	Sleeve	3B
60	N72-2604-46	Set screw (M2.6 × 4)	3B
61	D10-0463-04	Operation rod	☆ 2B
62	D10-0439-03	Cut lever	☆ 3B
63	D10-0492-04	Return arm ass'y	☆ 2B
64	D10-0495-04	Return arm calked ass'y	☆ 2B
65	N30-3010-46	Pan head screw (M3 × 10)	2B
66	G01-0141-04	Tension spring (B)	2B
67	G01-0675-04	Conical spring	☆ 2B
68	N77-3004-46	Set screw	2B
69	B07-0506-04	Button base	☆ 2A
70	B07-0507-14	Lever base	☆ 2A
71	J09-0303-04	Shell stand	2A
72	A40-0517-05	Bottom case	☆ 3B
73	J02-0318-05	Insulator	☆ 3A,3B
74	K29-0229-15	Detection adjusting knob	2A
75	D02-0023-05	Turntable platter	☆ 1A
76	D19-0032-04	Trip pin	1A
77	A53-0210-02	Turntable cover ass'y	☆ 1B
78	J50-0310-05	Turntable cover hinge (1)	☆ 1B
79	J50-0308-05	Turntable cover hinge (2)	1B
80	★	Turntable sheet ass'y	1A
81	★	Power supply PC board ass'y	☆ 2A
82	S40-2301-05	Pushbutton switch	2A
83	R01-1304-05	Potentiometer	☆ 2A,3A
84	★	Barrier	☆ 2A
85	J19-0306-05	Lead holder	2B
86	J61-0044-15	Cramper	2A
87	J61-0052-15	Cramper	2A
88	★	Power cord	3A
89	J42-0312-05	Cord bushing A	3A
90	★	Audio cord	3B
91	J42-0313-05	Cord bushing	3B
92	W01-0057-14	EP adaptor	1A
93	S46-2013-13	Muting switch	3B
94	J11-0307-05	V shaped cramper	☆ 2A
95	N09-0588-05	Cartridge mounting screw (M2.6 × 9)	1B
96	N19-0516-05	Cartridge mounting washer	1B
97	N14-0108-05	Cartridge mounting nut	2B
98	★	Slide switch (power voltage)	2A
99	★	Switch stopper	2A
100	★	Pan head screw	2A
101	★	Tap tight screw	2A
102	★	Turntable case badge	2A
103	★	Over hang gauge	1A

SCHEMATIC DIAGRAM

(J) TYPE

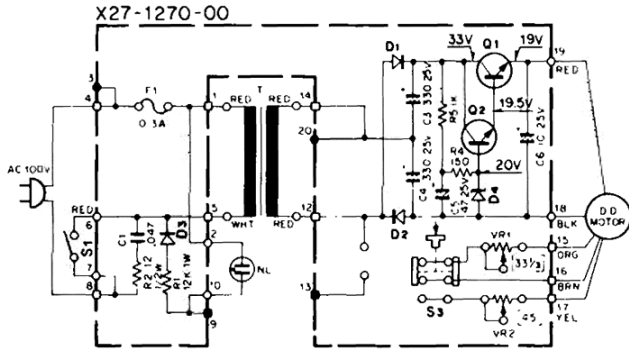

(U),(M),(S) TYPE

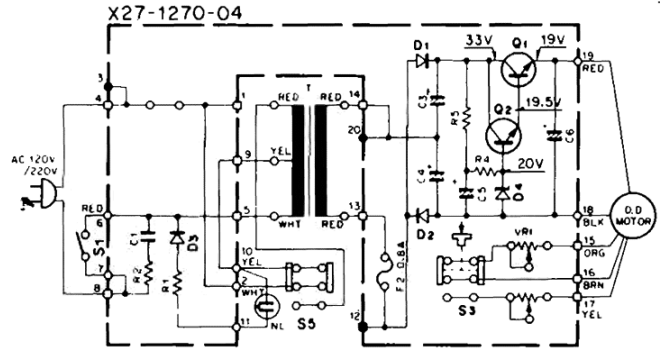

(X) TYPE

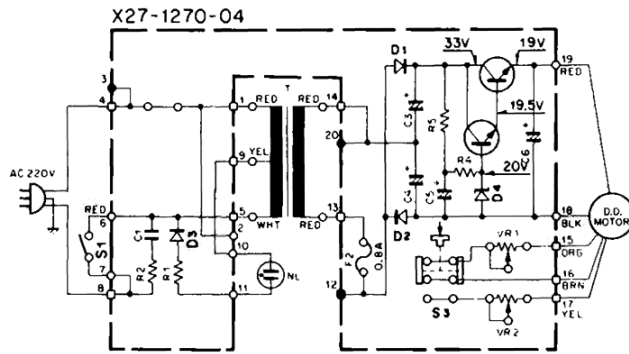

(K),(P) TYPE

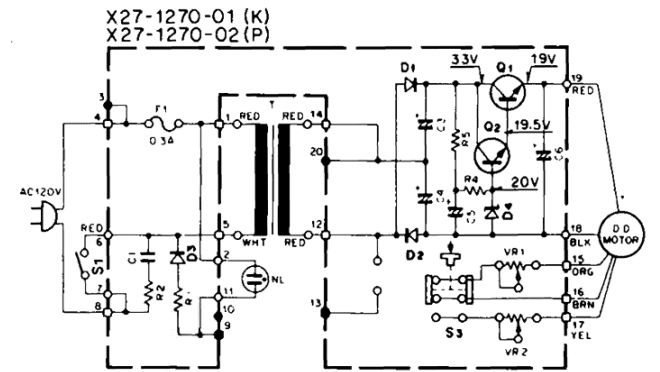

(W),(L) TYPE

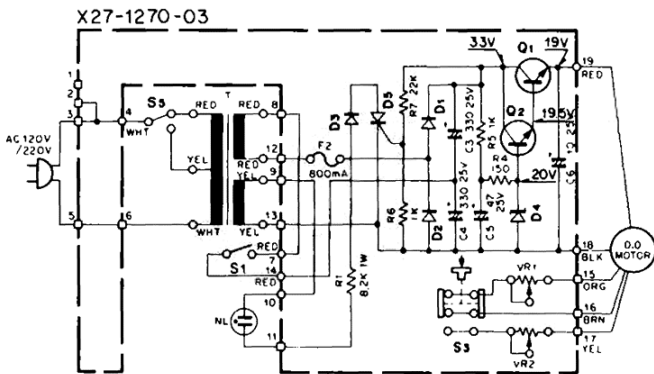

(T) TYPE

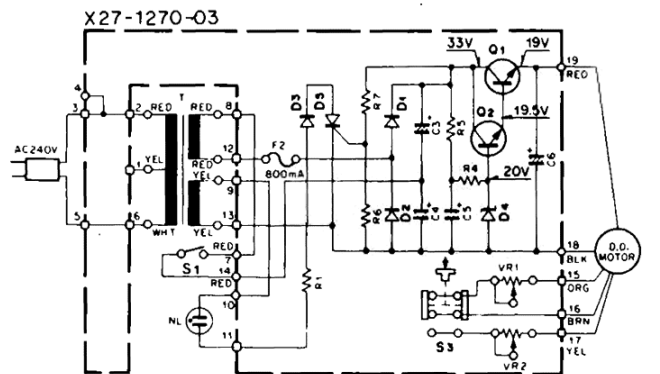

- Q1 : 2SC1419(C) VR1, 2 : 2KΩ(B)
- Q2 : 2SC945
- D1-3 : VD6C
- D4 : WZ-192
- D5 : IRC-20

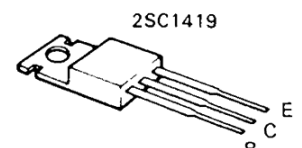
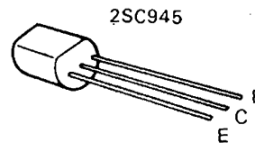
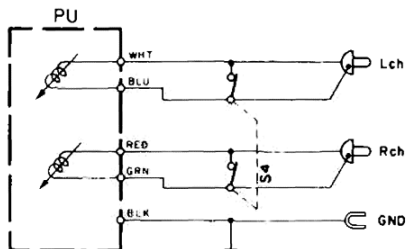

PARTS LIST (X27-1270-00) / PACKING

Ref. No.	Parts No.	Description	Re- marks
CAPACITOR			
C1	C91-0309-05	0.047 μ F (X27-1270-00, -04)	
	C91-0302-05	0.047 μ F (X27-1270-01)	
	C91-0024-05	0.047 μ F (X27-1270-02)	
	—	Omit (X27-1270-03)	
C3.4	CE04W1E331	Electrolytic 330 μ F, 25WV	
C5	CE04W1E470	Electrolytic 47 μ F 25WV	
C6	CE04W1E100	Electrolytic 10 μ F 25WV	
RESISTOR			
R1	RS14AB3A123J	Metal film 12k Ω \pm 5% 1W (X27-1270-00, -01, -02, -04)	
	RS14AB3A822J	Metal film 8.2k Ω \pm 5% 1W (X27-1270-03)	
R2	RC05GF2H120K	Carbon 12 Ω \pm 5% 1/2W (X27-1270-00, -01, -02, -04)	
R4~7	RD14BY2E000J	Carbon 000 Ω \pm 5% 1/4W Refer to schematic.	

Ref. No.	Parts No.	Description	Re- marks
SEMICONDUCTOR			
Q1	V03-0343-05	Transistor 2SC1419 (C)	
Q2	V03-0293-05	Transistor 2SC945 (Q)	
D1~3	V11-0200-05	Diode V06C	
D4	V11-0308-05	Zener diode WZ-192	
D5	V11-0323-05	SCR SCR-IRC20	
MISCELLANEOUS			
—	F19-0509-22	Barrier (X27-1270-02, -03, -04)	☆
—	F19-0510-02	Barrier (X27-1270-01)	☆
—	J13-0055-05	Fuse holder x 2	
VR1.2	R01-1304-05	Potentiometer 2k Ω (B)	☆
S3	S40-2301-05	Push-button switch	

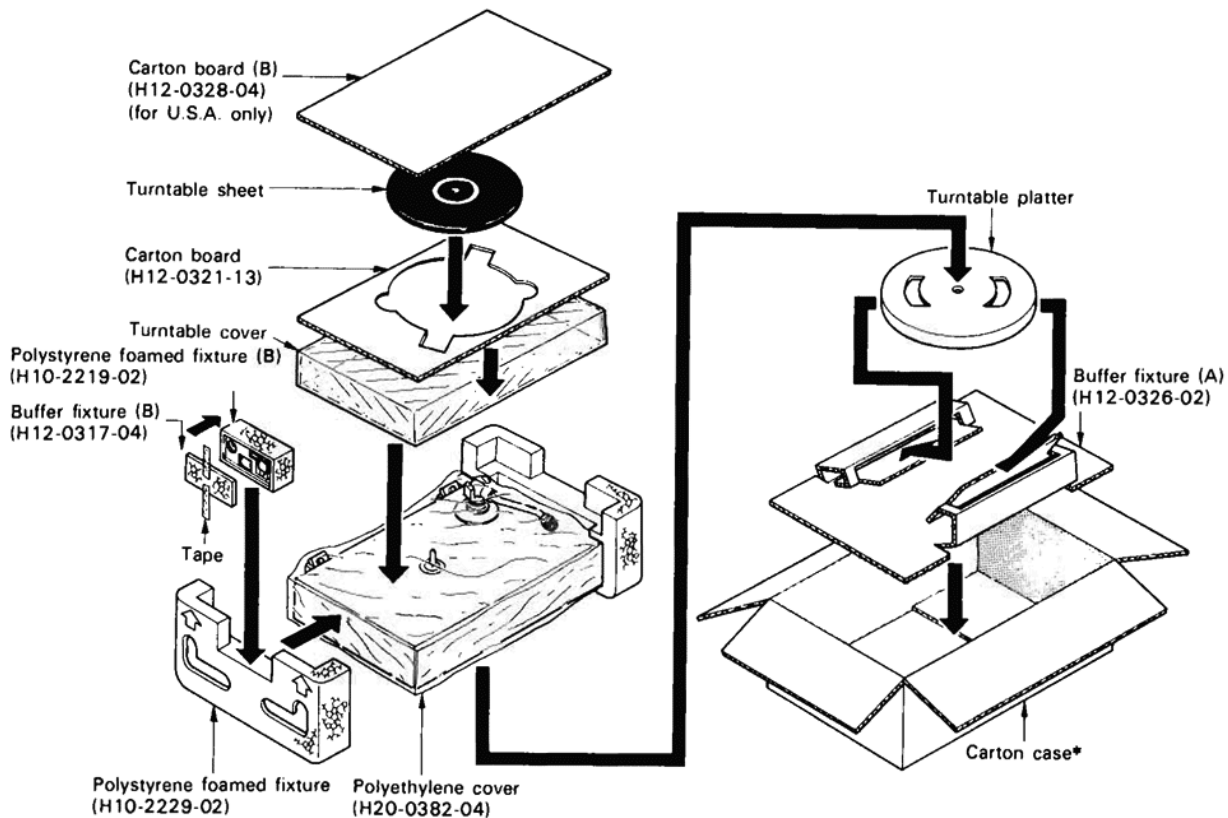

* Refer to Destinations' Parts List.

SPECIFICATIONS

MOTOR AND TURNTABLE

Drive System	Direct drive system
Motor	20-pole, 30 slot D.C. servo motor
Turntable Platter	31 cm (12-3/16") diameter 1.15 kg (2.54 lbs.) weight Aluminium alloy, die-cast
Speeds	2 speeds, 33-1/3 and 45 r.p.m.
Speed Control Range	Within $\pm 3\%$
Wow and Flutter	Less than 0.035% (WRMS)
Rumble	DIN unweighted Better than -50 dB DIN weighted Better than -70 dB

TONARM

Type	Static-balance type, S-shaped pipe arm
Effective Arm Length	225 mm (8-7/8")
Over-hang	15 mm (9/16")
Tracking Error	± 1.5 degree
Tracking Force Variable Range	0 to 3 grams
Usable Cartridge Weight	3 to 10 grams (with supplied headshell)

CARTRIDGE (U.S.A., Canada and U.K. model are equipped with the V-39 MKII)

Furnish Cartridge	V-39 MKII
Frequency Response	20 ~ 20,000 Hz
Output Voltage	3 mV (1,000 Hz, 5 cm/sec.)
Load Impedance	50k ohms
Stylus	0.5 mil diamond
Optimum Tracking Force	2 \pm 0.5 grams
Replacement Stylus	N-39 MKII

MISCELLANEOUS

Power Requirement	AC 120V, 60 Hz: U.S.A. and Canada Model AC 240V, 50 Hz: U.K. Model AC 220V, 50 Hz: Australia Model AC 120/220V (Switchable.) 50/60 Hz: Other Countries
Power Consumption	7 watts
Dimensions	W 480 mm (18-7/8") H 156 mm (6-1/8") D 365 mm (14-3/8")
Weight	8.6 kg (18.9 lbs.)
Built-in Features	Auto-return/cut tonearm system, Anti-skating device, Viscous-damped cueing device, Illuminated stroboscope, Speed adjustment control, Low capacitance photo cables, Headshell stand, Free-stop action dust cover, Tracking force direct readout counter, Built-in insulator
Supplied Accessories	EP adaptor

Note: Kenwood follows a policy of continuous advancements in development. For this reason specifications may be changed without notice.

KENWOOD ELECTRONICS, INC.

- 1315 E.WATSON CENTER RD. CARSON, CALIFORNIA 90248 U.S.A.
- 75 SEAVIEW DRIVE SECAUCUS, NEW JERSEY 07094 U.S.A.

TRIO-KENWOOD ELECTRONICS N.V.

- LEUVENSESTEENWEG 184, B-1930 ZAVENTEM, BELGIUM.

TRIO-KENWOOD ELECTRONICS GmbH.

- 6056 HEUSENSTAMM, RUDOLF-BRAAS-STR. 20, WEST GERMANY.

TRIO-KENWOOD FRANCE S.A.

- 5, BOULEVARD NEY 75018 PARIS, FRANCE.

TRIO-KENWOOD (AUSTRALIA) PTY, LTD.

- 30 WHITING ST., ARTARMON N.S.W. 2064, AUSTRALIA.

TRIO-KENWOOD CORPORATION

- 3-6-17 AOBADAI, MEGURO-KU, TOKYO, JAPAN.