

INSTALLATION & OPERATION MANUAL

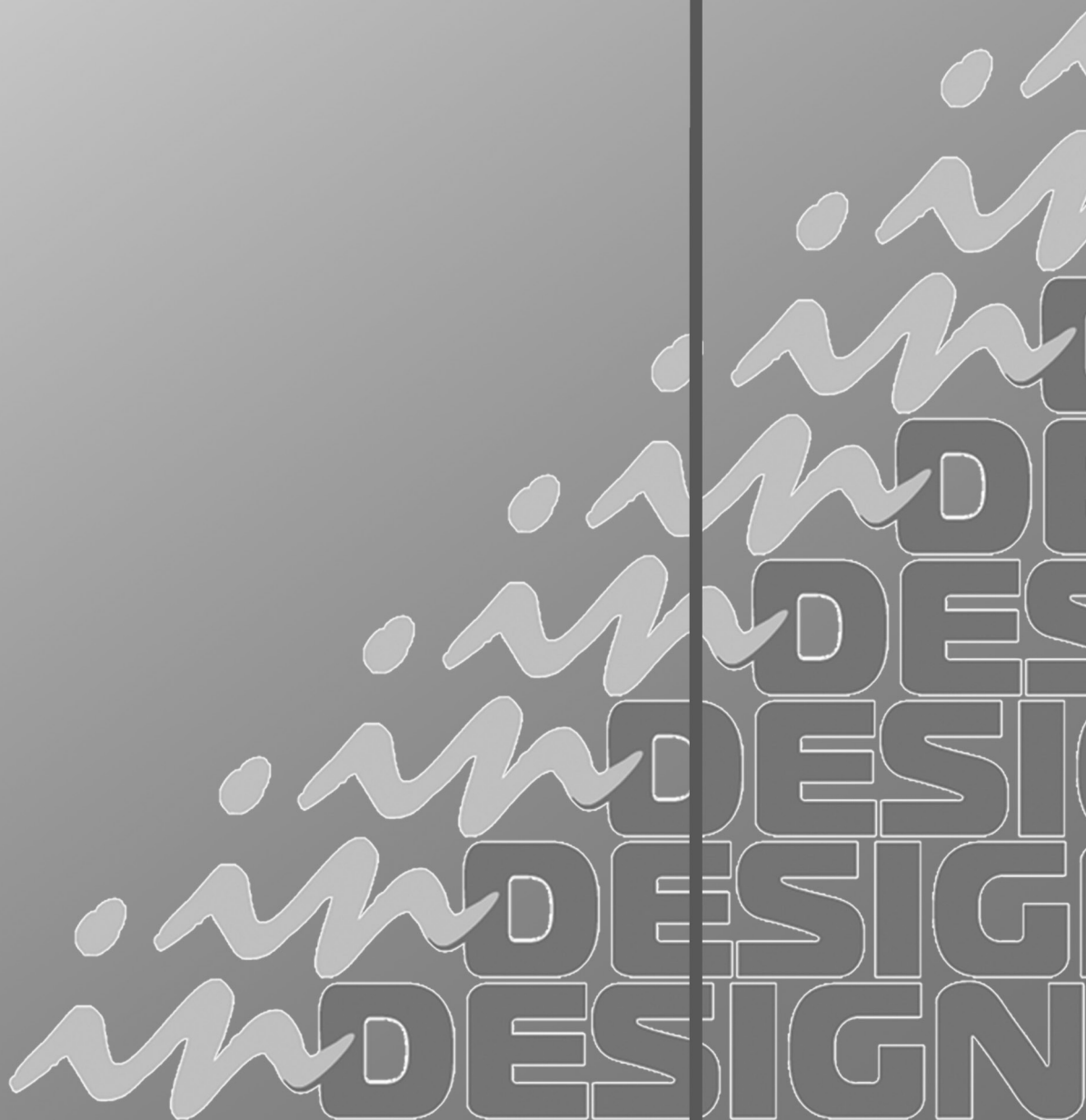

iD-S9920-OPT

ACTIVE SOUND BAR



CONTENTS

INTRODUCTION	2
IMPORTANT SAFETY INSTRUCTIONS	3
WHAT'S INCLUDED	4
PRODUCT OVERVIEW	5
CONNECTING ELECTRICAL POWER	6
CONNECTING WITH A TV	6
CONNECTING AN EXTERNAL DEVICE	8
CONNECTING A USB	9
CONNECTING A BLUETOOTH DEVICE	9
KNOW YOUR REMOTE	10
INSTALLING THE WALL MOUNT	11
TROUBLESHOOTING	12
IMPORTANT NOTES ABOUT SERVICE	12
SPECIFICATIONS	13
WARRANTY INFORMATION	14

INTRODUCTION

Active Sound Bar

Enhance your viewing experience with this sound device.

The iD-S9920-OPT TV Sound Bar is Bluetooth compatible for wireless streaming of music from your smartphone, tablet or media device.

Electrical and Safety Warnings

CAUTION

THESE SERVICE INSTRUCTIONS ARE FOR USE BY QUALIFIED SERVICE PERSONNEL ONLY. TO REDUCE THE RISK OF ELECTRIC SHOCK DO NOT PERFORM ANY SERVICING OTHER THAN THAT CONTAINED IN THE OPERATING INSTRUCTIONS UNLESS YOU ARE QUALIFIED TO DO SO.



The lightning flash with arrowhead symbol, with an equilateral triangle, is intended to alert the user to the presence of un-insulated "dangerous voltage" within the products enclosure that may be of sufficient magnitude to constitute a risk of electric shock to persons.

CAUTION

**RISK OF ELECTRIC SHOCK
DO NOT OPEN**

WARNING: TO REDUCE THE RISK OF ELECTRIC SHOCK, DO NOT REMOVE COVER (OR BACK). NO USER SERVICEABLE PARTS INSIDE. REFER SERVICING TO QUALIFIED SERVICE PERSONNEL.
WARNING: TO REDUCE THE RISK OF FIRE OR ELECTRICAL SHOCK, DO NOT EXPOSE THIS APPLIANCE TO RAIN OR MOISTURE.



The exclamation point within an equilateral triangle is intended to alert the user to the presence of important operating and maintenance (servicing) instructions in the literature accompanying the appliance.

IMPORTANT SAFETY INSTRUCTIONS

WARNING: USE UNDER SUPERVISION OF AN ADULT DUE TO LONG CORD.

This unit has a long cord that can be easily tripped on or pulled on, causing injury.







Please make sure it is arranged so that it will not drape over a tabletop, etc., where it can be pulled on by children or tripped over accidentally.

Before using the unit, be sure to read all operating instructions carefully. Please note that these are general precautions and may not pertain to your unit. For example, this unit may not have the capability to be connected to an outdoor antenna.

1. Read these instructions – All the safety and operating instructions should be read before the appliance is operated.
2. Keep these instructions – The safety and operating instructions should be kept for future reference.
3. Heed all warnings – All warnings on the appliance and in the operating instructions should be adhered to.
4. Follow all instructions – All operation and use instructions should be followed.
5. Do not use this apparatus near water – The appliance should not be used near water; for example, near a bath tub, washbowl, kitchen sink, laundry tub, in a wet basement, or near a swimming pool.
6. Clean only with dry cloth – The appliance should be cleaned only as recommended by the manufacturer.
7. Do not block any ventilation openings. Install in accordance with the manufacturer's instructions. The appliance should be situated so that its location or position does not interfere with its proper ventilation. For example, the appliance should not be situated on a bed, sofa, rug, or similar surface that may block the ventilation openings; or placed in a built-in installation, such as a bookcase or cabinet that may impede the flow of air through the ventilation openings.
8. Do not install near any heat sources such as radiators, heat registers, stoves, or other apparatus (including amplifiers) that produce heat.
9. Do not defeat the safety purpose of the polarised or grounding-type plug. A polarised plug has two blades and a third grounding prong. The wide or the third prong are provided for your safety. If the provided plug does not fit into your outlet, consult an electrician for replacement of the obsolete outlet.
10. Protect the power cord from being walked on or pinched particularly at plugs, convenience receptacles, and the point where they exit from the apparatus.
11. Only use attachments / accessories specified by the manufacturer.
12. Use only with a cart, stand, tripod, bracket, or table specified by the manufacturer, or sold with the apparatus. When a cart is used, use caution when moving the cart/apparatus combination to avoid injury from tip-over.
13. Unplug this apparatus during lightning storms or when unused for long periods of time.
14. Refer all servicing to qualified service personnel. Servicing is required when the apparatus has been damaged in any way, such as power-supply cord or plug is damaged, liquid has been spilled or objects have fallen into the apparatus, the apparatus has been exposed to rain or moisture, does not operate normally, or has been dropped.
15. This appliance should not be exposed to dripping or splashing water and no object filled with liquids such as vases should be placed on the apparatus.
16. Power Sources – The appliance should be connected to a power supply only of the type described in the operating instructions or as marked on the appliance. Do not overload wall outlet.
17. Battery should not be exposed to excessive heat such as sunshine, fire, etc.
18. Replace remote control battery only with the same or equivalent type.
19. Do not attempt to dismantle, open or repair this product yourself. If a problem occurs, seek advice from your local qualified service technician or contact the distributor at the telephone number at the back of this instruction manual.
20. Caution marking and nameplate are located on back or bottom of product.

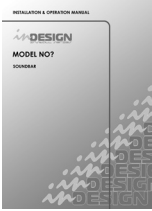

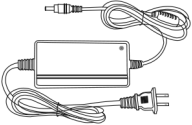
WHAT'S INCLUDED

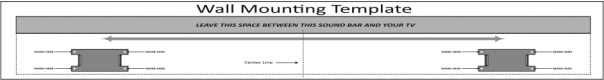
	iD-S9920 Sound Bar
	Remote Control
	User Manual
	Digital Optical Cable
	Stereo RCA 50 3.5mm Audio Cable
	Power Adapter
	Wall Mount Brackets
	Mount Screws
	Wall Mount Template

PRODUCT OVERVIEW

Front Panel / Right Side Panel of the Sound Bar

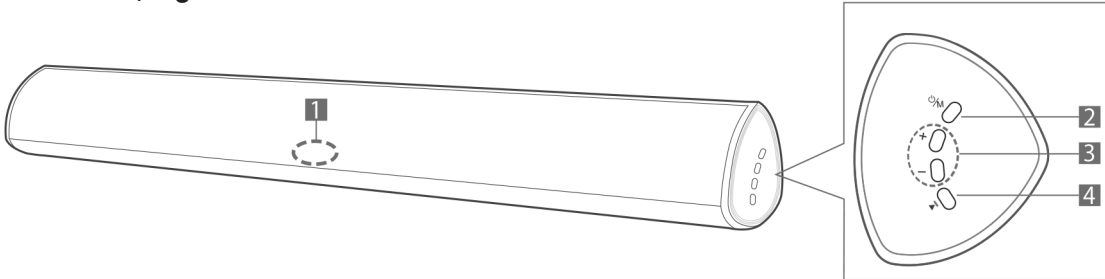

1. **LED INDICATOR:** Displays current mode using the following colours –

BLUE	Bluetooth
WHITE	Optical
GREEN	Coaxial
LIGHT BLUE	AUX1 (R/L)
YELLOW	AUX2
PURPLE	USB

2. **POWER / MODE:** Turns power on or selects the source input mode. Press and hold for power off.
3. **VOL+ / VOL-:** Adjusts the volume. When adjusting, the LED indicator will flash until MAX or MIN volume is reached.
4. **PLAY/PAUSE:** Play or pause audio.
- When you plug in the power cord, allow 2-4 seconds for the buttons to begin working.
 - If you want to enjoy sound only from the Sound Bar, you must turn off your TV's speakers in the Audio Setup menu of your TV. Refer to the owner's manual supplied with your TV.

Bottom Panel of the Sound Bar

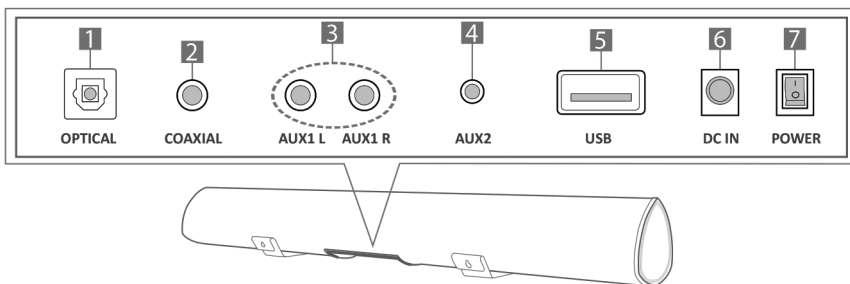

1. **DIGITAL AUDIO IN (Optical):** Connects to the digital (optical) output of an external device.
2. **COAXIAL AUDIO IN:** Connects to the digital (coaxial) output of an external device.
3. **AUX1 (L/R):** Connects to the analog output of an external device.
4. **AUX2 (3.5mm jack):** Connects to the analog output of an external device.
5. **USB:** Connect a USB device here to play music files from the USB device through the Sound Bar.
6. **DC IN (Power supply in):** Connects the AC/DC power adapter.
7. **POWER:** Press to power on/off.
- When disconnecting the power cable of the DC/AC power adapter from a wall outlet, pull the plug. Do not pull the cable.
 - Do not connect this unit or other components to an AC outlet until all connections between components are completed.

CONNECTING ELECTRICAL POWER

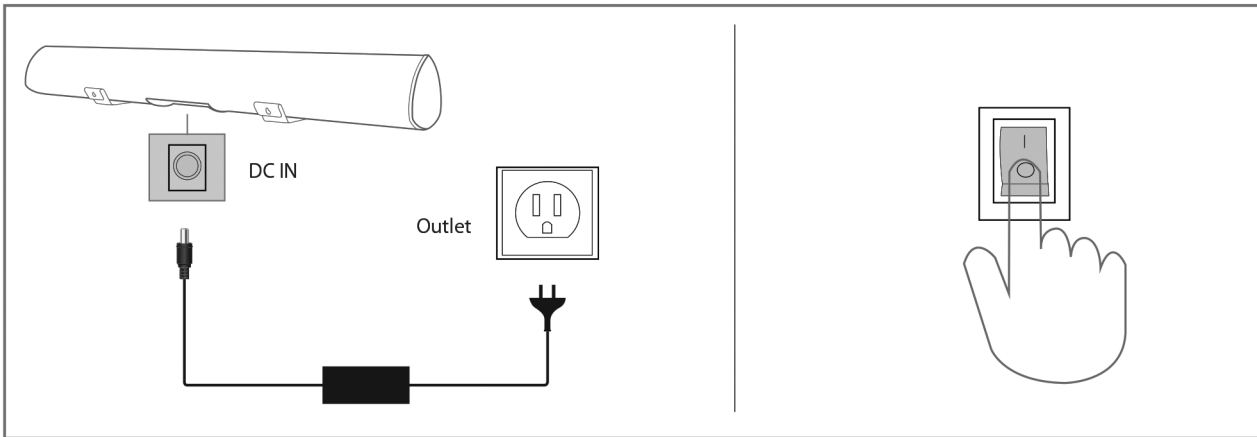

1. Using the power adapter, connect the unit to electrical outlet as shown.
 2. Press the "POWER" switch to turn on the Sound Bar (LED indicator should be on).
- Make sure to rest the AC/DC adapter flat on a table or the floor. If you place the AC/DC adapter so that it is hanging with the AC cord input facing upwards, water or other foreign substances could enter the adapter and cause the adapter to malfunction.

CONNECTING WITH A TV

Method 1: Connecting with an Optical cable

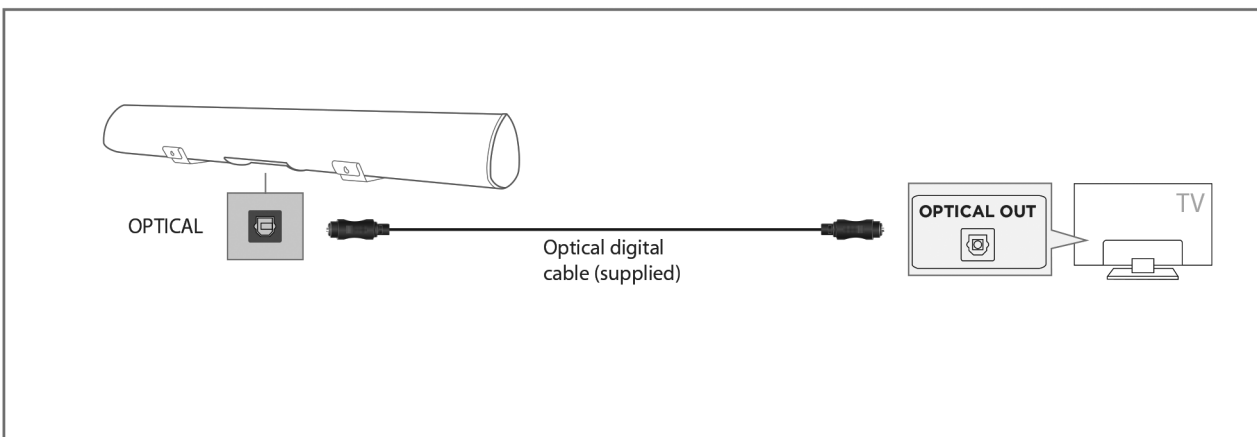

1. Connect the DIGITAL AUDIO IN (OPTICAL) jack on the Sound Bar to the OPTICAL OUT jack of the TV with the digital optical cable supplied.
2. Press the "OPT" button on the remote, and the LED indicator will be **WHITE**.

- You must use the Sound Bar's remote to turn power on or control the volume under this connection.
- If there is no sound or a cracking noise, set your TV's audio output to "PCM" (refer to TV's manual).

* NOTE: Take the caps off on the OPTICAL jack.

Method 2: Connecting with a Coaxial cable

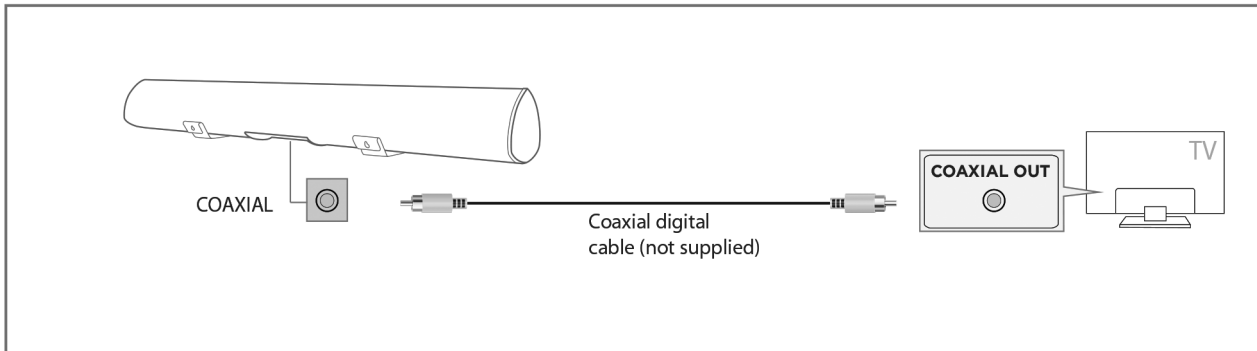

1. With the Sound Bar and TV turned on, connect the Coaxial cable as shown.
 2. Press the "COAX" button on the remote or on the right side of the Sound Bar to switch to "Coaxial" mode. The LED will be **GREEN** and TV sound will play.
- You must use the Sound Bar's remote to turn power on or control the volume under this connection.
 - If there is no sound or a cracking noise, set your TV's audio output to "PCM". (Refer to TV's manual).

Additional Information: How to change my TV to PCM

1. Press "MENU" on the remote control. If you do not have a remote control, press "MENU" on the television.
 2. Press the arrow keys on the remote to scroll to "Audio Settings." If you do not have a remote control, press the "VOL+" and "VOL-" buttons to scroll.
 3. Press "OK" on the remote control. Press "ENTER" on the television if you do not have a remote. If the television does not have an "ENTER" button, the "MENU" button is often used.
 4. Scroll to "Advanced Audio" and press "OK." Some televisions may not have an "Advanced Audio" menu and may list various audio settings instead.
 5. Scroll to "Audio Output Mode" or "Digital Audio Output Mode" and press "OK".
 6. Scroll until "PCM" is displayed as the current audio output.
 7. Press "OK" to save the settings.
- Depending on the model of your television, steps maybe different, please refer to your TV's manual.

Method 3: Connecting via AUX1/AUX2

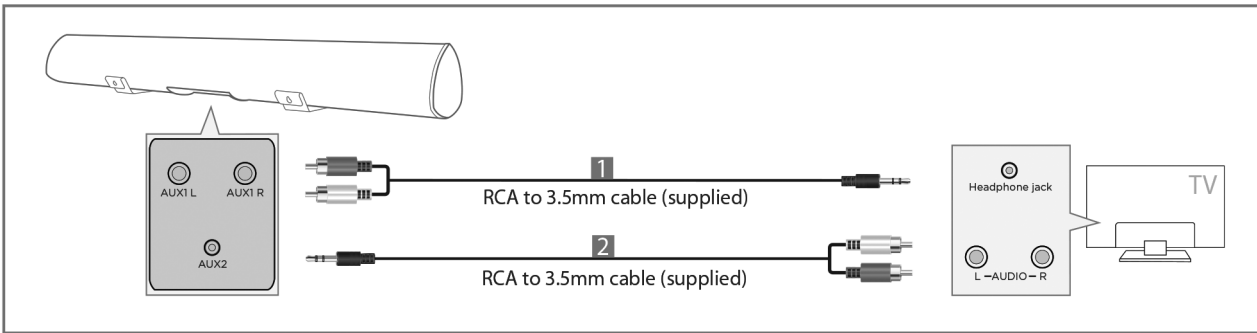

- [1]** Connect AUX1 (L/R) on the Sound Bar to the AUDIO OUT (Headphone) jack of the TV using the RCA to 3.5mm cable.
Press "AUX1" on the remote. LED indicator will be **LIGHT BLUE**.
- [2]** Connect AUX2 on the Sound Bar to the AUDIO OUT (L/R) jack of the TV using the RCA to 3.5mm cable.
Press "AUX2" on the remote. LED indicator will be **YELLOW**.

- If there is no sound or an echo, set your TV's audio output to external speaker (Refer to TV's manual).
- Choose only one connection from above, it depends on your TV's audio output jack.

CONNECTING AN EXTERNAL DEVICE

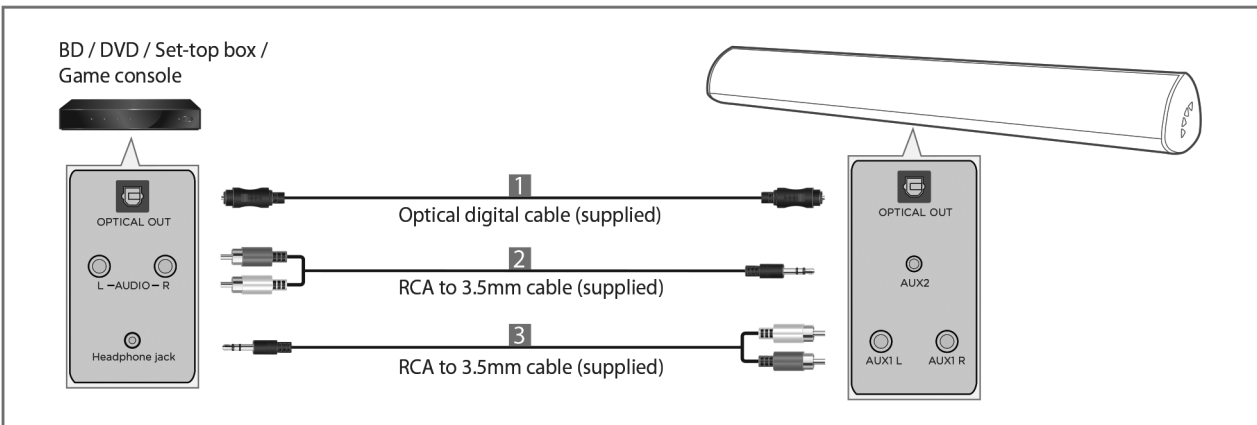

An external device can be connected via **1**. Optical cable, or **2/3**. RCA to 3.5mm cable.

To connect via Optical cable, refer to Page 6.

To connect via RCA to 3.5mm cable, refer to Page 8 (above).

CONNECTING A USB

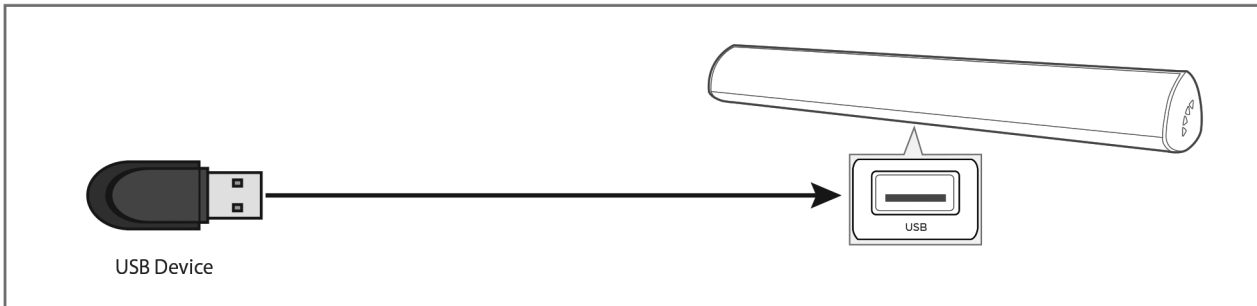

1. Connect your USB device to the USB jack on the Sound Bar.
2. Press the "USB" button on the remote. LED indicator will be **PURPLE**.
3. Play music files from the USB device through the Sound Bar.

CONNECTING A BLUETOOTH DEVICE



The initial connection

1. Press the "BT" button on the remote, the LED indicator blinks **BLUE**.
 2. Turn on Bluetooth on the Bluetooth device (see the device's manual for more information).
 3. Select "S9920" from the list, connect it. When your Bluetooth device is connected, the LED indicator blinks **BLUE** slowly.
 4. Play music files from the device, connected via Bluetooth, through the Sound Bar.
- You cannot connect more than one Bluetooth device at a time.

Additional Bluetooth information

1. If you hear any break-up while streaming music from your device, move closer to your Sound Bar.
2. Bluetooth signal has a range of up to 30 feet (9.15 metres) if there are no solid obstructions between your Sound Bar and source device.
3. Other wireless devices may interfere with Bluetooth range, including wireless video monitors, cordless phones, wireless cameras, etc. Moving or turning off these devices may improve Bluetooth range.

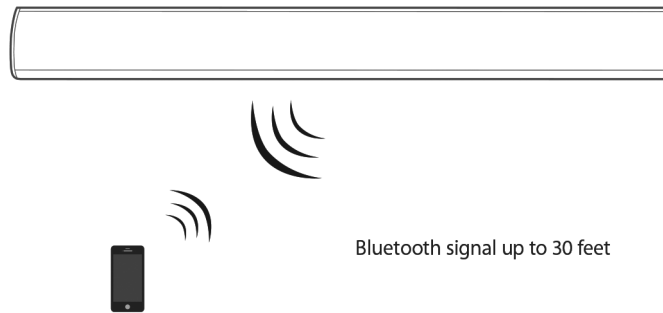

* NOTE: Reduce the volume on your device or Sound Bar, high volume can damage your hearing.

KNOW YOUR REMOTE

Power the remote by inserting 2 x AAA batteries.

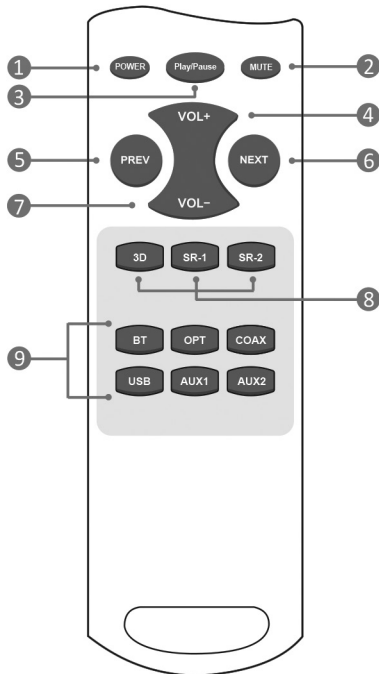

- (1) Turns the Sound Bar on and off.
- (2) Press to mute and unmute.
- (3) Press to pause or play music.
- (4) / (7) Press to adjust volume.
- (5) / (6) Press to select previous or next music file.
- (8) Three kinds of Audio Modes to select:
 "3D" mode fills your room with sound.
 "SR-1" mode gives clear sound for TV shows and News.
 "SR-2" mode provides deeper bass in movies and music.
- (9) Press to select a source (input) connected to the Sound Bar.
 "BT": Bluetooth mode, LED indicator: **BLUE**
 "OPT": Optical mode, LED indicator: **WHITE**
 "COAX": Coaxial mode, LED indicator: **GREEN**
 "USB": USB mode, LED indicator: **PURPLE**
 "AUX1": AUX1 (R/L) mode, LED indicator: **LIGHT BLUE**
 "AUX2": AUX2 mode, LED indicator: **YELLOW**

INSTALLING THE WALL MOUNT

1. Place the wall mounting template against the wall under your TV and using a pencil, mark the bracket holes.
 - The template must be level.
 - Leave at least 3 inches (76 mm) between the template and TV.

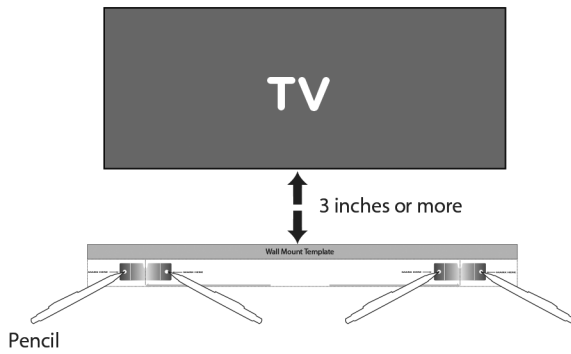

2. Remove the template and use an appropriately sized drill bit to drill a hole in the wall at each marking.
 - Be sure the wall is vertical wall (drywall).
3. Push the green Holder-Screw into each hole in the wall, and screw each screw (supplied) through each bracket firmly into a support Holder-Screws hole.



4. Install the Sound Bar by hanging the bracket on the wall.

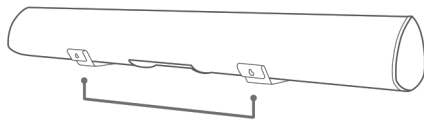

Wall Mount Equipment



Consult a professional installer if you are unfamiliar with power tools or the layout of electrical wiring in the walls of your home.

TROUBLESHOOTING

If you have a problem with your Sound Bar, there is a quick and simple solution. First, make sure:

- The cables between the Sound Bar and input devices are securely connected and the power adapter is also connected to a working power source.
- The adapter LED indicator is lit up and the LED indicator is also lit up in the middle of Sound Bar.

No sound or crackling noise:

- Check if all cables are connected properly.
- Press "MUTE" on the remote to ensure the Sound Bar is not muted.
- Press "VOL+" on the remote or the right side of your Sound Bar.
- Make sure you have selected the right input source on your remote, and the LED is lit up accordingly.
- If using Bluetooth, check that the sound on your device is not at minimum volume.
- If using Optical/Coaxial, check if your device (TV/Cable Box/Projector/etc.) audio output is set to "PCM" or turn the Dolby/DTS off.
- When using cable connection, make sure the cable is connected to an audio output on your device (not input).

Remote isn't working:

- Check that the battery is installed properly and has power.
- Make sure that the signal of the receiver is not obstructed.
- The working distance of the remote is 6-8 metres (clear space).

I hear buzzing or humming

- Ensure all cables and wires are securely connected.
- Connect a different source device (TV, Blu-ray player, etc.) to see if the buzzing persists. If it does not, the problem may be with the original device.
- Connect your device to a different input on the Sound Bar.

Bluetooth can't be connected

- Make sure the Sound Bar is not connected with a third party Bluetooth device.
- Be sure that there are no solid obstructions between the Sound Bar and source device (within 30 feet/9.15 metres)
- Reboot the Bluetooth and connect again.

Can not sync to universal remote

- The remote can only be synced to IR learning universal remotes (eg: Logitech Harmony).

Hear echo when watching TV

- Set your TV audio to External Speaker.
- Mute the TV speaker.

IMPORTANT NOTES ABOUT SERVICE

Figures and illustrations in this Manual are provided for reference only and may differ from actual product appearance.

SPECIFICATIONS

	SPECIFICATION
Model	iD-S9920-OPT
Material	High-grade ABS
Sound Bar Dimension	4.13 x 38.58 x 3.94 in
Frequency Response	50Hz-19kHz
Sound Pressure Level	105dB
Distortion	<1%
Channel	2.0
Speakers	4 x Mid-Low Frequency Drivers + 2 x Tweeters
Output	80W
STN	≥115dB
Input Power	DC 19V, 3.5A
Colour	Black
Inputs	1 x RCA Stereo Audio
	1 x 3.5mm Jack
	1 x USB
	1 x Bluetooth (Wireless)
	1 x Optical
	1 x Coaxial
Remote Control	Full function
Scope of Application	LED/LCD TV, Notebook, Smart Phone, Gaming Console
Packing	Measurements: 108 x 15 x 19 cm
	Qty: 1 Pcs/Ctn
	G.W: 6.7 kg
Accessories	User Manual, Line in Cable, Digital Optical Cable, Wall Mounting accessories, Remote Control, Power Adaptor
Compliance	UL, FCC, ROHS, CE, RCM
Country of Origin	China

*** Disclaimer:** *Instructions and specifications are correct at time of printing.
Information within may be subject to change without notice.*

WARRANTY INFORMATION – Terms of Warranty – 5 Years

Consumer Guarantees

When you purchase a National Audio Systems distributed product, you have the peace of mind in knowing that your product is covered by the NAS warranty. The NAS warranty is provided by National Audio Systems Pty Ltd (ABN 50 085 679 894), 127 Merrindale Drive, Croydon, Victoria 3136. ['NAS']

The Australian Consumer Law protects consumers by giving them certain guaranteed rights when they buy goods and services. Rights guaranteed under the Australian Consumer Law include;

- The goods are of acceptable quality;
- The goods match their description or any sample or demonstration model;
- The goods are fit for any represented purpose or purpose which the consumer has made known;
- Repairs and spare parts are reasonably available (unless notice has been provided that repairs or spare parts would not be available); and
- The services are carried out with reasonable care and skill and are completed within a reasonable time

These rights are called 'Consumer Guarantees' and apply automatically whenever goods or services are supplied to a consumer. These Consumer Guarantees cannot be refused, changed or limited.

Consumer Guarantees have no set time limit and depending on the price and quality of goods a Consumer may be entitled to a remedy after any manufacturers' or NAS's extended warranty has expired.

The Specific Warranty Table Information outlines the warranty period, warranty type and any specific exclusions for your NAS product. NAS considers the warranty period specified in the Specific Warranty Table to be a reasonable warranty period having regard to the price, design, manufacture and expected use of the product.

General Warranty ('Warranty')

NAS products come with guarantees that cannot be excluded under the Australian Consumer Law. You are entitled to a replacement or refund for a major failure or if the goods fail to be of acceptable quality. You are also entitled to have the goods repaired or replaced if the goods fail to be of acceptable quality and failure does not amount to a major failure. What constitutes a major failure is set out in the Australian Consumer Law.

Subject to the terms and conditions set out below, and unless otherwise specified in the Specific Warranty Information for your NAS product, NAS agrees to repair or replace, at NAS's cost, the NAS product purchased by you in Australia or New Zealand from NAS or a NAS authorised reseller when the product does not perform substantially in accordance with the specifications during the warranty period specified in the Specific Warranty Table for your NAS product. NAS makes no other express warranties in respect of your NAS product. To make a claim under this Warranty, valid proof of purchase must be presented when the warranty claim is made, along with any other required information. The Warranty offered by NAS is not transferable.

The Warranty will only apply if your NAS product has been installed and used in accordance with NAS's recommendations as noted in the operating instructions.

Warranty Exclusions

The Warranty does not cover damage caused by;

- Misuse or abuse of the product by You;
- Incorrect operation or not following the operation instructions (as noted in the operating instructions);
- Improper installation;
- Incorrect or improper maintenance or failure to maintain the product;
- Failure to clean or improper cleaning of the product;
- Incorrect voltage or non-authorised electrical connections;
- Adverse external conditions such as incorrect or fluctuations in electrical voltage, thunderstorm activity, acts of God, acts of terrorism, damage caused by vermin, or any other circumstance beyond NAS's control;
- Exposure to excessive heat, moisture or dampness;
- Exposure to abnormally corrosive conditions;
- Alterations or modifications to the product made by You or a third party; or
- Damage as a result of accident, liquid, grit, impact or lack of proper care as indicated in the operating instructions;
- Damage resulting from the use of cleaning solvents such as acetone

The Warranty does not apply if any serial number or appliance plate on the product has been tampered with, removed or defaced.

The Warranty does not apply if the product has been repossessed under any financial agreement.

The Warranty excludes accessories and consumable goods which have ceased working through normal wear and tear such as, but not limited to, batteries, lamps and other parts classifiable as a consumable part.

The Warranty does not cover the loss of any data howsoever caused. You shall be responsible for backing up and protecting data against loss, damage or destruction.

Products presented for repair may be replaced by refurbished products of the same type rather than being repaired. Refurbished parts may be used to repair the products. Replacement of the product or a part does not extend or restart the Warranty Term.

The product will be at the owner's risk whilst in transit to and from all NAS authorised service centres, unless transported by NAS or its authorised representatives.

NAS and its authorised service centres may seek reimbursement of any costs incurred by them when the product is found to be in good working order.

The cost of claiming under this warranty, including return of any product to NAS is to be borne by the consumer.

The Warranty excludes removal or reinstallation costs.

*** All inDESIGN products come with a 5 year warranty term.**

For further information and warranty claims, refer to our **Support** page at www.nationalaudio.com.au.