



USER MANUAL

**On-Line UPS
Model ZS110**

1000VA/2000VA/3000VA









Uninterruptible Power Supply System

1 Introduction

1. 1 Description of Commonly Used Symbols

Some or all of the following symbols may be used in this manual and may appear in your application process. Therefore, all users should read the form carefully and thoroughly.

Symbol & Description	
Symbol	Description
	Caution, danger
	Danger electric shock
	Alternating current (AC)
	Direct current (DC)
	Protective ground
	Recycle
	Do not dispose with ordinary trash



1. 2 Safety Instructions

1. Read this manual carefully and thoroughly before operation the UPS and save this manual properly for future reference.
2. Do not tear up or shatter the alarm table on the UPS and pay attention to it.
3. Please do not overload the UPS.
4. The UPS contains large capacity batteries. The case of the UPS must not be opened by untrained personnel. Otherwise, it may cause electric shock.
5. Do not short the positive and negative electrodes of battery. Otherwise, it may cause electric shock or fire.
6. Do not plunge or insert any objects into the air vents and other inlets.
7. Do not store or use the device in the following environment:
 - 1 Where there is inflammable gas, corrosive agents or heavy dust
 - 1 Where the temperature is very high or low (above 40°C or below 0°C) or the humidity is very high(more than 90%)
 - 1 Under direct sunlight or close to heating facilities
 - 1 Place of strong vibrations
8. In the event of fire occurring in the vicinity, please use dry powder fire extinguishers .The use of liquid fire extinguishing agents may cause electric shock.

2 Product Description

The ST-series is an on-line uninterruptible power supply device incorporating double-converter technology with single-phase input and single-phase output. It offers the high quality power supply with the greatest degree of availability and reliability. The 1-3kVA of ST series is compact and convenient for users, especially for the basic equipments in some areas such as: finance, communication, government, traffic, manufacture, education and so on.

2.1 System Type and Configuration

There are two types of UPS according to the battery configuration: standard type and long backup time type, each available in the following ratings: 1kVA, 2kVA and 3kVA UPS.

Table 2-1 UPS types and configurations

Type	Model	Remark
Standard	1kVA ZS110-1K	With a 1A internal charger and 3 build-in batteries of 12V/ 7AH
	2kVA ZS110-2K	With a 1A internal charger and 6 build-in batteries of 12V/ 7AH
	3kVA ZS110-3K	With a 1A internal charger and 8 build-in batteries of 12V/ 7AH
Long Backup Time	1kVAS ZS110-1K-KS	With a 7A internal charger and external battery slot.
	2kVAS ZS110-2K-KS	With a 7A internal charger and external battery slot.
	3kVAS ZS110-3K-KS	With a 7A internal charger and external battery slot.

Note: "-KS" model means Long Backup Time.

2.2 The Appearance of the UPS

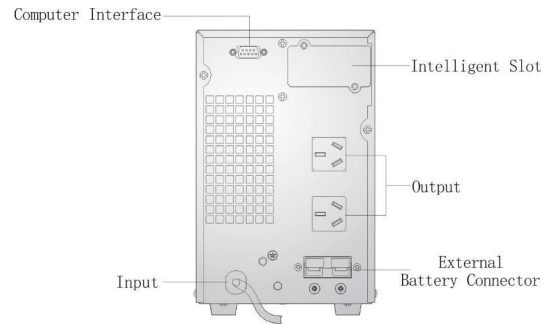

Figure 2-1 The rear panel of ZS110-1K-KS

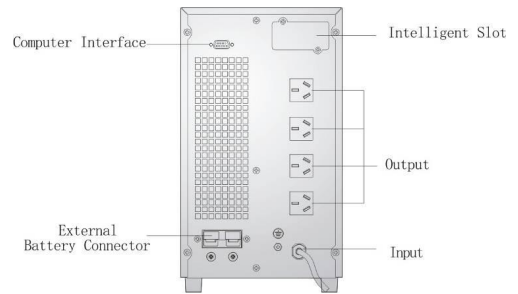

Figure 2-3 The rear panel of ZS110-2K-KS-ZS110-3K

* The picture for back panel is just for reference, it subjects to change on customer's requirement, please refer to the real subject.

Note: The appearances above are examples with the long backup time, the corresponding standard type is without the "External Battery slot".

2.3 Operating Principle

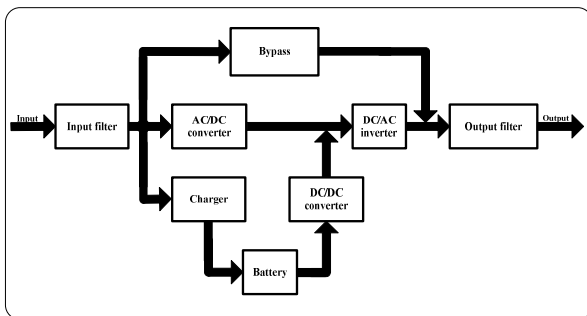

Figure 2-4 The UPS operating principle

1. Input filter: it filters the input and provides clean AC power to the UPS.
2. AC/DC converter: In Normal mode, it converts the AC input power to regulated DC power, and raises the regulated DC voltage for DC/AC converter.
3. DC/DC converter: Raises the DC Voltage from the battery system to the optimum operating voltage for the inverter when the UPS operates in Battery mode.
4. DC/AC inverter: In Normal mode, it utilizes the DC output of the AC/DC converter and inverts it into precise, regulated sine wave AC power. In Battery mode, it receives energy from the battery through the DC/DC converter.

2 Product Description

5. Bypass: It is very important in the UPS system. In the event of a UPS fault that will not lead to UPS shutdown, the load will be automatically transferred to the bypass. Meanwhile, the LED indicators will indicate

the fault type, and the fault information will be reported through the communication ports.

6. Charger: The charger of standard UPS provides 1A charging current; and long backup time provided 7A charging current.
7. Battery: Sealed maintenance-free lead –acid battery can be used as the DC source of the UPS.
8. Output filter: It filters the output and provides clean AC power to the load.

3 Installation

3.1 Unpacking Inspection

1. Open the packing box of UPS and take it out, visually examine the unit for transit damage.
2. Check against the accessory lists that the accessories of the UPS are present. (Refer to Table 9-1).
3. Make sure the model is what you wanted from the nameplate on the rear panel
4. If the UPS arrives damaged, or there is any missing accessory or other question above, please contact the distributor immediately.

3.2 Installation Notes

1. When locating the UPS, make sure there is no hazardous objects such as water, inflammable gas, corrosive agents and so on around the UPS, and that the installation environment meets the specifications.
2. The UPS should not be placed on a side. The air inlet port at the front panel and the outlet port on the rear panel and two side panels should not be blocked so as to ensure good ventilation.
3. In case if the UPS is unpacked, installed and used at very low temperatures, condensations of water drops may appear. It is necessary to wait until the UPS fully dried inside out before proceeding to installation and use. Otherwise, they may be a risk of electric shock.
4. Place the UPS near the utility power source outlet which supplies power to the UPS. In any emergency, switch off the main input socket, cut off the battery voltage input. All power sockets must be connected with ground protection.

3.3 Cable Connection

3.3.1 Connecting Input and Output Cables

1. Input cable connection

If the UPS is connected via the power cable, please use a proper socket with over current protection, and pay attention to the capacity of the socket: over 10A for ZS110-1K(-KS), over 16A for ZS110-2K(-KS) and ZS110-3K(-KS). A side of input wiring has been fixed with the UPS, and the other side is just need to plug into the input socket. The wiring configuration is shown in the following diagram.



Figure 3-1 Connection Method of Input

2. Output cable connection

The output of ZS110-1K(-KS)/ ZS110-2K(-KS)/ ZS110-3K(-KS) all available to uses sockets. The total output power shall not exceed 1kVA/0.8kW, 2kVA/1.6 kW, 3kVA/2.4 kW. Simply plug the load power cable to the output sockets of UPS to complete connection as shown in the following diagram.

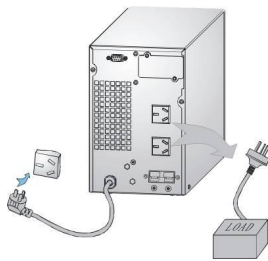

Figure 3-2 Connection method of output

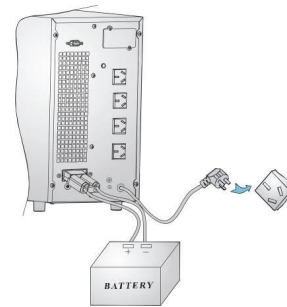

Figure 3-3 Battery connection diagram for Long Backup time models

3.3.2 Operation Procedure of External Battery for Long Backup Time UPS

The battery connection procedure is very important for long backup model. Any incompliance may result in the risk of electric shock. Therefore, the following steps must be strictly complied with.

1. First connect in series the batteries of the pack to ensure proper battery voltage that ZS110-1KS for 36VDC, ZS110-2KS for 72VDC, ZS110-3KS for 96VDC.
2. Take out the battery cable delivered with the UPS, one end of the external battery cable is a plug for connecting the UPS, the other end has 3 open wires for connecting the battery pack.
3. Connect the external battery cable to the battery terminal (DO NOT connect the battery socket of the UPS first. Otherwise, it may cause electric shock). Connect the red wire to the “+” terminal of the battery. The black wire is connected to the “-” terminal of the battery. The green/yellow wire is grounded for protection purpose.
4. Connect the plug of the external battery cable to the external battery slot on the rear panel of the UPS to complete the connection procedure.

Note: The length of the external battery cable is 1.6 m. If users need a longer one, please consult the distributor. There is a limit to the length of the external battery cable to ensure normal operation of the UPS.

3.3.3 Connecting Communication Cable

1. Computer interface

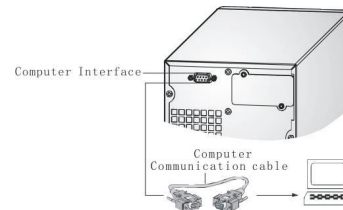

Computer interface: The type of signals is provided by the UPS to communicate with a host computer through communication cable included in the standard accessory. User can use special monitor software UPSilon in the standard accessory to monitor the UPS through the port.

2. Alternative connection of communication

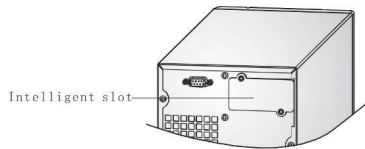

Intelligent Slot: It is designed for installing the dry contact card, SNMP card and 485 card. You can choose for one of them to installed

a—dry contact card: You can utilize monitor function of dry contact to manage the power supply directly.

b—SNMP: It enables you monitor the UPS remotely through Internet.

c —485: Central monitor card.

Note: Please remove the cover board of the intelligent slot before any card is installed.

5 Operation (LCD model)

5.1 Operation Display Panel

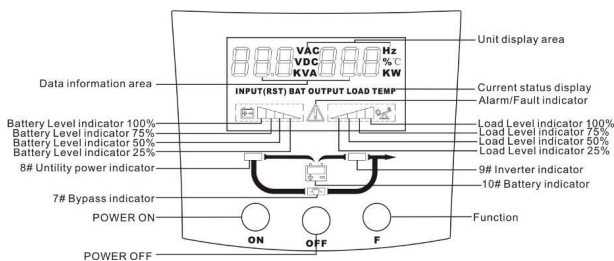

1. ON button:

Pressing the ON button more than 1 second (buzzer beeps once), the UPS system is turned on.

2. OFF button:

By pressing this button more than 1 second (buzzer beeps once) turns off the UPS system whenever the UPS run under the normal mode/battery mode.

3. Function button

The Function button provides the following functions:

a) Battery self- diagnosis: When the UPS ran in normal mode, pressing this button more than 2 seconds (buzzer beeps twice) can start the battery self-diagnosis.

b) Silence function in battery/bypass mode

In battery/bypass mode, when the buzzer beeps, pressing and holding the function button for more than 2 seconds (buzzer beeps two times) can silence the buzzer. Press the button for more than 2 seconds (buzzer beeps twice) again to resume the alarm function

c) LCD display screen switch

Pressing the function button for more than 1 seconds and less than 2 seconds (buzzer beeps once) to switch LCD display screen

4 LED indicators

The LED indicators contains, Bypass indicator, utility power indicator, Inverter indicator, Battery indicator. The definition of each indicator is the same as LED panel (refer to table 4-1).

5.2 Operation Mode

UPS Operation Mode contains normal mode, battery mode and bypass mode. Under the three modes, the page showing output voltage and output frequency is the main display page. If users need more information about UPS, Pressing the function button can initiate display screen switch. If the current page is not the main page, UPS will automatically switch back the main page after 30 seconds. In order to extend the LCD usage life, the backlight will turn off after 1 minute without any switch operation. At this point, Users just need to touch any button briefly to turn on the backlight.

5.2.1 Normal mode

When operating in the normal mode, the display of main page on the front panel is shown as the figure 5-2. The utility power indicator and the Inverter indicator are turned on. Load information area shows load value, and the battery level area indicates dynamically when the battery is not fully charged (the battery level icons lit one after another circularly). When the battery is fully charged, all the level icons are turned on.

1) If the utility power indicator blinks, it indicates that there are problems with reversed polarity (L, N) of site wiring or disconnect with ground. UPS is still working in normal mode. If the battery indicator is turned on at the same time, it shows that the voltage or frequency of the utility power is out of the normal input range of the UPS. The UPS works in battery mode.

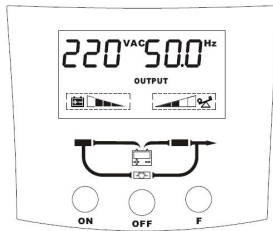

Figure 5-2 Normal Mode

- 2) If load is more than 100 percent, the buzzer beeps every second, meanwhile, the warning icon blinks every second too, reminding that UPS is overloaded. You should get rid of some unnecessary loads one by one to decrease the loads until the alarm clear
- 3) If the battery indicator blinks, it indicates that no battery is connected to the UPS or battery voltage is too low. You should check if battery is properly connected to the UPS, and press function button more than 2 seconds to start the battery self-diagnosis. If the connection between battery and UPS is confirmed without any problem, it may be due to the defect or aging of the battery, please refer to the “troubleshooting” in chapter 7 to solve the problem accordingly.
- 4) The other four display pages are load percent page, actual load page, input information page and the maximum temperature page.

Note: Connection to a power generator has to be made according to the following:

- I Activate the power generator and wait until the operation is stable before connecting the output of the power generator to the UPS (be sure that the UPS is in idle mode). Then, turn on the UPS according to the startup procedure. After the UPS is turned on, the loads are connected one by one.
- I It recommended that the capacity of the generator should double than UPS.

5.2.2 Battery Mode

When operating in the battery mode, the display of main page on the front panel is shown as the figure 5-3. The battery indicator and the Inverter indicator are turned on. If the utility power indicator blinks at the same time, it shows that the utility power is abnormal. Load information area shows load value, and bat level area shows current battery capacity.

- 1) When the UPS is running in battery mode, the alarm will beep every 4 seconds. If the “Function” key is pressed for more than 2 seconds, the alarm will not beep (silence function). Press the “Function” key more than 2 seconds again to resume the alarm function.



Figure 5-3 Battery Mode

- 2) When the battery capacity decreases, the number of battery capacity indicators turned on will decrease. If the battery voltage drops to the pre-alarm level, the alarm will beep every second to remind the user of insufficient battery capacity.
- 3) The other four display pages are load percent page, actual load page, battery information page and the maximum temperature page.

5.2.3 Bypass Mode

When operating in bypass mode set up through UPSilon software, the display on the front panel is shown as the figure 5-4, the utility power indicator and the bypass indicator are turned on. Load information area shows load value, and the battery level area indicates dynamically when the

battery is not fully charged (the battery level icons lit one after another circularly). When the battery is fully charged, all the level icons are turned on.

- 1) When operating in bypass mode, the UPS beeps every 2 minutes. If the "Function" key is pressed for more than 2 seconds, the alarm will not beep (silence function). Press the "Function" key more than 2 seconds again to resume the alarm function.
- 2) If the utility power indicator blinks, it shows that the voltage or frequency of the utility power is out of the input range of the UPS or there are problems with reversed polarity (L/N) of site wiring or disconnect to the ground for protection.
- 3) The other four display pages are load percent page, actual load page, input information page and the maximum temperature page.

Notes: When operating in bypass mode, the backup function of the UPS is not available and the power used by the load is directly from the utility power via internal EMI filter.

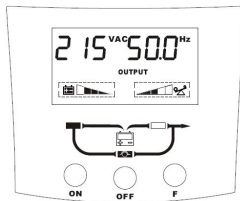

Figure 5-4 Bypass Mode

5.2.4 LCD indication of UPS alarm status and faults

In the event of an UPS fault, UPS enters fault operation mode, at this point, the fault icon turns on consistently, the buzzer beeps continuously and the data information area shows current fault code (refer to table 6-2), the display on the front panel is shown as the figure 5-5, users can switch to output page by pressing function button.

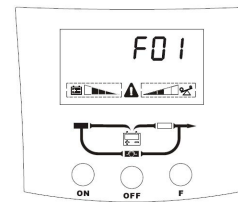

Figure 5-5 Fault display

When a warning occurred, the fault icon blinks every second, and users can switch to the alarm display page shown as the figure 5-6 to check the warning code.

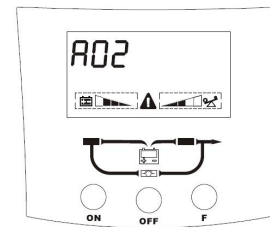

Figure 5-6 Alarm display

5.3 Operating Instructions

5.3.1 UPS ON/OFF Operation

Note: *The battery is fully charged before delivery. However, storage and transportation will inevitably cause some charge loss. Therefore, it is advisable to charge the battery for 10 hours before using it, so as to ensure adequate battery capacity.*

1. Turning on the UPS

The operation of turning on the UPS contains: turning on with utility power and turning on without utility power.

1) Turning on with utility power:

Connect the mains input to the UPS, press the ON button more than one second, UPS starts to turn on. At this point, the LCD begins to conduct self-diagnosis (all the LCD indicators are turn on about 4 seconds). A few seconds later, the UPS will begin to operate in Normal mode; meanwhile, the utility power indicator, inverter indicators will turn on. If the utility power is abnormal, the UPS will work in battery mode.

2) Turning on without utility power:

With no mains input feed to the UPS, press the ON button more than one second, ups start to turn on, At this point, the LCD begins to conduct self-diagnosis (all the LCD indicators are turn on about 4 seconds). A few seconds later, the battery indicator, inverter indicators will be turn on to indicate that the UPS is working in battery mode.

3). Powering down the UPS

The operation of powering down the UPS contains: turning off ups in normal mode, turning off ups in battery mode

4) Completely power down the UPS from Normal mode

Hold and press the OFF button persistently for more than 1 second to

power off the UPS. If it has been set up to work in bypass mode by software, the bypass indicator will be turned on to indicate that the UPS is working in bypass mode. In order to cut off the output from the UPS, simply cut off the utility power supply. LCD begins to conduct self-diagnosis (all the LCD indicators are turned on about 4 seconds), a few seconds later, not any display is shown on the front panel and no output is available from the UPS outlets, system completely power down.

5) Completely power down the UPS from Battery mode

Press the "OFF" button persistently for more than 1 second to power off the UPS. When being powered off, the LCD will start self-diagnosis (all the LCD indicators are turn on about 4 seconds), a few seconds later, not any display is shown on the front panel and no voltage output is available from the UPS outlets, system completely power down.

5.3.2 Conducting Battery self-diagnosis

In UPS operation, users can manually initiate battery self-diagnosis to check the battery conditions. There are two methods to initiate the battery self-diagnosis:

1. Through the function button

In normal mode, press and hold the function for more than 2 seconds until the buzzer beeps twice. At this point the indicators (LED7~10) will blink cyclically, indicating the UPS has worked in battery mode and the battery self-diagnosis has started. The battery self-diagnosis will last for 10 seconds default. In the event of a battery fault during battery self-diagnosis, the UPS will transfer to normal mode automatically.

2. Through the monitor software

Users can also initiate battery self-diagnosis through the background monitoring software.

6 Maintenance

6.1 Battery Maintenance

The battery is key component of the UPS. The battery life depends on the ambient temperature, charging and discharging times. High ambient temperature and deep discharging will shorten the battery life.

1. Sealed maintenance-free lead –acid battery be used in the standard.
When being connected to the utility power whether the UPS has been turned on or not, the UPS keeps charging the battery and also offers the protective function of charging and discharging.
2. Keep the ambient temperature between 15°C and 25°C
3. If the UPS has not been used for a long period, charging is recommended at the intervals 3 months.
4. Batteries should not be replaced individually.
5. Under normal conditions, the battery life lasts 3 to 5 years. In case if the battery is found not in good condition, earlier replacement should be made. The battery should only be replaced by qualified service personnel.

Note: 1. Prior to battery replacement, the UPS must be turned off and disconnected from utility power.

- 2. Metal objects such as rings and watches should be removed.*
- 3. Use the screwdriver with insulated handle. Tools and other metal objects should not be placed on the battery.*
- 4. Short circuit or reverse connection between the positive and negative terminal of the battery is strictly forbidden.*

6. 2 Checking UPS function

Every time when conducting field maintenance, please check the regular function of the UPS, including:

1. Check the operation status of the UPS
If the main voltage is within the specifications, the UPS should operate in normal mode; if the main voltage is abnormal, the UPS should operate in battery mode. In both cases, there should be no fault indication.
2. Check the transfer between the UPS operation modes
Disconnect the main input to simulate a mains failure, the UPS should transfer to battery mode and operate normally; then recover the mains input, the UPS should transfer to normal mode and operate normally
3. Check the LED indicators of the UPS
During the check processes stated above, check that the LED indication of the UPS agrees with the UPS operation mode.

7 Troubleshooting

In the event of an UPS fault, shoot the trouble according to Table 6-1. If the fault still persists, please contact our customer service center.

Faults			Possible cause	Solution
Fault/Warning code	Fault icon	Alarm		
F01	on constantly	Beep continuously	Internal fault.	Please contact the distributor or Service center
F02	on constantly	Beep continuously	Internal fault.	Please contact the distributor or Service center
F03	on constantly	Beep continuously	Internal fault.	Please contact the distributor or Service center
F04	on constantly	Beep continuously	The UPS output is short circuited	Turn off the UPS. Remove all loads. Ensure that the loads are not failed or the UPS has no internal short before turn on it again. If failed, please contact the distributor or service center
F05	on constantly	Beep continuously	Internal fault.	Please contact the distributor or Service center
F06	on constantly	Beep continuously	Internal fault.	Please contact the distributor or Service center
F07	on constantly	Beep continuously	Overload fault	Reduce the member of loads connected to the UPS.
F08	on constantly	Beep continuously	Internal overheat	Ensure that the UPS is not overloaded and the ventilation opening is not blocked and ambient temperature is not too high. Wait for 10 min. for the UPS to cool down before turning it on again. If it does not work. Please contact the distributor or service center.
F09	on constantly	Beep continuously	The charger of the UPS is defective	Please contact the distributor or Service center
A01	Blink once every second	Beep once every second	Overload pre-warning	Reduce the member of loads connected to the UPS.

25

7 Troubleshooting

Fault/Warning code	Faults		Possible cause	Solution
	Fault icon	Alarm		
A02	Blink once every second	Beep continuously	Battery overcharging	Please contact the distributor or Service center
A03	Blink once every second	Beep once every second	UPS power on abnormal	Check the battery of the UPS connected properly.
A04	Blink once every second	Beep once every second	Battery voltage low	The UPS output will be cut off, please switch to the backup power.
A05	Blink once every second	Beep once every second	Fan failure	Ensure that the fan is not locked
A06	Blink once every second	Beep once every two minutes	Maybe reversed polarity (L,N) of site wiring or disconnect with ground.	Please check the polarity of the neutral wiring and the line wiring, ensure that The green/yellow wire connect protective ground properly

Table 7-2 UPS troubleshooting of LCD panel indicator

When you contact the service center, please provide the following information:

- Model No and Serial No of the UPS.
- The date when the problem arose.
- Complete description of the problem, including the panel display, alarm warning, and power condition and the load capacity. If the UPS is a long backup time model, you may also provide the battery information.

26

8 Specifications

8.1 Electrical

Model		ZS11 0-1K	ZS110- 1K-KS	ZS11 0-2K	ZS110- 2K-KS	ZS11 0-3K	ZS110- 3K-KS	
Rating		1KVA/800W		2KVA/1600W		3KVA/2400W		
Input	Input system	Single phase & earth ground						
	Rated voltage	220VAC						
	Voltage range	115VAC~300VAC						
	Frequency	50Hz						
	Power factor	≥0.99						
Voltage range of bypass		(80±5)VAC~(286±5)VAC						
Output	Output system	Single phase & earth ground						
	Rated voltage	220VAC						
	Power factor	0.8						
	Voltage precision	±2%						
	Output frequency	Normal mode	1.The output frequency synchronizes with the input frequency when the input frequency is in the range of 46 Hz~54 Hz 2.The output frequency is 50Hz when the input frequency is not in the range of 46 Hz~54 Hz					
		Battery mode						
	Inverter overload capacity (Utility power, 25℃)	105%±5%<Load≤125%±5% 50s transfer to bypass 125%±5%<Load<150%±5% 25s transfer to bypass Load>150%±5%,300ms transfer to bypass						
	Transfer time	0ms (Normal mode↔ Battery mode) <4ms (Normal mode↔ Bypass mode)						
	Crest factor	3:1						
	Battery	Batteries voltage	36VDC		72VDC		96VDC	
Battery Quantity		3	none	6	none	8	none	
Battery Type		Sealed maintenance-free lead -acid battery of battery voltage 12V/7AH						
Backup Time (25℃)		Full load ≥5min (Standard)						
Charge current	1A	7A	1A	7A	1A	7A		

8.2 Mechanical

Model	W*H*D(mm)	Weight(kg)
ZS110-1K	144×229×350	11.5
ZS110-2K	190×328×424	24
ZS110-3K	190×328×424	28
ZS110-1K-KS	144×229×350	6
ZS110-2K-KS	190×328×424	12
ZS110-3K-KS	190×328×424	12

8.3 Environmental

Item	Normal range
Ambient temperature	0℃~40℃
Environment humidity	20%~90% (No condensation)
Altitude	Lower than 1000m: no derating Over 1000m :1% derating for every 100m rise
Storage temperature	-15 ~45

8.4 EMC

Item	Standard	Level
ESD	IEC61000-4-2	LEVEL4
RS	IEC61000-4-3	LEVEL3
EFT	IEC61000-4-4	LEVEL4
Surge	IEC61000-4-5	LEVEL4

8.5 Safety

Comply with GB4943-2001, IEC62040-1 and CE requirements.

8.6 Industry Standard

Comply with EN62040, YD/T 1095-2000 requirements.

9 Appendix

9.1 Consignment Lists

Model Type	Accessories	No
Standard Model	Machine	1
	Intelligent monitor software CD	1
	User Manual	1
	Serial communication cable	1
Long backup time Model	Machine	1
	Intelligent monitor software CD	1
	User Manual	1
	External Battery Cable	1
	Serial communication cable	1