

Aroace

GAS-FIRED DOUBLE-EFFECT ABSORPTION CHILLER-HEATER

This product is a gas-fired absorption unit which provides chilled water for cooling or hot water for heating in central plant type air conditioning systems. Units with nominal refrigeration capacities of 30, 40, 50, 60, 80, and 100 tons are complete with operating and safety controls.

When this equipment is correctly applied, installed in accordance with Yazaki INSTALLATION INSTRUCTIONS, and properly maintained, it can provide many years of trouble-free operation.

CONTENTS

GENERAL	Page	MAINTENANCE	Page
• ABSORPTION PRINCIPLE	2	• GENERAL INFORMATION	8
• COOLING OPERATION	2	• ROUTINE MAINTENANCE	8
• HEATING OPERATION	3	• MAINTENANCE INTERVALS	8
		• EVACUATION OVERVIEW	8
CONTROLS		• CHEMICAL MAINTENANCE	9
• GENERAL INFORMATION	4	• WINTER SHUTDOWN	10
• CONTROL ADJUSTMENTS	6	• TROUBLESHOOTING	10
		• WATER QUALITY	11
OPERATION		• ERROR CODES	11
• COOLING	7	• STARTUP & MAINTENANCE	
• HEATING	7	DATA SHEET	13
• SAFETY CONTROLS	7		
• REMOTE CONTROL	7	WARRANTY	
• PRECAUTIONS	7	• YAZAKI LIMITED EXPRESS WARRANTY	14

GENERAL

These instructions are intended to acquaint the Owner/End User with the operation and general maintenance requirements of Yazaki CH-K gas-fired double-effect Absorption Chiller-Heaters.

Please read ALL instructions carefully and observe precautions. Failure to operate and maintain this equipment in accordance with the OPERATING INSTRUCTIONS may

affect the equipment performance and product Warranty.

If the equipment does not operate as expected, check the Troubleshooting Guide in these instructions BEFORE calling your Yazaki Authorized Service Provider (ASP). This approach will not only save cost but also avoid any unnecessary downtime.

ABSORPTION PRINCIPLE

Yazaki absorption chiller-heaters use a solution of lithium bromide and water, under a vacuum, as the working fluid. Water is the refrigerant and lithium bromide is the absorbent.

During cooling operation, refrigerant liquid boils under the influence of a deep vacuum in the evaporator and creates a refrigeration effect which removes heat from the chilled water circuit.

The double-effect absorption cycle has two generators, one heated by a burner and the other heated by superheated refrigerant vapor. It also utilizes a condenser, an evaporator, and an absorber.

The absorber and condenser are water cooled and heat is normally rejected to a cooling tower, though ground loop is also an option.

COOLING OPERATION

High Temperature Generator (HGE)

The gas burner heats a dilute lithium bromide solution in the HE and the boiling process drives superheated refrigerant vapor and droplets of semi-concentrated solution into the primary separator. The semi-concentrated solution is pre-cooled through a heat exchanger before flowing into the LGE.

Low Temperature Generator (LGE)

Superheated refrigerant vapor from the primary separator heats the semi-concentrated solution in the LGE. Refrigerant vapor that is liberated from this solution flows into the Condenser while the fully concentrated lithium bromide solution is pre-cooled through another heat exchanger before flowing to the Absorber.

Condenser

In the condenser, refrigerant vapor is condensed on the surface of the condenser tubing bundle and latent heat, removed by the cooling water, is rejected to a cooling tower. Refrigerant liquid accumulates in the condenser and then passes through an orifice into the evaporator.

Evaporator

In the evaporator, refrigerant liquid is exposed to a substantially deeper vacuum than in the condenser due to the influence of the absorber. As refrigerant liquid flows over the surface of the evaporator tubing bundle, it boils and removes from the chilled water circuit an amount of heat equivalent to the latent heat of the refrigerant. When at design condition, the recirculating chilled

water is cooled to 44.6°F (7°C) while the refrigerant vapor is attracted to the concentrated solution dripping over the absorber tubing bundle.

Absorber

A deep vacuum in the absorber is maintained by the affinity of the concentrated solution from the LGE for the refrigerant vapor formed in the evaporator. Refrigerant vapor is absorbed by the concentrated lithium bromide solution flowing across the surface of the absorber tube bundle. The heat of condensation and dilution are removed by the cooling water and rejected to a cooling tower. The resulting dilute solution is preheated through heat exchangers before the solution pump returns it to the HGE where the cycle is repeated.

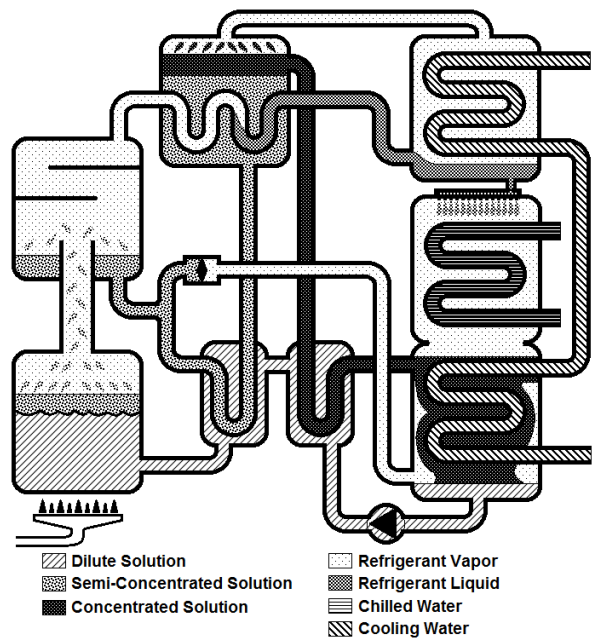

Figure 1 – DOUBLE-EFFECT ABSORPTION CYCLE (COOLING)

HEATING OPERATION

High Temperature Generator (HGE)

The solution boils in the HGE and superheated refrigerant vapor and semi-concentrated solution flow into the primary separator in exactly the same manner as in the cooling cycle.

Low Temperature Generator (LGE)

In Heat mode, the changeover valve opens a path for the semi-concentrated solution to flow out of the primary separator directly into the Absorber/Evaporator sump. Therefore, the LGE and both heat exchangers are completely bypassed while in Heat mode.

Condenser/Absorber

It is imperative that there be NO COOLING WATER FLOW in the Heat mode. As such, neither the Condenser nor the Absorber have any function in Heat mode.

Evaporator

Since the Evaporator acts as the Condenser in Heat mode, hot refrigerant vapor condenses on the surface of the evaporator coil and heat, equivalent to the latent heat of the refrigerant, is transferred to

the hot water circuit, heating it to a leaving temperature of 131°F (55°C). The condensed refrigerant drips off the evaporator and into the absorber sump where it mixes with the semi-concentrated solution, diluting it once again.

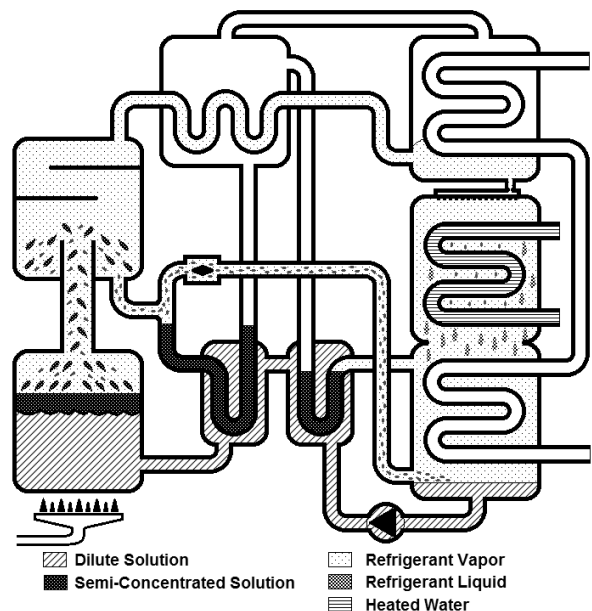

Figure 2 – DOUBLE-EFFECT ABSORPTION CYCLE (HEATING)

CONTROLS

GENERAL INFORMATION

A control panel (Figure 3) is built into each absorption chiller-heater and is located on the control box, behind the hinged, lower front-left panel. After inspecting the control panel and/or making changes to the mode of operation, make sure that the front panel closed securely to prevent rain from entering the cabinet as well as unauthorized tampering with the controls.

The chiller-heater may also be supervised and controlled by external control systems to a limited degree when the necessary interconnections are installed. Additional

controls and interlocks can be explained by your ASP.

Once COOLING or HEATING operation is selected and the unit is started, the chiller-heater will function automatically and remain in operation as long as there is a demand for chilled or hot water.

Be aware that the STOP lamp is lit anytime the unit is Disabled. The RUN lamp is lit anytime the unit is Enabled, whether or not the unit is actively running to control the chilled or hot water temperature.

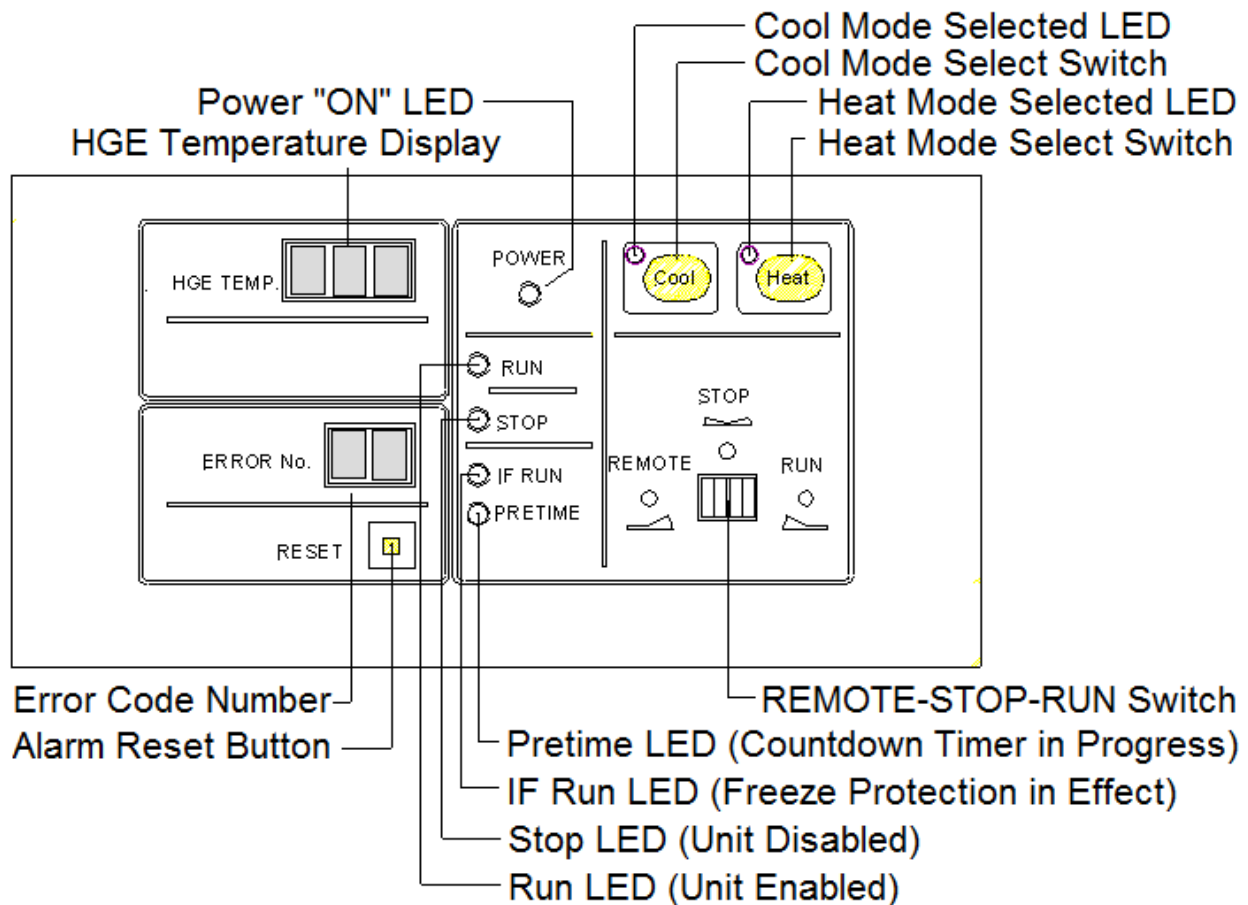

Figure 3 – CONTROL PANEL

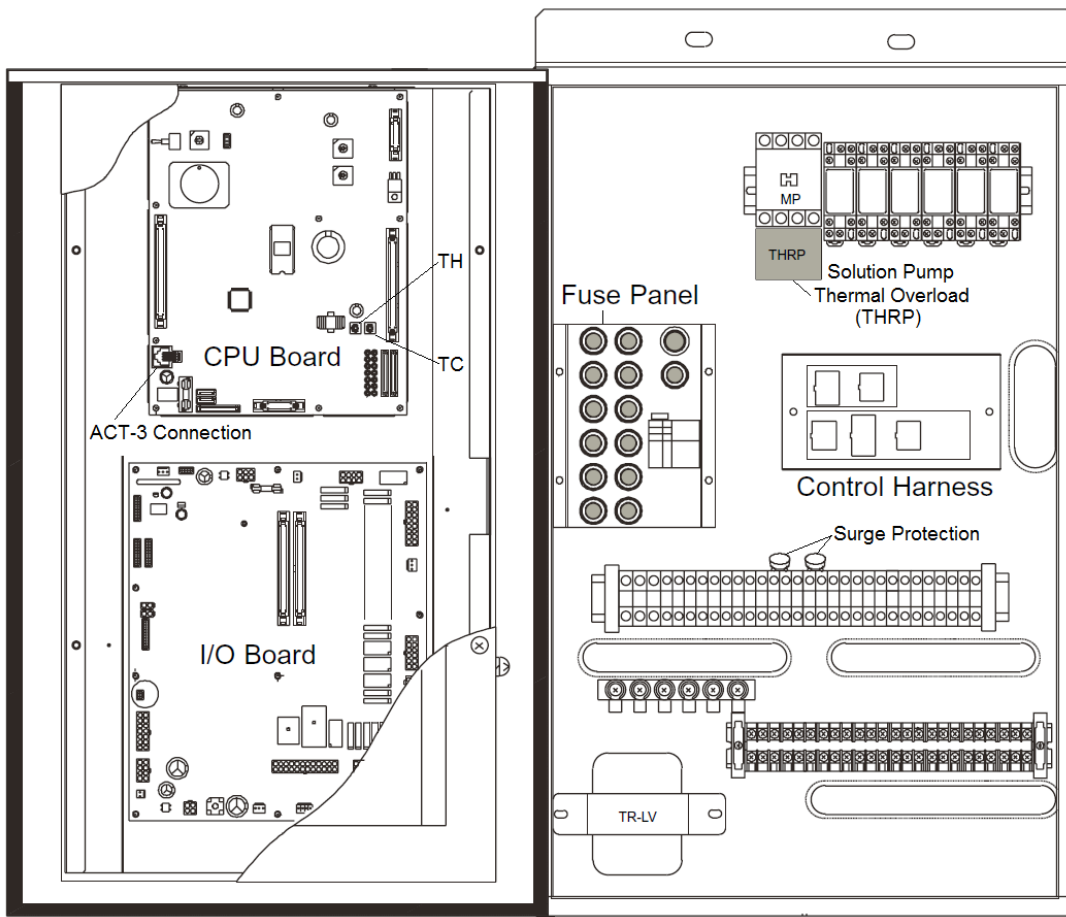
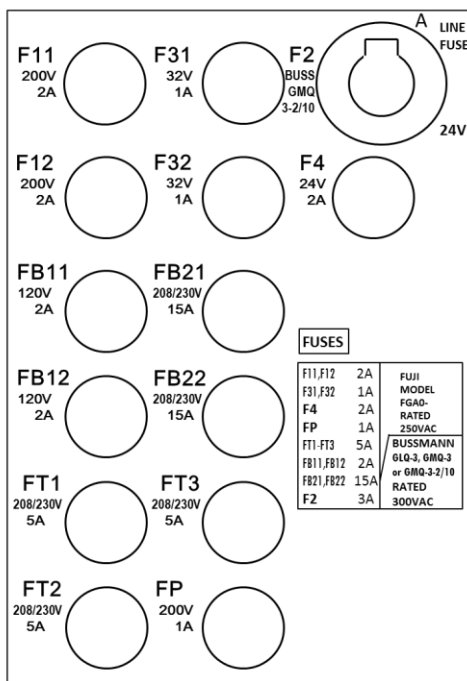
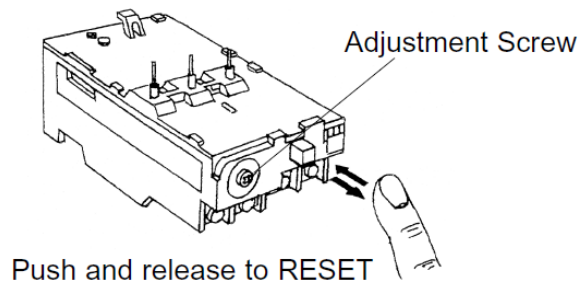

Figure 4 – CONTROL BOX LAYOUT



Fuse Rating Chart		
Symbol	Amps	Replacement
F2	3	Bussmann Model GLQ-3, GMQ-3 or GMQ-3-2/10, Rated 300vac.
F4	2	Fuji Model FGAO-2, Rated 250vac.
F11, F12	2	Fuji Model FGAO-2, Rated 250vac.
F31, F32	1	Fuji Model FGAO-2, Rated 250vac.
FB11, FB12	2	Fuji Model FGAO-2, Rated 250vac.
FB21, FB22	15	Nagasawa Model GAB
FP	1	Fuji Model FGAO-2, Rated 250vac.
FT1, FT2, FT3	5	Fuji Model FGAO-2, Rated 250vac.

Figure 5 – FUSE PANEL



Unit Size	THRP Settings (amps)	
	208v	230v
K30	3.0	2.8
K40	4.5	4.0
K50	4.5	4.0
K60	6.0	5.5
K80	6.0	5.5
K100	6.0	5.5

Figure 6 – SOLUTION PUMP THERMAL OVERLOAD

CAUTION
 FOR YOUR SAFETY DO NOT TOUCH ANY
 LIVE ELECTRICAL PARTS. ELECTRIC
 SHOCK CAN CAUSE INJURY OR DEATH.

CONTROL ADJUSTMENTS

The leaving chilled water temperature is controlled to a standard rating point of 44.6°F (7°C). The operating dead band of Low Fire is 3.6°F (2°C). The Low Fire dead band is not adjustable. The operating dead band of High fire is 7.2°F (4°C). The High Fire dead band can be cut in half by setting Dip Switch 2 on the I/O Board to ON. The leaving chilled water temperature can be adjusted using the TC potentiometer on the CPU Board. The leaving chilled water set point can be set in a range of 40.1°F (4.5°C) to 59.9°F (15.5°C).

Similarly, the leaving hot water standard rating point is 131°F (55°C). The Low Fire dead band and High Fire dead bands are identical to Cool mode, but the High Fire dead band can be cut in half by setting Dip Switch 4 on the I/O Board to ON. The leaving hot water temperature can be adjusted using the TH potentiometer on the CPU Board. The leaving hot water set point can be set in a range of 122.9°F (50.5°C) to 140.9°F (60.5°C).

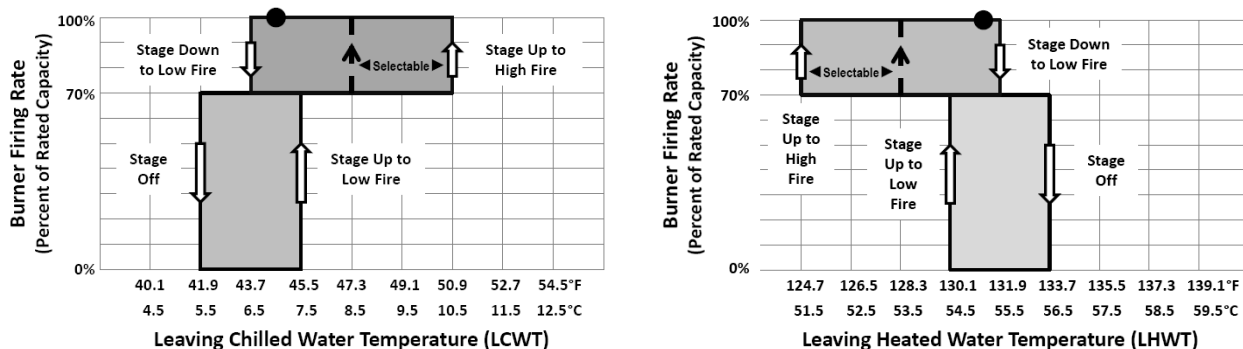

Figure 7 – TEMPERATURE CONTROL ADJUSTMENTS

OPERATION

COOLING

To engage the unit in Cool mode, press the COOL button on the Control Panel. Then choose between RUN and REMOTE setting. If the unit was not in Heat mode prior to this point, and the unit is Enabled, then the unit will engage in cool mode immediately. If, however, the unit was previously in Heat mode, the unit will engage a 30-minute mode change timer and the PRETIME light will illuminate. Once the 30-minute timer has expired, the PRETIME light will go out and the unit will engage Cool mode immediately.

HEATING

To engage a chiller-heater in Heat mode, press the HEAT button on the Control Panel. Then choose between RUN and REMOTE setting. If the unit was not in Cool mode prior to this point, and the unit is Enabled, the unit will engage in heat mode immediately. If, however, the unit was previously in Cool mode, the unit will engage a 30-minute mode change timer and the PRETIME light will illuminate. Once the 30-minute timer has expired, the PRETIME light will go out and the unit will engage Heat mode immediately.

SAFETY CONTROLS

Safety and limit controls monitor critical operating conditions within the chiller-heater and will shut down the unit when abnormal conditions arise. An Error Code that designates the cause of the shutdown (see Table 2) is displayed on the control panel. When the abnormal condition has been cleared, press the alarm RESET button to restart the cooling or heating operation. If Error Code 52 is amongst the codes being displayed, it will also be necessary to press the RESET button on the burner controller itself. If the unit does not restart, then contact your ASP.

REMOTE CONTROL

The chiller-heater can be Enabled or Disabled remotely. It can also be instructed to change between Cool and Heat modes remotely. No other remote control capability exists. To enable the unit to be controlled remotely, switch the unit into REMOTE. The unit will now Enable or Disable based on the external connection signals tied into the Junction Box.

If the unit is in RUN, the unit will ignore Enable/Disable signals from the remote signal source, but the unit will still follow remote Cool/Heat changeover commands while set to RUN.

PRECAUTIONS

1. Ensure that all AUTO-OFF-HAND switches for external pumps and the cooling tower fan are set in the AUTO position during normal operation. The chiller-heater is designed to automatically control the chilled water pump, cooling water pump, and cooling tower fan.
2. At the beginning of the cooling season clean and refill the cooling tower with fresh water.
3. During the winter season the cooling tower and cooling water circuits should be drained to avoid freezing and scaling in the absorber and condenser circuits.
4. When two or more absorption chiller-heater modules are installed in parallel, set all units for the same operating mode. Leaving water temperature set points may differ, but operating mode must always be the same.

MAINTENANCE

GENERAL INFORMATION

ALL MAINTENANCE SHOULD BE PERFORMED BY TRAINED AND EXPERIENCED PERSONNEL. Your Yazaki Authorized Service Provider (ASP) can help you establish a standard maintenance procedure.

For your safety, keep the area around the equipment clear and free of combustible materials, gasoline and other flammable substances. DO NOT obstruct service access or combustion air supply to the equipment.

ROUTINE MAINTENANCE

Routine maintenance should be provided throughout the life of the equipment to ensure satisfactory performance and operation.

During the warranty period, an ASP must be engaged to provide routine maintenance on chiller-heaters at the beginning of each

cooling season. When the chiller-heater is used for process cooling or heavy load operation it may be necessary to schedule additional service visits to evacuate non-condensable gases from the vacuum section.

MAINTENANCE INTERVALS

Every 4 months (Spring, Summer, Winter):

Evacuation (Units not used in Heat mode can skip the winter evacuation)

Every 12 months:

Burner Combustion Analysis and Gas Pressure Check (Supply and Manifold)

Inhibitor Check (If required. For the K-Series, an inhibitor charge is needed every 3 years, on average.)

Palladium Cell Heater Check

Flow Rate Check

Solution Pump Rotation Check

Flame Rod Replacement (if required)

Igniter Rod Replacement (if used and required)

Every 3 years:

HGE Inspection (pulling the burner to see the condition inside the HGE)

Average interval for Inhibitor Charge

Average interval for Flame and Igniter Rod Replacement.

EVACUATION OVERVIEW

Arguably the most important aspect of maintenance for the chiller-heater is maintaining a proper level of vacuum. Evacuation is performed at the front of the machine. The evacuation service valves are referred to as Service Valve A (upper) and Service Valve B (lower).

The evacuation service valves are back-seating access valves similar to those used throughout the refrigeration industry. The

stem has a 10mm square head. The stem secures a copper seal to a steel seat inside the valve. Do not over-torque this valve or else the seal can become damaged and compromise vacuum integrity. The proper torque is 14.75 ft-lbs (20 Nm). Yazaki offers a torque wrench (P/N N7510) specifically for use with this service valve.

A number of precautions should be observed at all times during evacuation.

***** Great care must be taken to ensure that no oil enters the Yazaki chiller-heater! Permanent damage could result from even a small amount of oil being introduced into the vacuum section! *****

- **Never** leave a vacuum pump running unattended. Power loss could allow the chiller-heater vacuum section to suck oil out of the pump in a matter of seconds.
- **Never** have the Service Valve open unless the vacuum pump is running and the integrity of the vacuum lines between the valve and the pump has been verified as tight.
- **Never** have the vacuum pump discharge tube in the water bucket unless the vacuum pump is running. The vacuum pump could suck water from the bucket and contaminate the oil charge.
- **Never** pull an extended vacuum (exceeding a few hours). If such seems to be necessary, there is likely to be something wrong with the vacuum pump or the oil has been contaminated with moisture inherently found inside the chiller-heater vacuum section.
- **Always** start with a fresh oil charge in the vacuum pump.
- **Always** use a liquid trap or collection flask.
- **Always** use a vacuum gauge to verify the level of vacuum achieved. Run time has almost nothing to do with the level of vacuum achieved.

Use only dual-stage, deep vacuum pumps. Typical refrigeration vacuum pumps

may not perform well on a vessel as large as the chiller-heater's vacuum section. Just because the vacuum pump has stopped producing bubbles in the water bucket does NOT mean the vacuum level is adequate. A digital vacuum gauge MUST be used in order to determine the true level of vacuum achieved.

The desired level of vacuum on a machine that is not running would be less than 2000 microns (<2 mmHg), with less than 1000 microns (<1 mmHg) preferred. On a machine actively running in Cool mode (currently attempting to satisfy chilled water loop load), the desired level of vacuum is 4000-5000 microns (4-5 mmHg), no less. Any lower than that on a running machine can cause the vacuum pump to remove an extraordinary amount of refrigerant vapor (water).

A step-by-step, detailed evacuation method is provided in the Service Manual. The general evacuation assembly setup is displayed in Figure 9.

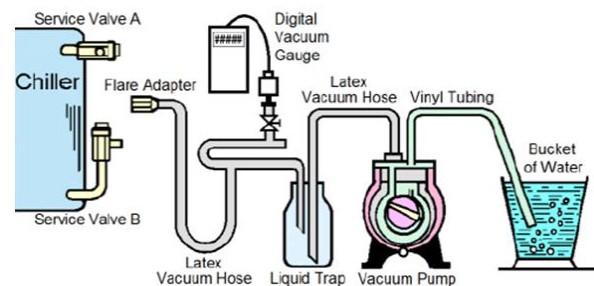

Figure 9 – GENERAL EVACUATION ASSEMBLY SETUP

CHEMICAL MAINTENANCE

It is not necessary to perform regular chemical maintenance on the Yazaki chiller-heater itself.

The chemical balance has been established in the factory during run testing. Normally, the only chemical that must be maintained is the inhibitor charge. By capturing non-condensable gases,

comparisons can be made to determine if the normal hydrogen byproduct is being produced at anticipated rates. If more hydrogen is being produced than anticipated, a maintenance inhibitor charge may need to be introduced into the machine by the ASP. An inhibitor charge is typically needed every three (3) years in Yazaki gas-fired chiller-heaters.

SHUTDOWN

The fluids within the chiller-heater itself need no preparation for freezing conditions. Only the fluids in the chilled water and cooling water circuits need to be addressed during potentially freezing conditions.

When the equipment is located outdoors in climates subject to freezing, cooling water should be drained from the chiller-heater, fluid circuit piping, and cooling tower at the end of the cooling season. Use glycol of adequate concentration in the chilled water and heat medium circuits to prevent freeze damage. The glycol will reduce the cooling and heating capacity but this may be offset somewhat by increasing the circuit fluid flow rate. If in doubt about potential freeze damage in your area, discuss it with your ASP. Damage to the unit due to freezing is not covered by the product warranty.

If a unit is to be shut down for the winter, but no fluid circuits are to be drained, then simply Disable the chiller-heater and allow the unit to complete its Post Dilution Cycle. Once completed, it is safe to leave the unit as it sits for the off-season. Take

appropriate measures to ensure the fluids in all fluid circuits are protected from freezing (glycol, heat tape, etc.).

If a chiller-heater is to be shut down long-term, then fluid circuits should be drained. Disable the chiller-heater and allow the unit to complete its Post Dilution Cycle. Once completed, turn off the breaker on the unit control panel. Then drain each fluid circuit. Once drained, make sure to blow in both directions through each circuit with compressed air (or similar) to make sure no significant amount of liquid remains inside them. Close all isolation valves so as to isolate the unit from the rest of the respective fluid circuit. Pressurize each fluid circuit in the chiller-heater with dry nitrogen to a pressure of 1-2 PSI (7-14 kPa) to help inhibit corrosion in the circuit during storage. It may be desirable to break the vacuum in the chiller-heater itself as well. If doing so, pressurize the unit to the same pressure as the circuits using nitrogen. See the Service Manual for further details.

TROUBLESHOOTING

SYMPTOM: Chiller-heater does not operate.

Possible Cause	REMEDY
No High Voltage	Check the LED for the Power indication on the Control Panel. If it is not illuminated, check the main power disconnect, fuses, and breakers.
Solution Pump Not Running	Check the THRP overload switch. Check the GP temperature. Until the GP temperature rises above 190°F (88°C), the solution pump may remain off until the GP temperature warms up.
Chiller-heater is not running but WTO temperature is above set point.	Nothing may be wrong. If the system chilled water loop has satisfied by reaching the desired set point, the unit will shut down until the WTO sensor reads a temperature 3.6°F (2°C) above the set point temperature, no matter how long that may take. To force operation, turn off power to the chiller-heater, leave power off for 10 seconds, and then restore power. The chiller-heater should start up if the WTO sensor reading is above the set point.

SYMPTOM: Poor cooling capacity.

Possible Cause	REMEDY
Poor Vacuum	Evacuate the machine per normal maintenance procedure. A leak check may also be necessary.
High Inlet Cooling Water Temperature	Check the cooling tower fan. Check the cooling tower fluid level.
Low Cooling Water Flow Rate	Check the cooling tower sump and cooling water circuit strainers.
Condenser/Absorber Fouling, Scale Buildup	Check the cooling water circuit strainers. A chemical de-scaling procedure will be necessary.
Everything appears normal but the leaving chilled water temperature is too high.	Nothing may be wrong. If the load of the chilled water circuit exceeds the capacity of the chiller-heater, the system will find equilibrium at a higher leaving chilled water temperature. If the temperature drop through the chilled water loop is approximately 8-12°F (4-6°C), then the unit may actually be giving its full capacity and its capacity simply may not be enough. Check for reasons that the load may have artificially increased (open doors, new equipment, leaking valves, etc.)

WATER QUALITY

It is the End User's responsibility to have the cooling water analyzed and chemically treated as often as necessary so that it conforms to the

limits specified in Table 1. The water quality in the chilled water, cooling water, and heat medium circuits shall not exceed the following limits:

ITEM		CHILLED WATER	COOLING WATER	MAKE-UP WATER
Standard	pH (at 77°F)	6.8 - 8.0	6.5 - 8.2	6.8 - 8.0
	Conductivity ($\mu\text{S}/\text{cm}$ at 77°F)	400	800	300
	Chloride ion (Cl^- ppm)	50	200	50
	Sulfate ion (SO_4^{2-} ppm)	50	200	50
	M-alkalinity (CaCO_3 ppm)	50	100	50
	Total hardness (CaCO_3 ppm)	70	200*	70
	Calcium hardness (CaCO_3 ppm)	50	150	50
	Ionic silica (SiO_2 ppm)	30	50	30
Reference	Total iron (Fe ppm)	1.0	1.0	0.3
	Copper (Cu ppm)	1.0	0.3	0.1
	Sulfide ion (S^{2-} ppm)	ND	ND	ND
	Ammonium ion (NH_4^+ ppm)	1.0	1.0	0.1
	Residual chlorine (Cl ppm)	0.3	0.3	0.3
	Free carbon dioxide (CO_2 ppm)	4.0	4.0	4.0
	Ryzner stability index	-	6.0 - 7.0	-

NOTES:

1. ND (Not Detectable)
2. *Total hardness of make-up water shall not exceed 70 ppm when bleed off is the only method used to control water quality.

Table 1 – WATER QUALITY REQUIREMENTS

ERROR CODES

Error Code Number	Error Description	Notes	Reset Type
FS	Flow switch alarm	Chilled/hot water flow switch FS1 open, but for less than 10 minutes. After 10 minutes, this changes automatically to error code 27.	Auto
01	DCP power error	Optional AroTrend remote monitoring package has lost power.	Auto
02	DCP communication line short	Power available to the optional AroTrend remote monitoring package but communications line is shorted.	Auto
03	DCP communication line noise	Optional AroTrend Remote monitoring package cannot communicate with the chiller-heater.	Auto
04	Accessory error	Optional fire safety shutdown.	Manual
05	Chilled/hot water pump interlock error	Voltage signal from terminal CM2 in the junction box is not returning to terminal 3 in the junction box.	Manual
06	Cooling water pump interlock error	Voltage signal from terminal CM2 in the junction box is not returning to terminal 4 in the junction box.	Manual
07	Cooling tower fan interlock error	Voltage signal from terminal CM2 in the junction box is not returning to terminal 5 in the junction box.	Manual
08	Solution pump error	Solution Pump overload THR1 has tripped.	Manual
09	Generator (HGE) over heat error	The GP sensor has reported a temperature in excess of 325.4°F (163°C). Unit locks out.	Manual
10	Generator (HGE) temp error	GPSC has opened. Unit locks out.	Manual

12	Generator (HGE) solution level error	GLS reports open. Ignored for the first 30 seconds and ignored after 20 minutes of operation. Unit locks out.	Manual
13	WTO sensor error	WT sensor reads below 14°F (-10°C) or above 212°F (100°C).	Auto
18	Seismic switch error	Optional seismic switch is open when it should be closed.	Manual
20	Cooling water scale alarm	CND - CTO > 7.2°F (4°C)	No Reset Required
21	Cooling water scale error	CND - CTO > 12.6°F (7°C)	Manual
25	High cooling water temperature	Cooling water above acceptable temperatures: CTO above 108°F (42°C) for 3 consecutive minutes.	Auto
26	Generator (HGE) over heat in heating mode	GPSH has opened. Unit locks out.	Manual
27	Chilled/hot water flow switch error (FS1)	FS1 open when it should be closed. Condition has existed for more than 10 minutes.	Auto
28	Cooling water flow switch error (FS2)	Optional cooling water flow switch (FS2) open when it should be closed. Condition has existed for more than 10 minutes.	Auto
29	CTO sensor error	CTO sensor reads below 14°F (-10°C) or above 212°F (100°C). Ignored for first 10 minutes of P2 operation.	Manual
32	GP sensor error	GP sensor reads above 338°F (170°C). Unit locks out.	Manual
33	CTI sensor error	CTI sensor reads below 14°F (-10°C) or above 212°F (100°C). Ignored for first 10 minutes of P2 operation.	Manual
36	CND sensor error	CND sensor reads below 14°F (-10°C) or above 212°F (100°C).	Auto
40	Loss of cooling capacity	LT temperature reading has not fallen below 59°F (15°C) within 30 minutes.	Manual
41	Cooling mode interrupt error	CIR contacts open for 20 consecutive seconds when they should be closed.	Manual
42	Heating mode interrupt error	HIR contacts open for 20 consecutive seconds when they should be closed.	Manual
43	Low cooling water temperature	CTI sensor reads below 46.4°F (8°C) at start of operation, or has dropped below this limit for 2 consecutive minutes during operation. Burner shuts down. P1 and P2 continue to run. Burner starts up again once CTI sensor rises above 48.2°F (9°C).	Auto
44	Changeover valve error	Changeover valve end switch has not closed within 22 seconds.	Manual
52	Combustion system error	Burner Controller indicates an alarm condition.	Manual
72	LT sensor error	LT sensor reads below 14°F (-10°C) or above 212°F (100°C).	Manual
88	Circuit Board Error	Either the CPU Board or the I/O Board or both are not responding. All functions frozen.	Not Possible
93	Model setting error	DS1 and DS3 settings are incompatible	Manual
94	TS1 Position Error	Unit left in BC or VC test mode without interaction longer than 30 minutes.	Auto
95	Data Error	CPU board requires reboot or replacement.	Manual

Table 2 - ERROR CODES



Project Name: _____
Project Address: _____

ASP Contractor: _____

ASP Technician: _____

Chiller-Heater Model #: _____
Chiller-Heater Serial #: _____

Date of Service: _____

(Fill out as completely as possible. Please write legibly.)

Type of Service:

- Start-Up
- Seasonal Changeover
- Preventive Maintenance
- Service Call
- Unit Calling For Operation

Machine Vacuum Condition:

Amount of Non-Condensables Removed: _____
 Hydrogen Present in the Removed Gas? _____
 Inhibitor Added? _____
 Palladium Cell Heater Operational? _____
 Level of Vacuum (mmHg): _____

ACT-3 Input Readings:

FS1 _____
 CVRC _____
 CVRH _____
 ESC1 _____
 ESH1 _____
 ESON _____
 ESOF _____
 PID _____
 THR1 _____

ACT-3 Output Readings:

SV2 _____
 SV9 _____
 SV1 _____
 LOW _____
 CVR _____
 HIGH _____
 RCM _____
 RBH _____
 BCN _____
 BLW _____

BCN _____
 BLW _____
 CHSTN _____
 P1 _____
 P2 _____
 SPON _____
 CHD _____
 SIG14 _____
 SIG15 _____
 SIG16 _____

ACT-3 Temperature Readings:

LT _____
 CND _____
 WTO _____
 CTI _____
 CTO _____
 GP _____
 TC _____
 TH _____

Water Circuits:

Chilled/Hot Water: _____
 Cooling Water: _____

Pressure Drops

Specified	Actual
_____	_____
_____	_____

Flow Rates

Specified	Actual
80-120%	_____
100-120%	_____

Water Pressure

at Inlet (85# max)

Electrical:

	Volts (to G)	Amps
L1	_____	_____
L2 (high leg)	_____	_____
L3	_____	_____

_____ Breaker/Fuse Size
 _____ Wire Size
 _____ SP Rotation Checked

Burner Data:

Gas Supply Pressure: _____
 Manifold Pressure: _____
 Flame Signal: _____
 Stack Draft (in. wc.): _____
 Stack Temperature: _____
 O2%: _____
 CO%: _____
 CO2%: _____
 Gas Meter Clock Time: _____

Pilot Data

Specified	Actual
Pilot/2.5" w.c.	_____
4-5 vdc	_____
-0.05 to 0"wc.	_____
_____	_____
_____	_____
_____	_____
_____	_____
_____	_____

Low Fire Data

Specified	Actual
3-4" w.c.	_____
4-5 vdc	_____
-0.05 to 0"wc.	_____
320-360°F	_____
4 - 7%	_____
0 - 200 ppm	_____
8.5 - 10%	_____

High Fire Data

Specified	Actual
3-4" w.c.	_____
4-5 vdc	_____
-0.05 to 0"wc.	_____
380-420°F	_____
4 - 7%	_____
0 - 200 ppm	_____
8.5 - 10%	_____

Electrical Connections Made in Junction Box:

- P – CM1 (Chilled/Hot Water Pump Motor Dry Contact)
- CP – CM1 (Cooling Water Pump Motor Dry Contacts)
- CTF – CM1 (Cooling Tower Fan Motor Dry Contacts)
- 3 – CM2 (Chilled/Hot Water Pump Overloads, Powered Contacts)
- 4 – CM2 (Cooling Water Pump Overloads, Powered Contacts)
- 5 – CM2 (User-Defined Alarm Contacts, Powered Contacts)

Dial & Dip Switch Positions:

DS1: _____ }
 DS2: _____ } on
 DS2: _____ }
 DP1-1: _____ }
 DP1-2: _____ } on

NOTES: _____

Please send a copy of any maintenance data sheets to Yazaki Energy Systems, Inc., at the address, FAX number, and/or email address listed on the last page of this document.

WARRANTY

YAZAKI LIMITED EXPRESS WARRANTY

1. **SCOPE OF COVERAGE.** The Limited Express Warranty of Yazaki Energy Systems, Inc. ("YESI") applies to the initial retail purchaser and assigns ("CUSTOMER") of Yazaki double-effect chiller-heaters and water-fired chillers and chiller-heaters ("PRODUCT") installed in the U.S.A., Canada, and all other countries within the YESI sales territory at the time of sale of the PRODUCT. The initial retail purchaser may assign its rights under this Limited Express Warranty to any third party with prior written consent by YESI which shall not be unreasonably withheld by YESI.

2. **GENERAL EXPRESS WARRANTIES.** YESI warrants to the CUSTOMER, that the PRODUCT shall be free from defects in material and workmanship which are discovered and reported in writing to YESI within the period of one (1) year ("Original Warranty Period") from the time when the PRODUCT is initially placed into operation at the CUSTOMER's facility ("Start-Up Date"), or two (2) years from the date of manufacture, whichever expires first, and subject to the disclaimers and limitations of this Limited Express Warranty.

As a condition of this Limited Express Warranty, the CUSTOMER shall arrange at its own cost for annual routine maintenance of the PRODUCT, prior to cooling operation and prior to heating operation of the PRODUCT, by a service provider authorized by YESI, in accordance with the Yazaki Operating and Maintenance Instructions.

This is not a warranty of performance, but a limited warranty as to the condition of the PRODUCT at the Start-Up Date.

3. **DISCLAIMER AND LIMITATION OF EXPRESS WARRANTIES.** There are no express warranties other than those contained in this Limited Express Warranty.

4. **WARRANTY REGISTRATION CARD.** Every new PRODUCT is accompanied by a Warranty Registration Card which shall be completed, signed by an authorized representative of the CUSTOMER, and returned to YESI. This Limited Express Warranty shall not apply unless the Warranty Registration Card is fully completed and returned to YESI within thirty (30) days of the Start-Up Date of the PRODUCT.

5. **WARRANTY SERVICE.** All routine maintenance, parts replacement, and vacuum section repairs of the PRODUCT during the Original Warranty Period must be performed by a service provider authorized by YESI.

To obtain warranty service, contact:

- a. The Service Provider indicated on the Warranty Registration Card, or if that person is not available;
- b. YESI's Distributor or Sales Representative from whom the PRODUCT was purchased, or if that person is not available;
- c. Yazaki Energy Systems, Inc.

6. **REMEDY DURING ORIGINAL WARRANTY PERIOD.** YESI shall, at its sole discretion, repair or replace the PRODUCT or parts thereof which YESI shall determine upon examination to be defective or not in conformity with the Original Warranty contained herein ("Defective Part"), subject to the terms hereof. YESI shall supply by standard ground transportation all parts required to repair or replace any Defective Part and shall pay the authorized service provider the necessary and allowable labor charges as fixed in YESI's warranty service payment schedule in effect from time to time ("Fixed Labor Charges"). The CUSTOMER shall be solely responsible for all labor costs or charges in excess of the Fixed Labor Charges. A

copy of the current Fixed Labor Charges for warranty service can be obtained by an authorized service provider upon written request to YESI.

7. **LIMITATION OF WARRANTY AND LIMITATION OF REMEDY.** CUSTOMER's remedies shall be limited (even in the event of YESI's default of its warranty obligations) exclusively to those provided in section 6 of this Limited Express Warranty. UNDER NO CIRCUMSTANCES SHALL YESI BE LIABLE FOR CONSEQUENTIAL OR INCIDENTAL DAMAGES. If the limitation of liability fails the essential purpose, CUSTOMER's liability shall be expanded to the minimum extent to avoid failure of the essential purpose. Customer waives any cause of action or theory of liability including, but not limited to, those arising under contract, tort, strict liability, product liability, statutes, or otherwise, except as specifically provided by the UCC as modified and limited herein. The warranty period of all replacement parts and PRODUCTS shall be deemed to commence on the Start-Up Date of the original PRODUCT, not the installation date of the replacement part or PRODUCT, and YESI's warranty obligation hereunder shall not be extended by virtue of such replacement.

8. **DISCLAIMER OF IMPLIED WARRANTIES.** YESI DISCLAIMS ALL IMPLIED WARRANTIES (OTHER THAN GOOD TITLE) INCLUDING, BUT NOT LIMITED TO, THOSE OF FITNESS FOR A PARTICULAR PURPOSE, MERCHANTABILITY, AND NON-INFRINGEMENT. There are no warranties which extend beyond those express warranties contained in this Limited Express Warranty. CUSTOMER affirms that it has not relied upon YESI's skill nor judgment to select or furnish PRODUCT for any particular purpose. YESI does not warrant that the PRODUCT complies with the requirements of any safety or environmental code or regulation of any federal, state, municipality, or other jurisdiction beyond the specific express warranties in this Limited Express Warranty.

9. **SPECIFIC EXCLUSIONS.** In addition to all other exclusions contained in this Limited Express Warranty, YESI's warranty shall also not apply under the following circumstances:

- a. Damage to the PRODUCT caused by an un-authorized service provider;
- b. Defect in any part not supplied or authorized by YESI;
- c. Installation or operation of the PRODUCT in any way not described in the applicable Yazaki Installation and Operating Instructions;
- d. Applications for process cooling (except single-effect absorption chillers);
- e. Failure to provide routine maintenance of the PRODUCT by a Yazaki-authorized service provider in accordance with the applicable Yazaki Operating and Maintenance Instructions;
- f. Failure to maintain the quality, flow, and supply temperature of the cooling water in accordance with Yazaki standards and limitation;
- g. Damage caused to the PRODUCT from freezing, overpressure, and corrosion in any water circuit;
- h. Misuse, abuse, negligence, accident, natural disaster, alteration, misapplication, or experimental use of the PRODUCT;
- i. Normal fading and minor deterioration of the cabinet surface caused by exposure to the elements;
- j. Removal of the PRODUCT from its original installation site unless the relocation is approved in writing by YESI prior to the act of relocation;
- k. Materials, such as inhibitor and batteries, that are consumed during normal operation of the PRODUCT;
- l. Damage to other products outside the PRODUCT, not supplied by YESI, caused by use of materials that are not compatible with the operating characteristics of the PRODUCT, regardless of the absence of specific instructions in Yazaki Installation and Operating Instructions.

YAZAKI AUTHORIZED SERVICE PROVIDER



For information concerning service, operation
or technical assistance, please contact your
Yazaki Authorized Service Provider or the following:

YAZAKI ENERGY SYSTEMS, INC.
701 E PLANO PKWY, SUITE 305
PLANO, TEXAS
75074-6700

Phone: 469-229-5443

Fax: 469-229-5448

Email: yazaki@yazakienergy.com

Web: <http://www.yazakienergy.com>



This symbol on the product's name plate means it is listed by
UNDERWRITERS LABORATORIES, INC.

Yazaki reserves the right to discontinue, or change at any time,
specifications or designs without notice and without incurring obligations.