

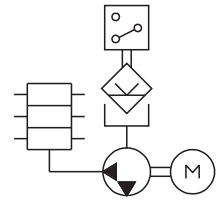

- Subject to modifications -



Pump aggregate GMG-B



Use:

As pump aggregate in central lubrication systems

- for the delivery of oil, liquid grease or grease
- 1 or 2 pump outlets
- up to 20 outlets with progressive distributor flanged-on
- electric control and monitoring
- with function stirring without delivery

Technical data:

Admissible delivery pressure: at max. 250 bar

Number of pump elements: at max. 2

Delivery volume per stroke and element
 with pump element 08: 0,08 cm³
 with pump element 16: 0,16 cm³

Temperature range: -20 ... +60 °C
 At low temperatures, grease penetration needs to be observed.

Mounting position: vertically

Material
 Casing: Aluminium
 Pump element: Steel
 Reservoir: Steel / Polyamide transparent
 Gaskets: NBR (Perbunan)

Medium: Oil and grease up to NLGI class 2
 (Mind conditions of use of both the reservoir and filling level monitoring device!)

Drive:
 Mains voltage: 24 VDC
 Current at max.: 2,5A
 Speed (load-dependent): approx. 30 min⁻¹
 System of protection: IP 55
 (Depending on type of construction, the DC gear motor should only be used in pulse mode. For other modes of operation, three-phase current motors are of advantage (e.g. Pump aggregate GMA-C).)

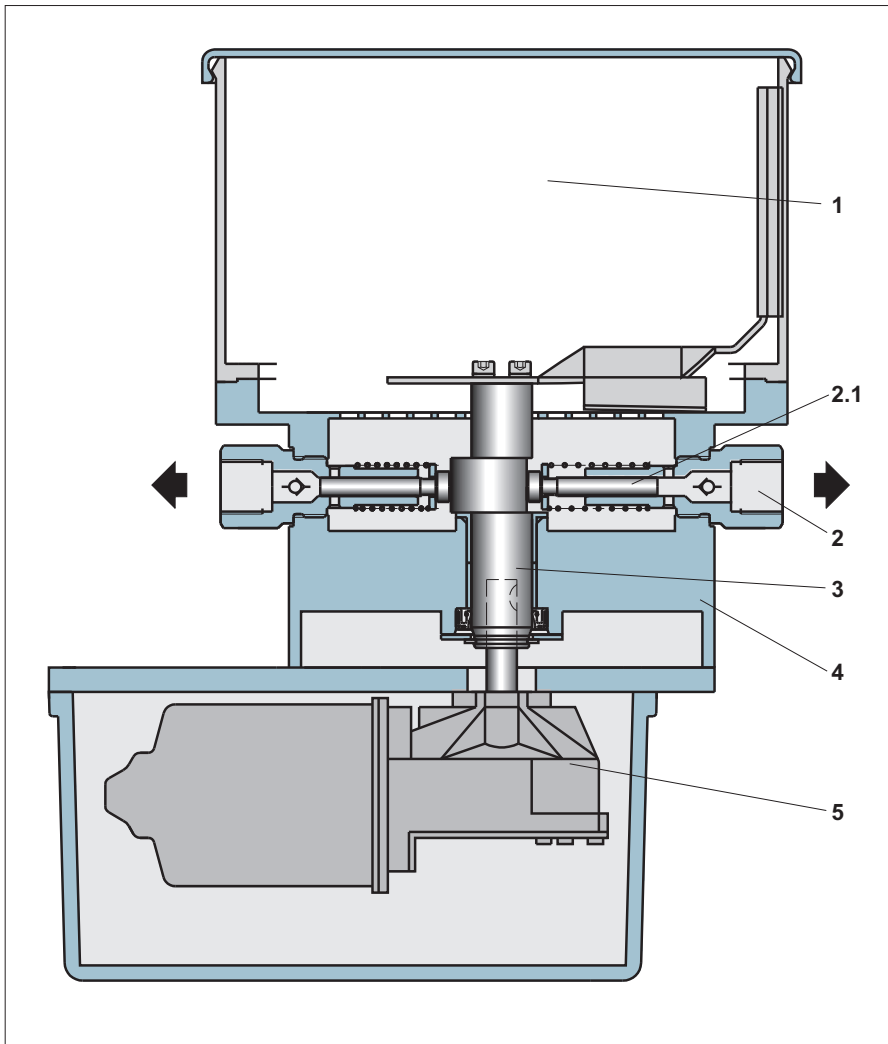

Description:

Drive:

The pump aggregate GMG-B is driven by a gear motor 5 flanged to the pump casing 4 from downside.

Delivery function:

When the eccentric shaft 3 rotates, the delivery piston 2.1 of every pump element makes a suction and delivery stroke per rotation each, whilst delivering lubricant from the reservoir 1 to the lubrication points.

Depending on the case of operation (lubricant, lubricant requirement, etc.), the pump aggregate can be fitted with different pump elements, reservoirs, and monitoring elements.

Function stirring without delivery:

In some modes of operation, improvement of lubricant quality and delivery behaviour requires the lubricant to be stirred additionally.

Such stirring is facilitated in the pump aggregate GMG-B by means of a specifically designed eccentric drive.

When the eccentric shaft 3 rotates into the one direction of rotation, the pump elements are operating while the stirring device supplies them with the lubricant.

As soon as the eccentric shaft 3 starts to rotate into the other direction, the lubricant is stirred without any delivery operation by the pump elements taking place.

The integrated control unit allows operating and off-duty periods for both the delivery with and without stirring to be programmed independently from each other.

Pump elements:

At **suction stroke**, the pressure spring 2.2 moves the delivery piston 2.1 against the eccentric shaft 3. Concurrently, the lubricant available in the reservoir 1 is drawn through the suction hole 2.3 into the metering chamber 2.4.

At **delivery stroke**, the eccentric shaft 3 shifts the delivery piston 2.1. At the same time, the suction hole 2.3 is closed up and the lubricant volume available in the metering chamber 2.4 delivered through the check valve 2.5 to the outlet 2.6.

The 0,16 cm³ delivery volume pump element is marked by a black ring R.

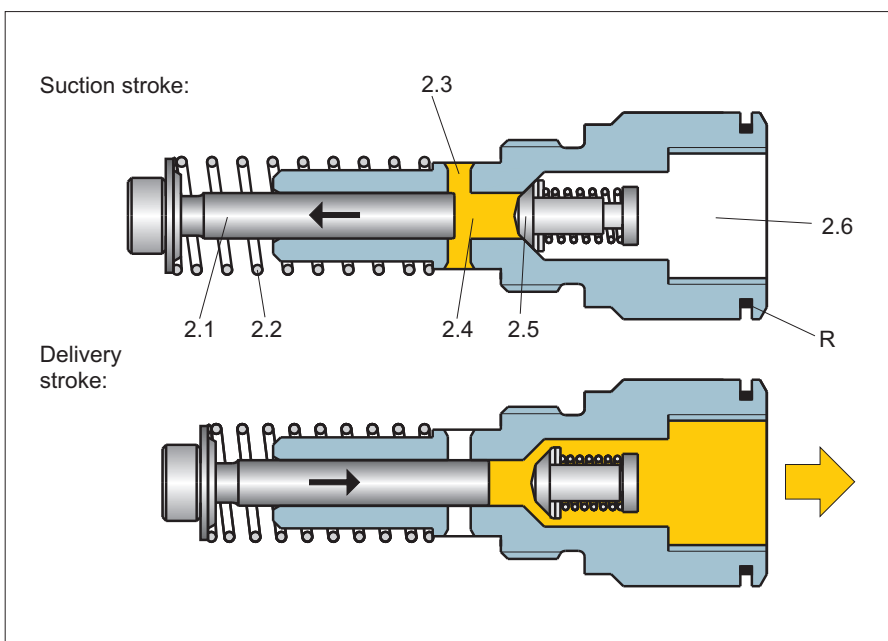

- Subject to modifications -



Notes on operation:

The pump aggregates must be operated with clean oil or grease from original packages only. During start-up, the pump has initially to be filled with gear oil up to stirring blade level. Thus, proper venting is ensured. The lines to the lubrication points

must be clean and have free throughput. They shall not be connected to the lubrication points unless the lubricant comes out free of bubbles. All connectors of the delivery line have to be checked for leakage.

To protect the pump aggregate and the lines connected from overload, protective elements such as pressure control valves have to be integrated basically.

Level control:

**Level control "C":
min. level monitoring for grease**

In case of empty reservoir and rotating pump drive shaft, the contact is switched.

The "Empty" signal is intermittent.

The switching mechanism may shift as for instance during reservoir filling. In case of external control, signal evaluation must therefore be delayed when the pump is switched on (approx. 5 seconds).

Version without control:

When "stirring without delivery", signal evaluation has to be suppressed.

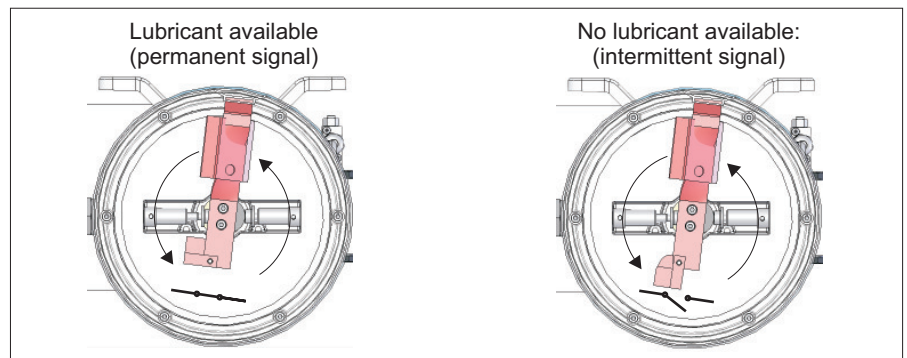

**Level control "F":
min. level monitoring for oil**

The level control "F" consists of a float that is lifted in the oil.

If oil falls below minimum filling level, the contact opened.

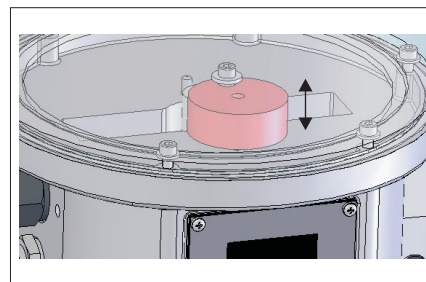

Technical data:

Temperature range: 0 ... +60 °C
 Switching voltage at max.: 30 VDC
 Switching current at max.: 0,25 A
 Switching power at max.: 3,0 W
 For inductive and capacitive loads protective circuits (diode, RC-member, varistor) have to be provided for.

Filling connector:

This part is located beneath the left-side pump element.

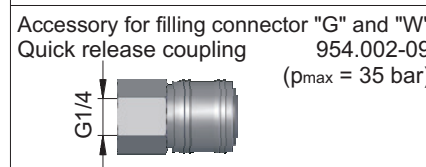
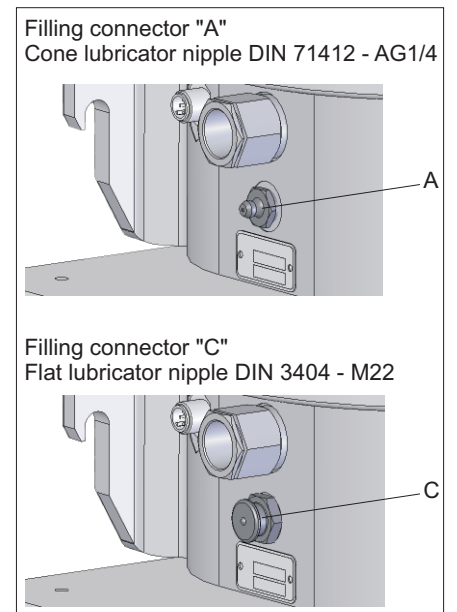
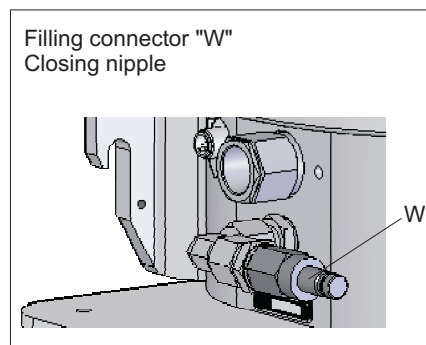
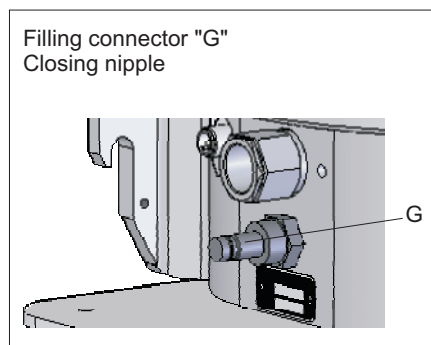

- Subject to modifications -

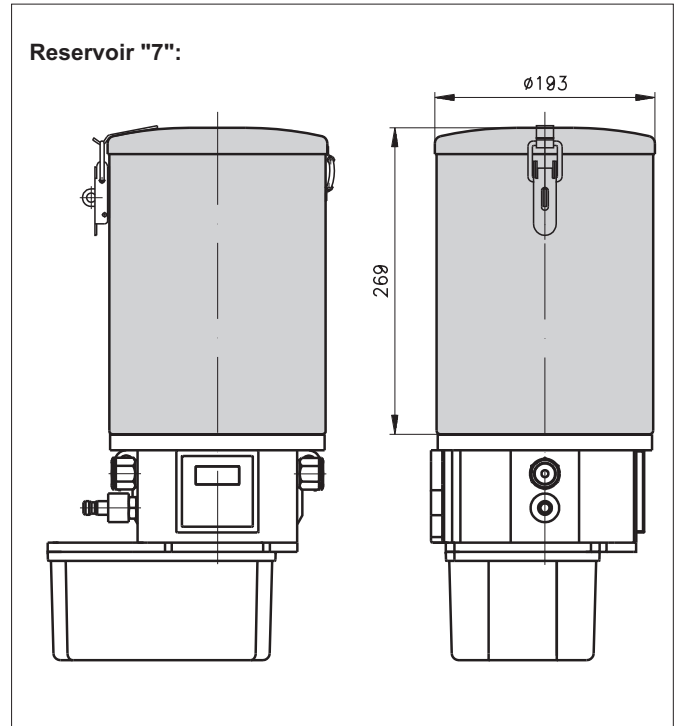
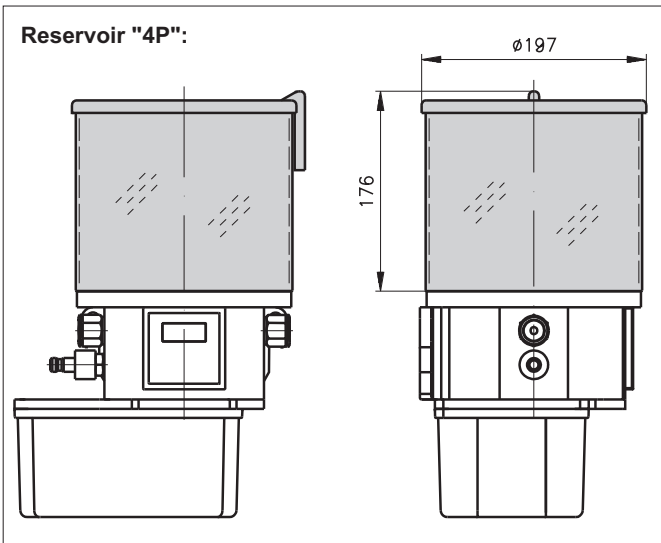
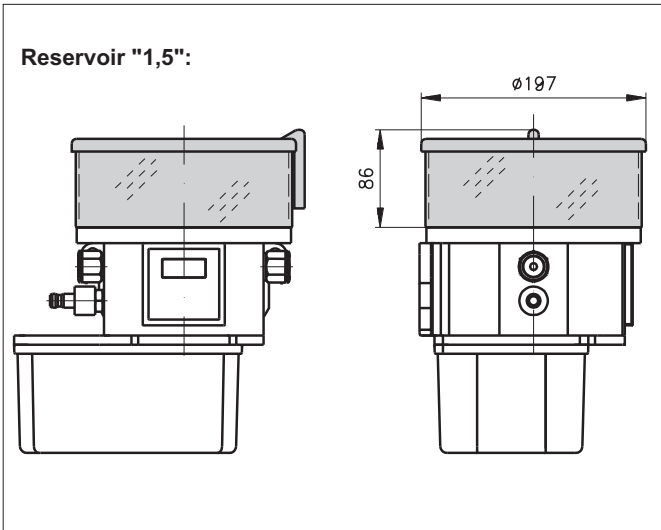
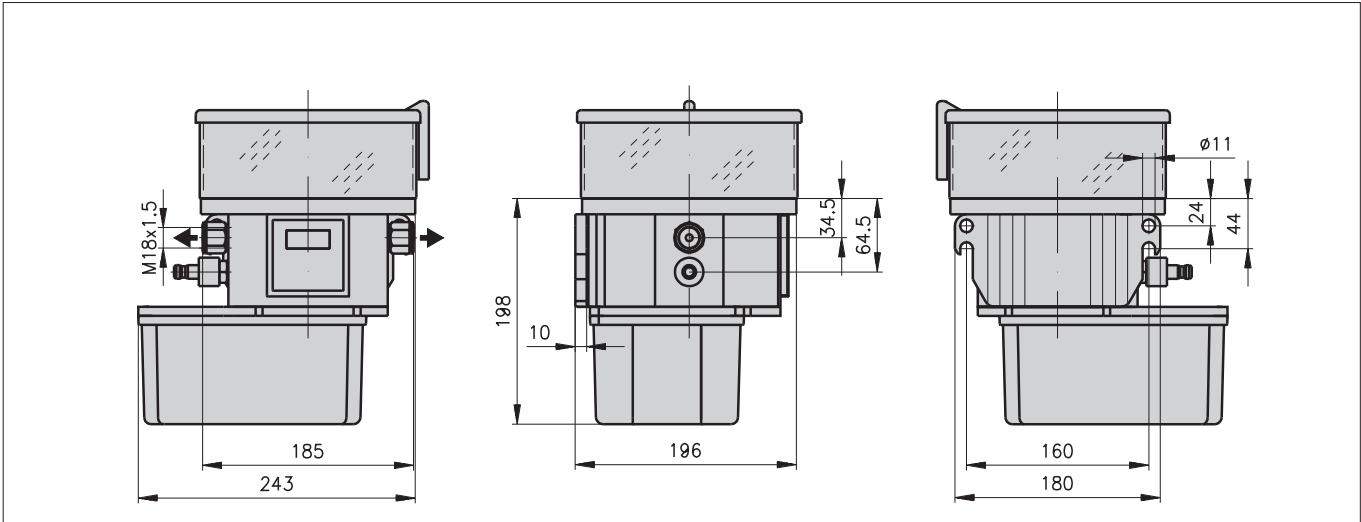

- Subject to modifications -

	Capacity [l]	Material	
		Reservoir	Lid
Reservoir "1,5"	1,5	Polyamide translucent	Polypropylene
Reservoir "4P"	4	Polyamide translucent	Polypropylene
Reservoir "7"	7	Steel, galvanized	Steel galvanized

other reservoir versions available on request



Flanged progressive distributor:

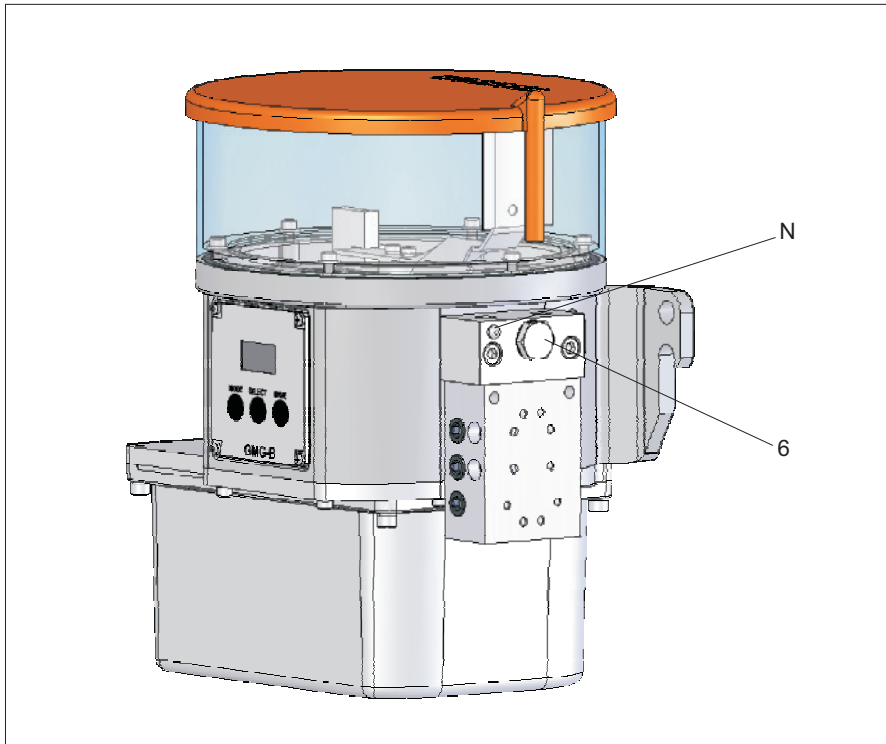

At the right-side pump element, progressive distributors of the VPB type can be flanged on directly. As much as 20 lubrication points with different distribution volumes are possible. A selection of progressive distributors can be chosen by means of the GMG-B purchase-designation.

Functionality:

The lubricant supplied by the pump element is delivered to the outlet progressively (i.e. progressing in the distributor).

Function control:

By monitoring the movement of one distributor piston, the lubricant allocation to all outlets is monitored. Evaluation through the pump control unit requires selection of a progressive distributor fitted with the function control RK.

Technical data progressive distributor:

Metering volume per cycle and outlet:	0,20 cm ³
Lubrication point connectors:	4, 6 or 8 other versions available on request (up to 20 lubrication points)
Operating pressure at max.:	150 bar
Delivery medium	
Oil-viscosity:	as of approx. 140 cP (equals ISO VG46 at 20°C)
Grease up to:	NLGI class 2
In case of oil, metering accuracy depends on viscosity, flow resistance at the outlets, and delivery speed.	
Material	
Outer body:	Aluminium
Inner parts:	Steel
Additional information	
on VPB-G:	Leaflet-no.: 0177
on VPB-B:	Leaflet-no.: 0378

Distributor variants (VPB-G):

4 outlets		
without function checking device	"P4"	
with function checking device RK	"P5"	
6 outlets		
without function checking device	"P0"	
with function checking device RK	"P1"	
8 outlets		
without function checking device	"P2"	
with function checking device RK	"P3"	

Note on operation:

Upon start-up, both pump element and progressive distributor need to be vented. The lubricant must come out free of bubbles from all outlets.
At first, the connecting case should be vented at venting screw **6** or at the built-in pressure control valve. Then, the progressive distributor should be vented.

Note:

The 0,16 cm³ delivery volume pump element is marked by means of a grey plastic pimple **N**.

Auxiliaries:

Pressure control valve at the progressive distributor:

For delimitation of the maximum operating pressure, pressure control valves **7** instead of the venting screw **6** can be screwed in.

Opening pressure:	Purchase-no.:
70 bar	110.566-65
150 bar	110.564-65
Customised setting:	
50 - 150 bar	110.568-65

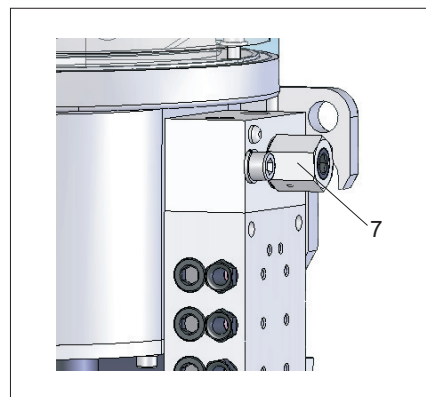

Function control RK:

Switching voltage:	10 ... 36 VUC
Switching current at max.:	25 mA
Switching power at max.:	0,9 VA
Ambient temperature:	0 ... 60 °C
Material (casing):	PA or 1.4305

- Subject to modifications -

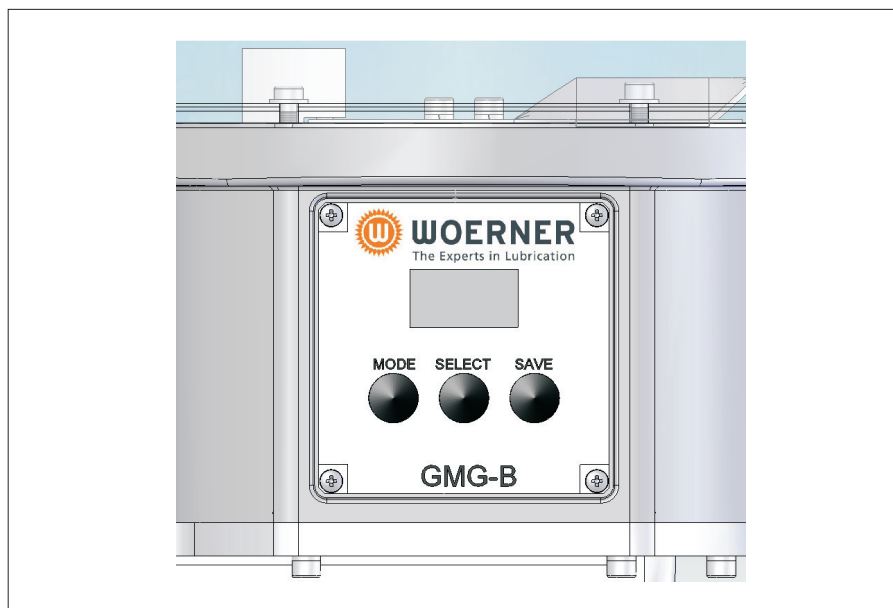
Control unit:

The control unit serves to monitor and trigger the pump aggregate. It is capable of switching the pump on and off depending on time and load. Besides, the control unit can be used to monitor the filling level and functionality of the progressive distributor. In case of failure, a corresponding message can be made accessible to a higher ranking system. The control unit must be started via an external "release".

Control variant "B":

Control without distributor monitoring.

Control variant "B1":

Control with distributor monitoring for progressive distributor flanged on.

Control variant "B2":

Control with distributor monitoring for externally mounted progressive distributor (with functional checking device "RS"). For connecting cable see "Auxiliaries" below.

Control unit operation:

- Menu call-up:**
By long pressing the "MODE" key, the menu structure is called up.
- Navigation within the menus:**
By keeping the "Mode" key depressed another time, the menu items P1 ... P11 can be selected successively.
- Changing of values:**
The „SELECT" key can be used to change setting values and functions. In case of time data, short pressing of the "SELECT" key results in a shifting by +1, whereas any longer pressing will result in a shifting by +20. When the "SAVE" key is depressed for a while, the set values will be saved. Pressing the "MODE" key enables the next menu item to be accessed without any saving action.
- Special Functions:**
When the "SELECT" key is depressed in the operating mode "ON" for a while, pumping action will be carried out for 60 seconds.

Electric connection 8:

Connection type: Connector socket 5-pin (M12)

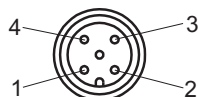
Version with control unit:

- +24 VDC
- +24 VDC (external release)
- 0 V
- Alarm output

Version without control unit:

- +24 VDC (delivery function)¹⁾
- +24 VDC (stirring function)¹⁾
- 0 V
- Level monitoring

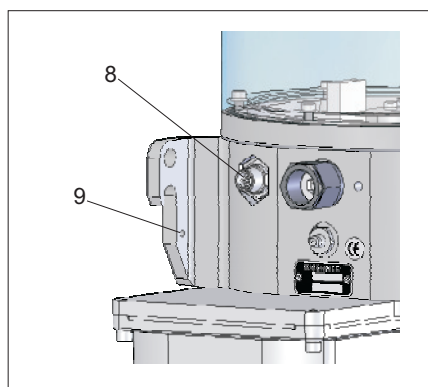
¹⁾ **Explanation:**

Delivery function: 24 V to Pin 1
 Stirring function: 24 V to Pin 1 and 2

Equipotential bonding 9:

Threaded hole: M4

Fault Description:

E1 = Motor overloaded
 E2 = Progressive distributor faulty
 E3 = Level fault

Fault messages can be deleted by keeping the "SAVE" key depressed for a while.

Technical data:

Power consumption: 1,7 W
 Supply voltage: 24 VDC ± 5 %
 Voltage at inputs: 24 VDC
 Response time of inputs: 200 ms
 Input resistance: 4 kΩ
 Temperature range: -20 °C ... +60 °C
 Outlet alarm: 200 mA / 24 VDC / 60W
 Data buffer: 10 years

Auxiliaries:
Cable jack for electric connection:

Operating voltage: 10 ... 30 VDC
 Cable cross section: 4x0,34 mm²
 System of protection: IP67

Purchase-number

Cable length 10 m: **913.404-65**
 Cable length 15 m: **913.405-07**

Connecting cable for externally mounted progressive distributor:
Purchase-number

Cable length 2 m: **913.405-06**
 (other cable lengths available on request)

Connection type: Plug on socket 4-pin M12 - M12

- Subject to modifications -



- Subject to modifications -

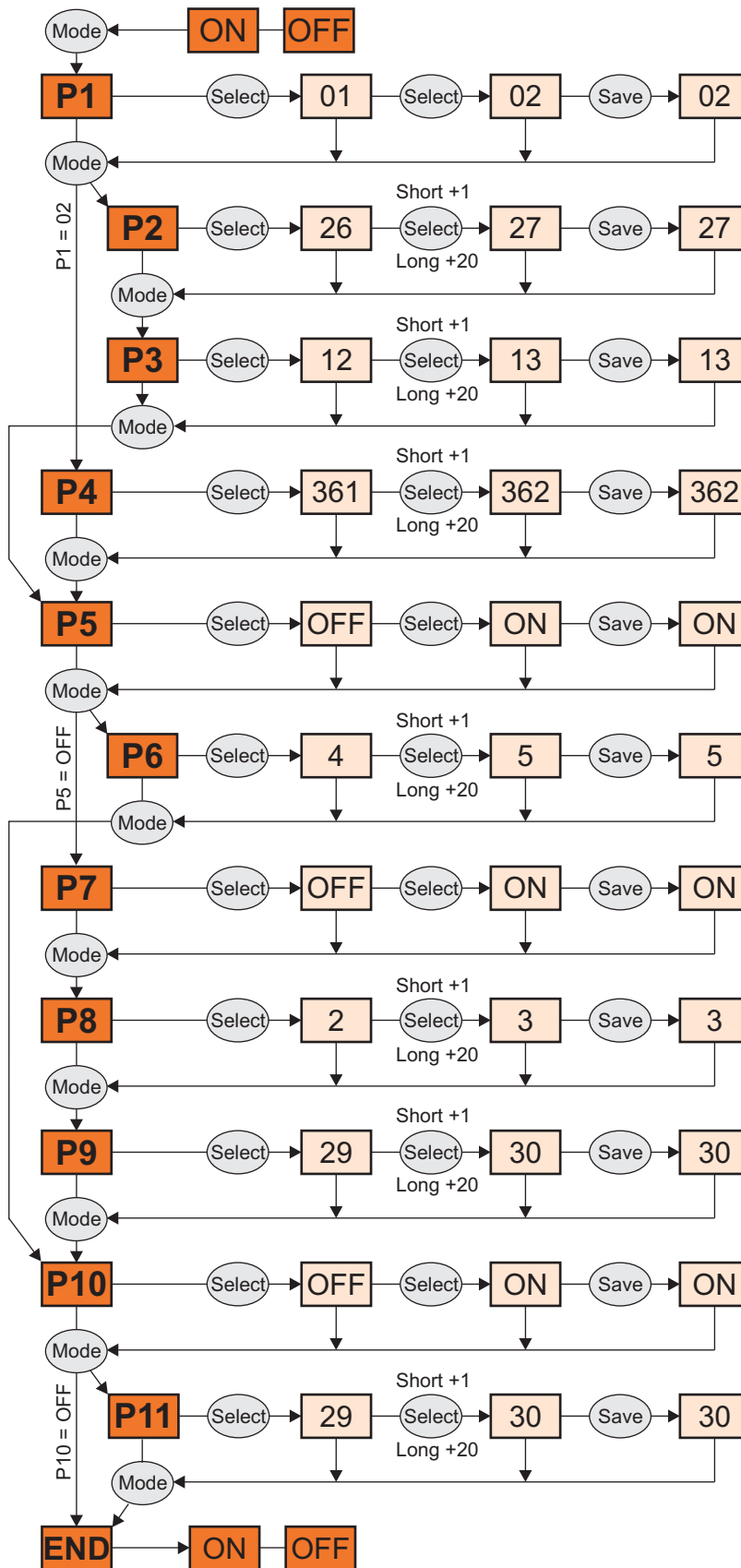

Time Mode / Pulse Mode: P1

Selection between time mode 01 and pulse mode 02
Default = 01

Cycle Time¹⁾ h: P2

Cycle time setting in hours (0-255) Only in P1 = time mode
Default = 0

Cycle Time¹⁾ min: P3

Cycle time setting in minutes (1-59) Only in P1 = time mode
Default = 2

Pulses: P4

Pulse setting (1-999) Only in P1 = pulse mode
Default = 5

Distributor Pulse: P5

Ends pumping action after elapse of pre-set pulse number ON = on, OFF = off
Default = OFF

Distributor Pulse Number: P6

Distributor pulse setting (1-100) Only in P5 = distributor pulse ON mode
Default = -

Distributor Monitoring: P7

Fault message release after 4 min. without distributor signal. ON = on, OFF = off
Default = OFF

Delivery Time h: P8

Delivery time setting in hours (0-100) Only in P5 = distributor impulse OFF mode
Default = 0

Delivery Time min: P9

Delivery time setting in minutes (1-59) Only in P5 = distributor pulse OFF
Default = 1

Stirring: P10

Selection between "Stirring on" = ON and "Stirring off" = OFF (stirring time 1 min.)
Default = OFF

Off-duty Time for Stirring: P11

Off-duty Time setting in hours (1-100) Only in P10 = Stirring ON
Default = 1

¹⁾ Cycle time = delivery time + off-duty time



Purchase-designation:
Pump aggregat

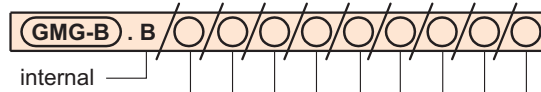

Reservoir	Level checking	Follow-up piston	Filling connector	Pump element		Electric control	Drive ²⁾	flanged progressive distributor without / with function control
				left	right			
1,5l Polyamide (1,5)	For grease: Intermittent min. level monitoring (C)		Cone lubrication nipple DIN 71412 (A) Flat lubrication nipple DIN 3404-M22 (C) Closing nipple (G)	0,08cm ³ (08)	0,08cm ³ (08)	Control unit without distributor monitoring (B) Control unit with distributor monitoring (B1) Control unit with external distributor monitoring (B2) without control unit (0)	24VDC Delivery and stirring always concurrently (3) 24VDC Stirring, without and with delivery (3A)	VPB-G, 4 outlets (P4) / (P5) VPB-G, 6 outlets (P0) / (P1) VPB-G, 8 outlets (P2) / (P3) VPB-G / VPB-B acc. to purchase designation ¹⁾ (P*) without (0)
4l Polyamide (4P)	For oil²⁾: Min. level (F)	without (0)	Closing nipple (G)	0,16cm ³ (16)	0,16cm ³ (16)			
7l Steel (7)	without (0)		Closing nipple angled (W) without (0)	without (0)	without (0)			

- Subject to modifications -

¹⁾ Progressive distributors P... with function control can only be selected together with control unit B1.

²⁾ With level monitoring "F", grease cannot be stirred.

If the function control of a progressive distributor is not to be connected to the pump control unit, then GMG-B with variant "PX" has to be selected with the progressive distributor getting a separate purchase designation.

Should the function control of a mounted progressive distributor with separate purchase-designation be connected to the GMG-B pump control unit, the variant "P*" for the pump and the function control "R0" for the progressive distributor have to be selected.

When using variant "P*", progressive distributors of the types VPB-B or VPB-G with up to 20 lubrication points can be mounted.

For the versions, please see
Data sheet VPB-B: No. 0378
Data sheet VPB-G: No. 0177

Purchase-example:

Pump aggregate GMG-B with reservoir 1,5l; with level monitoring "C"; with filling connector "G"; pump element with 0,08cm³ delivery stroke on the left side and 0,16cm³ delivery stroke on the right side; with electric control unit incl. distributor monitoring "B1" and 24VDC drive type "3A"; and progressive distributor with 6 outlets and monitoring

Purchase-designation:

GMG-B.B / 1,5 / C / 0 / G / 08 / 16 / B1 / 3A / P1

Auxiliary: (state purchase-no., please)

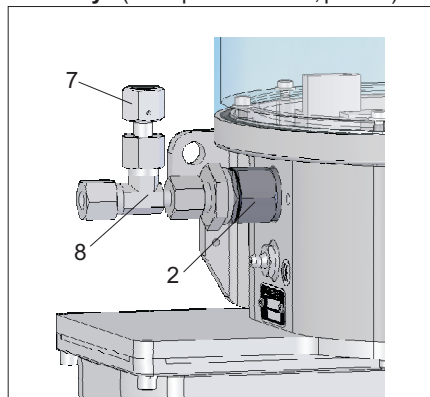

Pressure control valve at the pump element:

For operating pressure delimitation, pressure control valves 7 can be connected to the pumpelement 2

Pressure control valve 7 with opening pressure:	Purchase-no.:	Screwing kit 8 for pipe:	Purchase-no.:
70 bar	752.502-65	Ø 6	752.502-68
150 bar	752.502-62	Ø 8	752.502-63
250 bar	752.502-90	Ø 10	752.502-64
Customised setting:			
50 - 160 bar	752.502-66		
160 - 250 bar	752.502-67		