



## WLM Model AURA Manual

### 1. Thanks

We thank you for having chosen the WLM reference monitor **AURA** and the confidence you have thus proven in our product.

Due to the new functioning of the WLM speakers we are asking you to read this manual carefully before connecting or operating your speakers. Your benefits: an optimized installation will lead to an improved sound reproduction.

### 2. Supply

The supply of the AURA loudspeakers comprises:

- 2 AURA - speakers
- 1 aiming gauge (for the positioning of the left/right speakers)
- This manual
- Warranty Registration Form

**Note:** the aiming device is separate pack in the main box.

The **packaging** of the cabinets provides a perfect protection to our product during transportation. We recommend to keep it for future shipping needs.

### 3. Description

The model AURA is equipped with a built-in filter and can thus be operated in the "passive" mode (directly connected to your amplifier).

**Passive / Active Switching Device** (optional)

With this option the AURA can at any time and easily be up-graded to a fully "active" speaker system. Via the switching device the signal path will by-pass the built-in filter located in the rear terminal.

**Note:** The toggle-switches of the Passive / Active Switching Device are secured to avoid the risk of damage through an inadvertent operation (e.g. when the external filter has not been installed). Pull the switch out of its notched-in rest position before you can actually operate it.

**In the fully active mode the external WLM filter "SYSTEM CONTROL" is to be employed.**

**Due to the risk of damage, never operate the AURA in the active mode without an external filter system!**

Standard

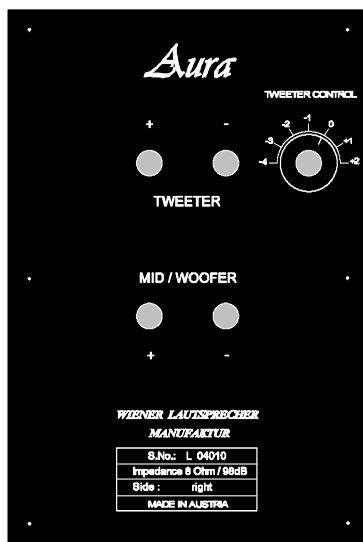

Passive- / Active-Switching Device  
(optional)

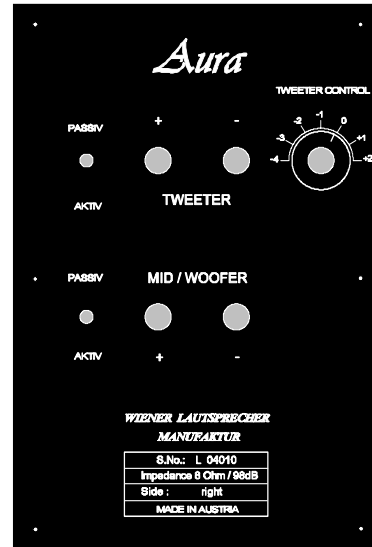

The solid WBT connector terminals for bi-wiring accept all known loudspeaker cable ends: bare cables, banana or forked cable shoes.

It is up to your personal preference whether you want to operate your speakers with or without its front covers. They have little or no effect on the quality of the sound reproduction.

**Please keep in mind that the speakers have a bass reflex opening in the cabinet. It is vital that the sound waves coming from this aperture should "radiate" freely to all sides.**

#### 4. Positioning of the Speakers

The unique WLM PAC technology will be put to maximum effect only when the following rules and guidelines are observed.

The pair of speakers consist of a **LEFT** and **RIGHT** box (seen from the listener's position); they differ one from another and should not be switched by mistake. At the rear terminal the boxes are marked "L left" and "R right".

The distance between the boxes themselves should be 1.5 times the distance of the boxes to the listener's place.

**Example:** supposing that the listener is 3.0 m away from the boxes, then the distance between the boxes should be 4.5 m.

For the purpose of a perfect sound stage, the distance behind the boxes to the rear wall should be at least 1.0 m, preferably more. The distance to the side wall should be considerably less than that (>0.25 m).

Thanks to the WLM PAC-Technology (more about this below) the clearly noticeable sound stage will built up between the speakers, quite similar to a large blister.

For the final and precise positioning of boxes the aiming device supplied should be employed without fail. Place this device on top of the cabinets (right on the tweeter assembly) and change its inner gauge block left/right as marked. The marked front edge of the aiming device (gauge block with aiming wedge and main unit) should face the listener as shown in the drawing below. The boxes are in the right position when the respective gauge lines are pointing directly at the listener.

##### 4.1 PAC – Speaker aiming device

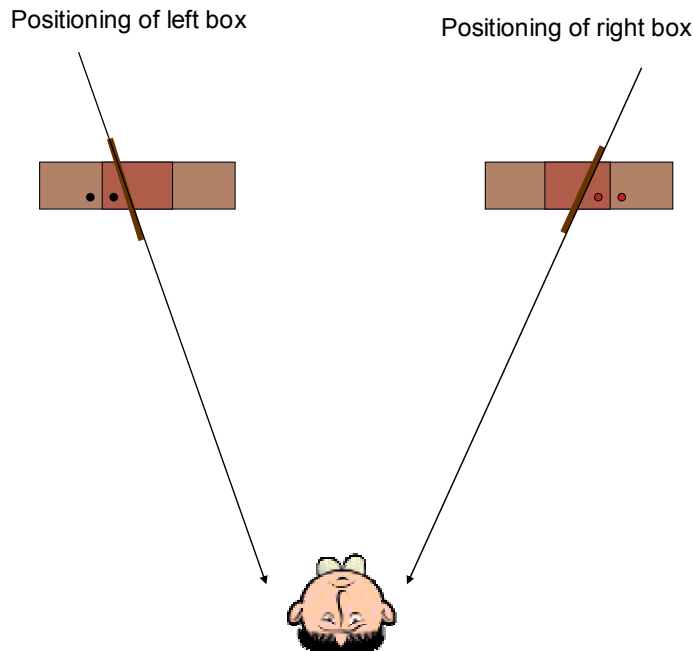

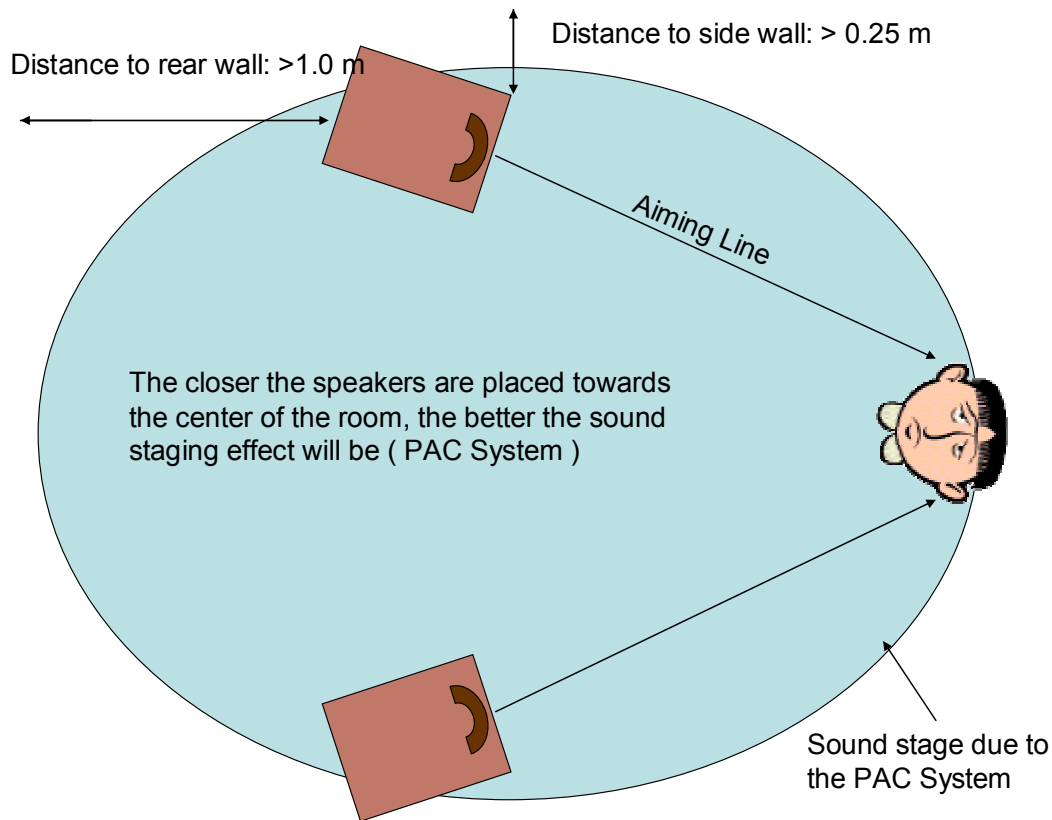

## **Adjustments of the speakers to the listening environment**

### **5. Connection possibilities**

#### **5.1 Passive Operation Mode**

The AURA speakers are made as standard for the so-called "passive" operation mode, and thus to be connected directly to the speaker outputs of the integrated amplifier or of the power amplifier.

By means of the "**TWEETER CONTROL**" (built in the terminal of each speaker as standard), the upper frequencies of the AURA can be adjusted to the prevailing room acoustics and according to the individual listening preference.

#### **5.2 Partly active operation mode with WLM "PASSIVE CONTROL" (optional)**

The very useful WLM device **PASSIVE CONTROL** will enable you to operate the passive AURA speakers in a partly active mode.

The middle and lower frequencies of the signal can be adjusted to the surrounding environment by an **active** rectification during the reproduction of these frequencies. A noticeable extension of the lower portion of a signal is the appreciable result.

In addition to the adjustment according to room acoustics, it will produce also greater warmth and fullness of sound, besides a clearly improved and well controlled bass foundation.

**Note:** When using the PASSIVE CONTROL module with the AURA speakers, choose the position "PASSIV" of the Passiv-/Aktiv- switch at the speaker terminal.

## Different connections of PASSIVE CONTROL

### Integrated Amp:

#### Connection to TAPE IN and TAPE MONITOR OUT of the amp

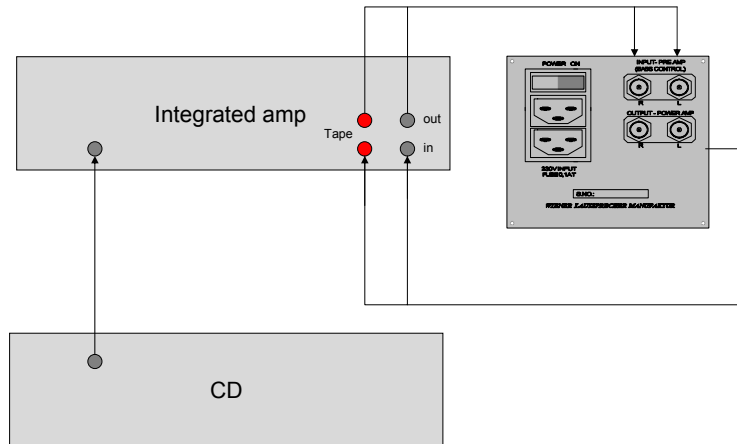

#### Connection between SOURCE and AMP:

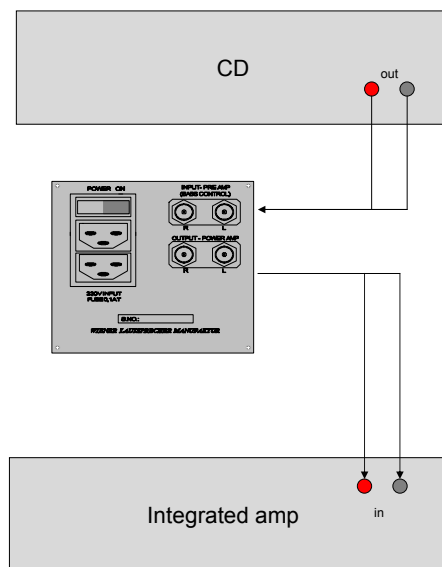

## Pre-Amp / Power Amp combination:

### Connection between PRE-AMP and POWER AMP

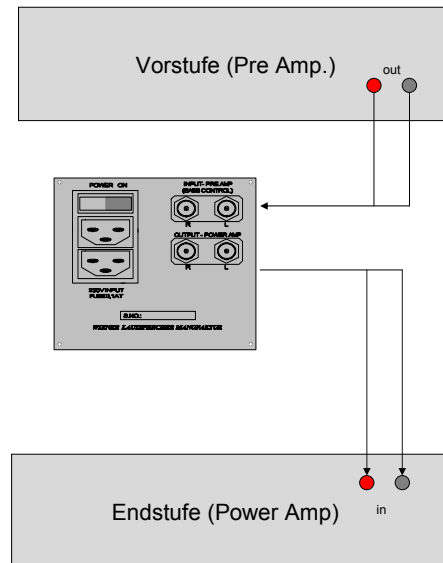

### **Adjustment of the active low frequency rectification:**

PASSIVE CONTROL offers an adjustment band width from 0 dB to +12 dB. The adjustments are continuous (without steps) governed by the prevailing room acoustics, the type and character of a given recording and the individual listening preference.

In the position **0 dB**, PASSIVE CONTROL is not actively working! In this position the actual lower frequencies of the passive signal will be reproduced unmodified by the AURA speakers.

PASSIVE CONTROL offers a choice between **"Full Range"** and **"Sat + Woofer"** mode (switch).

### **"Full Range" operation:**

When the AURA speakers are not used in combination with a subwoofer then the "Full Range" operation is to be chosen. In this mode the AURA is reproducing the entire signal band width, also the lower frequencies.

### **"Sat + Woofer" operation:**

This is the right choice when the AURA is operated together with a subwoofer (e.g. WLM DUO). In this mode the signal frequencies are split; the frequencies below 80 Hz are directed to the subwoofer. In conjunction with the WLM device BASS CONTROL and an active WLM DUO subwoofer a perfect frequency split can thus be obtained.

# Connection of PASSIVE CONTROL + BASS CONTROL

## Integrated Amp:

### Connection between SOURCE and AMP:

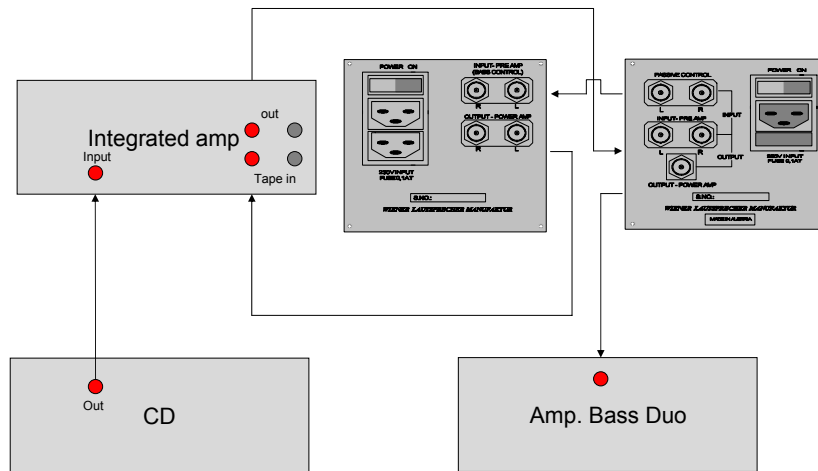

## Pre-Amp / Power Amp combination:

### Connection between PRE-AMP and POWER AMP

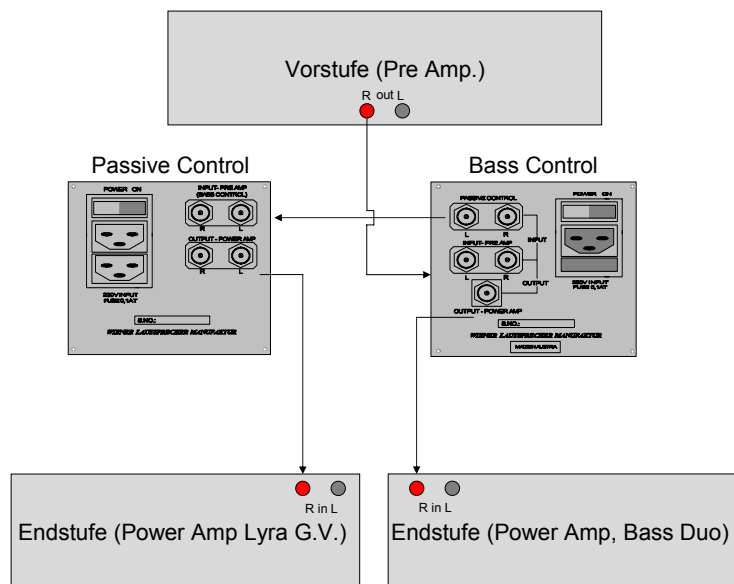

## **6. Technical Explanations**

### **Speaker Efficiency**

The efficiency of a speaker system, measured in sound pressure (dB at 1W, at a distance of 1 m), specifies its effectiveness of reproducing a given signal. The higher the efficiency, the lower the demand regarding the performance of an amplifier and the efforts required to reach higher volume levels.

WLM speakers excel in this respect, since they offer an exceptional and unusual efficiency of 98 dB (1W, 1m).

### **6.2 Impulse Behavior**

The faster and the more precise a speaker responds to the changes of a signal impulse (by swinging the membrane forward and backward), the better the sound impression will be. The smallest delays between the reception of the impulse and its transformation (initiation of the membrane movement and its stop) will have a distinct impact on the quality of the sound reproduced and perceived.

The specially hard support of the paper membranes on one side and the extremely strong, high performance magnet coils on the other side are warrants for an extraordinary impulse behavior of all WLM speaker systems.

### **6.5 PAC ("*Phase Acoustic Corrected*")**

PAC stands for a special and unique advantage of the WLM speakers; i.e. the capability of reproducing an almost perfect sound stage in 3-dimensional extension with 2 speakers.

To understand this concept we have to explain that lower frequencies alone do not lend themselves and are therefore not vital for the stage building process during the sound reproduction. Only with higher frequencies stage building (and perception) is possible. Therefore, to reproduce a given signal in a space-like manner it is important that it contains medium and high frequencies together with the lower frequency waves.

The prevailing sounds in our surrounding world, usually deriving from single sources, consist of a mix of different frequencies and are discerned and located readily in a given space context. On the other hand, our ears have to accomplish the difficult task to amalgamate the sounds reproduced "artificially" by 2 separate loudspeakers via special drivers for high and medium/low frequencies to a full space-like entity.

Speakers having conventional tweeter concepts in a variety of techniques are fighting with the difficulty to fuse the higher and lower frequencies deriving from the 2 stereo speakers for space-like perception. The high frequency waves conventionally emitted in front direction do not merge with the medium and low frequency waves coming from the same speaker and also not with the high frequencies portions coming from the tweeter of the other (stereo) speaker. The listener's ear can not be betrayed, he will hear the speakers rather than the music in its appropriate spacious extension. In addition, the higher frequencies are traveling so much faster to our ears than the medium or lower signal portions. This will result in disturbing time lags over the entire frequency range, overemphasizing the distinct 2-channel reflection of sound, also destroying any chance of a natural, space-like perception of the music reproduced.



The special execution and positioning of the tweeter system of the WLM speakers is enabling first the homogenous merging of the high frequencies emerging from the 2 juxtaposed speakers and then also the merging with the medium and low frequencies of a given signal coming from different drivers. The WLM listener is able to hear a distinctly structured sound stage image. No longer is he limited and fixed to a narrowing 2-channel reproduction of his speakers. In the listener's acoustic perception the WLM-PAC speakers will actually disappear in the background. He will experience the rare and rewarding feeling of being put right in the middle of the recording atmosphere.

The world unique PAC technology is granting for the first time an almost perfect space-like imaging of recorded music from 2 loudspeakers only.

## 7. Specification: AURA

Drivers	PAC – Tweeter-System 8" paper cone chassis
Impedance	8 Ohm
Frequency Response	35 Hz* to 20kHz (*with Passive Control)
Sensitivity	98 dB - 1m/1W
Recommended Amplifier Power	3,5 to 200 Watt
Wiring Methods	Bi-Wiring
Dimensions	18,90" (480 mm) high 9,00" (230 mm) wide 11,81" (300 mm) deep
Weight	24,10 LB (11 Kg) each

## 8. Warranty

### Limited Warranty

During the warranty period the *Wiener Lautsprecher Manufaktur* will guarantee that their products are free of flaws and well functioning

The warranty periods for the various products are: Loudspeaker AURA - 5 years, PASSIVE CONTROL and BASS CONTROL - 2 years (counted from the date of purchase at an authorized WLM-Dealer).

Condition for the warranty service is that the products are operated in accordance with this manual.

During the warranty period WLM will replace or repair the defect parts free of charge to the customer.

Condition is however:

- The warranty registration card is received by WLM within 30 days after the date of purchase.
- The cabinets are not showing any traces of physical damage and inside there are no signs of overheating due to wrong installation/operation resulting in an overloading of certain parts.
- The PCBs and components thereof are not showing any signs of undue handling, regardless whether the intention was to repair or to modify the unit under claim
- There is no indication what-so-ever that the WLM products have been operated differently as specified by the manual..

In addition, the customer will lose his right for a warranty claim when the serial-Nr. of the unit in question has been modified, removed or manipulated in any way. WLM will not be held responsible for damages resulting from repairs executed by un-authorized personnel.

### Collateral Damage

During the duration of this limited warranty period (and there-after) WLM will not be responsible for collateral damage, directly or indirectly linked to the operation of the WLM product.

### Warranty claim

The customer may on the basis of this limited warranty claim the repair or replacement of the defective part by the manufacturer or the authorized dealer with no charge to him. For the claim please contact either WLM directly or the WLM distributor in your country. After receipt of the claim confirmation please send the unit under claim to the shown address. The defect will be examined and, when justified, will be repaired at no cost to the customer. The customer will have to bear the cost of shipment. Without a corresponding warranty claim (received within 30 days after the date of purchase at the address below) no warranty claim will be accepted or processed.

WLM Loudspeakers  
Treietstrasse 56  
A-6832 Sulz  
AUSTRIA

Phone: +43 (0)5522 44641 (Customer Service)  
Web: [www.wlm-loudspeakers.com](http://www.wlm-loudspeakers.com)

# WLM Warranty Registration

Please ask your dealer to fill in this form at the time of the purchase.

This registration will entitle you to call on WLM for technical support and it is a prerequisite for an eventual warranty claim against WLM.

Please send your registration to:

**WLM Loudspeakers**  
**Treietstrasse 56**  
**A-6832 Sulz**  
**Austria**

Customer Service:  
Phone : +43 (0)5522 44641  
Fax : +43 (0)5522 44641-74  
Web : [www.wlm-loudspeakers.com](http://www.wlm-loudspeakers.com)

Unit/Model: **AURA**.....Serial-Nr.:.....

Unit/Model: **PASSIVE CONTROL**...Serial-Nr.:.....

Unit/Model: **BASS CONTROL**.....Serial-Nr.:.....

Date of Purchase:.....Dealer Name:.....

Dealer Address:.....

First/last name of customer: .....

Address Street: .....

Postal Code/Town: .....

Customer Contact Phone: .....

Fax: .....

E-Mail: .....

Your comments are always appreciated: