

OFFICEMATE 2D



User Manual

This manual provides detailed information on how to operate and maintain your Officemate 2D.

Please read this manual before operating the machine in order to prevent any damage caused by improper handling

Thank you for purchasing a Welltec System's product.

This manual is prepared to provide you with guidelines on how to properly operate and maintain the Officemate 2D.

Copyright

Any of the contents should not be copied, re-printed or translated by other languages without Welltec System's approval.

Officemate 2D is the registered trademark of Welltec System.

OFFICEMATE 2D Spec.

The Officemate 2D offers a real office-friendly Pressure Sealer with perfect sealing quality and extremely low noise level. It is capable of processing 2,000 forms per hour.

OFFIMEMATE 2D Spec.

- Form Size : A4 / Letter / Legal size
- Speed : 2,000 forms / hour
- Input Tray : up to 150* forms
- Form weight : 60-120gsm
- Folding Setting : Z, C, V & Double, 14" uneven Z
- Noise Level : less than 45db
- weight : 22kg (Without packaging)
- Dimension : 320 X 390 X 280mm(WxLxH)
- *based on 80gsm paper weight.

Unpacking Your Machine

Content

Please check if all of the following parts are included in the box

- Power cable, 1ST Fold Cassette, 2nd Fold Cassette, Stacker, User manual

(1st Fold Cassette is already inserted onto the machines from the factory.)



[Box open]



[2nd cassette, Stacker & Power cable]



[Remove the safety tape]



[Power & on/off switch]

* Power connection : Please refer to the label for electric information which is located at the back side of the machine. If it is not working properly, please contact your local dealer for service

Identifying parts



① Paper Guide

Load the paper on the guide. (Prepare paper by making edges neat before loading).

② Press Adjustment

Adjust the pressure for the paper (Adjust sliders to suit paper weight).

③ Power socket

Main power socket located on the back of the machine.

④ 2nd Fold Cassette

Insert the 2nd Cassette on the back of the machine.

⑤ Roller Cover

Open fold roller cover when jam occurs. (Please turn the Knob in clockwise rotation for unlock).

⑥ 1st Fold Cassette

Insert the 1st Cassette for first folding forms.

⑦ Start/Stop

⑧ Output : Finished forms exit the front of the machine.

⑨ Stacker

Folding Cassette Guide

A Fold cassette setting guide with ruler is attached on the front of the hopper. Please select the folding type you require and adjust the 1st and 2nd cassette location based on this information.

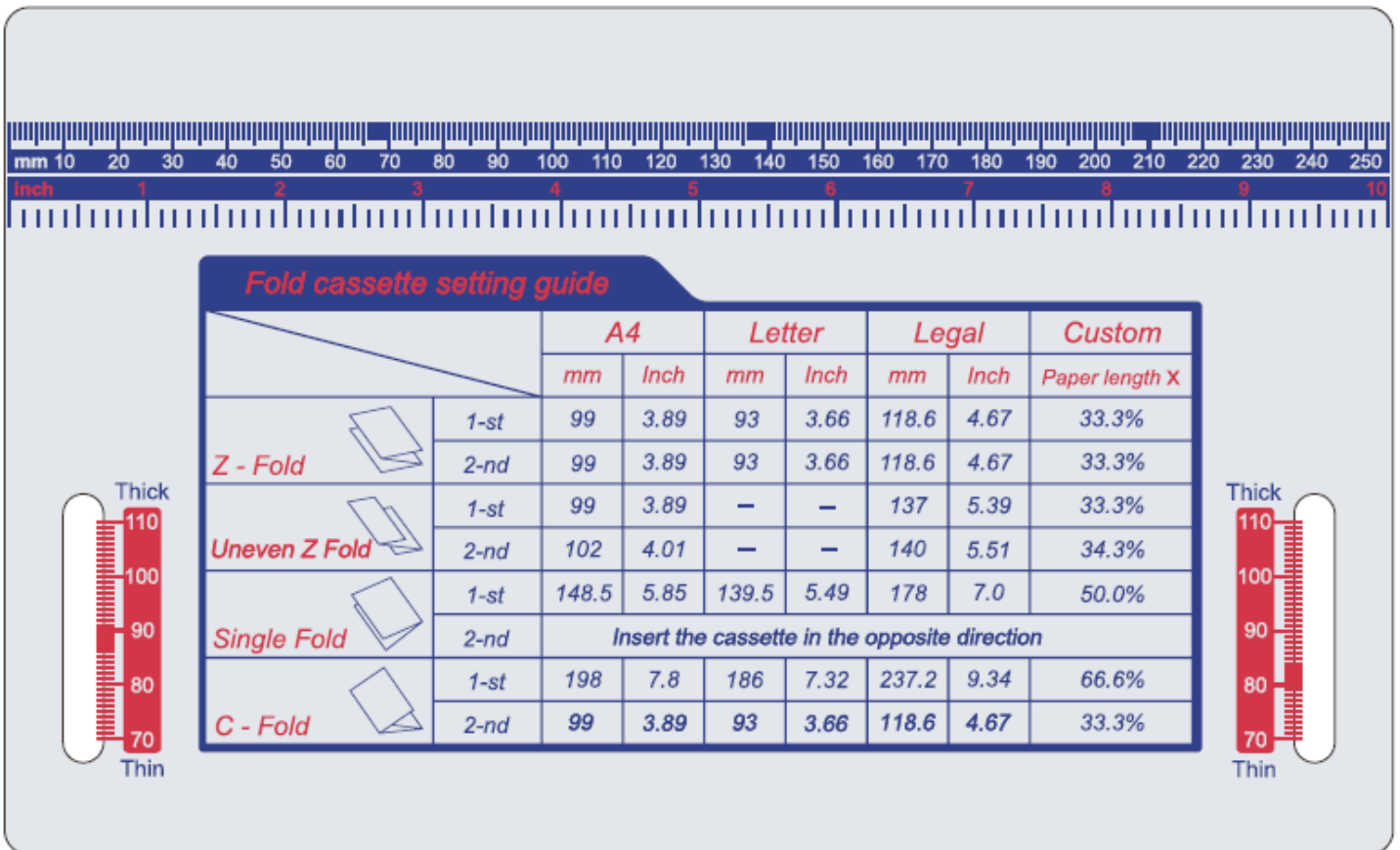

If you want to process V-Fold documents (single fold) please remove the 2nd fold cassette, rotate and replace

How to install the Fold Cassettes

Please follow these instructions to adjust the fold 1st and 2nd Fold Cassettes.

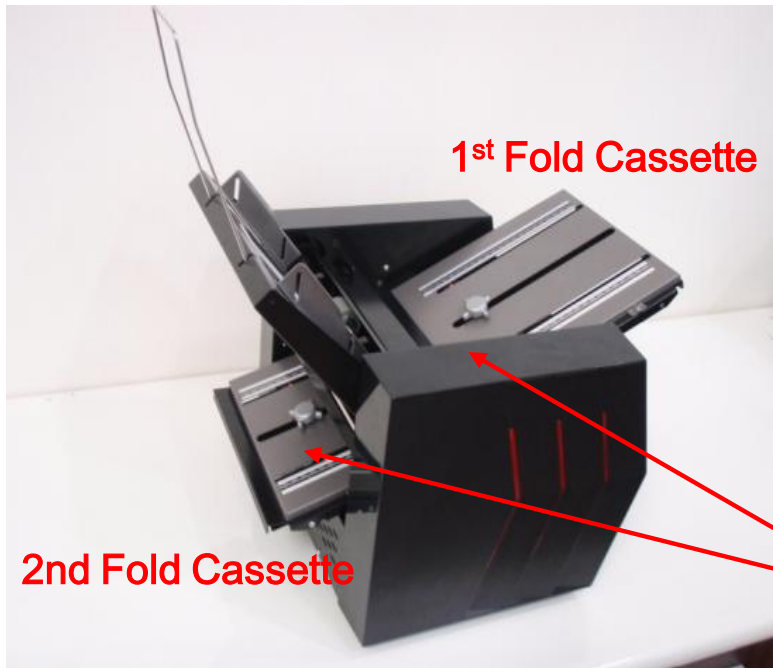

1. the 1st cassette is inserted on the front of the machine.
2. Insert the 2nd cassette on the back of the machine.

Knob for fold cassette adjustment

1st Cassette

2nd cassette

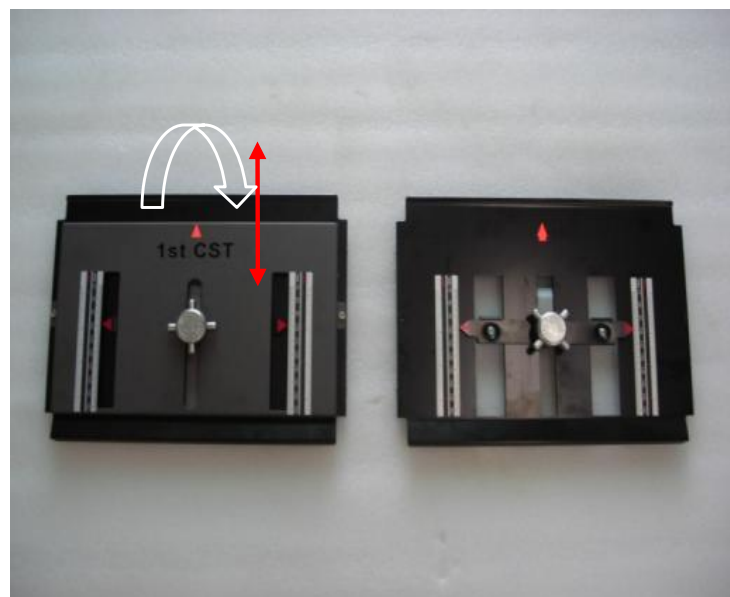

Adjusting the Fold Cassette

Turn the Knob to adjust the fold cassette to the desired paper size (Refer to fold assist label on top of the in-feed tray.)

Different Folding cassettes for different paper sizes

The OFFICEMATE 2D has a 3 different kind of 1st folding plate based on the folding type required.

		Standard (148mm plate)	240mm plate	270mm plate
Option		Basic	Option	Option
Fold Type	Z	Letter, A4, LEGAL	Letter, A4, LEGAL	Letter, A4, LEGAL
	V	Letter, A4	Letter, A4, LEGAL	Letter, A4, LEGAL
	C	NA	Letter, A4, LEGAL	Letter, A4, LEGAL
	Uneven C	NA	NA	Letter, A4, LEGAL
Price		Included	Optional Extra	Optional Extra
Remarks				

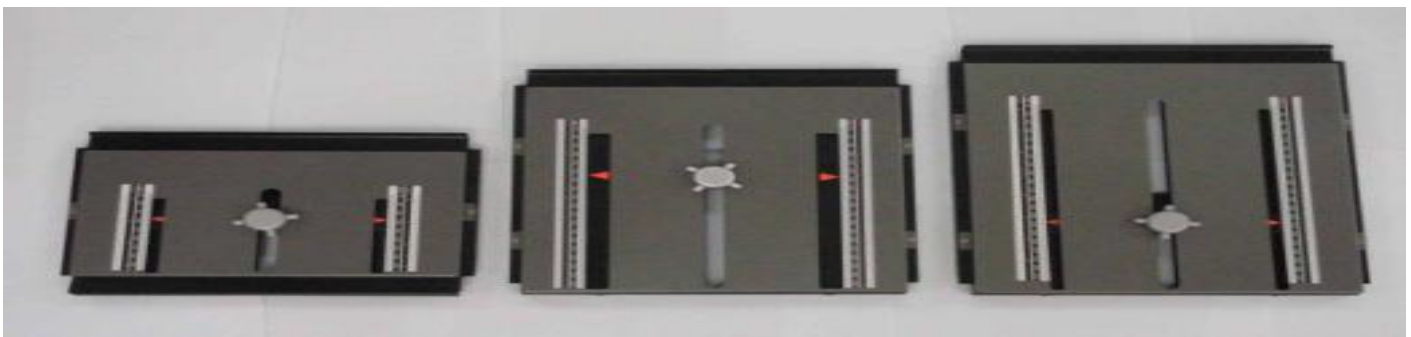

Standard 148mm

240mm Fold Cassette

270mm Fold Cassette

Features

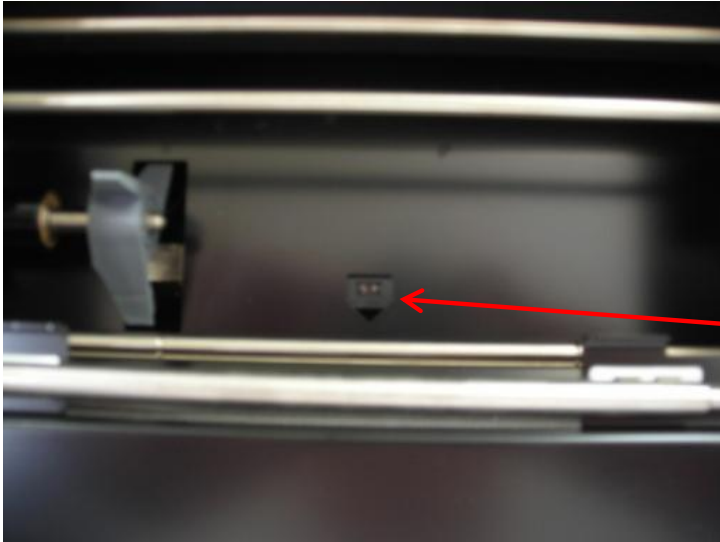

- **Paper Jam Detection** : This sensor will detect a paper jam and stop the machine.
- **Please note** you will have to remove the jammed form before restarting the machine.

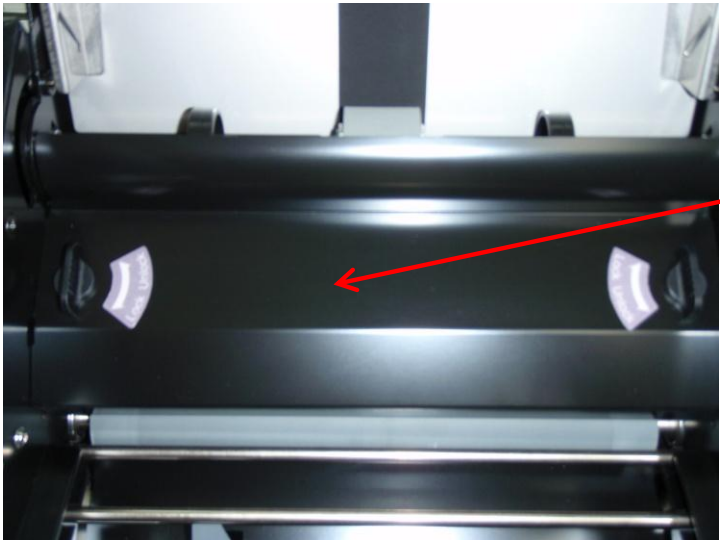

- * **Limit sensor for fold roller cover.** The machine will not run with this cover missing or if this cover is removed while the machine is running.

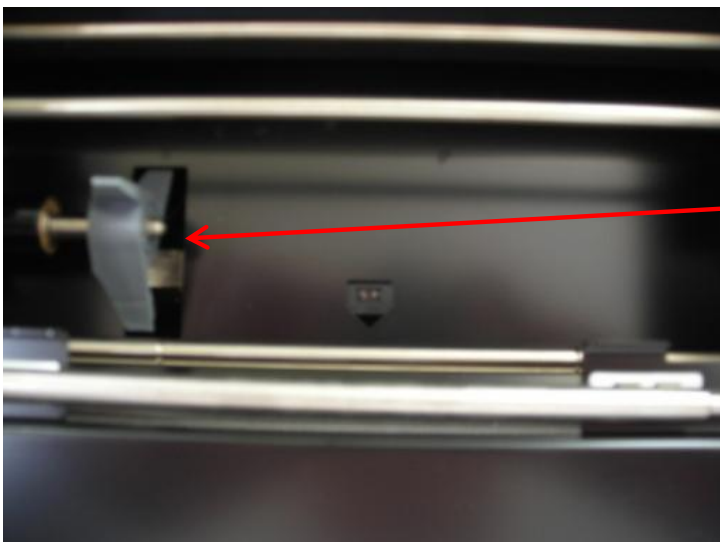

Paper Alignment Paddle. Please do not remove this item. Your machine will not function properly without it

Fan the pressure seal forms to separate and to eliminate any static that may have been caused by the laser printer.

Place the forms into the paper tray in the correct orientation as indicated by the chart below. The paper tray will hold up to 100 sheets of pressure seal paper. To correctly place your forms in the paper tray, square-off & neaten the stack and, push the paper tray back so the forms will rest on the solid plate and behind the feed roller. The paper tray is sprung-loaded to apply the correct amount of pressure for proper feeding.

It is always a good idea to fold one form to verify that the fold-plate settings are correct and have not been changed. Adjust if necessary and then proceed to load your forms in the paper tray, press start button to fold and seal your forms.

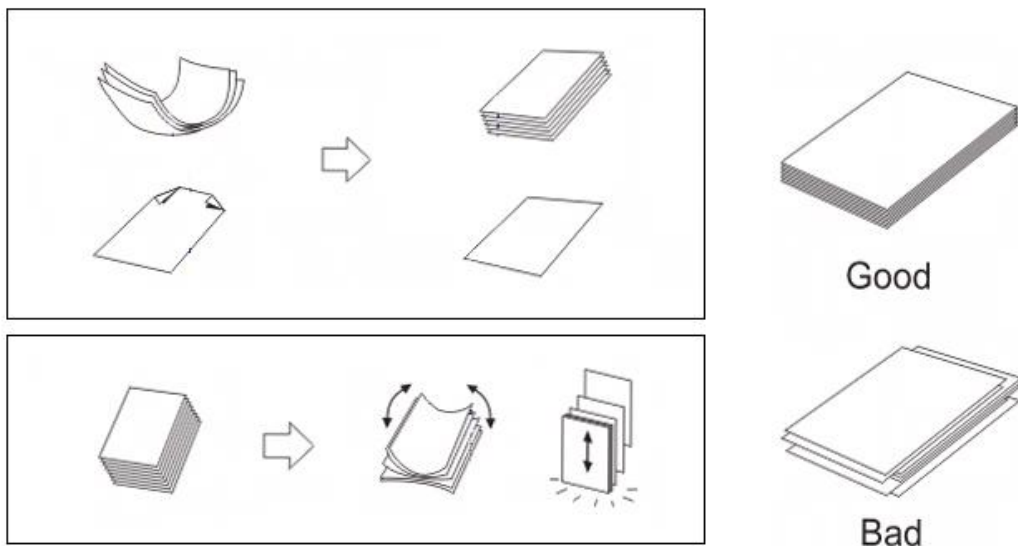

Loading the Paper Hopper

It is important that you load the paper hopper correctly to minimize the risk of paper jams occurring.

Fan the pressure seal forms to separate and to eliminate any static that may have been caused by the laser printer.

Adjusting the hopper paper guides to the correct location



Please note.

The hopper will take up to 150 printed forms. However please do not overload the hopper. This will result in miss-feeding

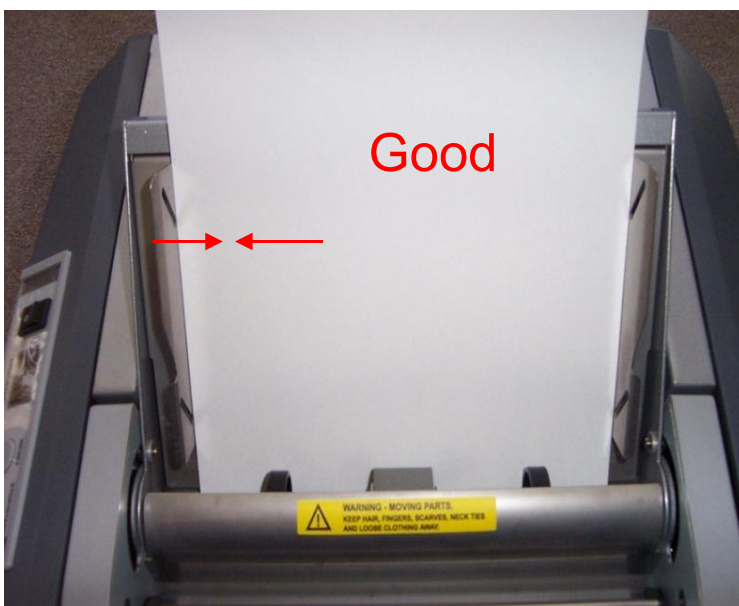

Paper Guide Tension

Insure that the side guides are right up against the edge of the form but not compressing the form

Jam removal

You can easily remove a paper jam as illustrated below.

If a paper jam has occurred, the machines will automatically stop after a few seconds. After removing the paper jam, simply press the “red : start” button for the machine to restart.



[Pull the 1st cassette back]

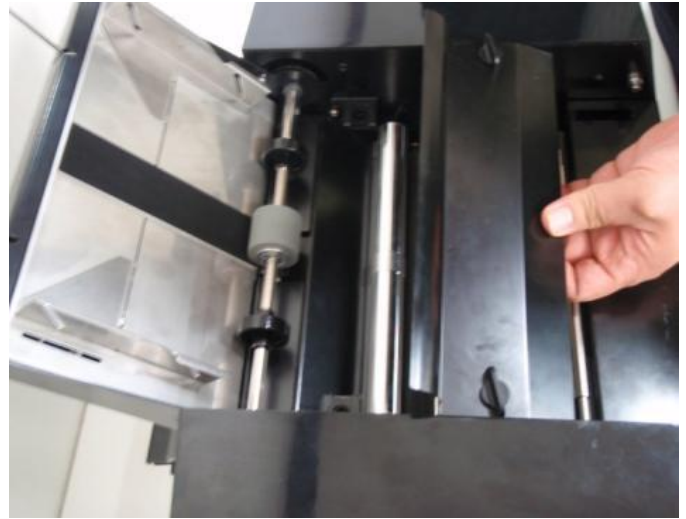

[Remove the fold roller cover]

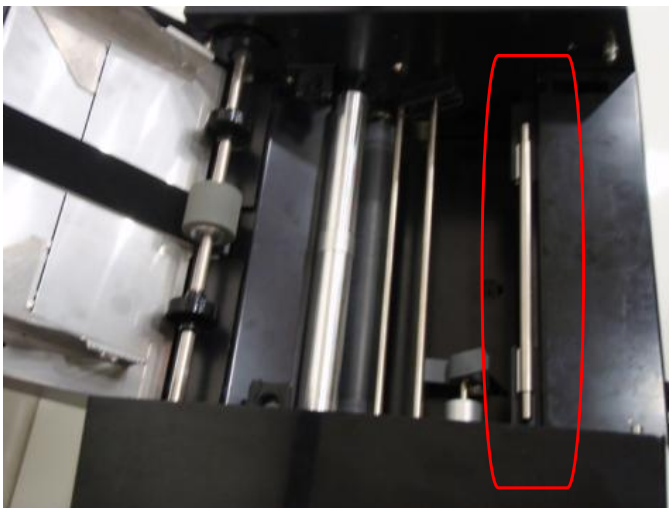

[[Locate the jam removal tool]



[Insert the jam removal onto the hole of roller
and pull it down]

- **Caution : Please Remember to remove replace the jam removal tool back into its holder once the paper jam has been cleared.**

Since pressure seal forms leave paper dust as well as ink and toner residues, it is very important to occasionally clean the surface of the each roller to ensure optimum performance.

1. Paper Dust

Use small air cleaner or dust remover

2. Pick-up and Fold rollers

Clean the feed roller as well as the aluminum and rubber rollers inside the folding unit with roller cleaning fluid. Do not use oil as this will damage the surface of the rubber.

3. Sealing Rollers

With general use, toner will build up on the pressure rollers. Check the rollers for build up of toner and clean on a regular basis using a suitable roller cleaning fluid. The degree of build up will vary according to the type of printer, toner & fuser used.

Caution : Do not use any other substance to clean the surface of the fold rollers as it may damage the rubber.

Please contact your service tech for further details on suitable cleaning solutions to be used.



Welltec system

www.welltec.co.kr

Headquarter & Factory
1075-93, Sungsunk-dong, Ilsandong-gu, Gyoyang-si,
Gyeonggi-Do, Korea
Tel : 82-31-977-4711 Fax ; 82-31-977-471
sales@welltec.co.kr