

INSTALLATION MANUAL

R-410A OUTDOOR SPLIT-SYSTEM HEAT PUMP

MODELS: 18 SEER - YZE03811 SERIES
3 TON



TABLE OF CONTENTS

GENERAL	1	EVACUATION	13
SAFETY	1	SYSTEM CHARGE	13
UNIT INSTALLATION	2	SYSTEM OPERATION	14
INSTALLATIONS REQUIRING TXV	5	INSTRUCTING THE OWNER	14
ELECTRICAL CONNECTIONS	5	WIRING DIAGRAM	15

LIST OF FIGURES

Typical Installation	2	Thermostat Wiring – Two-Stage Heat Pump - Variable Speed Air Handler	9
Tubing Hanger	3	Thermostat Wiring – Two-Stage Heat Pump - Variable Speed Air Handler	10
Underground Installation	4	Thermostat Wiring – Two-Stage Heat Pump - Variable Speed Modulating Furnace	11
Heat Protection	4	Thermostat Wiring – Two-Stage Heat Pump - Variable Speed Modulating Furnace	12
Typical Field Wiring	5	Heat Pump Flow Diagram	13
CFM Selection Board	6	Wiring Diagram	15
Thermostat Wiring – Two-Stage Heat Pumps - Two-Stage Variable Speed Furnaces	7		
Thermostat Wiring – Two-Stage Heat Pump - Two-Stage Variable Speed Furnaces	8		

LIST OF TABLES

Defrost Initiate Curves	14	R-410A Saturation Properties	14
-------------------------------	----	------------------------------------	----

SECTION I: GENERAL

The outdoor units are designed to be connected to a matching indoor coil with sweat connect lines. Sweat connect units are factory charged with refrigerant for the smallest rated indoor coil plus 15 feet of field supplied lines.

Matching indoor coils are available with a thermal expansion valve or an orifice liquid feed sized for the most common usage. The orifice size and/or refrigerant charge may need to be changed for some indoor-outdoor unit combinations, elevation differences or total line lengths. Refer to Application Data covering "General Piping Recommendations and Refrigerant Line Length" (Part Number 036-61920-001).

SECTION II: SAFETY



This is a safety alert symbol. When you see this symbol on labels or in manuals, be alert to the potential for personal injury.

Understand and pay particular attention to the signal words **DANGER**, **WARNING**, or **CAUTION**.

DANGER indicates an **imminently** hazardous situation, which, if not avoided, **will result in death or serious injury**.

WARNING indicates a **potentially** hazardous situation, which, if not avoided, **could result in death or serious injury**.

CAUTION indicates a potentially hazardous situation, which, if not avoided **may result in minor or moderate injury**. It is also used to alert against unsafe practices and hazards involving only property damage

WARNING

Improper installation may create a condition where the operation of the product could cause personal injury or property damage. Improper installation, adjustment, alteration, service or maintenance can cause injury or property damage. Refer to this manual for assistance or for additional information, consult a qualified contractor, installer or service agency.

CAUTION

This product must be installed in strict compliance with the enclosed installation instructions and any applicable local, state, and national codes including, but not limited to building, electrical, and mechanical codes.

CAUTION

*R-410A systems operate at higher pressures than R-22 systems. Do not use R-22 service equipment or components on R-410A equipment. Service equipment **Must Be Rated** for R-410A.*

INSPECTION

As soon as a unit is received, it should be inspected for possible damage during transit. If damage is evident, the extent of the damage should be noted on the carrier's delivery receipt. A separate request for inspection by the carrier's agent should be made in writing. See Local Distributor for more information.

Requirements For Installing/Serviceing R-410A Equipment

- Gauge sets, hoses, refrigerant containers, and recovery system must be designed to handle POE oils, and the higher pressures of R-410A.
- Manifold sets should be 800 PSIG high side and 250 PSIG low side with 550 PSIG low side restart.
- All hoses must have a 700 PSIG service pressure rating.
- Leak detectors should be designed to detect HFC refrigerant.
- Recovery equipment (including refrigerant recovery containers) must be specifically designed to handle R-410A.
- Do not use an R-22 TXV.
- A liquid-line filter drier is required on every unit.

LIMITATIONS

The unit should be installed in accordance with all National, State and Local Safety Codes and the limitations listed below:

1. Limitations for the indoor unit, coil and appropriate accessories must also be observed.
2. The outdoor unit must not be installed with any duct work in the air stream. The outdoor fan is the propeller type and is not designed to operate against any additional external static pressure.
3. The maximum and minimum conditions for operation must be observed to assure a system that will give maximum performance with minimum service.

AIR TEMPERATURE DB AT OUTDOOR COIL, °F				AIR TEMPERATURE AT INDOOR COIL, °F			
Min.		Max.		Min.		Max.	
Cool	Heat	Cool	Heat	°WB Cool	°DB Heat	°WB Cool	°DB Heat
50	-10	115	75	57	50 ¹	72	80

1. Operation below this temperature is permissible for a short period of time, during morning warm-up.
4. This unit is not designed to operate with a low ambient kit. Do not modify the control system to operate with any kind of low ambient kit.
5. The maximum allowable line length for this product is 75 feet.

SECTION III: UNIT INSTALLATION

LOCATION

Before starting the installation, select and check the suitability of the location for both the indoor and outdoor unit. Observe all limitations and clearance requirements.

The outdoor unit must have sufficient clearance for air entrance to the condenser coil, for air discharge and for service access. See Figure 1.

NOTE: For multiple unit installations, units must be spaced a minimum of 18 inches apart. (Coil face to coil face.)

If the unit is to be installed on a hot sun exposed roof or a black-topped ground area, the unit should be raised sufficiently above the roof or ground to avoid taking the accumulated layer of hot air into the outdoor unit.

Provide an adequate structural support.

ADD-ON REPLACEMENT/RETROFIT

When this unit is being used as a replacement for an R-22 unit, it is required that the outdoor unit, indoor coil, and metering device all be replaced. The following steps should be performed in order to insure proper system operation and performance. Line-set change out is also recommended.

1. Change-out of the indoor coil to an approved R-410A coil/condensing unit combination with the appropriate metering device.
2. Change-out of the line-set when replacing an R-22 unit with an R410-A unit is highly recommended to reduce cross-contamination of oils and refrigerants.
3. If change-out of the line set is not practical, then the following precautions should be taken.
 - Inspect the line set for kinks, sharp bends, or other restrictions, and for corrosion.
 - Determine if there are any low spots which might be serving as oil traps.
 - Flush the line set with a commercially available flush kit to remove as much of the existing oil and contaminants as possible.
 - Install a suction line filter-drier to trap any remaining contaminants, and remove after 50 hours of operation.
4. If the outdoor unit is being replaced due to a compressor burnout, then installation of a 100% activated alumina suction-line filter drier in the suction-line is required, in addition to the factory installed liquid-line drier. Operate the system for 10 hours. Monitor the suction drier pressure drop. If the pressure drop exceeds 3 psig, replace both the suction-line and liquid-line driers. After a total of 10 hours run time where the suction-line pressure drop has not exceeded 3 psig, replace the liquid line drier, and remove the suction-line drier. Never leave a suction-line drier in the system longer than 50 hours of run time.

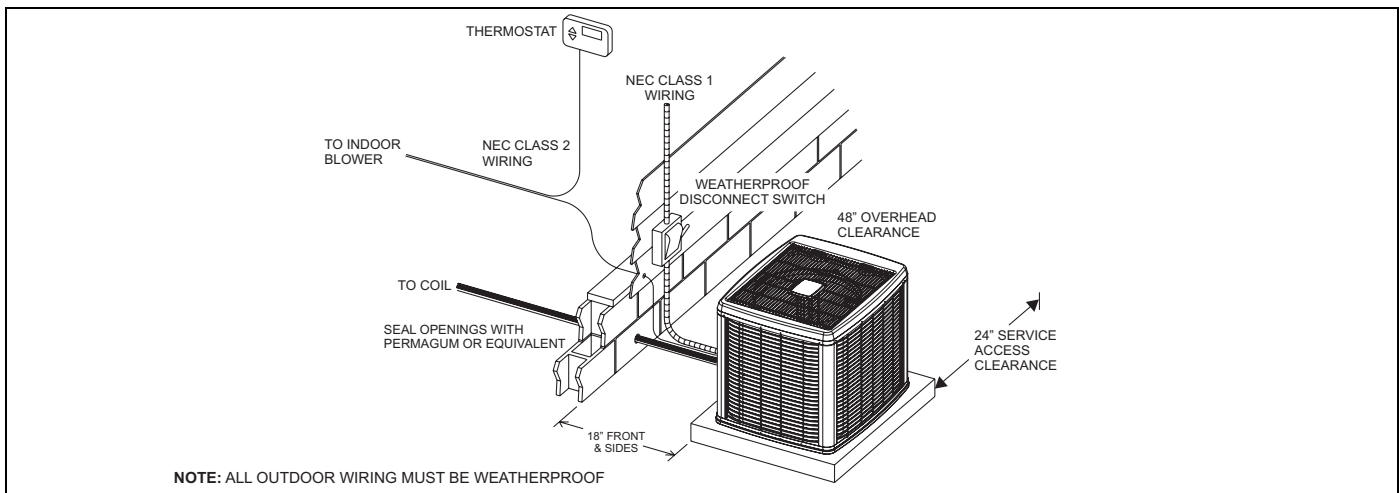

FIGURE 1: Typical Installation

GROUND INSTALLATION

The unit may be installed at ground level on a solid base that will not shift or settle, causing strain on the refrigerant lines and possible leaks. Maintain the clearances shown in Figure 1 and install the unit in a level position.

Normal operating sound levels may be objectionable if the unit is placed directly under windows of certain rooms (bedrooms, study, etc.).

Condensate will drain from beneath the coil of the outdoor unit during the defrost cycle. Normally this condensate may be allowed to drain directly on the ground.

WARNING

The outdoor unit should not be installed in an area where mud or ice could cause personal injury. Remember that condensate will drip from the unit coil during heat and defrost cycles and that this condensate will freeze when the temperature of the outdoor air is below 32°F.

Elevate the unit sufficiently to prevent any blockage of the air entrances by snow in areas where there will be snow accumulation. Check the local weather bureau for the expected snow accumulation in your area. Isolate the unit from rain gutters to avoid any possible wash out of the foundation.

ROOF INSTALLATION

When installing units on a roof, the structure must be capable of supporting the total weight of the unit, including a pad, lintels, rails, etc., which should be used to minimize the transmission of sound or vibration into the conditioned space.

UNIT PLACEMENT

1. Provide a base in the pre-determined location.
2. Remove the shipping carton and inspect for possible damage.
3. Compressor tie-down bolts should remain tightened.
4. Position the unit on the base provided.

NOTE: Heat pumps will defrost periodically resulting in water drainage. The unit should not be located where water drainage may freeze and create a hazardous condition - such as sidewalks and steps.

LIQUID LINE FILTER-DRIER

The heat pumps have a solid core bi-flow filter/dryer located on the liquid line.

NOTE: Replacements for the liquid line drier must be exactly the same as marked on the original factory drier. See Source 1 for O.E.M. replacement driers.

CAUTION

Failure to do so or using a substitute drier or a granular type may result in damage to the equipment.

R-410A / R-22 Filter-Drier Source 1 Part No.	Apply with Models
	YZE
026 - 25512 - 000	All Sizes

PIPING CONNECTIONS

CAUTION

This system uses R-410A refrigerant which operates at higher pressures than R-22. No other refrigerant may be used in this system. Gauge sets, hoses, refrigerant containers, and recovery system must be designed to handle R-410A. If you are unsure, consult the equipment manufacturer.

WARNING

Never install a suction-line filter drier in the liquid line of an R-410A system. Failure to follow this warning can cause a fire, injury or death.

The outdoor unit must be connected to the indoor coil using field supplied refrigerant grade copper tubing that is internally clean and dry. Units should be installed only with the tubing sizes for approved system combinations as specified in Tabular Data Sheet. The charge given is applicable for total tubing lengths up to 15 feet. See Application Data Part Number 036-61920-001 for installing tubing of longer lengths and elevation differences.

NOTE: Using a larger than specified line size could result in oil return problems. Using too small a line will result in loss of capacity and other problems caused by insufficient refrigerant flow. Slope horizontal vapor lines at least 1" every 20 feet toward the outdoor unit to facilitate proper oil return.

PRECAUTIONS DURING LINE INSTALLATION

1. Install the lines with as few bends as possible. Care must be taken not to damage the couplings or kink the tubing. Use clean hard drawn copper tubing where no appreciable amount of bending around obstruction is necessary. If soft copper must be used, care must be taken to avoid sharp bends which may cause a restriction.
 2. The lines should be installed so that they will not obstruct service access to the coil, air handling system or filter.
 3. Care must also be taken to isolate the refrigerant lines to minimize noise transmission from the equipment to the structure.
 4. The vapor line must be insulated with a minimum of 1/2" foam rubber insulation (Armaflex or equivalent). Liquid lines that will be exposed to direct sunlight and/or high temperatures must also be insulated.
- Tape and suspend the refrigerant lines as shown. DO NOT allow tube metal-to-metal contact. See Figure 2.
5. Use PVC piping as a conduit for all underground installations as shown in Figure 3. Buried lines should be kept as short as possible to minimize the build up of liquid refrigerant in the vapor line during long periods of shutdown
 6. Pack fiberglass insulation and a sealing material such as perma-gum around refrigerant lines where they penetrate a wall to reduce vibration and to retain some flexibility.
 7. See Form 690.01-AD1V for additional piping information.

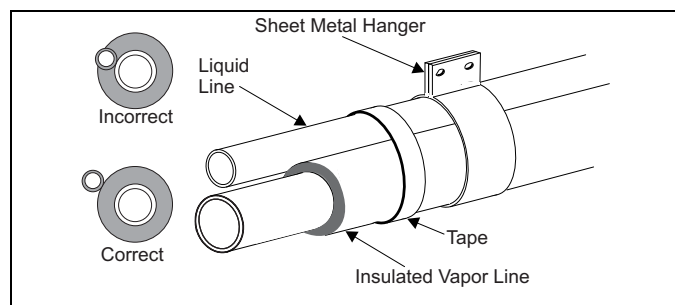

FIGURE 2: Tubing Hanger

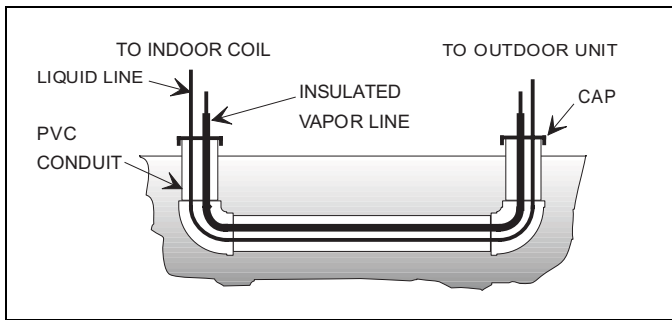

FIGURE 3: Underground Installation

PRECAUTIONS DURING BRAZING OF LINES

All outdoor unit and evaporator coil connections are copper-to-copper and should be brazed with a phosphorous-copper alloy material such as Silfos-5 or equivalent. DO NOT use soft solder. The outdoor units have reusable service valves on both the liquid and vapor connections. The total system refrigerant charge is retained within the outdoor unit during shipping and installation. The reusable service valves are provided to evacuate and charge per this instruction.

Serious service problems can be avoided by taking adequate precautions to assure an internally clean and dry system.

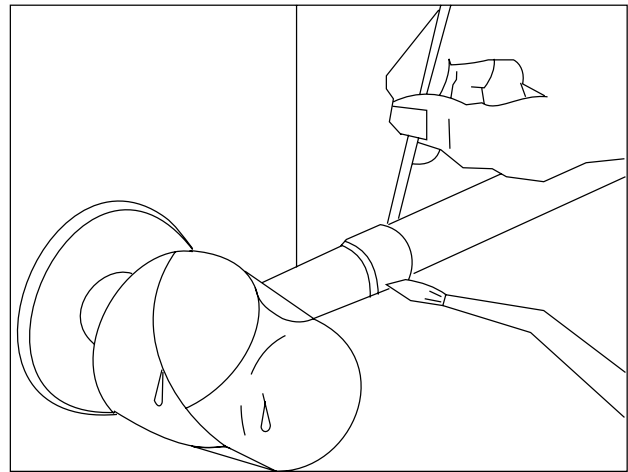

FIGURE 4: Heat Protection

CAUTION

Dry nitrogen should always be supplied through the tubing while it is being brazed, because the temperature required is high enough to cause oxidation of the copper unless an inert atmosphere is provided. The flow of dry nitrogen should continue until the joint has cooled. Always use a pressure regulator and safety valve to insure that only low pressure dry nitrogen is introduced into the tubing. Only a small flow is necessary to displace air and prevent oxidation.

PRECAUTIONS DURING BRAZING SERVICE VALVE

Wrap a wet rag around the service valve as shown in Figure 4 to prevent heat damage. Also, protect all painted surfaces, insulation, and plastic base during brazing. After brazing cool joint with wet rag.

WARNING

This is not a backseating valve. The service access port has a valve core. Opening or closing valve does not close service access port.

If the valve stem is backed out past the chamfered retaining wall, the O-ring can be damaged causing leakage or system pressure could force the valve stem out of the valve body possibly causing personal injury.

Valve can be opened by removing the plunger cap and fully inserting a hex wrench into the stem and backing out counter-clockwise until valve stem just touches the chamfered retaining wall.

Connect the refrigerant lines using the following procedure:

1. Remove the cap and Schrader core from both the liquid and vapor service valve service ports at the outdoor unit. Connect low pressure nitrogen to the liquid line service port.
2. Brazed the liquid line to the liquid valve at the outdoor unit. Be sure to wrap the valve body with a wet rag. Allow the nitrogen to continue flowing. Refer to the Tabular Data Sheet for proper liquid line sizing.
3. Carefully remove the rubber plugs from the evaporator liquid and vapor connections at the indoor coil.

CAUTION

The evaporator is pressurized.

4. Brazed the liquid line to the evaporator liquid connection. Nitrogen should be flowing through the evaporator coil.
5. Slide the grommet away from the vapor connection at the indoor coil. Brazed the vapor line to the evaporator vapor connection. After the connection has cooled, slide the grommet back into original position. Refer to the Tabular Data Sheet for proper vapor line sizing.
6. Protect the vapor valve with a wet rag and brazed the vapor line connection to the outdoor unit. The nitrogen flow should be exiting the system from the vapor service port connection. After this connection has cooled, remove the nitrogen source from the liquid fitting service port.
7. Replace the Schrader core in the liquid and vapor valves.
8. Go to "SECTION IV" for TXV installation.
9. Leak test all refrigerant piping connections including the service port flare caps to be sure they are leak tight. DO NOT OVERTIGHTEN (between 40 and 60 inch - lbs. maximum).
10. Evacuate the vapor line, evaporator and the liquid line, to 500 microns or less.

NOTE: Line set and indoor coil can be pressurized to 250 psig with dry nitrogen and leak tested with a bubble type leak detector. Then release the nitrogen charge.

NOTE: Do not use the system refrigerant in the outdoor unit to purge or leak test.

11. Replace cap on service ports. Do not remove the flare caps from the service ports except when necessary for servicing the system.

CAUTION

Do not connect manifold gauges unless trouble is suspected. Approximately 3/4 ounce of refrigerant will be lost each time a standard manifold gauge is connected.

12. Release the refrigerant charge into the system. Open both the liquid and vapor valves by removing the plunger cap and with an allen wrench back out counter-clockwise until valve stem just touches the chamfered retaining wall. See Page 4 "PRECAUTIONS DURING BRAZING SERVICE VALVE".
13. Replace plunger cap finger tight, then tighten an additional 1/12 turn (1/2 hex flat). Cap must be replaced to prevent leaks.

⚠ WARNING

Never attempt to repair any brazed connections while the system is under pressure. Personal injury could result.

See "System Charge" section for checking and recording system charge.

SECTION IV: INSTALLATIONS REQUIRING TXV

For installations requiring a TXV, the following are the basic steps for installation. For detailed instructions, refer to the Installation Instructions accompanying the TXV kit.

Install TXV kit as follows:

1. First, relieve the holding charge by depressing the Schrader valve located in the end of the liquid line.
2. After holding charge is completely discharged, loosen and remove the liquid line fitting from the orifice distributor assembly. Note that the fitting has **right hand threads**.
3. Remove the orifice from the distributor body using a small diameter wire or paper clip. Orifice is not used when the TXV assembly is installed.
4. After orifice is removed, install the thermal expansion valve to the orifice distributor assembly with supplied fittings. Hand tighten and turn an additional 1/8 turn to seal. Do not overtighten fittings.
5. Reinstall the liquid line to the top of the thermal expansion valve. Hand modify the liquid line to align with casing opening.
6. Install the TXV equalizer line into the vapor line as follows:
 - a. Select a location on the vapor line for insertion of the equalizer line which will not interfere with TXV bulb placement.
 - b. Use an awl to punch through the suction tube and insert the awl to a depth to achieve a 1/8" diameter hole.
7. Install TXV equalizer line in 1/8" hole previously made in vapor line. Equalizer line should not be bottomed out in vapor line. Insert equalizer line at least 1/4" in the vapor line. Braze equalizer line making sure that tube opening is not brazed closed.

⚠ CAUTION

Dry nitrogen should always be supplied through the tubing while it is being brazed, because the temperature required is high enough to cause oxidation of the copper unless an inert atmosphere is provided. The flow of dry nitrogen should continue until the joint has cooled. Always use a pressure regulator and safety valve to insure that only low pressure dry nitrogen is introduced into the tubing. Only a small flow is necessary to displace air and prevent oxidation.

All connections to be brazed are copper-to-copper and should be brazed with a phosphorous-copper alloy material such as Silfos-5 or equivalent. DO NOT use soft solder.

Install the TXV bulb to the vapor line near the equalizer line, using the two bulb clamps furnished with the TXV assembly. Ensure the bulb is making maximum contact. Refer to TXV installation instruction for view of bulb location.

⚠ CAUTION

In all cases, mount the TXV bulb after vapor line is brazed and has had sufficient time to cool.

- a. Bulb should be installed on a horizontal run of the vapor line if possible. On lines under 7/8" OD the bulb may be installed on top of the line. With 7/8" OD and over, the bulb should be installed at the position of about 2 or 10 o'clock.

- b. If bulb installation is made on a vertical run, the bulb should be located at least 16 inches from any bend, and on the tubing sides opposite the plane of the bend. The bulb should be positioned with the bulb tail at the top, so that the bulb acts as a reservoir.
- c. Bulb should be insulated using thermal insulation provided to protect it from the effect of the surrounding ambient temperature.

SECTION V: ELECTRICAL CONNECTIONS

GENERAL INFORMATION & GROUNDING

Check the electrical supply to be sure that it meets the values specified on the unit nameplate and wiring label.

Power wiring, control (low voltage) wiring, disconnect switches and over current protection must be supplied by the installer. Wire size should be sized per NEC requirements.

⚠ CAUTION

*All field wiring must **USE COPPER CONDUCTORS ONLY** and be in accordance with Local, National Fire, Safety & Electrical Codes. This unit must be grounded with a separate ground wire in accordance with the above codes.*

The complete connection diagram and schematic wiring label is located on the inside surface of the unit service access panel and this instruction.

FIELD CONNECTIONS POWER WIRING

1. Install the proper size weatherproof disconnect switch outdoors and within sight of the unit.
2. Remove the screws at the bottom of the corner cover. Slide corner cover down and remove from unit. See Figure 5.
3. Run power wiring from the disconnect switch to the unit.
4. Remove the service access panel to gain access to the unit wiring. Route wires from disconnect through power wiring opening provided and into the unit control box.
5. Install the proper size time-delay fuses or circuit breaker, and make the power supply connections.
6. Energize the crankcase heater if equipped to save time by pre-heating the compressor oil while the remaining installation is completed.

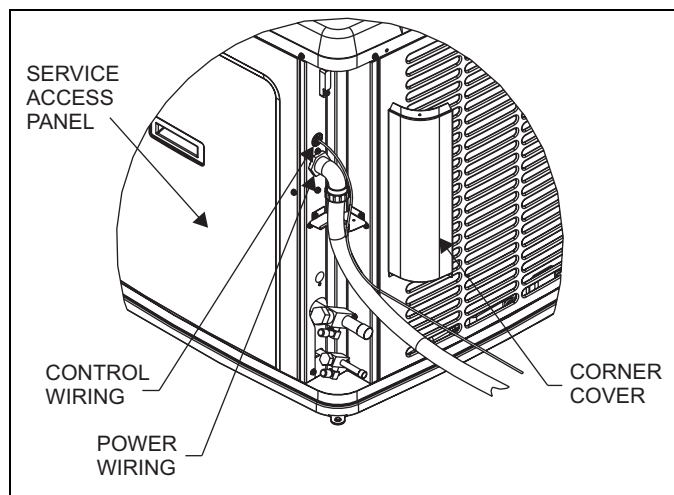

FIGURE 5: Typical Field Wiring

FIELD CONNECTIONS CONTROL WIRING

1. Route low voltage wiring into bottom of control box as shown in Figure 5. Make low voltage wiring connections inside the junction box per Figures 7 - 12.
2. The complete connection diagram and schematic wiring label is located on the inside surface of the unit service access panel.
3. Replace the corner cover and service access panel that were removed in Steps 2 and 4 of the "Field Connections Power Wiring" section.
4. All field wiring to be in accordance with national electrical codes (NEC) and/or local-city codes.
5. Mount the thermostat about 5 ft. above the floor, where it will be exposed to normal room air circulation. Do not place it on an outside wall or where it is exposed to the radiant effect from exposed glass or appliances, drafts from outside doors or supply air grilles.
6. Route the 24-volt control wiring (NEC Class 2) from the outdoor unit to the indoor unit and thermostat.

NOTE: To eliminate erratic operation, seal the hole in the wall at the thermostat with permagum or equivalent to prevent air drafts affecting the operation of in the thermostat.

DEHUMIDIFICATION CONTROL

A dehumidification control accessory 2HU06700124 may be used with variable speed air handlers or furnaces in high humidity areas. This control works with the variable speed indoor unit to provide cooling at a reduced air flow, lowering evaporator temperature and increasing latent capacity. The humidistat in this control opens the humidistat contacts on humidity rise. To install, refer to instructions packaged with the accessory and Figures 7 - 12. Prior to the installation of the dehumidification control, the jumper across the HUMIDISTAT terminals on the indoor variable speed air handler or furnace CFM selection board must be removed.

During cooling, if the relative humidity in the space is higher than the desired set point of the dehumidification control, the variable speed

blower motor will operate at lower speed until the dehumidification control is satisfied. A 40-60% relative humidity level is recommended to achieve optimum comfort.

If a dehumidification control is installed, it is recommended that a minimum air flow of 325 cfm/ton be supplied at all times.

CFM SELECTION BOARD SETTINGS

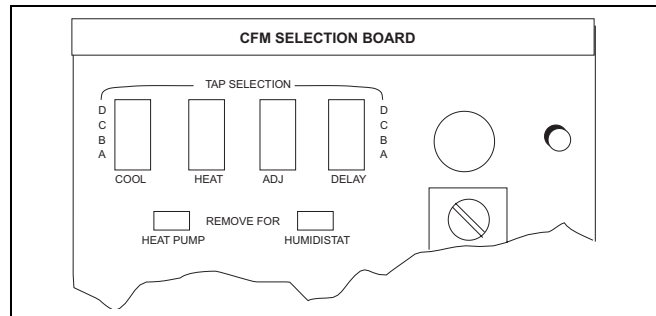

FIGURE 6: CFM Selection Board

For proper system operation the CFM Selection Board jumpers must be set properly.

Refer to the Tabular Data Sheet for the recommended air flow settings for each size condensing unit.

Set the cooling speed per the instructions for the air handler or furnace by selecting the correct COOL and ADJ taps. Verify the airflow using the LED display on the CFM selection board.

The HEAT PUMP jumper **MUST** be removed or in the "YES" position for proper system operation.

The HUMIDISTAT jumper must also be removed or in the "YES" position if a dehumidistat is installed.

For additional connection diagrams for all UPG equipment refer to "Low Voltage System Wiring" document available online at www.upgnet.com in the Product Catalog Section.

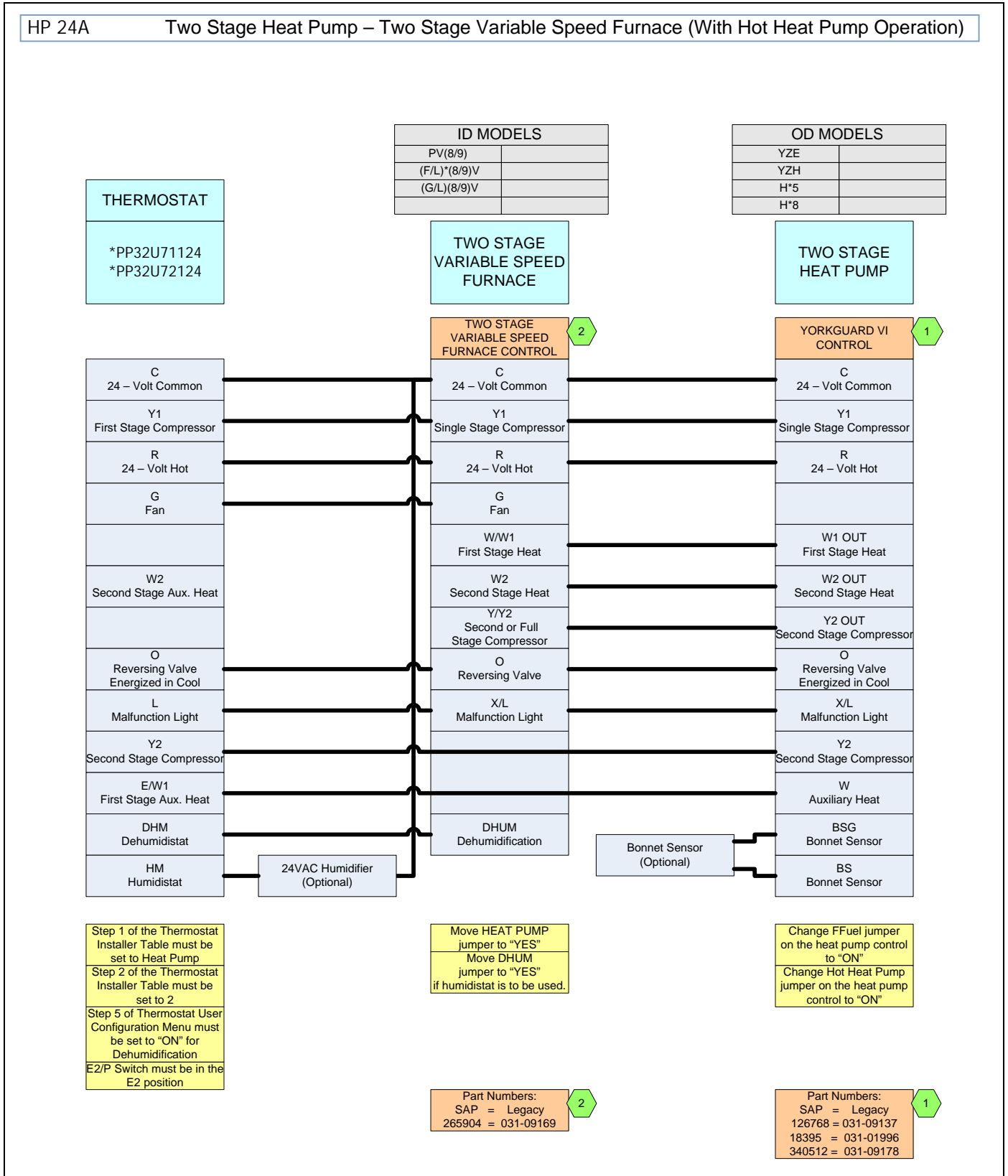

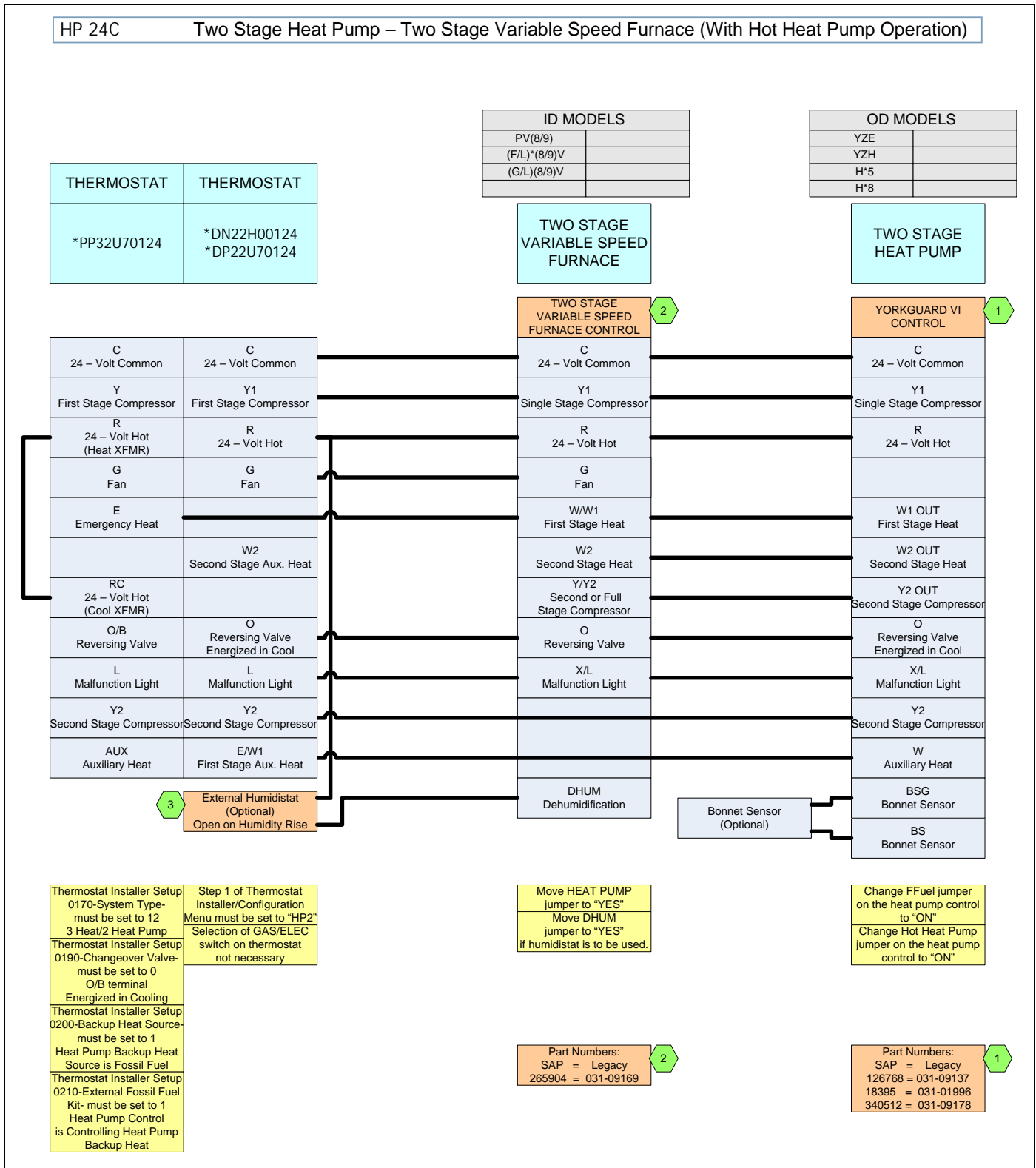

FIGURE 8: Thermostat Wiring – Two-Stage Heat Pump - Two-Stage Variable Speed Furnaces

HP 27A Two Stage Heat Pump – Variable Speed Air Handler (With Hot Heat Pump Operation)

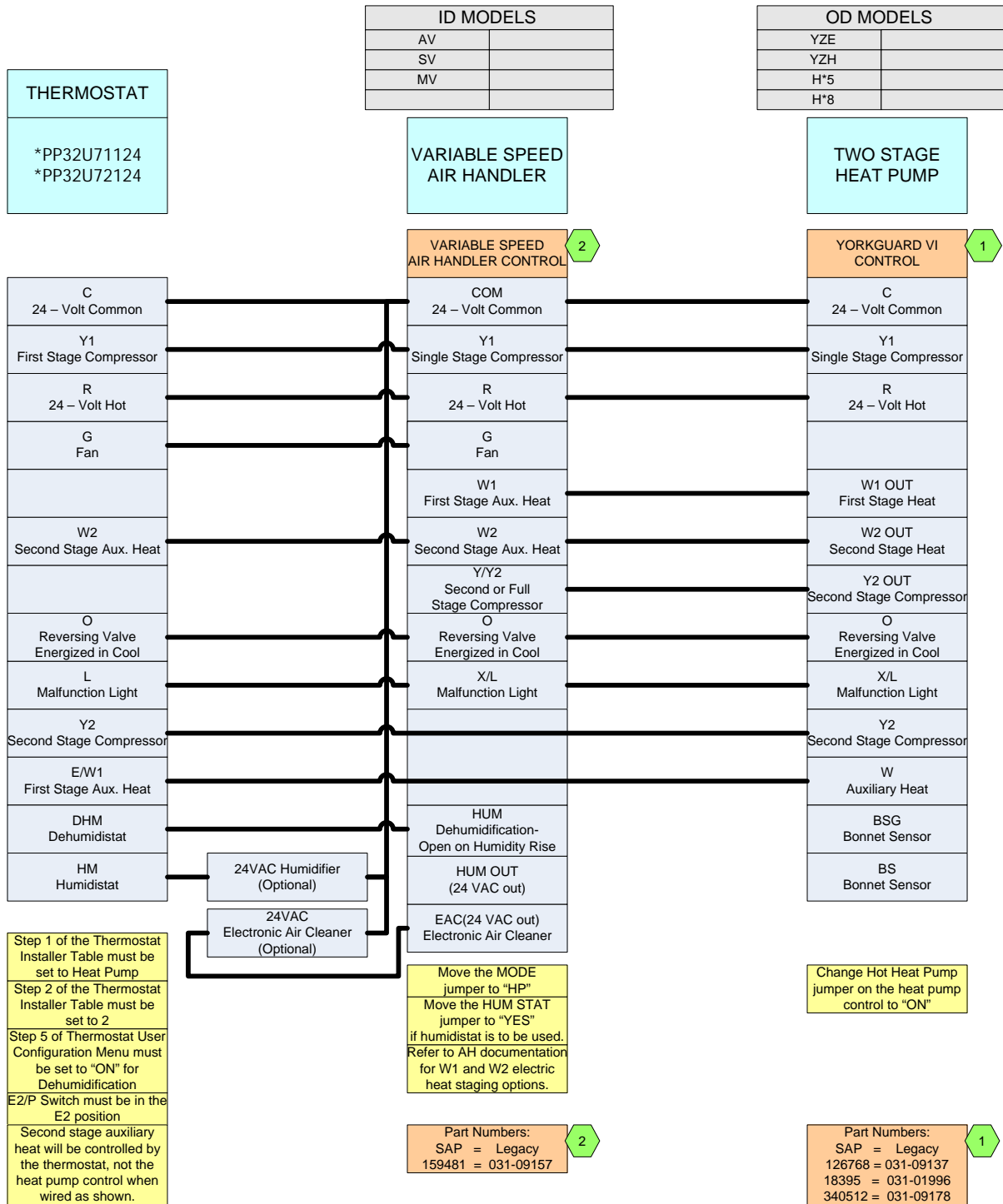

FIGURE 9: Thermostat Wiring – Two-Stage Heat Pump - Variable Speed Air Handler

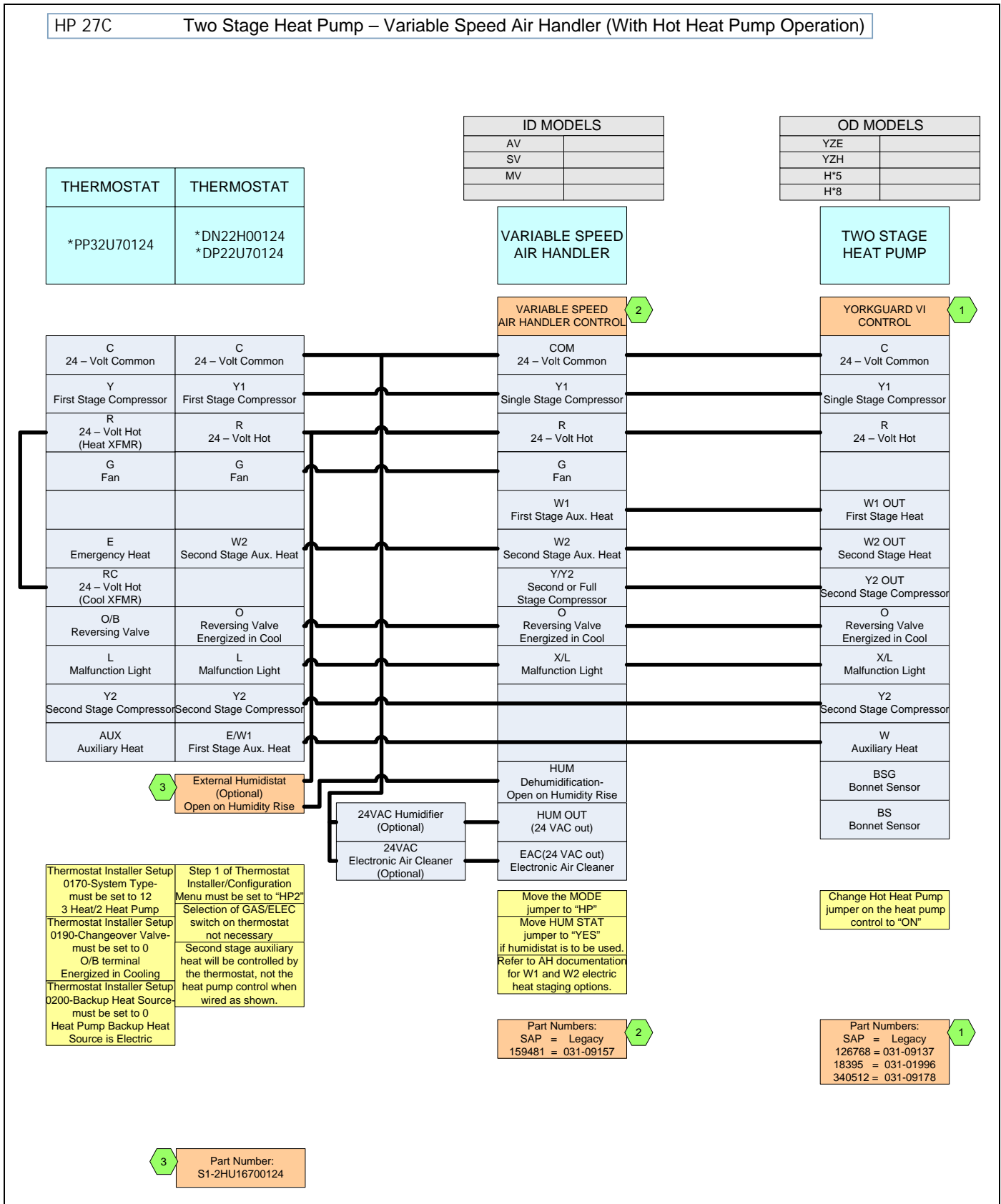

FIGURE 10: Thermostat Wiring – Two-Stage Heat Pump - Variable Speed Air Handler

HP 28A Two Stage Heat Pump – Variable Speed Modulating Furnace (With Hot Heat Pump Operation)

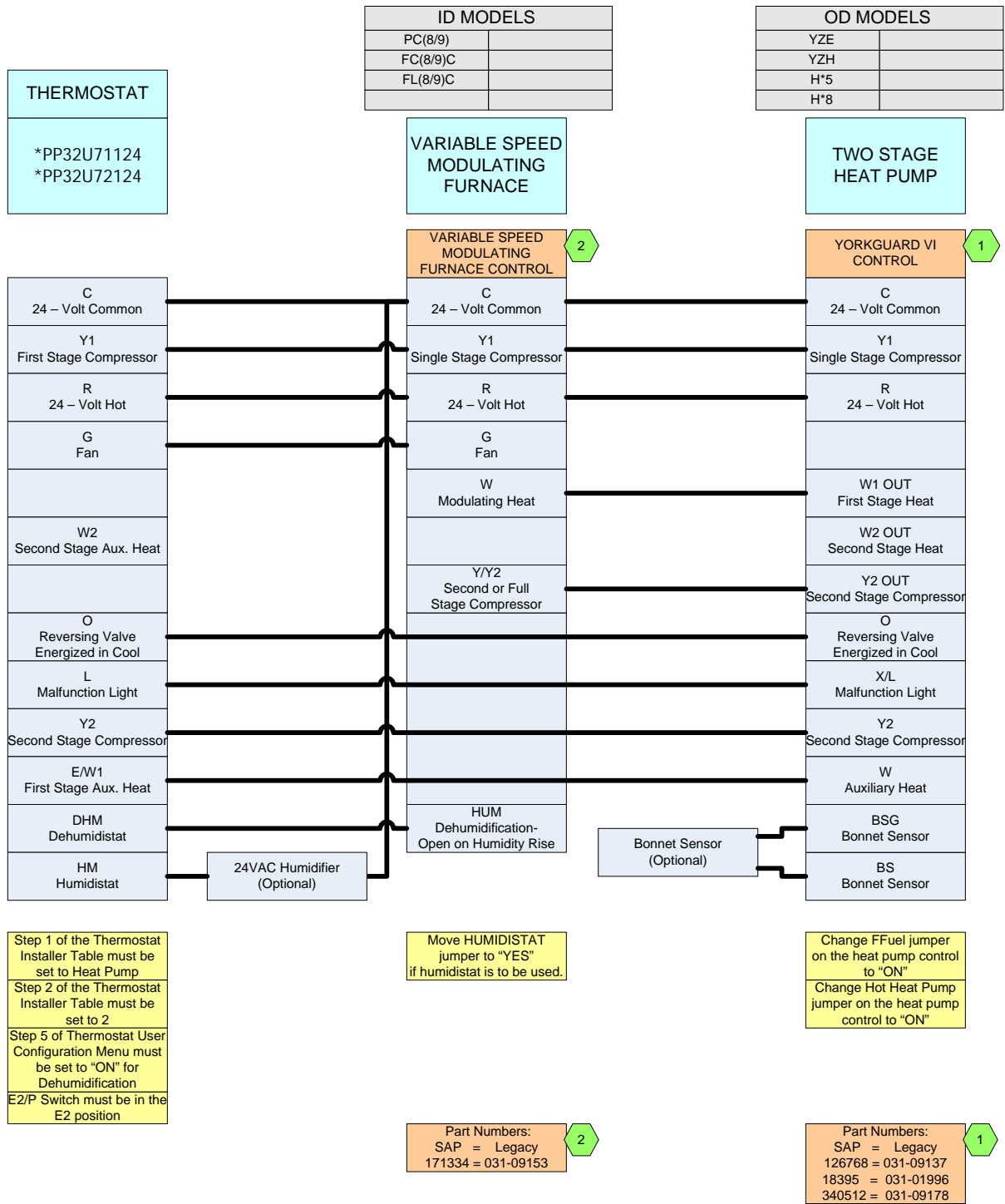
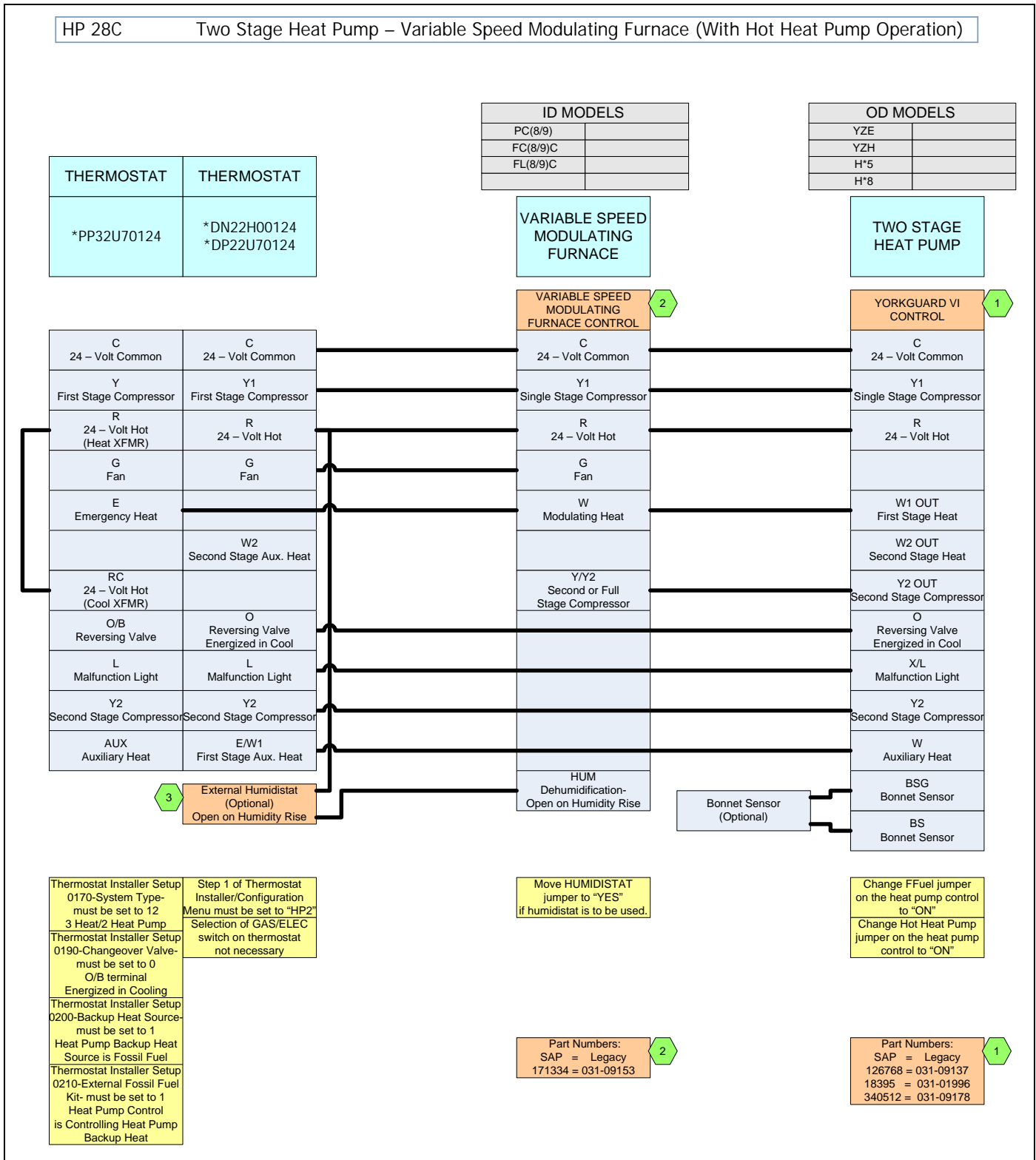

FIGURE 11: Thermostat Wiring – Two-Stage Heat Pump - Variable Speed Modulating Furnace



SECTION VI: EVACUATION

It will be necessary to evacuate the system to 500 microns or less. If a leak is suspected, leak test with dry nitrogen to locate the leak. Repair the leak and test again.

To verify that the system has no leaks, simply close the valve to the vacuum pump suction to isolate the pump and hold the system under vacuum. Watch the micron gauge for a few minutes. If the micron gauge indicates a steady and continuous rise, it's an indication of a leak. If the gauge shows a rise, then levels off after a few minutes and remains fairly constant, it's an indication that the system is leak free but still contains moisture and may require further evacuation if the reading is above 500 microns.

SECTION VII: SYSTEM CHARGE

CAUTION

R-410A refrigerant cylinders are rose colored, and have a dip tube which allows liquid to flow out of the cylinder in the **Upright Position**. Always charge the system slowly with the tank in the upright position.

The factory charge in the outdoor unit includes enough charge for the unit, a 15 ft. line set and the smallest rated indoor coil match-up. Some indoor coil matches may require additional charge. See tabular data sheet provided in unit literature packet for charge requirements.

CAUTION

Do not leave the system open to the atmosphere. Unit damage could occur due to moisture being absorbed by the POE oil in the system. This type of oil is highly susceptible to moisture absorption.

The "TOTAL SYSTEM CHARGE" must be permanently stamped on the unit data plate.

Total system charge is determined as follows:

1. Determine outdoor unit charge from tabular data sheet.
2. Determine indoor coil adjustment from tabular data sheet.
3. Calculate the line charge using the tabular data sheet if line length is greater than 15 feet.
4. Total system charge = item 1 + item 2 + item 3.
5. Permanently stamp the unit data plate with the total amount of refrigerant in the system.

Use the following subcooling charging method whenever additional refrigerant is required for the system charge. A superheat charging method is not suitable for TXV equipped systems.

CAUTION

Refrigerant charging should only be carried out by a qualified air conditioning contractor.

Measurement Method

If a calibrated charging cylinder or accurate weighing device is available, add refrigerant accordingly.

CAUTION

Compressor damage will occur if system is improperly charged. On new system installations, charge system per tabular data sheet for the matched coil and follow guidelines in this instruction.

Check flare caps on service ports to be sure they are leak tight. DO NOT OVERTIGHTEN (between 40 and 60 inch - lbs. maximum).

Subcooling Charging Method

For the **heating operation**, there is no accurate subcooling method for charging the unit. If unit charging is required during heating operation, the unit must be evacuated and charge weighed-in per the marking on the rating plate.

For the **cooling operation**, the recommended subcooling is typically around 10°F. This may vary greatly based on each unique system.

1. Set the system running in the cooling mode by setting the thermostat at least 6°F below the room temperature.
2. Operate the system for a minimum of 15-20 minutes.
3. Refer to the tabular data sheet for the recommended airflow and verify this indoor airflow (it should be about 400 SCFM per ton).
4. Measure the liquid refrigerant pressure P and temperature T at the service valve.
5. Calculate the saturated liquid temperature ST from Table 2 on the last page of this document.
6. Subcooling temperature TC = Saturated Temperature (ST) - Liquid Temp (T).

Example: The pressure P and temperature T measured at the liquid service port is 360 Psig and 93°F. From Table 2, the saturated temperature for 360 Psig is 109°. The subcooling temperature TC = 109° - 93° = 16°F

Add charge if the calculated subcooling temperature TC in Step 6 is lower than the recommended level. Remove and recover the refrigerant if the subcooling TC is higher than the recommended level.

See rating plate for unit specific subcooling chart.

See Figure 13 to trace the flow of refrigerant through the system.

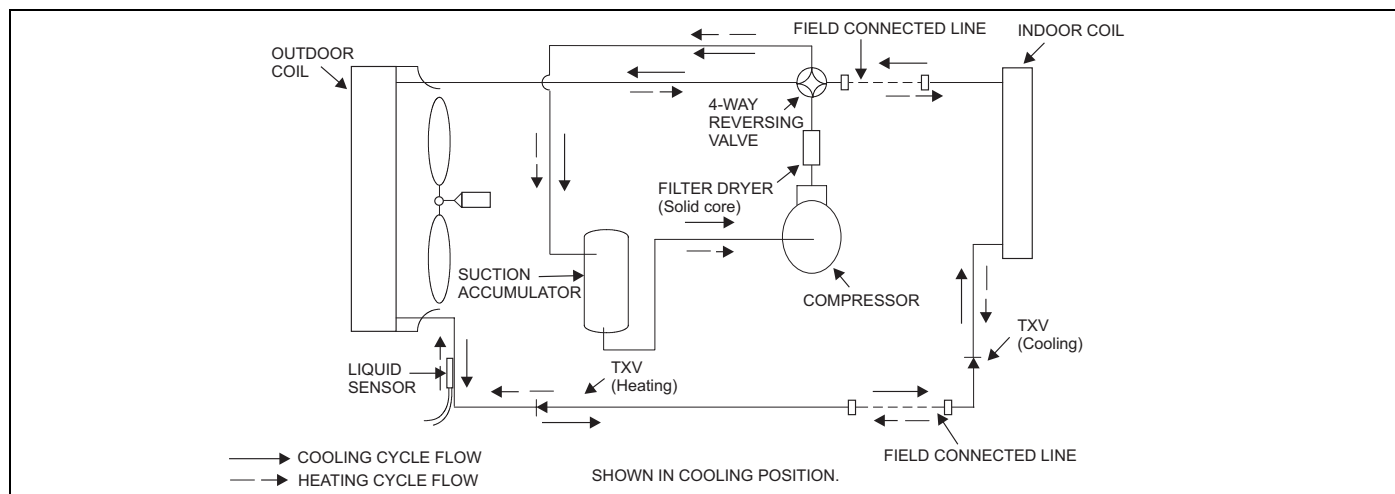

FIGURE 13: Heat Pump Flow Diagram

SECTION VIII: SYSTEM OPERATION

For more information on the control operation, refer to "Operation Instructions - DEMAND DEFROST CONTROL BOARD in this Booklet.

REQUIRED CONTROL SETUP

IMPORTANT: The following steps must be taken at the time of installation to insure proper system operation.

1. Consult system wiring diagram to determine proper thermostat wiring for your system.
2. If hot heat pump configuration is desired, change HOT HEAT PUMP jumper to ON position.
3. If installation includes a fossil fuel furnace, change FFUEL jumper to ON position.
4. Set low temperature cutout (LTCO), balance point (BP), switch point (SP), and Y2 Lock jumpers as desired.
5. Verify proper system functionality. Confirm room thermostat operation including fault code display capability.
6. Upon completion of installation, verify that no fault codes are stored in memory. Clear the fault code memory if necessary.

DEFROST OPERATION

The following defrost curve selection jumper positions are set from factory.

TABLE 1: Defrost Initiate Curves

Defrost Curve Selection Jumper Position	1	2	3	4
Heat Pump Model	N/A	N/A	3 Ton	N/A

INDICATIONS OF PROPER OPERATION

Cooling

Cooling operation is the same as any conventional air conditioning unit.

1. The outdoor fan should be running, with warm air being discharged from the top of the unit.
2. The indoor blower (furnace or air handler) will be operating, discharging cool air from the ducts. Coils or other parts in the air circuit should be cleaned as often as necessary to keep the unit clean. Use a brush, vacuum cleaner attachment, or other suitable means.
3. The vapor line at the outdoor unit will feel cool to the touch.
4. The liquid line at the outdoor unit will feel warm to the touch.

Heating

Indications of proper Heating operation is as follows:

1. The outdoor fan should be running, with cool air being discharged from the top of the unit.

2. The indoor blower (furnace or air handler) will be operating, discharging warm air from the ducts.
3. The vapor line at the outdoor unit will feel warm to the touch.
4. The liquid line at the outdoor unit will feel cool to the touch.

SECTION IX: INSTRUCTING THE OWNER

Assist owner with processing warranty cards and/or online registration. Review Owners Guide and provide a copy to the owner and guidance on proper operation and maintenance. Instruct the owner or the operator how to start, stop and adjust temperature setting.

When applicable, instruct the owner that the compressor is equipped with a crankcase heater to prevent the migration of refrigerant to the compressor during the "OFF" cycle. The heater is energized only when the unit is not running. If the main switch is disconnected for long periods of shut down, do not attempt to start the unit until 8 hours after the switch has been connected. This will allow sufficient time for all liquid refrigerant to be driven out of the compressor.

The installer should also instruct the owner on proper operation and maintenance of all other system components.

MAINTENANCE

1. Dirt should not be allowed to accumulate on the outdoor coils or other parts in the air circuit. Clean as often as necessary to keep the unit clean. Use a brush, vacuum cleaner attachment, or other suitable means.
2. The outdoor fan motor is permanently lubricated and does not require periodic oiling.
3. If the coil needs to be cleaned, it should be washed with Calgon Coilclean (mix one part Coilclean to seven parts water). Allow solution to remain on coil for 30 minutes before rinsing with clean water. Solution should not be permitted to come in contact with painted surfaces.
4. Refer to the furnace or air handler instructions for filter and blower motor maintenance.
5. The indoor coil and drain pan should be inspected and cleaned regularly to prevent odors and assure proper drainage.

CAUTION

IT IS UNLAWFUL TO KNOWINGLY VENT, RELEASE OR DISCHARGE REFRIGERANT INTO THE OPEN AIR DURING REPAIR, SERVICE, MAINTENANCE OR THE FINAL DISPOSAL OF THIS UNIT.

WHEN THE SYSTEM IS FUNCTIONING PROPERLY AND THE OWNER HAS BEEN FULLY INSTRUCTED, SECURE THE OWNER'S APPROVAL.

TABLE 2: R-410A Saturation Properties

TEMP. °F	PRESSURE PSIG	TEMP. °F	PRESSURE PSIG	TEMP. °F	PRESSURE PSIG	TEMP. °F	PRESSURE PSIG	TEMP. °F	PRESSURE PSIG
45	129.70	60	169.60	75	217.40	90	274.10	105	340.50
46	132.20	61	172.60	76	220.90	91	278.20	106	345.30
47	134.60	62	175.50	77	224.40	92	282.30	107	350.10
48	137.10	63	178.50	78	228.00	93	286.50	108	355.00
49	139.60	64	181.60	79	231.60	94	290.80	109	360.00
50	142.20	65	184.60	80	235.30	95	295.10	110	365.00
51	144.80	66	187.70	81	239.00	96	299.40	111	370.00
52	147.40	67	190.90	82	242.70	97	303.80	112	375.10
53	150.10	68	194.10	83	246.50	98	308.20	113	380.20
54	152.80	69	197.30	84	250.30	99	312.70	114	385.40
55	155.50	70	200.60	85	254.10	100	317.20	115	390.70
56	158.20	71	203.90	86	258.00	101	321.80	116	396.00
57	161.00	72	207.20	87	262.00	102	326.40	117	401.30
58	163.90	73	210.60	88	266.00	103	331.00	118	406.70
59	166.70	74	214.00	89	270.00	104	335.70	119	412.20

SECTION X: WIRING DIAGRAM

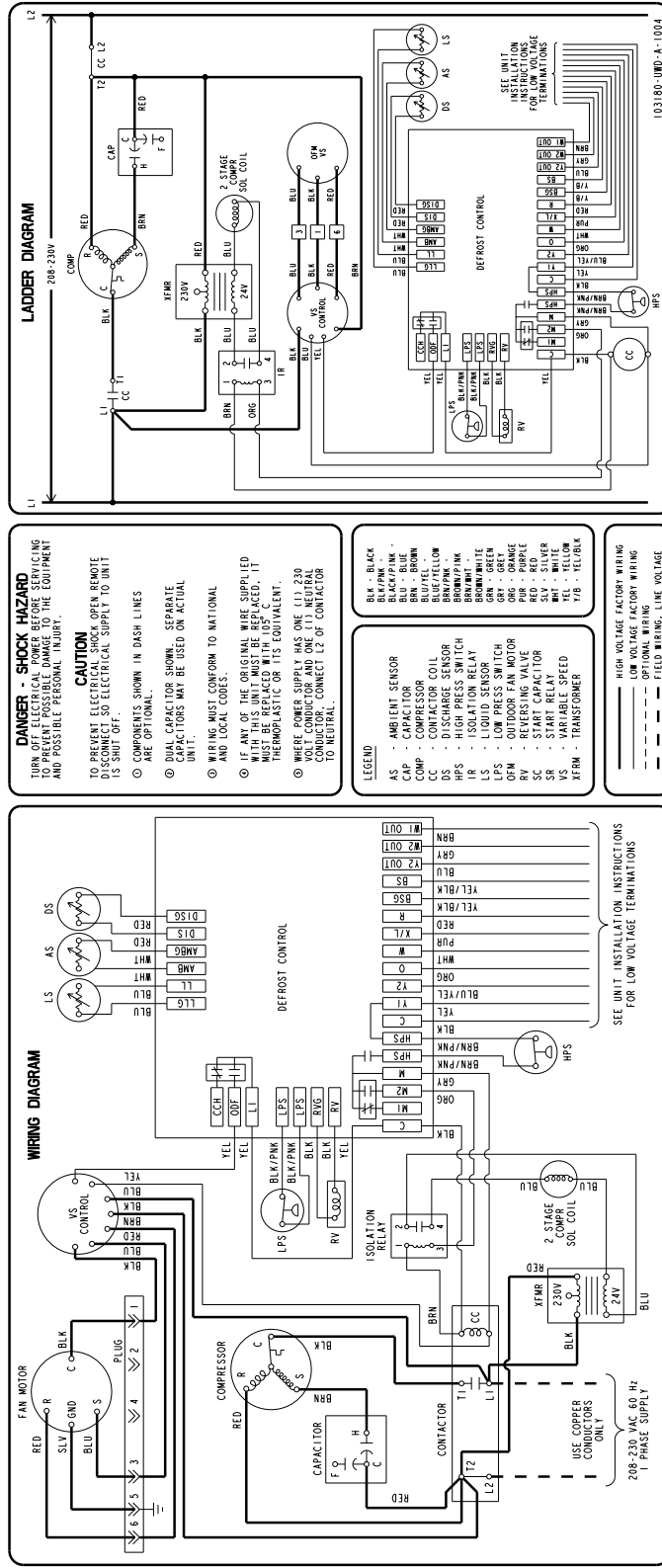

FIGURE 14: Wiring Diagram

