

*Dear Customer,*

*Thank you for choosing a Teuco Minipool.*

*A generous and versatile range of jets, an incomparable set of functions leaving you free to enjoy different kinds of relaxation, from toning massages to hydrotherapy, that will revitalize those delicate areas of the body like the neck, back, legs and feet.*

*Combating stress and recapturing well-being has never been easier.*

## CONTENTS

<b>INTRODUCTION</b> .....	18
- USE AND MAINTENANCE MANUAL	
- TEUCO QUALITY	
- USEFUL HINTS ON PROPER USE OF THE WHIRLPOOL	
- SAFETY GUIDELINES	
<b>INSTRUCTIONS</b>	
- MINIPOOL FUNCTIONS .....	20
- THE CONTROL PANEL .....	22
- STARTING UP FIRST TIME .....	23
- PUMP 1	
- PUMP 2 .....	24
- AIR JETS	
- SETTING THE WATER TEMPERATURE .....	25
- ECONOMY	
- FILTER .....	26
- FILTER BOOST	
- CLOCK	
- LIGHT .....	27
- CONTROL PANEL LOCKOUT	
- OFF MODE .....	28
- ROTATE DISPLAY	
- TEMPERATURE DISPLAY IN DEGREES CELSIUS OR FAHRENHEIT	
- MINIPOOL CANVAS .....	29
<b>MAINTENANCE</b> .....	30
- CLEANING THE FILTERS	
- CLEANING ACRYLIC PARTS OF THE MINIPOOL	
- WINTERING PROCEDURE	
<b>REPAIRS</b> .....	32
- DIAGNOSTICS MESSAGES	
- REMOVING SCUFFS, SCRATCHES AND CIGARETTE BURNS	

## USE AND MAINTENANCE MANUAL

- *The present manual provides a guide for the safe use of your Teuco Minipool, and must be read carefully before using the product.*
- *This manual constitutes an integral part of the product and must be kept for future reference.*
- *Teuco Guzzini SpA reserves the right to make such changes as are deemed appropriate without prior notice and without any obligation to update.*

## TEUCO QUALITY

*Teuco takes the greatest care over the materials used in its products, making technological improvements continuously both to the plastics utilized, and to details of construction. All Teuco Minipools are fashioned from cast acrylic resin: the frame is zinc-treated steel, and pipelines are of high strength material.*

*Teuco Minipools bear the  mark, indicating that they are designed and manufactured in accordance with the essential requirements of European directives 73/23 - 93/68 on electrical safety and 89/336 - 92/91 - 93/68 on electromagnetic compatibility.*

*The safety of Teuco whirlpool systems is also certified officially by  (Italian Quality Mark Institute) as being in compliance with the application of current European standards.*

## USEFUL HINTS ON PROPER USE OF THE TEUCO MINIPOOL

- Given the relaxing and invigorating effects of a whirlpool massage, doubtless the best time to take a session is after sport or physical exercise, although not on a full stomach and never before food has been properly digested.
- The temperature of the water needs to be around 37 °C to derive maximum benefit from the massage.
- In the case of new users, most especially, whirlpool sessions should be restricted to just a few minutes. Thereafter, the duration can be increased gradually to 15-20 minutes, but always subject to the user's general physical fitness.

## SAFETY

- To ensure the appliance is correctly installed, follow all the instructions in the accompanying installation manual with due care. Incorrect installation may result in injury to persons and animals or damage to property. The manufacturer declines any liability for injury or damage attributable to incorrect installation.
- For proper use of the appliance, follow the instructions given in this manual. This appliance must be used only for the purpose for which it was designed. The manufacturer declines any liability for injury or damage attributable to improper use.
- This product is intended for home use. In the event of a Teuco minipool being commissioned for public use, procurement managers must ensure compliance with all statutory regulations governing safety, water treatment and utility systems normally in force in the country of installation.
- Only adult persons should use the appliance. Children and the disabled may use the Teuco Minipool under constant supervision. For special cases (the elderly, individuals with high blood pressure or heart disease, pregnant women and people taking cures), seek medical advice before using the whirlpool.
- With the whirlpool system in operation:
  - take care that the suction valves or the skimmer are not obstructed by any object or part of the body, and in particular, keep hair well clear;
  - do not handle fragile objects that could break (e.g. drinking glasses);
  - do not use electrical appliances (e.g. radios, hair dryers, etc.) near the minipool.
- Take care when stepping into or out of the minipool, as water will make all the surfaces slippery.
- Do not use the minipool in unsuitable weather conditions (e.g. during a thunderstorm).
- Do not block the space between the floor and the side panelling, or in the case of the built-in version, do not block the vents in the pool surround.
- In the event of breakdown or malfunction occurring during the warranty period, contact a Teuco technician or approved service centre only. The manufacturer declines any liability for damage or injury caused by appliances that have been tampered with or incorrectly repaired.
- Make certain the cap of the Aromatherapy Essences Dispenser is always fitted. Do not remove the cap from the Dispenser when the AIR JETS are in operation (see AIR JETS).

## MINIPOOL FUNCTIONS

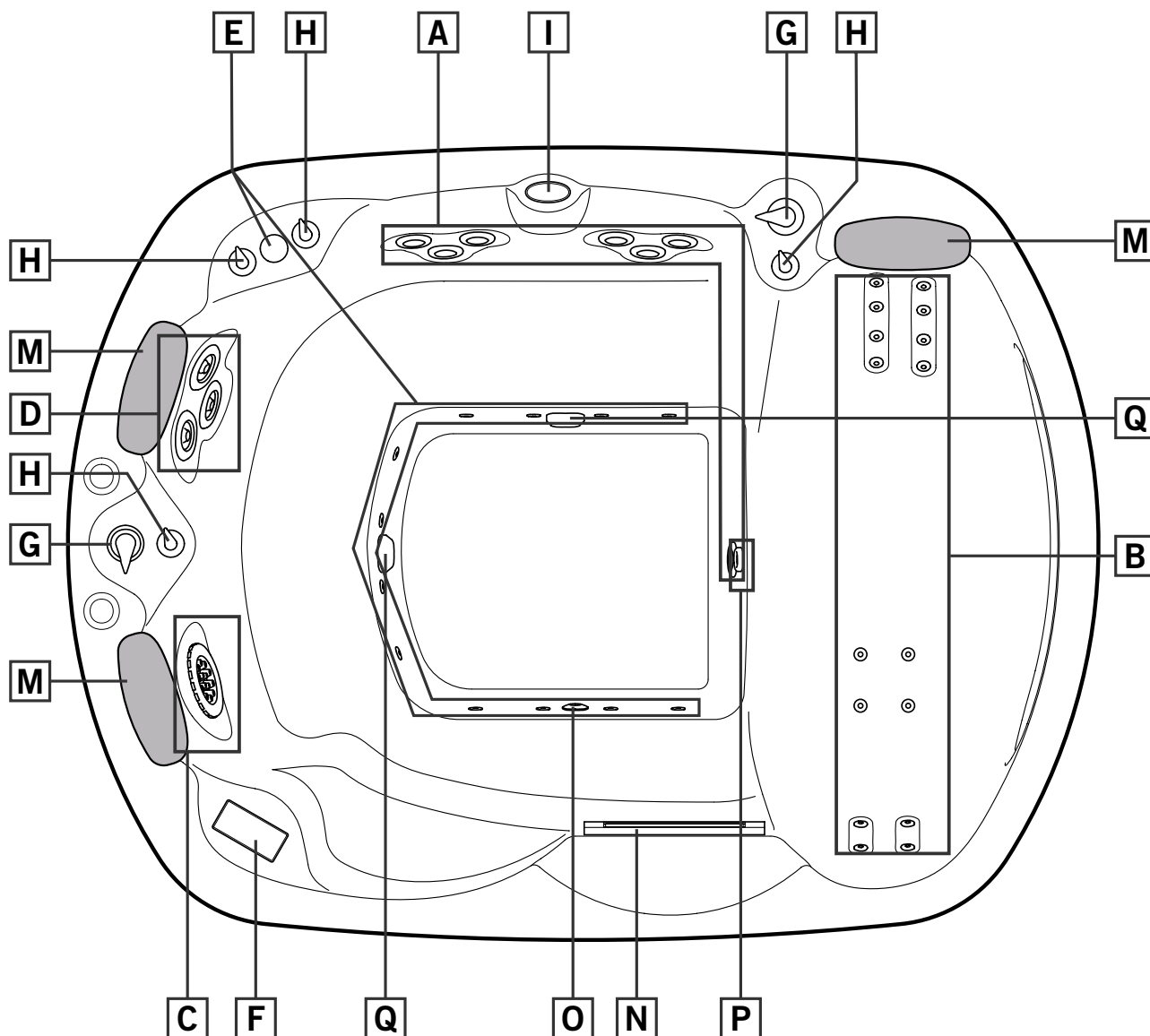

**A - Two Seats:** Each with three Multi Roto Jets massaging the torso and one Roto Jet in the central area of the pool.

**B - Recliner:** Includes sixteen Stream Jets within the seat outline.

**C - Power Jet:** This is the jet with the deepest and strongest massaging action. Its effect is similar to a powerful force of nature, like a waterfall or a racing torrent.

**D - Tri Roto Jet:** Three jets, all adjustable for direction. The two jets uppermost can be rotated to create a special vortex effect; the lower jet is directional, like a high flow whirlpool jet. The rate of flow through all three is adjustable simply by turning the outer ring.

**E -Blower:** twelve jets delivering air only, which oxygenate the water and stimulate the skin, giving it vitality. In combination with whirlpool essences (put into the special dispenser), they excite the sense of smell, delivering all the benefits of aromatherapy.

**Aromatherapy:** according to the principles of aromatherapy, perfumed essences not only give immediate pleasure to the sense of smell, they also stimulate receptors in the brain that are able to change our mood for the better, making us calmer, more happy, more focused, depending on our nature. Besides being harmless to the skin, the essences prepared for the Teuco Minipool do not cloud the water and will leave no traces of foam.

**F - Electronic control panel:** an easy-to-use operating system ensuring that selected functions and their settings can be monitored continuously.

**G - Flow diverter:** used to switch the flow of water from one massage of the minipool to another.

**H - Selector knob:** regulates the force of the whirlpool massage by proportioning the amount of air.

**I - Quick start:** ON/OFF buttons used to activate Pump 1, Pump 2, Blower and Underwater Light.

**M - Anatomically contoured headrest:** soft and ergonomically designed cushions ensuring individual occupants of the Teuco Minipool can relax with their head comfortably and correctly positioned.

**N - Skimmer:** draws impurities off the surface of the water and into a special internal filtering system.

**O - Water treatment:** the water in the pool is filtered and disinfected continuously with ozone by a special circuit that remains permanently active, even in the standby condition (electrical system powered up).

Ozone will cease to be generated for a period of 40 minutes whenever any one of the minipool functions is activated.

**P - Underwater light:** the Teuco minipool will be a magnificent sight even after dark, with the underwater light throwing up reflections that ripple on the surface of the water.

**Q - Suction valve ports:** These take water from the tub back into the circuit of the whirlpool system.

## THE CONTROL PANEL

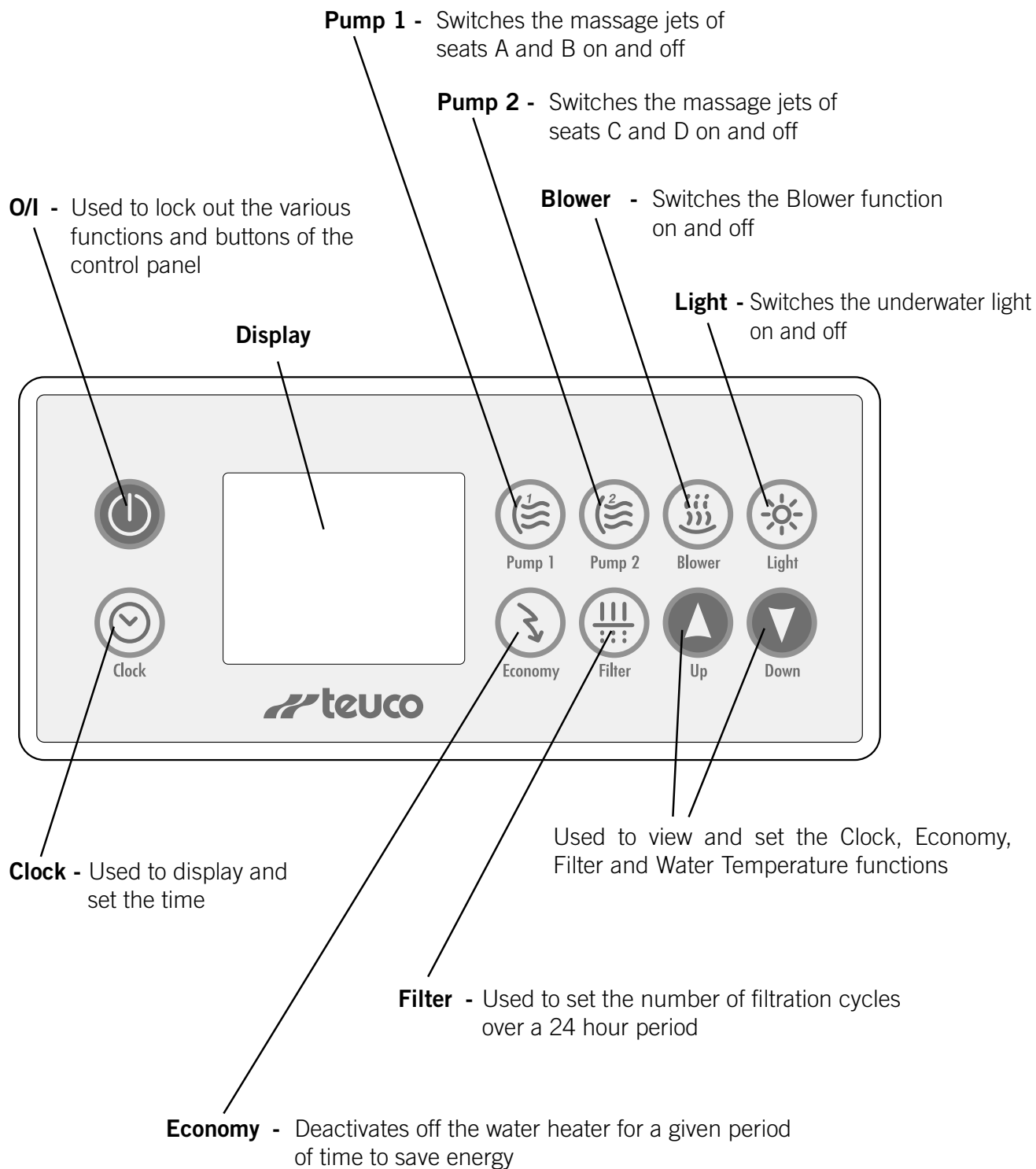

## STARTING UP FIRST TIME

### 1 - REMOVE THE CANVAS FROM THE MINIPOOL

Unhook the retaining straps at the four corners of the pool to remove the canvas.

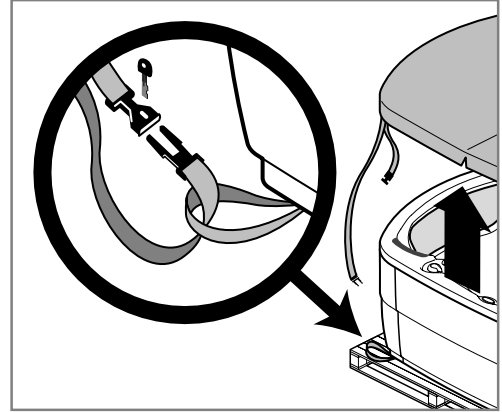

### 2 - FILL THE MINIPOOL

Fill the minipool with water to the level indicated on the skimmer.

The water put into the pool must be no hotter than 35 °C.

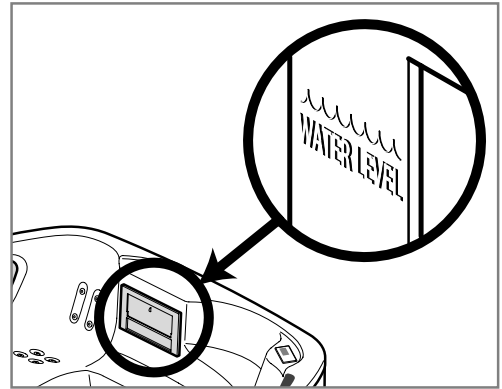

### 3 - POWER UP THE SYSTEM

CAUTION: power up the electrical equipment only after the minipool has been filled with water.

Position the isolating switch (fitted during installation) to ON. Check the smooth operation of the residual current switch, wired up during preinstallation, by pressing the test button. The switch should trip.

Reset the switch following the test.

The recirculation pump will start up automatically.

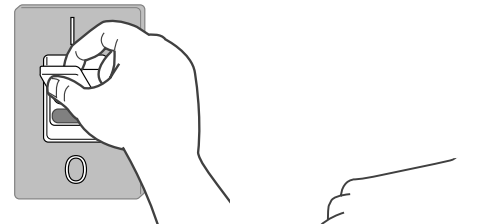

Start up the whirlpool systems by pressing buttons Pump1 and Pump2 at the control panel.

Open all the jets, checking that there are no water leaks from the plumbing connections, and that everything works as it should; the pumps can now be switched off.

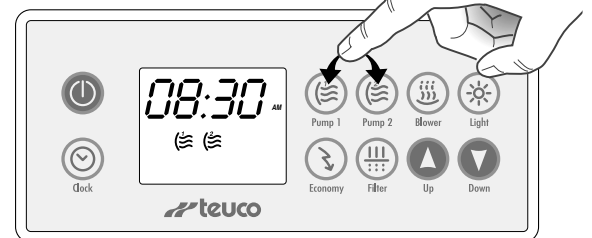

### 4 - WATER TREATMENT

Treat the water using the products supplied by Teuco, as described in the accompanying manual.

Other equivalent proprietary products can also be used.

**Check that the pH value of the water is between 7.2 and 7.6 and the quantity of chlorine between 1 and 1.5 ppm.**

The pH value and Chlorine level must be tested chemically at frequent intervals to guarantee the quality of the water is properly maintained and ensure correct operation of the system.

## PUMP 1

Press the “Pump 1” button to activate the massage of seats A - B.

Press “Pump 1” a second time to switch the function off.

Use the **DIVERTER (G)** to direct all of the flow to seat A or seat B, or part of the flow to each.

Use the selector knobs **(H)** to increase or diminish the power of the jets.

**QUICK START:** the massages of seats A and B can be activated by pressing the remote button on the panel **(I)**.

After 20 minutes continuous operation, the function will switch off automatically.

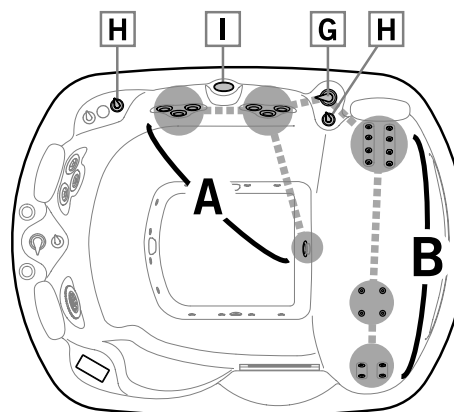
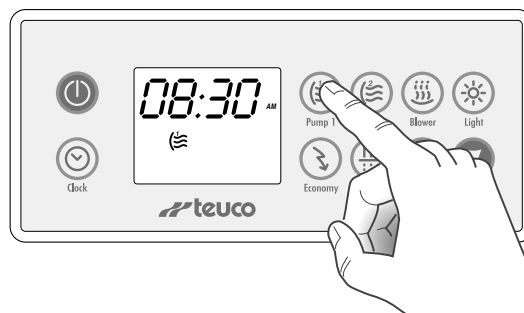

## PUMP 2

Press “Pump 2” to activate the massage of seats C - D.

Press “Pump 2” a second time to switch the function off.

Use the **DIVERTER (G)** to direct all of the flow to seat C or seat D, or part of the flow to each.

Use the selector knobs **(H)** to increase or diminish the power of the jets.

**QUICK START:** the massages of seats C and D can be activated by pressing the remote button on the panel **(I)**.

After 20 minutes continuous operation, the function will switch off automatically.

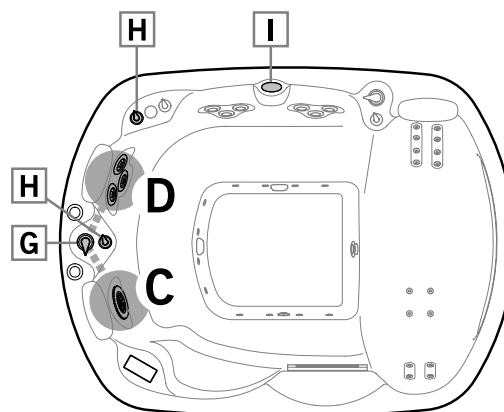
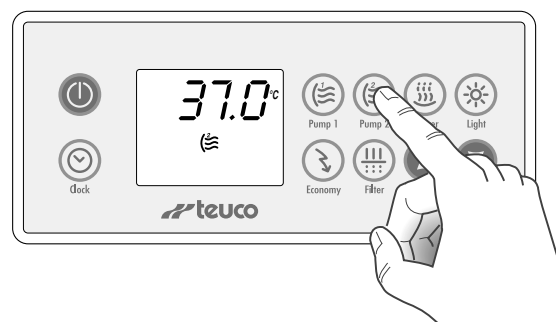

## BLOWER

Press “Blower” to activate the Air jets function at HIGH SPEED.

Press “Blower” a second time to select LOW SPEED.

Press “Blower” a third time to switch the air jets off.

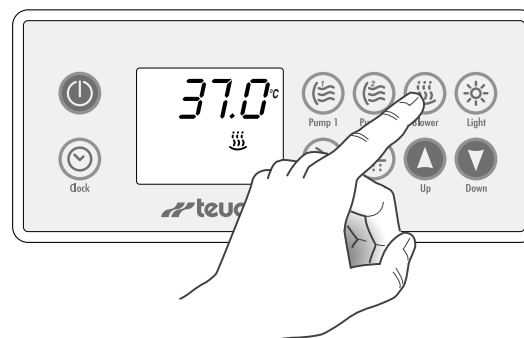

**QUICK START: the Blower can be activated by pressing the remote button on the panel (I).**

After 20 minutes continuous operation, the function will switch off automatically.

## AROMATHERAPY

Teuco supplies essences for use in the minipool: these are non-foaming substances that leave the water crystal clear and will not harm the skin or deface the surfaces of the tub.

The essence is put into the **DISPENSER (E)**, and always with the Air Jet function off.

Unscrew the safety cap, put in the essence and close up again.

Switch on the Air Jet function to mix the essence with the water.

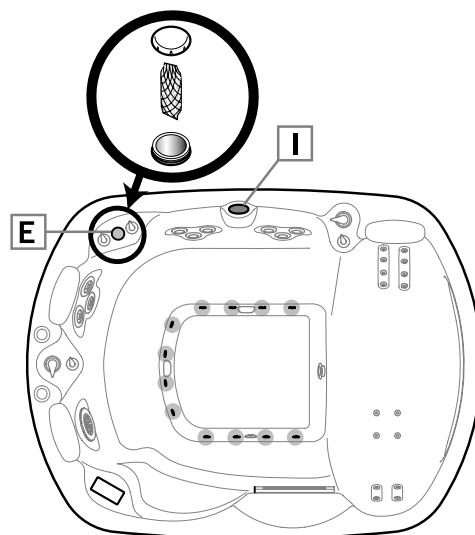

## SETTING THE WATER TEMPERATURE

Use buttons “▲” and “▼” to select the desired temperature of the water in the minipool.

The symbol “” is displayed during the setting procedure.

The temperature can be set between 15 °C and 40 °C

If the temperature of the water in the minipool is lower than the setting, the heater will be activated.

The symbol “” is displayed until the water has been heated to the set temperature.

If other functions are activated when the heater is in operation, the heater may be shut off automatically to limit the power consumed by the minipool.

When the “” symbol blinks in the display, this means that the heater is deactivated temporarily.

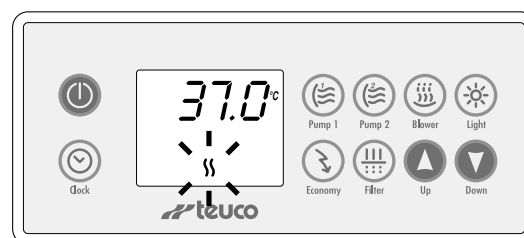
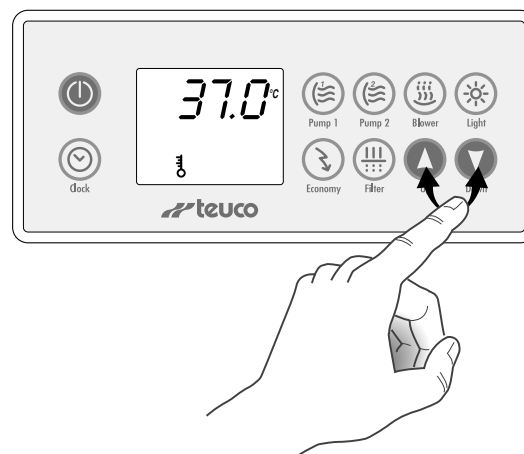



## ECONOMY

This function can be used to programme the deactivation of the heater for a given period of time (e.g. during the night).

Press the “Economy” button a first time to set the duration of the Economy period (when the heater remains off).

The display shows E 00.

Use buttons “▲” and “▼” to set the duration (from 0 to 24 hours).

Press “Economy” a second time to set the delay before the Economy function cuts in (number of hours between the time of programming and the time the Economy period is due to start).

The display shows Ed 00.

Use buttons “▲” and “▼” to set the delay (from 0 to 23 hours).

Press the “Economy” a third time to terminate the programming procedure.

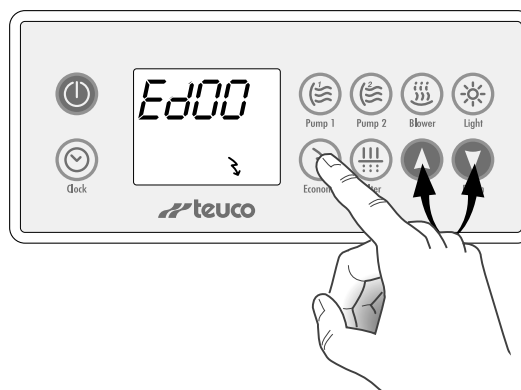
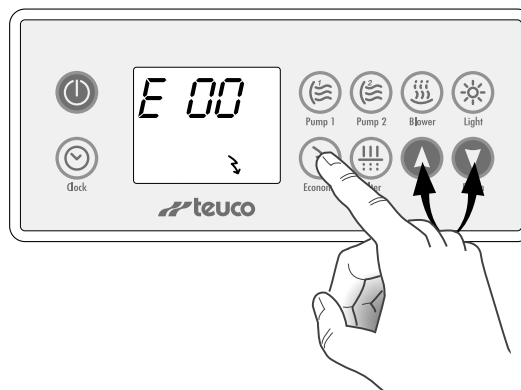

## FILTER

This function is used to programme the number of filtration cycles for the following 24 hours.

Press the “Filter” button; the display shows P 01.

Use buttons “▲” and “▼” to set the number of cycles (1, 2, 3, 4, 6, 8, 12, 24).

- To start the first filtration **immediately** press “Filter” a second time.

The filtration cycle lasts for 2 minutes with activation of the Pump 1, Pump 2 and Blower functions.

- To set the system so that filtration does **not start immediately**, press “Filter”, “▲” and “▼” and hold for 5 seconds.

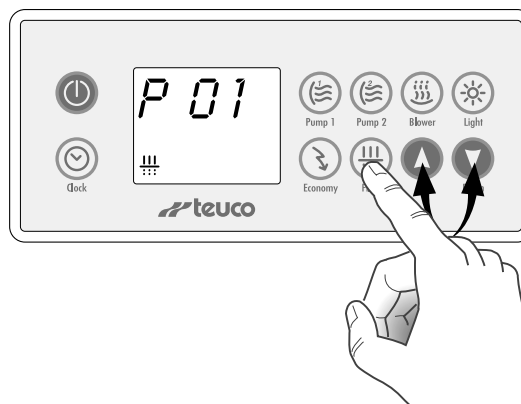

## FILTER BOOST

This function serves advantageously to filter the water following heavy use of the minipool, or to mix the treatment chemicals more quickly.

Press the “Pump 1” button and hold for 5 seconds.

The display shows B 00.

Pump 1 and the ozonator are activated for 45 minutes.

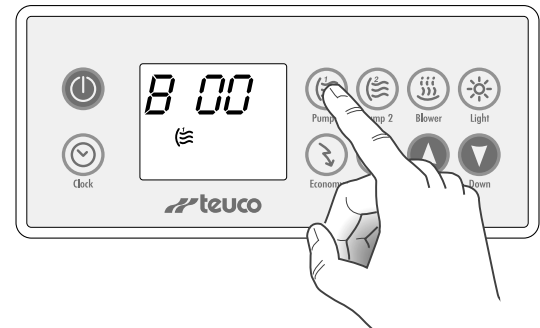

## CLOCK

Press the “Clock” button to display the time.

### SETTING THE EXACT TIME

To set the exact time, press and hold the “Clock” button (the hours field will blink).

Use buttons “▲” and “▼” to set the hours.

Press “Clock” again to set the minutes (the minutes field will blink).

Use buttons “▲” and “▼” to set the minutes.

Press the “Clock” button once more to terminate the setting procedure.

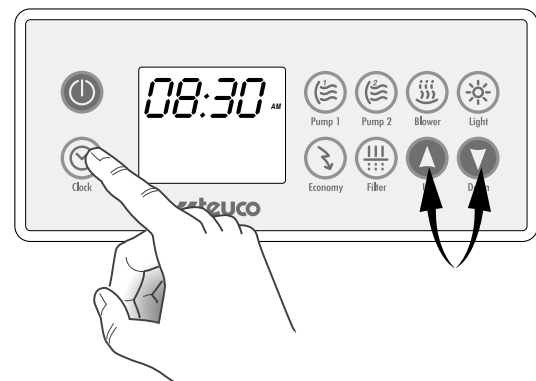

## LIGHT

Press the “Light” button to switch on the underwater light in the minipool.

Press “Light” a second time to switch the underwater light off.

**QUICK START:** the underwater light can be switched on by pressing the remote button on the panel (I).

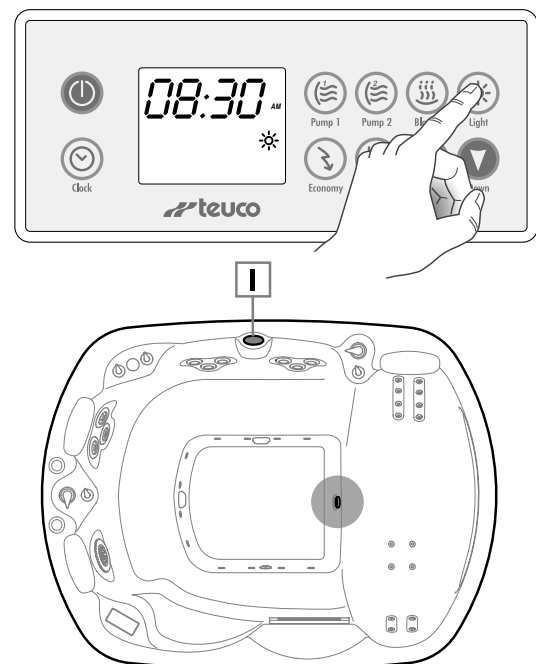

## CONTROL PANEL LOCKOUT

This function can be used to inhibit the operation of some or all of the control panel buttons.

### PARTIAL LOCKOUT:

Press and hold the “Economy” button for 5 seconds to inhibit all functions except Pump 1, Pump 2, Blower and Light.

The display shows “LocP”.

In this situation, the current settings cannot be changed.

To *re-enable* the control panel, press the “Economy” button again and hold for 5 seconds.

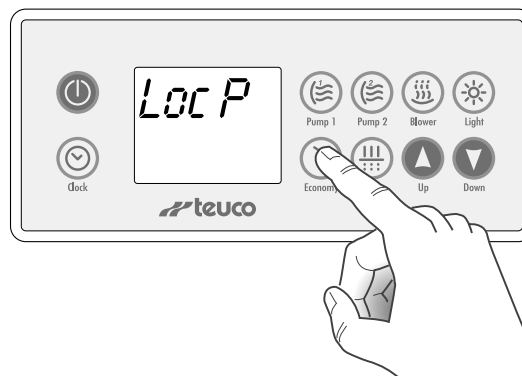

### FULL LOCKOUT:

Press and hold the “Economy” button for 10 seconds to inhibit all functions.

The display shows “LocF”.

In this situation, all buttons are disabled, whereas the recirculation and all programming functions remain active.

To *re-enable* the control panel, press the “Economy” button again and hold for 5 seconds.

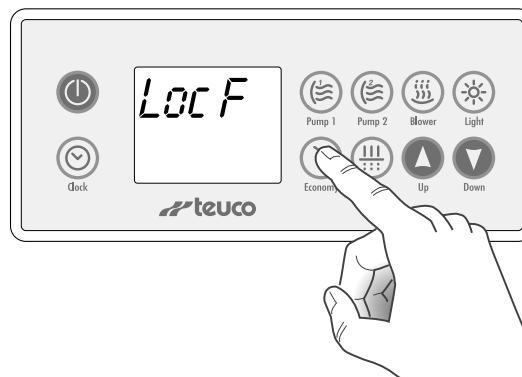

## OFF MODE

Press the “” button and hold for 5 seconds to lock out all functions, recirculation and buttons of the control panel (for a period of 30 minutes).

This is a safety function for use when cleaning the filters or removing foreign matter from the bottom of the pool, or whenever the system needs to be shut off for technical reasons.

To *reactivate* the control panel before 30 minutes have elapsed, press the “” button a second time.

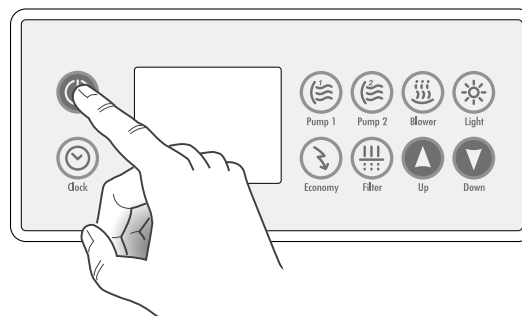

## ROTATE DISPLAY

Messages can be displayed upside down so that they are readable from both inside and outside the minipool.

Press the “Filter” button and hold for 5 seconds to rotate the display 180°.

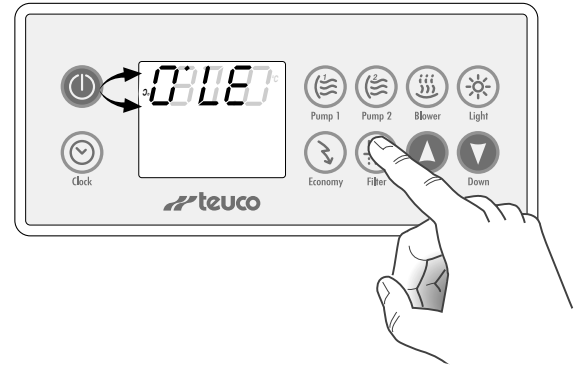

## TEMPERATURE DISPLAY IN DEGREES CELSIUS OR FAHRENHEIT

The temperature of the water can be displayed in degrees Celsius or degrees Fahrenheit.

Press the “Light” button and hold for 5 seconds to display the temperature in °C or °F.

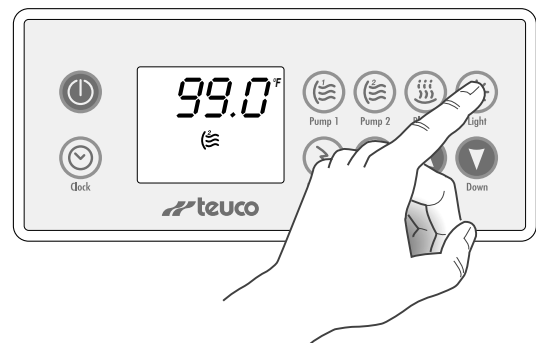

## MINIPOOL CANVAS

Always keep the minipool covered over (when not in use) so as to avoid heat loss and evaporation, and to prevent the water being fouled with leaves and dirt. The canvas must be held down with the straps and, if necessary, locked for added security.

**The canvas is not intended to carry weights.**

**Do not sit, step or lie on the canvas.**

**Do not place objects on the canvas.**

**The canvas can be dangerous if not secured or properly closed.**

**Failure to follow the instructions for securing the canvas can result in danger to the user.**

**Remove the canvas completely before stepping into the pool, otherwise there is a risk of being trapped.**

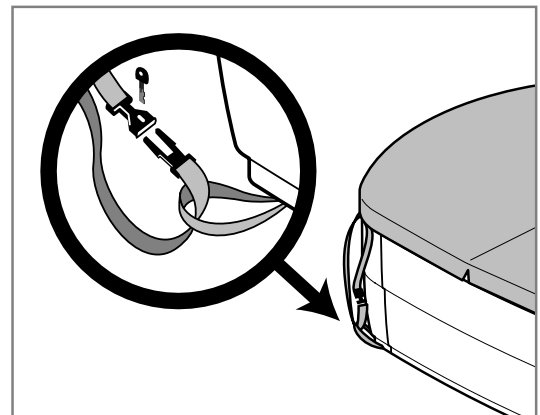

## CLEANING THE SURFACES

Refer to the CLEANING INSTRUCTIONS manual accompanying the product.

## CLEANING THE FILTERS

Every two weeks the message CLE will blink in the display, indicating that the filters need cleaning.

**Clean the filters more often if need be.**

To clean the filters:

- select "OFF MODE" at the control panel,
- remove the cover and tray of the skimmer,
- unscrew the filters and remove them from their sockets.

Clean the filters under a strong jet of water (use a high pressure hose if necessary).

**Replace the filters at the first signs of any deterioration.**

**Replacement filters are available from Teuco Authorized Dealers.**

**Having cleaned or replaced the filters, refit all components before restarting the minipool.**

**To restart the minipool, deselect the "OFF MODE" function at the control panel.**

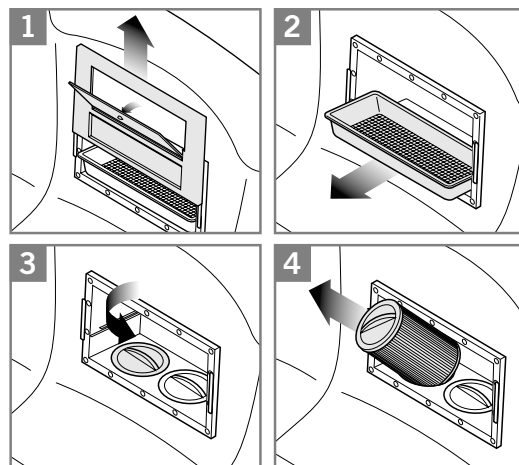
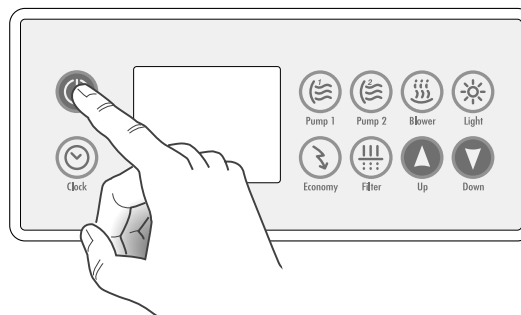

## WINTERING PROCEDURE

### IN TEMPERATE CLIMATES

In areas where the temperature falls below zero only occasionally, the water can be left in the minipool as long as it has “antifreeze protection”.

**CAUTION:** leave the system connected to the electrical power supply so that the “antifreeze protection” can come into operation if the water should drop below 5 °C.

This function operates by activating the heater and the whirlpool pumps in alternation until the water temperature is raised to 7 °C.

### IN COLD CLIMATES

Empty the minipool completely, as follows:

- isolate the minipool from the power supply (1)
- remove the inspection panel (2)
- open the drain valve and the bleed cocks (3)
- unscrew the drain plugs on the pump casings (4)
- using a liquids vacuum cleaner, remove water from the bottom of the pool and from the AIR JET outlets.

Remove and clean the filters, and store in a dry place.

Cover the minipool with the canvas provided, so that it will not collect dirt.

Before using the Teuco Minipool again after the winter break, repeat the steps indicated for **STARTING UP FIRST TIME**.

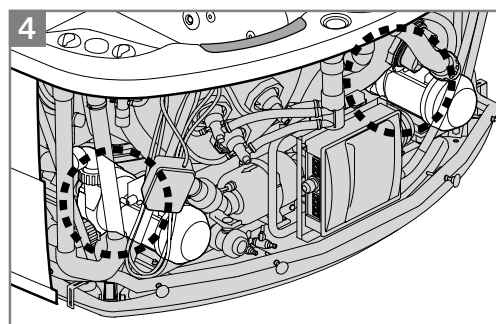
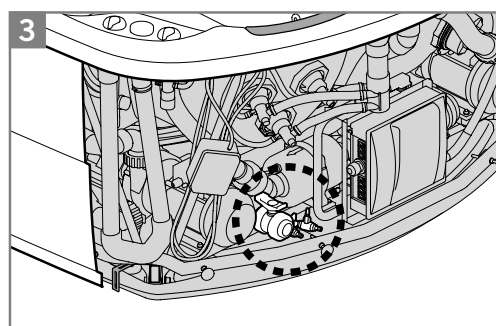
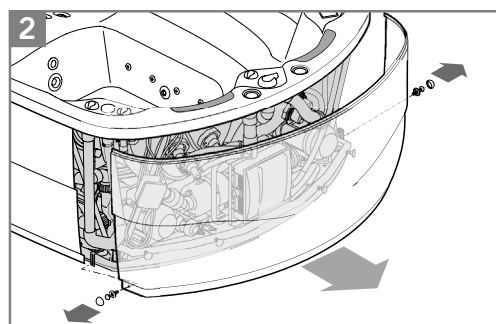
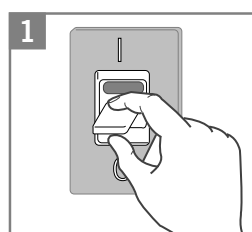
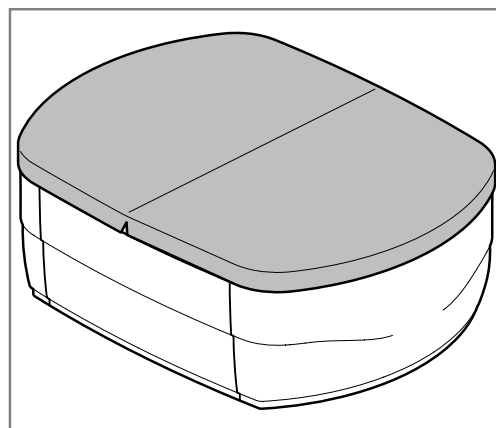

If any part of the appliance fails to operate as it should (e.g. replacing the lamp in the light fixture...), call the nearest Teuco Authorized Service Centre (see list attached).

## DIAGNOSTICS MESSAGES

The appliance is equipped with various safety features which monitor the operation of the system.

In the event of malfunction, the system responds automatically by deactivating the function currently selected and displaying an error message.

TROUBLE OR FAULT	CAUSE	ACTION
<b>CLE</b>  <b>HL Blinking</b> - The temperature of the water in the minipool is higher than 44 °C.  <b>HL permanently alight</b> - The temperature of the water in the heater is higher than 48 °C.	Filters dirty or blocked.  Temperature of water in the minipool too high.  Sudden loss of electrical power with water heater in operation.	Clean the filters .  Set a lower temperature value and wait for the water to cool. <i>If the fault persists, call the nearest Teuco Authorized Service Centre.</i>
<b>FLO</b> - The system is not sensing any flow of water in the recirculation circuit.	Pump valves closed or filter blocked.	Isolate the minipool from the power supply and wait for the water to cool down (about 1 hour). Power the system up again, and <i>if the fault persists, call the nearest Teuco Authorized Service Centre.</i>
<b>Prr</b>	Problem with temperature probe.	Call the nearest Teuco authorized Service Centre.
<b>H2O</b>	Water level too low.	Add water, and if the problem persists, contact a <i>Teuco Authorized Service Centre.</i>

## REMOVING SCUFFS, SCRATCHES AND CIGARETTE BURNS

Firstly, make certain that the scratch or burn has affected only the surface of the acrylic material.

This type of repair must be entrusted to a professional with the necessary skills.

