

# TEAC



## SERVICE MANUAL

# CR-H250

CD Receiver

COMPACT  
disc  
DIGITAL AUDIO

DAB  
Digital Audio Broadcasting

For U.K.

### CONTENTS

1 SPECIFICATIONS .....	2
2 MICROCOMPUTER PIN FUNCTIONS .....	3
3 EXPLODED VIEWS AND PARTS LIST .....	11
4 PC BOARDS AND PARTS LIST .....	13
5 INCLUDED ACCESSORIES .....	17

### NOTES

- PC boards shown are viewed from parts side.
- The parts with no reference number or no parts number in the exploded views are not supplied.
- As regards the resistors and capacitors, refer to the circuit diagrams contained in this manual.
- ⚠ Parts marked with this sign are safety critical components. They must be replaced with identical components - refer to the appropriate parts list and ensure exact replacement.

# 1 SPECIFICATIONS

## AMPLIFIER Section

Output Power ..... 25 W/ch (6 ohms, 0.5 %, 1 kHz)  
Input Sensitivity ..... 300 mV/47k ohms  
Frequency Response ..... 20 Hz to 60,000 Hz (+1/-3 dB)

## TUNER Section

### FM Section

Tuning Range ..... 87.50 MHz to 108.00 MHz (50 kHz steps)  
Signal-to-Noise Ratio ..... 65 dB (Mono)  
60 dB (Stereo)  
Presets ..... 30

### AM Section

Tuning Range ..... 522 kHz to 1629 kHz (9 kHz steps)  
Signal-to-Noise Ratio ..... 35 dB  
Presets ..... 30

### DAB Section

Tuning Range ..... Band 3, 174 MHz-240 MHz  
Input ..... 50 ohms, nominal  
Max Signal ..... -3 dBm typ  
Sensitivity ..... -96 dBm typ  
Adjacent Channel Rejection ..... 35 dB typ  
  
Presets ..... 10  
Audio Output ..... Stereo, 2.5 Vp-p  
Digital Output ..... 24 bit/48 kHz resolution

## CD PLAYER Section

Frequency Response ..... 20 Hz to 20,000 Hz ( $\pm 2$  dB)  
Signal-to-Noise Ratio ..... more than 85 dB  
Wow and Flutter ..... Unmeasurable

## GENERAL

Power Requirements ..... 230 V AC, 50 Hz  
Power Consumption ..... 75 W  
(standby) ..... 2 W  
  
Dimension (W x H x D) ..... 215 x 110 x 359 mm  
Weight ..... 4.4 kg

## Standard Accessories

Remote Control Unit (RC-956) x 1  
Batteries (AAA) x 2  
AM Loop Antenna x 1  
FM Lead-type Antenna x 1  
DAB Antenna x 1  
Owner's Manual x 1  
Warranty Card x 1

- Design and specifications are subject to change without notice.
- Weight and dimensions are approximate.

# 2 MICROCOMPUTER PIN FUNCTIONS

## ST92F124V1

### ■ PIN ASSIGNMENT

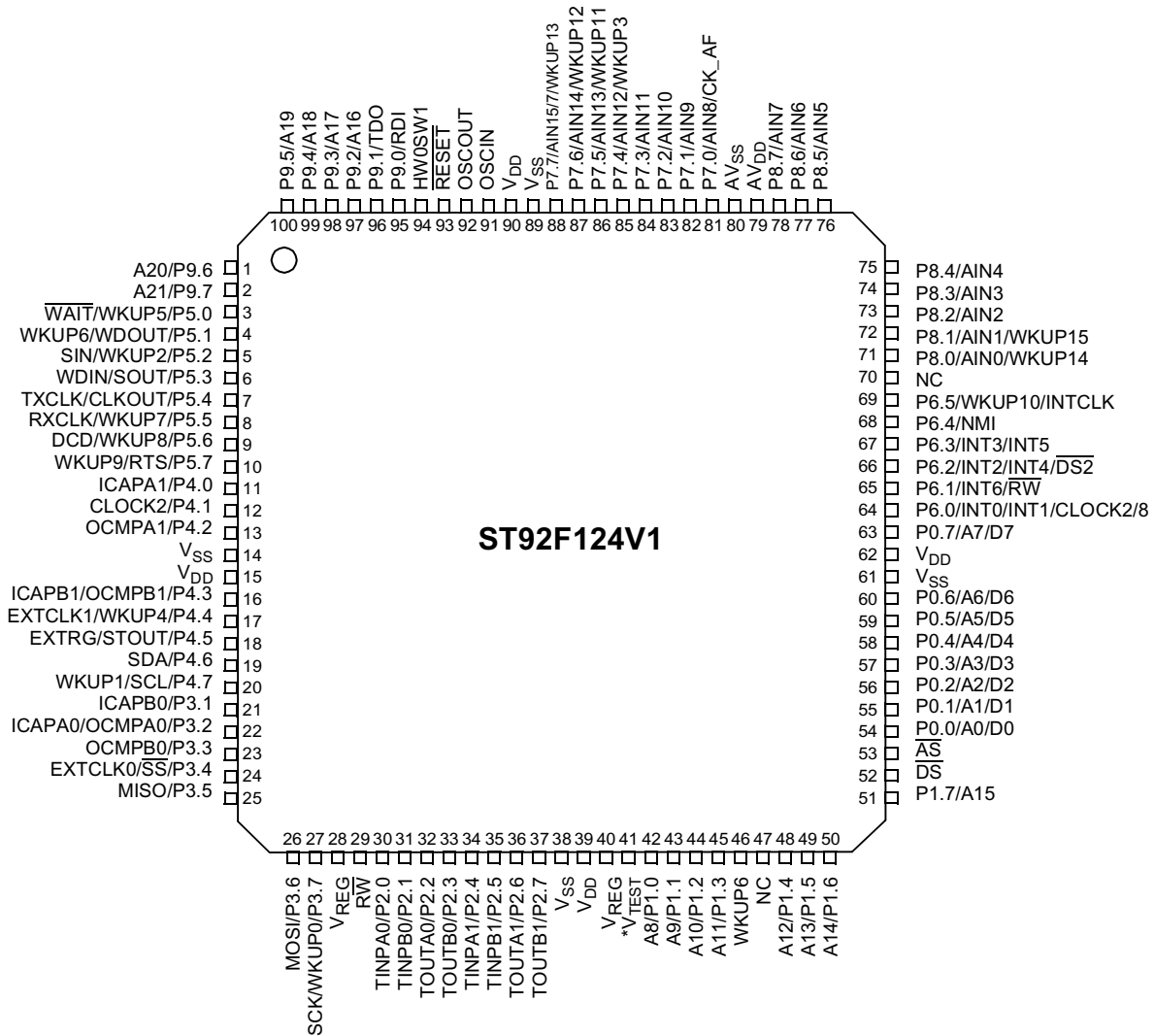

\* V<sub>TEST</sub> must be kept low in standard operating mode.

## ■ BLOCK DIAGRAM

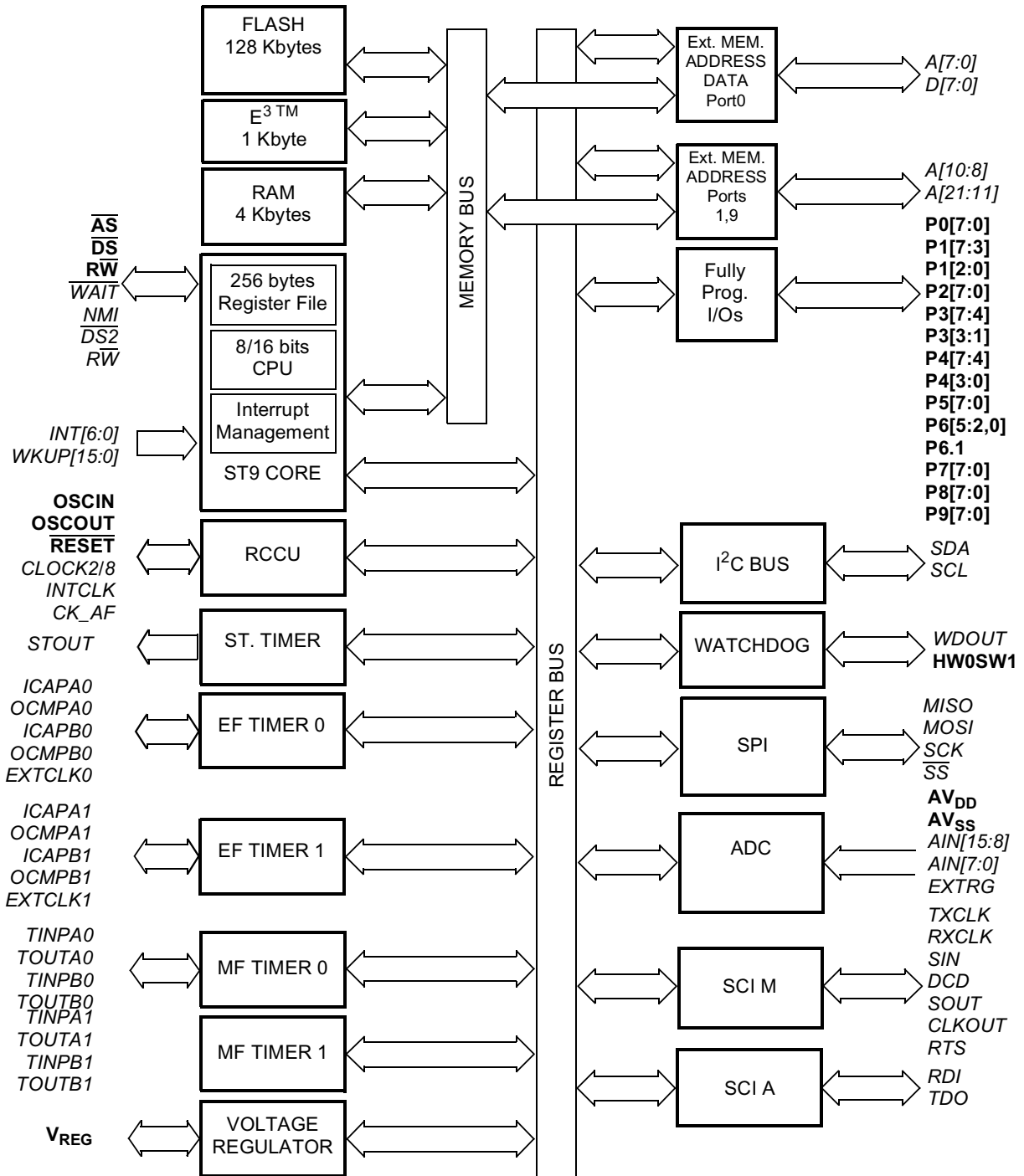

The alternate functions (*Italic characters*) are mapped on Port 0, Port 1, Port2, Port3, Port4, Port5, Port6, Port7, Port8 and Port9.

## ■ PIN FUNCTIONS

PIN No	PIN Name	I/O	Function
1	SM_CE	0	FIP Driver(IC42) Chip enable Port
2	VFD_BLK	0	VFD Control Port
3	DAB_DIN	I	DAB Data Input Port
4	DAB_CLK	0	DAB Data Clock Port
5	DAB_DOUT	0	DAB Data Output Port
6	NC	-	No Connection
7	NC	-	No Connection
8	STANBY	0	Stanby LED On Control Port (Active "H")
9	F_MUTE	0	Function Mute Port (Active "H")
10	NC	-	No Connection
11	OPTION1	-	Option port
12	OPTION2	-	
13	OPTION3	-	
14	GND	-	GND Port
15	VDD1	-	Power Supply Port
16	OPTION4	-	Option port
17	RTC_DATA	I/O	Real Time Clock I.C_Data port
18	RTC_CLK	0	Real Time Clock I.C_Clock port
19	RTC_P	0	Real Time Clock I.C_Square wave out port
20	F_STB	0	Function STB control port
21	NC	-	No Connection
22	NC	-	No Connection
23	NC	-	No Connection
24	NC	-	No Connection
25	NC	-	No Connection
26	NC	-	No Connection
27	NC	-	No Connection
28	V_REG	-	Stabilization capacitor for internal voltage regulator.
29	NC	-	No Connection
30	PROTECT	I	Protect Control port (Active "L")
31	SP_ON	0	Speaker On port
32	HP_IN	I	Headphone input control port
33	V_STB	0	Volume IC(IC91) STB port
34	T_MUTE	0	Tuner Mute port
35	V_CLK	0	Volume IC(IC91) Clock output port
36	V_DATA	0	Volume IC(IC91) Data output port
37	BACK_UP	I	BACKUP mode control port
38	VSS2	-	GND
39	VDD2	-	Power Supply port
40	V_REG2	-	Stabilization capacitor for internal voltage regulator.

PIN No	PIN Name	I/O	Function
41	VTEST	-	GND
42	CD_OPEN_M	0	Open Motor control port
43	CD_RW	0	CD Control Interface
44	CD_CCE	0	CD DSP IC Chip enable port (Active "L")
45	CD_BUCK	0	CD DSP IC Clock port
46	NC	-	No Connection
47	NC	-	No Connection
48	CD_RESET	0	CD Reset output port (Active "L")
49	CD_POWER	0	CD Power control port
50	CD_STBY	0	CD Stanby control port
51	NC	-	No Connection
52	NC	-	No Connection
53	NC	-	No Connection
54	CD_LIMIT_SW	I	CD Limit Switch input port
55	CD_CLOSE_SW	I	CD Close Switch input port
56	CD_OPEN_SW	I	CD Open Switch input port
57	CD_BUS3	I/O	CD_BUS Interface port
58	CD_BUS2	I/O	
59	CD_BUS1	I/O	
60	CD_BUS0	I/O	
61	VSS3	-	GND
62	VDD3	-	Power Supply port
63	CD_CLOSE_M	0	Close Motor control port
64	BUS_IN	I	System remote Input port
65	REMOTE	I	Remote Data input port
66	RDS_CLK	I	RDS Clock port
67	NC	-	No Connection
68	NC	-	No Connection
69	BUS_OUT	0	System remote Output port
70	NC	-	No Connection
71	KEY2	I	KEY Data input port
72	KEY1	I	
73	NC	-	No Connection
74	JOG1	I	JOG Data Input port(Master Volume)
75	JOG2	I	
76	NC	-	No Connection
77	NC	-	No Connection
78	NC	-	No Connection
79	VDD4	-	Power Supply port
80	VSS4	-	GND
81	POWER_H	0	Power on control port (Active "H")

PIN No	PIN Name	I/O	Function
82	P/F_DATA	0	PLL/FUNCTION Data Input port
83	P/F_CLK	0	PLL/FUNCTION Clock Input port
84	PLL_DIN	I	PLL Data input port
85	PLL_CE	0	PLL Chip enable port
86	TUNED_IN	I	Tuner Module Tuned control port
87	STEREO_IN	I	Tuner Module Stereo control port
88	RDS_DATA	I	RDS Data input port
89	VSS5	-	GND
90	VDD5	-	Power Supply port
91	OSCIN	-	4MHz Crystal Connection port
92	OSCOUT	-	
93	RESET	I	Reset Input port
94	HWOSW1	-	Watchdog option port
95	SM_DATA0	0	FIP Data input/output port
96	SM_DATA1	0	
97	SM_DATA2	0	
98	SM_DATA3	0	
99	SM_CLK	0	FIP Driver Clock output port
100	SM_RESET	0	FIP Driver Reset port

# S3F84BB

## PIN ASSIGNMENT

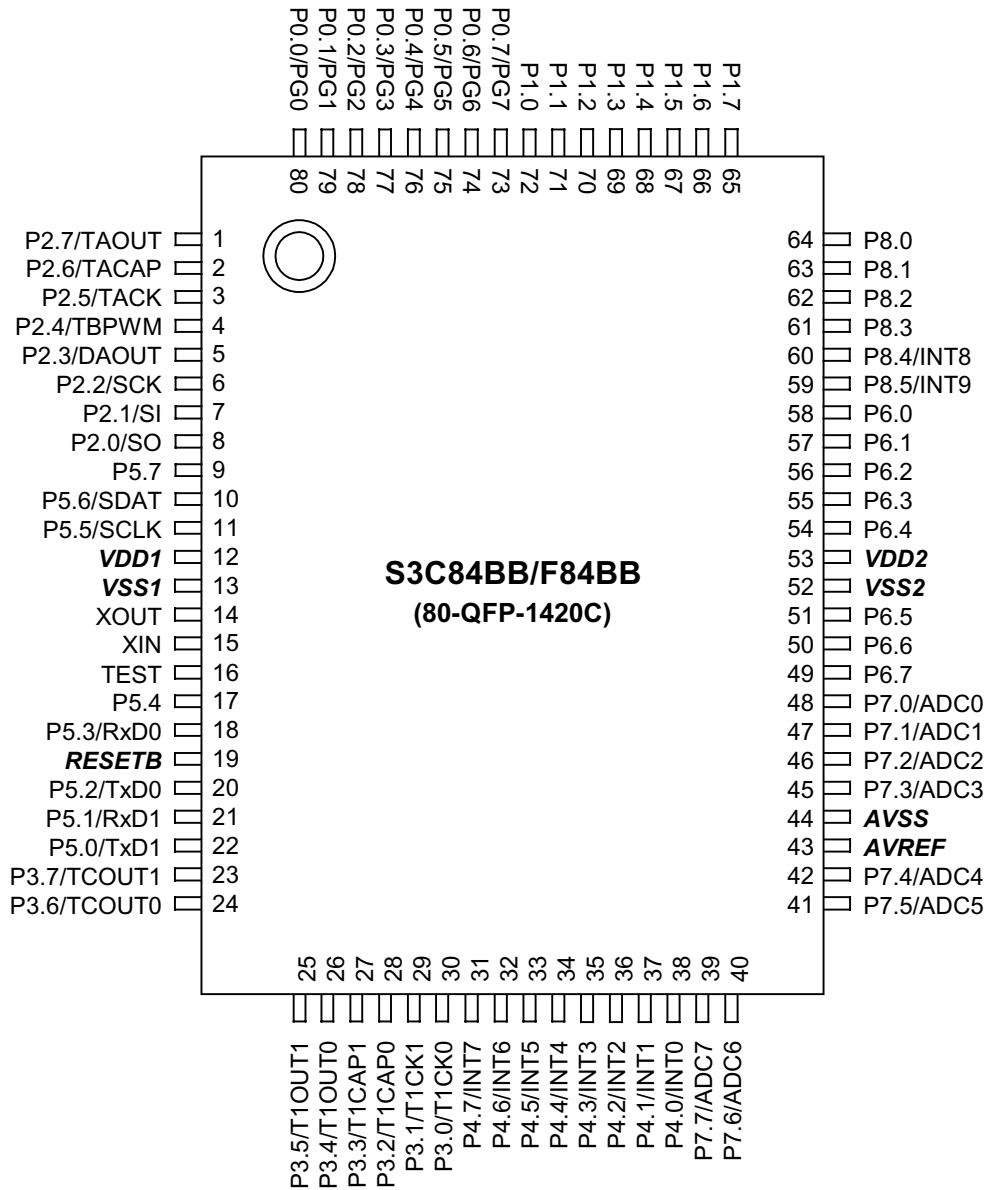



**■ BLOCK DIAGRAM**

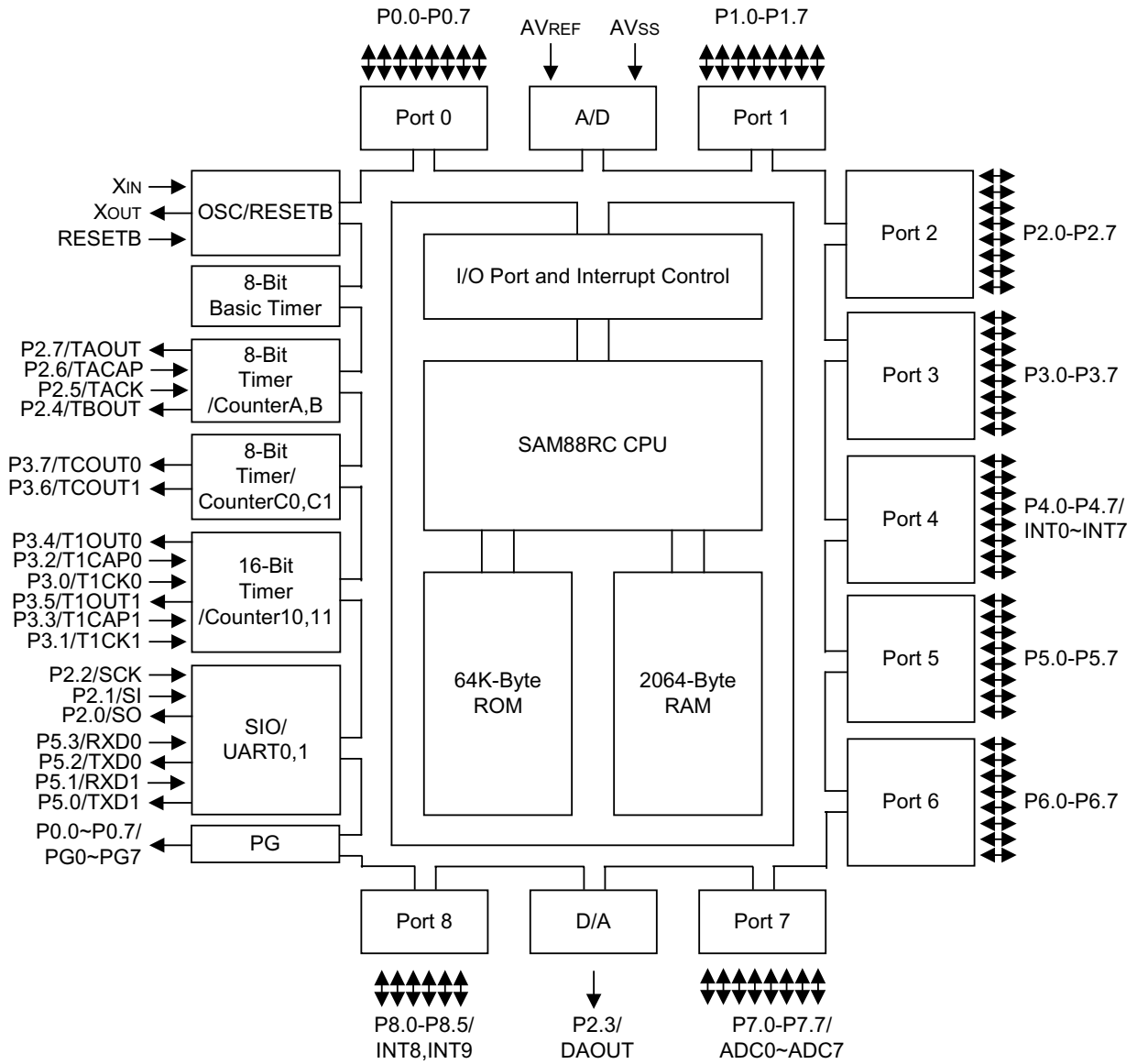

## ■ PIN FUNCTIONS

PIN No.	NAME	I/O	DESCRIPTION
5	VFD_CS	0	VFD STB port
6	VFD_CLK	0	VFD Clock port
8	VFD_DATA	0	VFD data port
10	DATA	I	UPDATE data port
11	CLK	I	UPDATE clock port
12	VDD 1	-	Power input port
13	VSS 1	-	GND
14	X OUT	-	10MHz Crystal Connection port
15	X IN	-	
16	TEST	I	Pull - down register connected internally
19	VFD_RESET	I	VFD Reset port
27	DATA 3	I	FIP data in/out port
28	DATA 2	I	FIP data input port
29	DATA 1	I	
30	DATA 0	I	FIP data output port
31	CS	I	FIP driver IC(IC42) chip enable port
32	CLK	I	FIP driver IC(IC42) clock in/out port
43	AVREF	-	A/D converter reference voltage
44	AVSS	-	A/D converter ground
52	VSS 2	-	Power input port
53	VDD 2	-	GND

### 3 EXPLODED VIEWS AND PARTS LIST

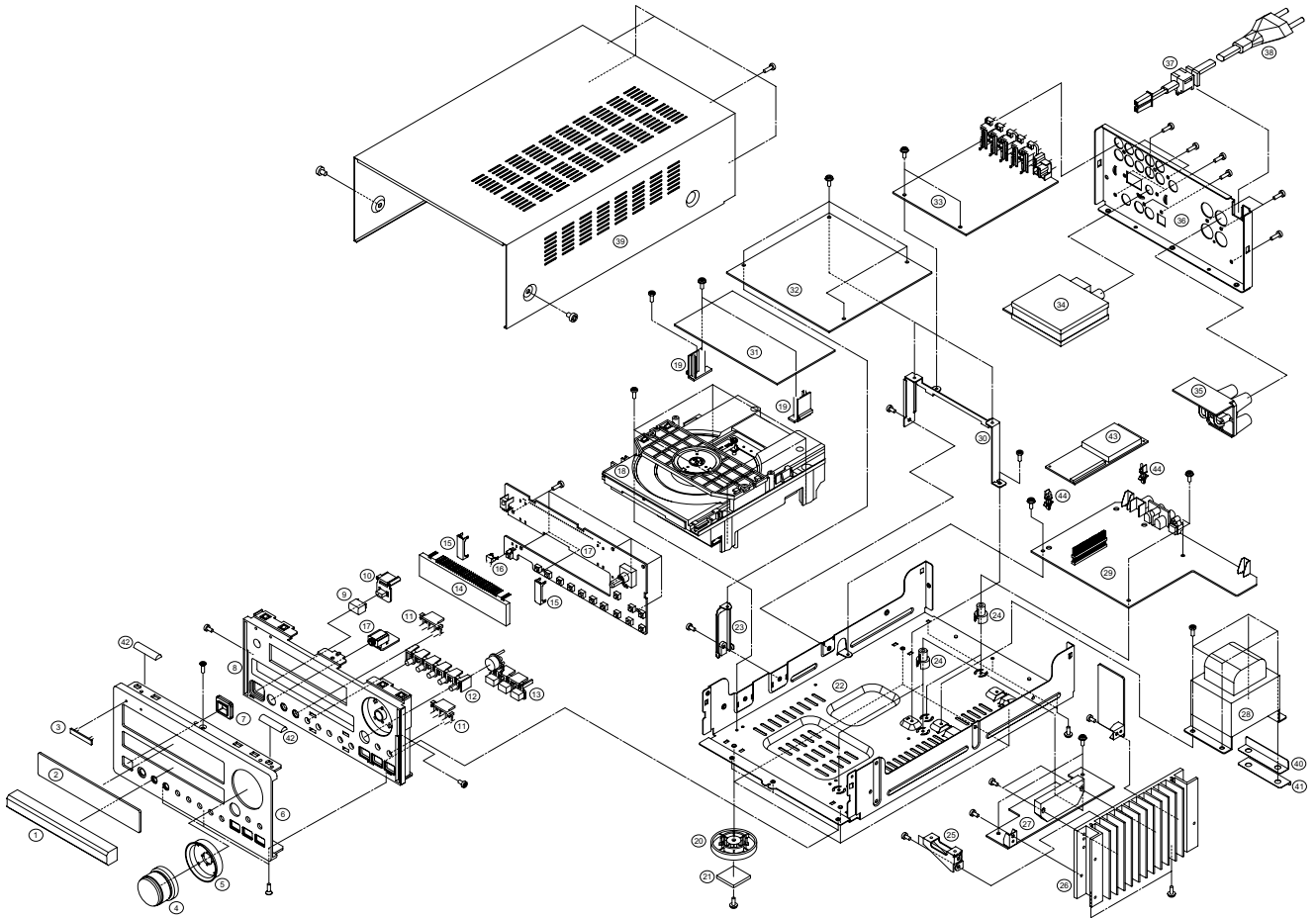

## EXPLODED VIEW LIST

REF. NO.	PARTS NO.	DESCRIPTION	REMARKS
1	CGR1A345M7ZG5	ORNAMENT, DOOR	
2	CGU1A347Z	WINDOW, FIP	
3	KGB1A047Z	BADGE, TEAC	
4	CGK1A098YA	VOLUME KNOB ASSY	
5	CGR1A346MBC22	ORNAMENT, RING	
6	CKM1A144YC35	PANEL, FRONT	
7	CGL1A133	INDICATOR, STAND BY	
8	CGW1A386M7ZG5	PANEL, SUB	
9	CBT1A495M7G5	CAP, STAND BY	
10	CBT1A483	KNOB, STAND BY	
11	CBT1A493MBC22	KNOB, CPS	
12	CBT1A942M7G5	KNOB, MODE	
13	CBT1A943M7ZG5	KNOB, PLAY	
14	HFLHCA-17SM02T	FIP	
15	CMD1A468	BRACKET, FLT	
16	CMD1A376	SUPPORT, LED	
17	COP11721B	PCB, MAIN ASSY	
18	CJDKSL2130CCM	CD SINGLE MECH	
19	KMH1A092	SUPPORT, PCB	
20	CKL2A055H45	FOOT	
21	KHG1A050Y	CUSHION, FOOT	
22	CUA1A248	CHASSIS, BOTTOM	
23	CMD1A395	BRACKET, PCB	
24	CHE1A030	HOLDER, PCB	
25	CMD1A530	BRACKET, PCB(A)	
26	CMY1A233	HEAT SINK	
27	COP11720B	PCB, POWER ASSY	
28	△ CLT5P040ZE	TRANS, POWER	
29	COP11720B	PCB, POWER ASSY	
30	CMD1A531	BRACKET, PCB	
31	COP11767C	PCB, CD ASSY	
32	COP11721B	PCB, MAIN ASSY	
33	COP11721B	PCB, MAIN ASSY	
34	CNVMB114MA18L	TUNER MODULE (EUR)	
35	COP11720B	PCB, POWER ASSY	
36	CKF2A282X	PANEL, REAR	
37	△ KHR1A028	BUSHING, AC CORD	
38	△ CJA2E045ZA	CORD, POWER	
39	CKC1B156S35	CABINET, TOP	
40	CGX1A361	SHEET, HIGH	
41	CGX1A362	SHEET, LOW	
42	KMC1A245	SHIELD CUSHION	
43	HNVS2020VENICE	DAB MODULE, FS2020VENICE1.1	
44	CMH1A226	SUPPORT, PCB	
F751	△ KBA2C2000TLEZ	FUSE	
	CLZ9W003Z	FERRITE RING, 29X7.7X19	
	CLZ9Z028Z	FERRITE CORE, 21.2X6.4X12.7	
	CWC1F1A16A130A	CARD CABLE, 16P	
	CWC1C4A17B070B	CARD CABLE, 17P	
	CWC1B2A17A080B	CARD CABLE, 17P	
	CWC1C4A17B200B	CARD CABLE, 17P	
	CWC1B2A23A070B	CARD CABLE, 23P	
	CWC1B2A23A100B	CARD CABLE, 23P	

## 4 PC BOARDS AND PARTS LIST

MAIN PCB

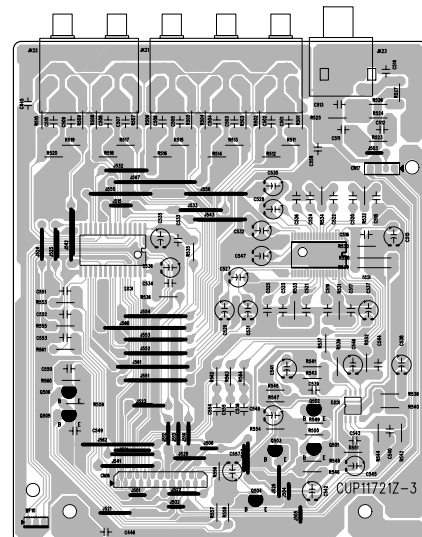
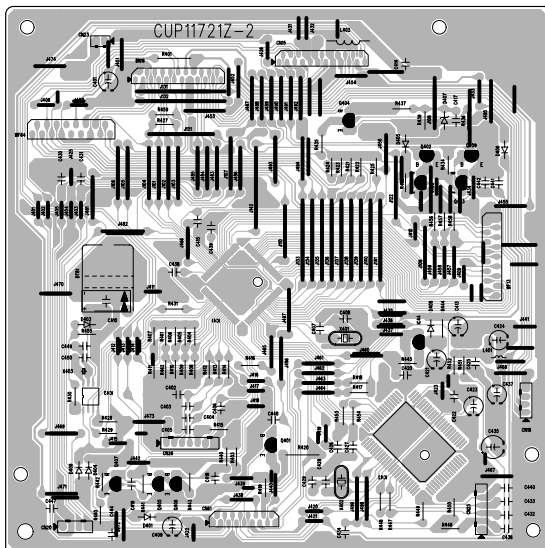
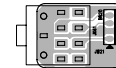
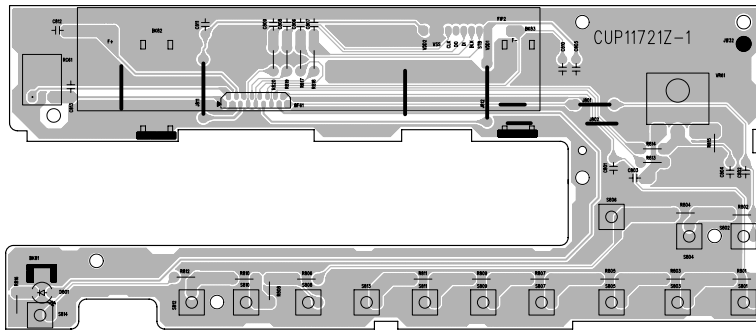

POWER PCB

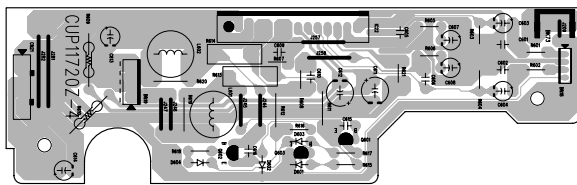
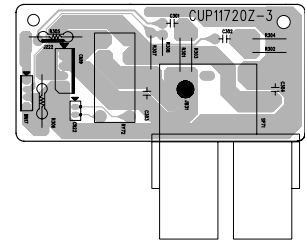
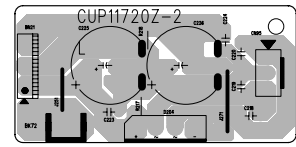
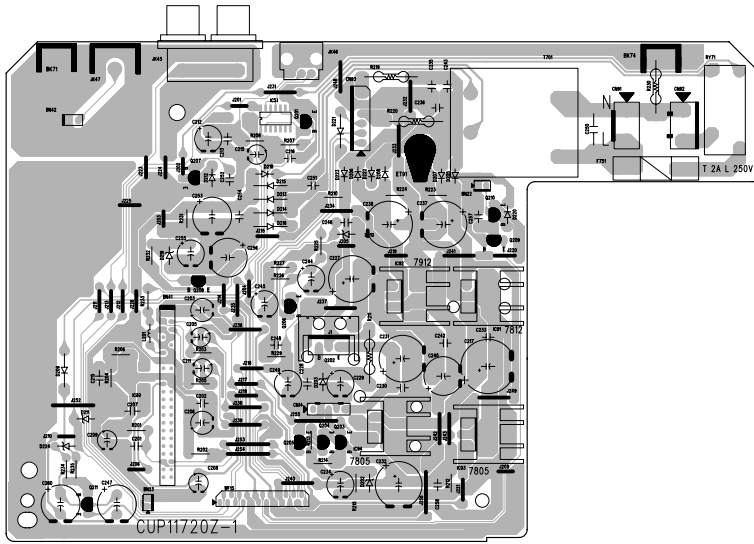

**CD PCB ASSY**

REF. NO.	PARTS NO.	DESCRIPTION
	COP11767C	PCB, CD ASSY
	CUP11767Z	PCB, CD
CN10	KJP05GA19ZM	WAFER, MOLEX53014-0510
CN11	KJP06GA19ZM	WAFER, MOLEX53014-0610
CN12	KJP16GB113ZG	WAFER, 16P
CN13	KJP17GB116ZG	WAFER, GF120-17S-LS
D102	HVD1SS133MT	DIODE, 1SS133T-77
IC10	HV1TC9462F	IC, TC9462F
IC12	HV1TA2153FN	IC, TA2153FN
IC13	HV1TA2125AF	IC, TA2125AF
IC15	△ HV1KA78L05AZT	IC, KA78L05AZT
L100	HLQ02C100KT	COIL, AXAIL
Q100	HVTKTA1266YT	TR, KTA1266Y
X101	HOX16934E120C	CRYSTAL, 16.934MHZ

**MAIN PCB ASSY (GATHER)**

REF. NO.	PARTS NO.	DESCRIPTION
	COP11721B	PCB, MAIN ASSY
	CUP11721Y	PCB, MAIN
BK81	CMD1A376	SUPPORT, LED
BK82	CMD1A468	BRACKET, FLT
BK83	CMD1A468	BRACKET, FLT
BN16	KJP23GA117ZG	WAFER, GF102-23S-TS
C410	BCE50HD104	C, GOLD EECS0HD104V
CN15	KJP23GA117ZG	WAFER, GF102-23S-TS
CN16	KJP23GA117ZG	WAFER, GF102-23S-TS
CN17	CJP04GA19ZY	WAFER, 4P 00906-0027
CN18	CJP04GA19ZY	WAFER, 4P 00906-0027
CN20	CJP04GA19ZY	WAFER, 4P 00906-0027
CN23	CJP02GA19ZY	WAFER, 2P
CN25	CJP06GA19ZY	WAFER, 6P
CN26	CJP07GA19ZY	WAFER, 7P
CN61	KJP17GA117ZG	WAFER, GF102-17S-TS
D401	HVD1SS133MT	DIODE, 1SS133T-77
D403	HVD1SS133MT	DIODE, 1SS133T-77
D404	HVD1SS133MT	DIODE, 1SS133T-77
D405	HVD1SS133MT	DIODE, 1SS133T-77
D406	HVD1SS133MT	DIODE, 1SS133T-77
D407	HVDMTZJ4.3CT	DIODE, ZENER MTZJ4.3C
D408	HVD1SS133MT	DIODE, 1SS133T-77
D409	HVD1SS133MT	DIODE, 1SS133T-77
D801	HVD342YCTB7T089	LED, YELLOW SLR342YCTB7
FIP2	HFLHCA-17SM02T	FIP
IC41	HV1ST92F124V1T6	IC, ST92F124V1T6
IC42	HV1S3F84BB	IC, S3F84BB
IC43	HV1DS1307Z	IC, DS1307Z
IC44	HV1RE5VL28CATZ	IC, RE5VL28CATZ

**MAIN PCB ASSY (GATHER)**

REF. NO.	PARTS NO.	DESCRIPTION
IC51	HV1LC75343M	IC, LC75343M
IC52	HV1TC9163AF	IC, TC9163AF
IC53	HVINJM2068MDTE1	IC, NJM2068MD-TE1
JK21	CJJ4M046Z	JACK, BOARD
JK22	CJJ4P014W	JACK, IN/OUT
JK23	CJJ4R019W	TERMINAL, IN/OUT
JK61	HJJ2E027Z	JACK, HEADPHONE
L401	HLQ02C220KT	COIL, 22UH K
L402	KLZ9H001Z	BEAD, CORE
Q401	HVTKRC107MT	TR, KRC107M
Q402	HVTKRA107MT	TR, KRA107M
Q403	HVTKRA107MT	TR, KRA107M
Q404	HVTKSB811YT	TR, KSB811Y
Q405	HVTKRC107MT	TR, KRC107M
Q406	HVTKRC107MT	TR, KRC107M
Q407	HVTKRC107MT	TR, KRC107M
Q408	HVTKRC107MT	TR, KRC107M
Q409	HVTKRC107MT	TR, KRC107M
Q501	HVTKTD1302T	TR, KTD1302
Q502	HVTKTD1302T	TR, KTD1302
Q503	HVTKRA107MT	TR, KRA107M
Q504	HVTKRA107MT	TR, KRA107M
Q505	HVTKTD1302T	TR, KTD1302
Q506	HVTKTD1302T	TR, KTD1302
RC61	KRVH1M602H32	SENSOR, REMOCON
S801	CST1A012ZT	SW, TACT 00802-0005
S802	CST1A012ZT	SW, TACT 00802-0005
S803	CST1A012ZT	SW, TACT 00802-0005
S804	CST1A012ZT	SW, TACT 00802-0005
S805	CST1A012ZT	SW, TACT 00802-0005
S806	CST1A012ZT	SW, TACT 00802-0005
S807	CST1A012ZT	SW, TACT 00802-0005
S808	CST1A012ZT	SW, TACT 00802-0005
S809	CST1A012ZT	SW, TACT 00802-0005
S810	CST1A012ZT	SW, TACT 00802-0005
S811	CST1A012ZT	SW, TACT 00802-0005
S812	CST1A012ZT	SW, TACT 00802-0005
S813	CST1A012ZT	SW, TACT 00802-0005
S814	CST1A012ZT	SW, TACT 00802-0005
VR61	HSR2A011Z	VR, ENCODER EC16B243040F
WF10	CJP03GA19ZY	WAFER, 3P
WF13	KJP17GA115ZG	WAFER, GF120-17S-TS
WF61	KJP17GB113ZG	WAFER
WF64	KJP17GA115ZG	WAFER, GF120-17S-TS
X401	HOX04000E150C	CRYSTAL, 4MHZ
X402	HOX10000E220TF	CRYSTAL
X403	HOX00032K120I	CRYSTAL, 32.768KHZ

### POWER PCB ASSY (GATHER)

REF. NO.	PARTS NO.	DESCRIPTION
	COP11720B	PCB, POWER ASSY
	CUP11720Y	PCB, POWER
	CMC1A253	PLATE, EARTH
	CMH1A226	SUPPORT, PCB
	HNVFS2020VENICE	DAB MODULE, FS2020VENICE1.1
BK71	CMD1A387	BRACKET, PCB
BK72	CMD1A387	BRACKET, PCB
BK73	CMD1A387	BRACKET, PCB
BK74	CMD1A387	BRACKET, PCB
BN21	KJP06HB60ZY	HOUSING, BMH250
BN41	CJP44TT153ZY	PIN HEADER, DAB2025
BN42	KJP02TT155ZY	PIN HEADER
C225	△ HCEA1VH332E	C, ELECT 3300UF 35V
C226	△ HCEA1VH332E	C, ELECT 3300UF 35V
C227	△ HCEA1EH222E	C, ELECT 2200UF 25V
C237	△ CCEA1EH222E	C, ELECT 2200UF 25V
C238	△ CCEA1EH222E	C, ELECT 2200UF 25V
C247	△ CCEA1CH221T	C, ELECT 220UF 16V
C250	△ KCKDKS472ME	C, CERAMIC 0.0047UF 2.5KV
C253	△ HCEA1EH471T	C, ELECT 470UF 25V
C260	△ CCEA1CH221T	C, ELECT 220UF 16V
CN14	CJP05GA19ZY	WAFER, 5P
CN19	CJP04GA01ZY	WAFER, 4P
CN21	KJP06GA63ZY	WAFER, BMW250
CN22	CJP02GA19ZY	WAFER, 2P
CN91	KJP02KA060ZY	WAFER
CN92	KJP02GA89ZM	WAFER, MOLEX35328-02
CN93	CJP06GA01ZY	WAFER, 6P
CN95	KJP03GA90ZM	WAFER, MOLEX35313-0310
D202	HVDMTZJ6.2BT	DIODE, ZENER MTZJ6.2B
D203	HVDMTZJ9.1BT	DIODE, ZENER MTZJ9.1B
D204	△ BVDPBU604F	DIODE, BRIDGE PBU604F
D205	△ KVD1N4003SRT	DIODE, 1N4003
D206	△ KVD1N4003SRT	DIODE, 1N4003
D207	△ KVD1N4003SRT	DIODE, 1N4003
D208	△ KVD1N4003SRT	DIODE, 1N4003
D209	△ KVD1N4003ST	DIODE, 1N4003
D210	HVDMTZJ33BT	DIODE, ZENER MTZJ33B
D211	HVDMTZJ2.7BT	DIODE, ZENER MTZJ2.7B
D212	HVD1SS133MT	DIODE, 1SS133T-77
D213	△ KVD1N4003ST	DIODE, 1N4003
D214	△ KVD1N4003ST	DIODE, 1N4003
D215	△ KVD1N4003ST	DIODE, 1N4003
D216	△ KVD1N4003ST	DIODE, 1N4003
D218	HVD1SS133MT	DIODE, 1SS133T-77
D219	HVDMTZJ6.8BT	DIODE, ZENER MTZJ6.8B
D220	KVD1N4003SRT	DIODE, 1N4003
D221	△ KVD1N4003ST	DIODE, 1N4003
D222	△ KVD1N4003SRT	DIODE, 1N4003
D223	△ KVD1N4003SRT	DIODE, 1N4003
D224	HVDMTZJ4.3CT	DIODE, ZENER MTZJ4.3C
D601	HVD1SS133MT	DIODE, 1SS133T-77
D602	HVD1SS133MT	DIODE, 1SS133T-77
D603	HVD1SS133MT	DIODE, 1SS133T-77
D604	HVD1SS133MT	DIODE, 1SS133T-77

### POWER PCB ASSY (GATHER)

REF. NO.	PARTS NO.	DESCRIPTION
ET91	CNE75	PLATE, EARTH
F751	KJCFCS5	HOLDER, FUSE
IC21	BV174HC4066D	IC, 74HC4066D
IC22	BV1STK442-050	IC, STK442-050
IC91	CMY1A043	HEAT SINK
IC91	△ HVINJM7812FA	IC, NJM7812FA
IC92	CMY1A025	HEAT SINK
IC92	△ HVINJM7912FA	IC, NJM7912FA
IC93	CMY1A043	HEAT SINK
IC93	△ HVINJM7805FA	IC, NJM7805FA
IC94	CMY1A025	HEAT SINK
IC94	△ HVINJM7805FA	IC, NJM7805FA
IC95	△ HVIRC1117ST	IC, RC1117ST
JK45	CJJ4N064Z	JACK, BOARD
JK46	HJSTOTX179L	MODULE, OPTICAL TOTX179L
JK47	CJJ3G012Z	ANT, TERMINAL RF-055A
L201	HL002C2R7KT	COIL, 2.7UH K
L601	CLEYOR5KAK	COIL, SPEAKER 0.5UH K
L602	CLEYOR5KAK	COIL, SPEAKER 0.5UH K
Q201	HVTKRC107MT	TR, KRC107M
Q202	CMY2A048	HEAT SINK
Q202	△ HVTKTC2026Y	TR, KTC2026Y
Q203	△ HVTKTC2026Y	TR, KTC2026Y
Q204	HVTKRA107MT	TR, KRA107M
Q205	HVTKRC107MT	TR, KRC107M
Q206	△ HVTKSC2316YT	TR, KSC2316Y
Q207	HVTKRC107MT	TR, KRC107M
Q208	△ HVTKSC2316YT	TR, KSC2316Y
Q209	HVTKRA107MT	TR, KRA107M
Q210	HVTKRC107MT	TR, KRC107M
Q211	△ HVTKSC2316YT	TR, KSC2316Y
Q601	KVTKSA1175YT	TR, KSA1175Y
Q602	KVTKSA1175YT	TR, KSA1175Y
Q603	HVTKRC107MT	TR, KRC107M
R211	△ CRG1ANJ331H	R, METAL 330 OHM 1W J
R219	△ KRQ1AJR47H	R, FUSE 0.47 OHM 1W J
R220	△ KRQ1AJR47H	R, FUSE 0.47 OHM 1W J
R305	△ CRG1ANJ391H	R, METAL 390 OHM 1W J
R306	△ CRG1ANJ391H	R, METAL 390 OHM 1W J
R609	△ CRG1ANJ101H	R, METAL 100 OHM 1W J
R610	△ CRG1ANJ101H	R, METAL 100 OHM 1W J
R613	△ CRF5EKR22H	R, CEMENT 0.22 OHM 5W K
R614	△ CRF5EKR22H	R, CEMENT 0.22 OHM 5W K
RY71	△ HSL1A008ZE	RELAY, SDT-S-112DMR
RY72	HSL4A004ZU	RELAY, OSA-SS-212DM3
SP71	CJJ5P012Z	TERMINAL, SPEAKER
T701	△ CLT51003ZE	TRANS, SUB
WF15	KJP23GA117ZG	WAFER, GF102-23S-TS



## 5 INCLUDED ACCESSORIES

### INCLUDED ACCESSORIES

REF. NO.	PARTS NO.	DESCRIPTION	REMARKS
	CQX1A941Z	OWNER'S MANUAL	
	CARTCRH250	REMOCON TRANSMITTER ASSY	
	HABAAAM1.5V	BATTERY	
	CSA1A018Z	FM 1 POLE ANT	
	CSA1A020Z	AM LOOP ANT	
	CSA272	ANT, DAB T	