



SUPER HOT TOASTER

**USERS (Pages 2-3)/ INSTALLATION (Pages 4-7)
AND SERVICING INSTRUCTIONS**

**THIS CAT I_{2H} APPLIANCE IS FOR USE
ON NATURAL GAS G20 AT A SUPPLY
PRESSURE OF 20mbar IN GB and IE**

HAND THESE INSTRUCTIONS TO THE USER

DESCRIPTION

The Super Hot Toaster has a single aerated burner, the design of which produces two parallel ribbons of flame which run across the front of the fire bed. The rear ribbon of flame is ignited first and the front ribbon cross-lights from it instantaneously. A single gas control selects ignition (pilot only) and can be turned anticlockwise to select a high rate and then a reduced input at the maximum rotation. For extra safety the control is designed so that gas cannot be allowed to reach the burner until pilot ignition has been proven. A separate push button piezo igniter provides pilot ignition.

A Flame Supervision Device (FSD) is fitted. This ensures that if the pilot goes out for any reason (including being turned off), the gas flow to the burner is cut off until the full lighting procedure is repeated. The oxy-pilot or O.D.S. will cause the appliance to 'shut off' in the event of continued spillage occurring under hazardous or blocked flue conditions. The burner assembly is fixed to the base of the radiant box which also includes a fire back made of ceramic fibre, this forms an insulating surface to reflect heat into the fire bed, raising its temperature and increasing the amount of heat radiated into the room. A decorative brass trim completes the front face of the appliance.

There are two types of front and fret available for this appliance; these have perforated frets to allow air to be entrained into the fire bed to ensure clean combustion. The optional fire fronts and frets are listed in figure 11. If other Fronts and Frets are to be used they must have a minimum open area in the fret of 20 square centimetres and 60 square centimetres in the Front, as shown in figure 11.

A flame adjustment lever is fitted to allow a longer softer flame to be used to enhance the appearance of the firebed; this can be operated in either the high or low position via the control lever on the front fascia panel.

IMPORTANT NOTES

The Super Hot Toaster is a decorative fuel effect appliance designed and manufactured to the requirements of the British Standards Institution BS 5258 Part 12: 1990 and is for use on Natural Gas only .

All gas appliance installations must be installed by a competent person in accordance with the current Gas Safety (Installation and Use) Regulations 1994 (as amended) or the rules in force and in accordance with the attached Installation Instructions, failure to do so could lead to prosecution.

Areas of this appliance will become hot after prolonged running and it is recommended that for the protection of the very young, elderly and infirm a fireguard conforming to BS 6539 or BS 6778 be used.

Care should be taken to prevent any damage being caused to surrounding soft furnishings or decor e.g. many embossed vinyl wall coverings may become discoloured if located too close to the appliance. Clearances required for combustible shelves are shown on page 3.

It is recommended that the chimney or flue should be swept annually by a competent person and the appliance checked for spillage (smoke test) and that there are no excessive deposits of soot.

The curing effect of heating the coals will cause an initial odour which, although not harmful, may require additional ventilation until the odour has disappeared. This appliance will run on Full for approximately 4.4 hours on one therm of gas.

This product uses fuel effect pieces, gaskets and insulation material containing Refractory Ceramic Fibre (RCF), which are man-made vitreous silicate fibres. **Excessive** exposure to these materials may cause temporary irritation to eyes, skin and respiratory tract, consequently, it makes sense to take care when handling these articles to ensure that the release of dust is kept to a minimum.

TO LIGHT THE APPLIANCE

1. Remove the fret (controls cover), to gain access to the controls
2. Press and turn the gas control until the indicator mark is opposite to IGN. Keep the control fully depressed. Press and release the ignition button. Check that the pilot flame has lit at all ports. Keep the gas control depressed for a further 20 seconds. Release the gas control and check the pilot remains alight.
3. Depress the gas control slightly and turn fully anticlockwise until the indicator mark is opposite the small flame symbol. The burner will now ignite from the pilot assembly and run at the low rate.

4. Depress the gas control slightly and turn clockwise until the indicator mark is opposite to the large flame symbol. The burner will now run at its maximum rate.
5. To turn the appliance 'off', return the control to the 'off' position.
6. If for any reason the fire cuts out, return the control knob to the 'off' position and wait **3 minutes** before re-lighting.

REMOVAL OF DEBRIS or SOOT DEPOSIT

Allow the appliance to cool for two to three hours before removing all of the coals and ceramic blocks for cleaning purposes. Once all the ceramics are removed from the fire bed check that no debris is located in the burner slots (both front & rear). If any debris is present it may easily be removed by using a small piece of thin cardboard to ease out any foreign matter. Be sure to remove the cardboard after use. Cleaning should be carried out in a well-ventilated area or in the open air, by gently brushing with the pieces held away from your face so that you avoid inhaling the dust. We do not recommend the use of a normal domestic vacuum cleaner, which may blow dust back into the air.

SETTING UP THE COAL BED. (See the identification sheet figure 13)

Components

2 burner inserts.	12 Large Coals.
Coal support shelves (L&R hand).	5 Medium Coals.
Artificial coal front.	2 Triangular Coals

Place the left and right coal support shelves with the rebate on the underside, over the rear flange of the support channel. Place the two shaped burner inserts into the channel between the front and rear ports of burner. Locate the fibre artificial coal front on the shelf above the fascia panel. Figure 7.

COAL LAYOUT

First Layer. Position 4 large coals with their rear edge on the burner inserts. Place 3 large coals at the rear of the coal support shelf and lay 2 further at the sides of the shelf. These coals are placed on their edge. 3 more large coals are placed on the coal support shelf to complete the first layer. See figure 8.

Second Layer. Two triangular coals are placed one either side ensuring that they rest against the side and straddle the gap between the front and second row large coal. Position the remaining 5 medium coals in the positions shown in figure 9.

To obtain the best visual appearance it may be necessary to make slight adjustments to the position of the coals.

NOTE: **Additional coals must not be used.** If any of the coals or the coal bed becomes damaged, lost or broken, replacements must be obtained before the appliance is used.

VENTILATION

Purpose built ventilation is not required for this appliance in GB only. For Ireland (IE) ventilation is required with a minimal cross sectional area of 100 sq. cms and should be checked regularly to ensure that it is free from obstruction. It must be fitted in accordance with the rules in force.

CLEARANCE TO SHELVES

Minimum clearances to underside of a 150mm (6ins) combustible shelf from the top of the fire opening must be 228mm (9ins). Add 12.5mm (1/2in) to this clearance for every 25mm (1in) increased depth of shelf.

CLEARANCE TO SIDES

Minimum Clearance required to any combustible material to the side of the appliance must be 150mm (6in)

INSTALLATION REQUIREMENTS AND REGULATIONS

The appliance must be installed by a competent person in accordance with the current Gas Safety (Installation and Use) Regulations 1994 (as amended) or the rules in force and in accordance with the manufacturers instructions, failure to do so could lead to prosecution.

The following are the relevant Codes of Practice and British Standards.

The Building Regulations issued by the Department of the Environment.

The Building Standards (Scotland)(Consolidation) Regulations issued by the Scottish Development Department.

BS 8303 1986	BS 5440 Pt1 1990 & Pt2 1989	BS 7566 Pts 1-4 1992
BS 1251 1987	BS 5871 Pt3 1991	
BS 6891 1988	BS 6461 Pt1 1984	

Important Notes

The fire place, chimney or flue must be sound and conform to the requirements of BS 8303 1986 & BS 6461 Part 1 1984.

The effective flue height must be a minimum of 3 metres and should be a 225mm x 225mm brick, stone or a lined flue with a minimum diameter of 175mm. Any permanent flue restrictions must be removed, and any variable dampers locked fully open or removed. The flue must be swept prior to installation, unless new.

Care should be taken to prevent any damage being caused to surrounding soft furnishings or decor e.g. many embossed vinyl wall coverings may become discoloured if located too close to the appliance. Clearances required for combustible shelves are shown on page 4.

A hearth must always be provided to project forwards of the brass trim a minimum of 300mm and a minimum of 150mm either side of the fire opening. The hearth must be a minimum thickness of 12mm with a perimeter height of 50mm to deter combustible materials, carpets etc, being placed on the hearth. The area under the firebox must have a minimum non-combustible thickness of 25mm. In most installations a back panel will be required, this will need a minimum fire resistance rating of Class O (100⁰C).

TECHNICAL DATA

Height	560mm overall size of Box
Width	410mm overall size of Box
Depth	265mm overall size of Box
Height of Trim	605mm
Width of Trim	505mm
Overall Depth inc. Front & Fret using (MACH 11)	340m
" " " " " " " (JB)	360mm
Maximum heat input (HIGH) (GROSS)	6.95 kW, 23,700 Btu/h
Minimum heat input (LOW) (GROSS)	3.83 kW, 13,000 Btu/h
Supply pressure (cold)	20 mbar +/- 1 mbar
Injector marking	Bray Cat. 82/510
Pilot	OP Oxy/Pilot NG 9022
Gas Connection	8mm O/D Tube

CONTENTS CHECK LIST (See figure 13 for identification)

VENT BOX ASSEMBLY C/W: Burner assembly and Brass trim.

- 1 Simulated coal front
- L & R Hand coal support shelves
- 2 Burner inserts
- 12 Large, 5 Medium and 2 Triangular Coals.
- Fitting kit
- Installation & Users Instructions.

INSTALLING THE APPLIANCE

If a fire back (chair brick) is fitted in the existing builders opening it will be necessary to remove it together with any infill or rubble. Any remedial work should be carried out including levelling the base beneath the fire. The sizes required for the opening are shown in Fig 2.

DISMANTLING THE FIRE PRIOR TO INSTALLING

To prevent any damage and to assist with the installation of the appliance both the burner and the trim should be removed. The trim is removed by lifting the trim vertically observing that the lugs locate over the flanges of the box. To remove the burner from the box unscrew the two screws at the base of the fascia panel and pull the burner forward observing that the rear feet locate under two lugs in the base panel.

GAS SUPPLY

BEFORE COMMENCING WORK, TURN OFF ANY APPLIANCES THAT ARE FED BY THE METER AND ISOLATE THE SUPPLY BY TURNING OFF AT THE METER.

The gas connection to this appliance is made with 8mm O/D rigid or semi rigid tube to a pressure test elbow situated on the left-hand side of the burner as shown in Fig 1. It is advisable to provide a means of isolating the gas supply to the appliance for servicing with either a restrictor elbow or isolation cock as shown in Fig 1. A 45mm length of Bundy is supplied for use with a restrictor elbow or a 90 degree bend for use with an isolation cock; (the supply tube support bracket may be removed as shown in Fig 4. Provision is made in the rear of the box to make a concealed connection; (additional holes may be drilled as required). The installer is reminded of the requirements of BS 6891 1988 dealing with enclosed pipes. The standard requires that when a gas pipe is fed through a wall, the pipe should be enclosed in a tight sleeve to protect against failure caused by movement and shall be constructed to prevent a passage of gas either between the pipe and sleeve or sleeve and the wall. If a gas supply is required to be fed from either the left or right across the front of the appliance it should be routed as shown in Fig 7. It is only the MACH II Cast Iron Front & Fret that has provision for this requirement alternative Fronts & Frets will need modifying to allow access for the supply tube, see Fig 5. If a JB front and fret is being used it will require two stops to be fitted using the self-tap screws and spacers shown in Fig 7.

FITTING THE VENT BOX.

Position the box in the centre of the opening with a sufficient gap between the front flanges and the surround to enable the tags on the rear of the brass trim to slide over. (Where a concealed gas supply is used feed the supply to the position of the burner connection). The box is secured in place with the two 10x1 1/4 round headed screws and plastic plugs supplied in the fitting kit using the two holes in the base of box. Replace the burner assembly in position ensuring that the rear legs locate under the tags in the base plate and secure with the two screws provided. Complete the gas connection to the burner as required and fit the brass trim by locating the tags in the cut outs in the side flanges and sliding the trim down until the top tag locates over the top flange, remove the protective plastic coating before lighting fire.

TO CHECK THE APPLIANCE SETTING PRESSURE & LEAK TEST

A Pressure Test Point at the inlet elbow enables verification of the inlet pressure of the appliance under operating conditions and can also be used to check the gas soundness of the connections to the appliance gas control. To check the joints of the burner assembly for gas soundness it will be necessary to carry out the examination prior to installing into the case. If a manometer is used care must be taken to ensure that it is not disconnected with the gas turned on and the fuel bed hot.

TO VERIFY THE INLET PRESSURE

The inlet pressure should be observed at 20mbar +/- 1mbar when the appliance is operating at its maximum rate. Any significant reduction below an inlet pressure of 20mbar will indicate a restriction in the gas supply to the appliance that should be identified and corrected. If there are any other appliances that are relatively high rated (e.g. a central heating boiler) fed from the same gas supply branch, it is advisable to perform this observation with both appliances in operation.

LOCATION OF THE FIBRE BED (See figure 13 for identification of components)

Position the two burner inserts between the front and rear ports of the burner, and place the simulated coal front in position as shown in figure 7. The L&R Hand coal support shelves are positioned so that the rebated channel on the under side locate over the rear flange of the fibre support channel. Two stops prevent the shelf closing the gap between the back of the burner inserts and the front edge of the shelf; there should be a minimum gap of 6mm.

COAL LAYOUT

First Layer. Position 4 large coals with their rear edge on the burner inserts. Place 3 large coals at the rear of the coal support shelf and lay 2 further at the sides of the shelf. These coals are placed on their edge. 3 more large coals are placed on the coal support shelf to complete the first layer. See figure 8.

Second Layer. Two triangular coals are placed one either side ensuring that they rest against the side and straddle the gap between the front and second row large coal. Position the remaining 5 medium coals in the positions shown in figure 9.

To obtain the best visual appearance it may be necessary to make slight adjustments to the position of the coals.

NOTE: **Additional coals must not be used.** If any of the coals or the coal bed becomes damaged, lost or broken, replacements must be obtained before the appliance is used

TO LIGHT THE APPLIANCE

1. Pull the adjustment lever out, this will reduce the warming up period.
2. Press and turn the gas control until the indicator mark is aligned with the IGN mark and keep the control fully depressed.
3. After a sufficient period has elapsed to allow the system to be purged of air, press and release the igniter button until a pilot flame has been established, (check that the pilot has lit on both the ports. Keep the control depressed for a further 20 seconds.
4. Release the gas control and check that the pilot remains lit.
5. Depress the gas control slightly and turn fully anti-clockwise until the indicator mark is aligned with the small flame symbol. The burner will cross light from the pilot.
6. Depress the gas control slightly and turn clockwise until the indicator mark is aligned with the large flame symbol. The burner will now be at maximum rate.
7. Turn the gas control to the OFF position, wait for 3 minutes, fully depress the gas control, turn to IGN position and release the control. Attempt to ignite the pilot with an already lighted match or taper. If the pilot ignites the FSD is faulty.
8. Re-light the appliance. With the adjustment lever pulled forward and the control set to the maximum rate (large flame) position, place the Fire front & fret in position and leave to heat up for 5 minutes, and check for satisfactory clearance of products by inserting a lighted smoke match into the opening in the position shown in Fig 10, i.e. 100mm below the top, and 40mm inside of the front face of the opening. All the smoke must be drawn into the flue. If spillage occurs, allow a further 10 minutes. Should spillage still occur examine the chimney for the fault and rectify the cause. The test should be repeated if an extractor fan is situated in the room, or in any connecting room, with all the doors in that room opened.
9. Remove the Fret and push the flame adjustment lever inwards, replace the Fret and check that the flame picture changes to a longer softer flame.

Demonstrate the lighting and extinguishing procedures to the user.

ADVISE THAT:

The curing effect of heating the coals will cause an initial odour, which although not harmful, may require additional ventilation until the odour has disappeared.

The appliance must be serviced annually by a competent person; i.e. a CORGI registered installer in accordance with these instructions and that the appliance is checked for spillage in accordance with the method detailed in these instructions.

The appliance is fitted with an Oxy-pilot to prevent the continued operation in the event of spillage occurring. If the fire shuts 'OFF' repeatedly the appliance must be turned off and not used until an expert is consulted.

Advise the customer that they should read their Users Instructions before operating the fire and always follow the advice in the section headed 'Removal of Debris or Soot Deposits'

Complete the section in the enclosed registration leaflet. Advise that any component or part of this appliance is guaranteed against defective workmanship or faulty materials for a period of twelve months from the date of purchase.

Any such part will be replaced free of charge on receipt of the purchasers address at the cost of postage only, provided that:

It is accompanied by the registration section cut out of the booklet together with the original purchase receipt, which will be returned with the replacement part.

- a) A competent person has carried out installation repairs or adjustments, such as the supplier's representative or a CORGI registered installer.

MAINTENANCE AND SERVICING

GENERAL

A. REMOVAL OF DEBRIS OR SOOT DEPOSITS;

Allow the appliance to cool for one hour before removing all the coals and coal bed components for cleaning purposes. Once all the components have been removed from the fire bed check that no debris has become lodged in the burner ports (both front and rear). If any debris is present it may be easily removed with a thin piece of card or similar to ease out any foreign matter. To ensure that the release of fibres from these RCF articles is kept to a minimum, during installation and servicing we recommend that you use a HEPA filtered vacuum to remove any dust and soot accumulated in and around the fire before and after working on the fire. When replacing these articles we recommend that the replaced items are not broken up, but are sealed within heavy duty polythene bags, clearly labelled as RCF waste. This is not classified as "hazardous waste" and may be disposed of at a tipping site licensed for the disposal of industrial waste. Protective clothing is not required when handling these articles, but we recommend you follow the normal hygiene rules of not smoking, eating or drinking in the work area and always wash your hands before eating or drinking. Any soot deposits may be removed from either the Thermocouple or Electrode tips with a soft cloth, **do not use abrasive materials.**

B. SERVICING COMPONENTS BELOW THE BURNER ASSEMBLY

To remove trim, lift vertically to allow the formed tags in the rear of the trim to slide out of the notches in the flanges of the box. (Assemble in the reverse sequence). Remove the coals, coal supports, burner inserts and front simulated coal. To gain access to the components below the burner assembly it has to be removed from the Vent Box by disconnecting the gas supply at the inlet elbow and unscrewing the two screws at the base of the fascia panel. Where the supply is fed from the right hand side across the front of the appliance it will be necessary to disconnect the supply from the isolation tap or restrictor elbow.

i) **TO CLEAN OR REPLACE THE INJECTOR:** Unscrew the compression nut connecting the gas supply to the injector elbow while supporting the injector to prevent any distortion of the frame work. Unscrew and remove the gas supply tube from the gas control valve, hold the injector lock nut with a spanner and rotate the injector. Replace in the reverse order.

ii) **TO REPLACE THE GAS CONTROL / FSD:** Disconnect the three gas pipes and the thermocouple from the gas control. Pull the control knob from the spindle, unscrew the lock nut securing the front of the control valve (niting plate assembly), and remove the gas control valve. Replace in the reverse order.

iii) **TO REPLACE THE PIEZO IGNITER:** Pull the igniter lead from the piezo igniter tab. Hold the piezo lock nut and rotate the piezo to unscrew and remove. Replace in the reverse order.

iv) **TO REPLACE THE OXY-PILOT ASSEMBLY:** The assembly is not an item that can be serviced as part of its calibration depends on the proximity of the spark electrode and thermocouple tip. The assembly can be replaced by removing the tube nut and the tube from the base of the pilot, the thermocouple from the FSD, the igniter lead and the two M4 screws securing the bracket to the framework. Replace in reverse order, the spark gap is shown in figure 12.

v) **PROTECTIVE SIDE PLATES;** These stainless steel plates are pushed over the flanges of the fibre retaining channels and can be replaced if required.

FIRE FRONTS & FRETS SUITABLE FOR THIS APPLIANCE.

The illustration shown is the recommended MACH II Front and Fret, if an alternate Front and Fret is used, it is important to maintain the equivalent ventilation to that shown. Fronts and Frets are available under the following part numbers: -

TYPE	GC No	CODE No	TYPE	GC No	CODE No
MACH 11 BLACK	32 183 25	C022G	JB BLACK	32 183 38	C019G
MACH 11 BRASS	32 183 48	C024G			

SPARES AND SERVICE

For spares and service, apply to your local Supplier, Installer or direct to the manufacturer, stating that the appliance is a Super Hot Toaster quoting the GC Appliance Number and Serial Number from the data badge located on the front controls panel.

Advantage should be taken of regular servicing and inspection for gas appliances to ensure their continued safe operation.

SHORT PARTS LIST

Description	Crosslee No	GC No
Piezo Igniter	40245	397 686
Control Knob	40232	
Control Valve	41833	
Oxy-Pilot Burner Assembly	42313	170 415
Main Injector	41180	389 515
Coal Support	43010	
Burner Inserts	42952	
Front Simulated Coal	40481	
Set of Coals	43011	
Protective Side plates	41072	170 249

Maximum Heat Input (Gross)

6.95 kW 23700 Btu/h

Royal Cozyfires are manufactured by:

CROSSLEE plc
Aber Park Industrial Estate,
Aber Road, Flint, Flintshire. CH6 5EX
Spares Tel 01422 203963
Fax: 01422 204475
Service (GSA Ltd) 01703 516611
Customer Service 01422 200660
Fax 01422 206304

*Technical Help Line 0906 8633268

*Calls charged at 60p per minute

Fig 1

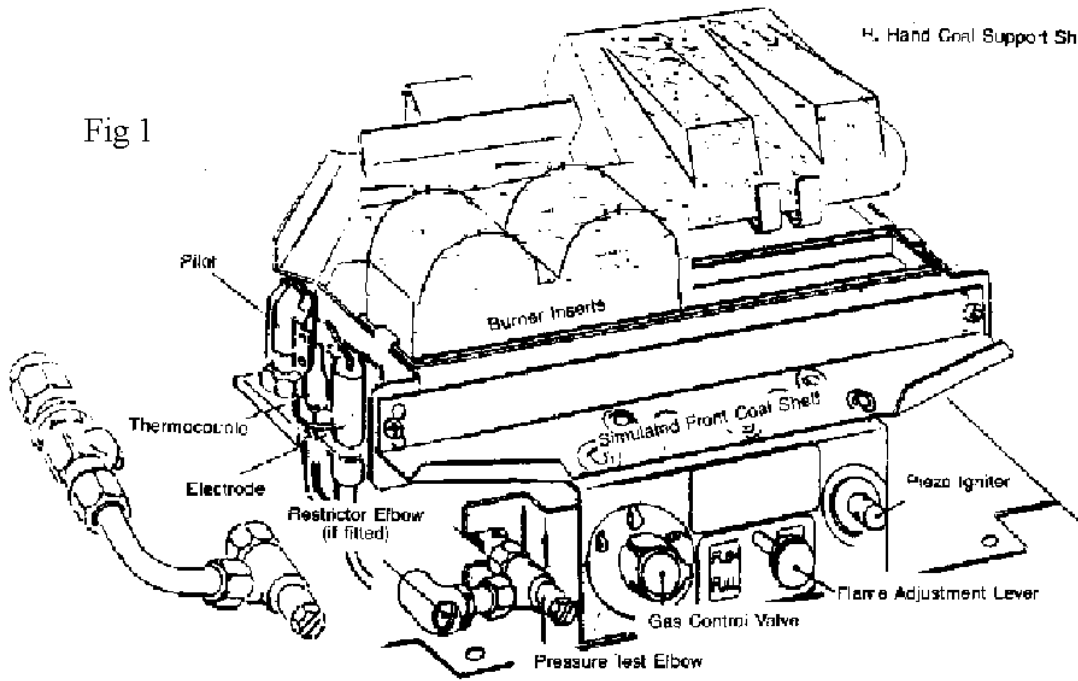

Fig 2

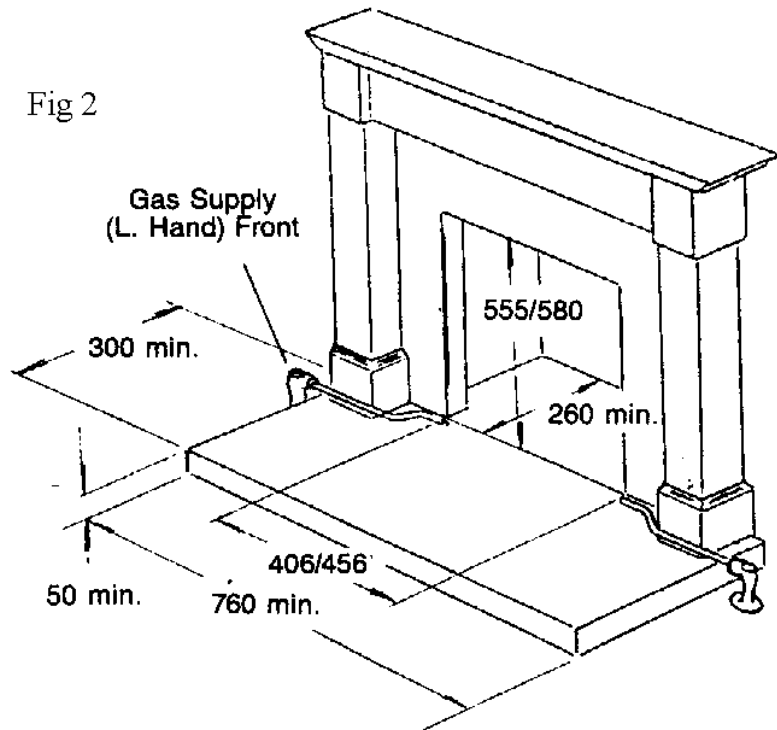
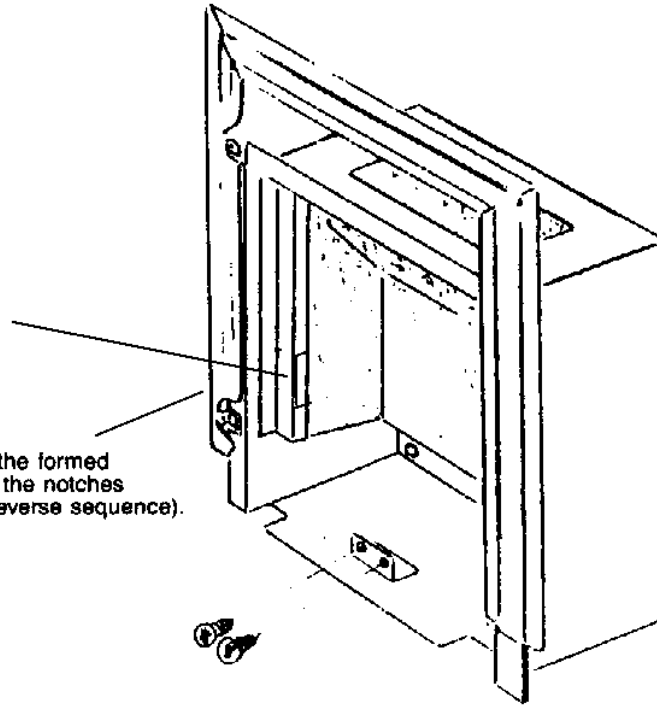

Fig 3

PROTECTIVE SIDE PLATES; These stainless steel plates are pushed over the flanges of the fibre retaining channels and can be replaced if required.

To remove trim, lift vertically to allow the formed tags in the rear of the trim to slide out the notches in the flanges of the box. (Assemble in the reverse sequence).



Remove screws to exact burner assembly.

Fig 4

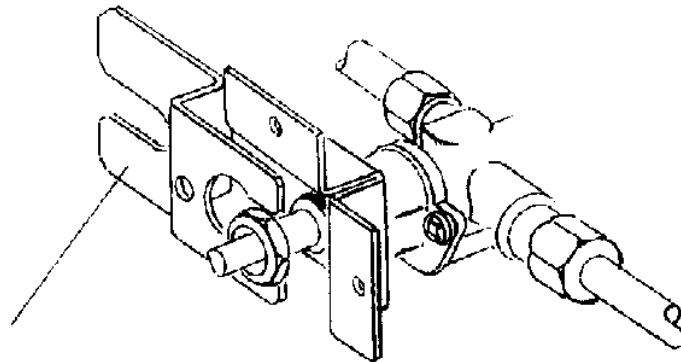

To remove the supply tube support bracket, unscrew the Control Valve lock-nut and lift the bracket over the spindle.

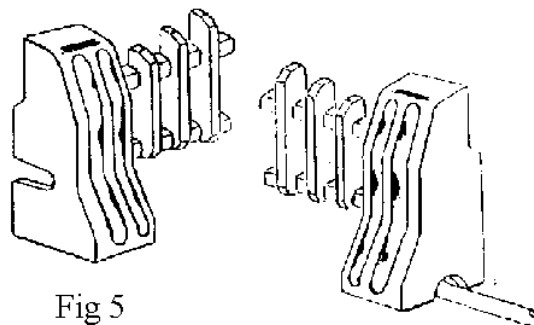
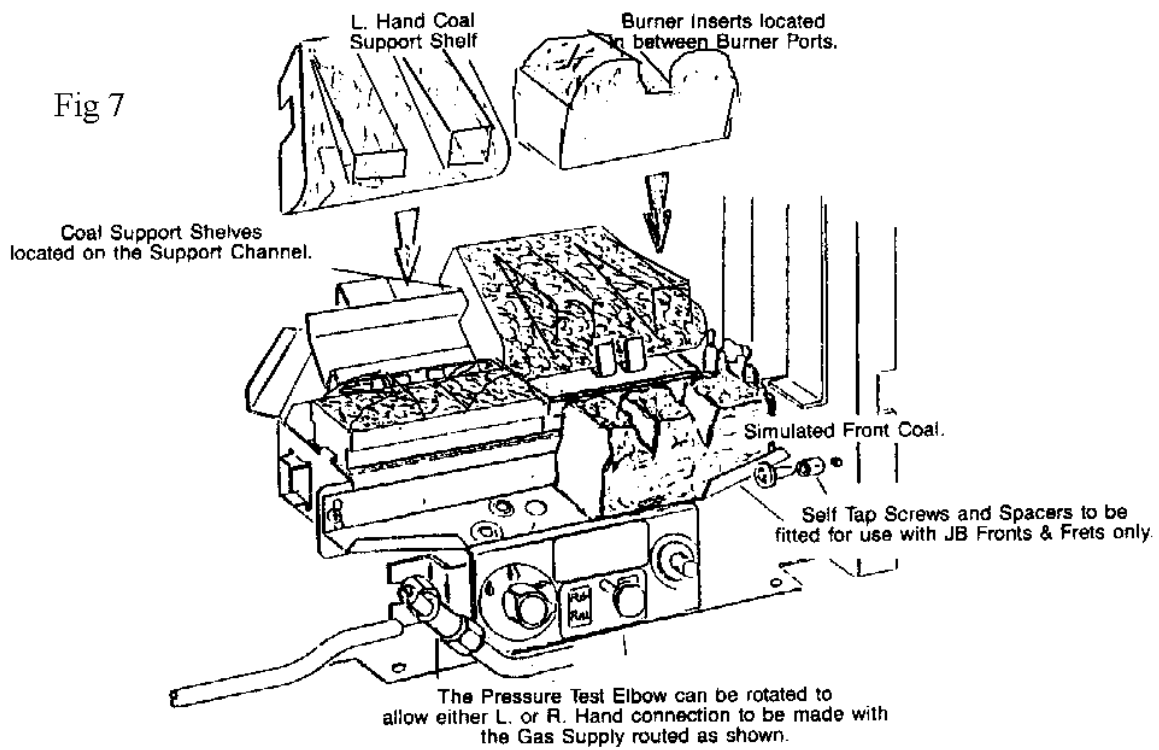

Fig 5

No Fig 6 issued with this document



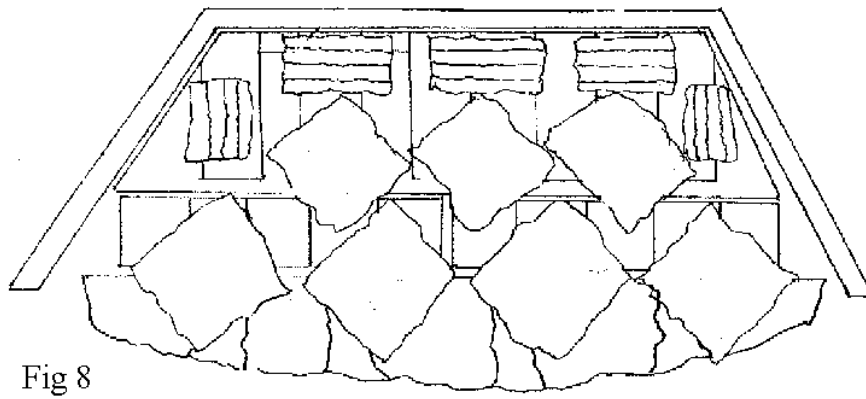

Fig 8

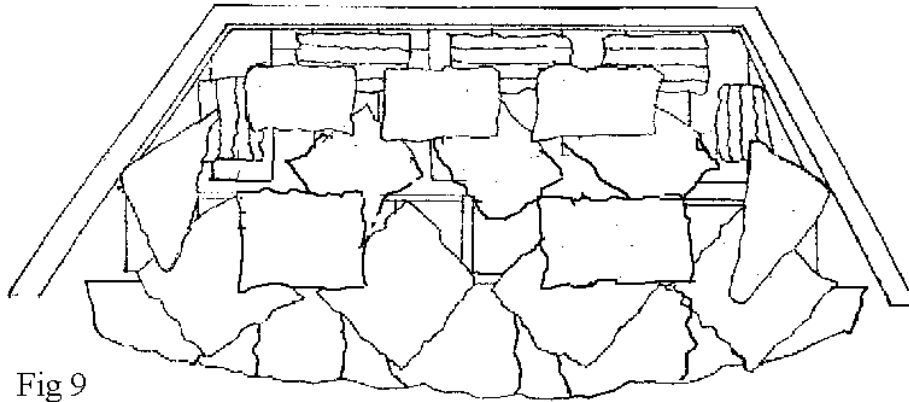
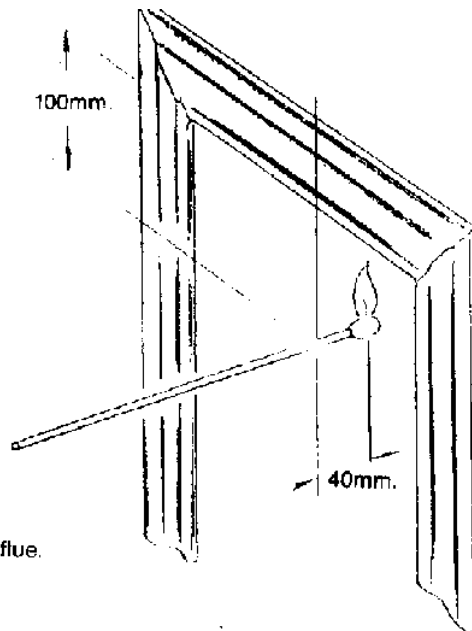

Fig 9

Fig 10



Hold a Smoke Match in the position shown all the smoke must be drawn into the flue.

Material
Cast Iron
Brass

Finish
Black Paint
Polished

Code No.
CO22G
CO24G

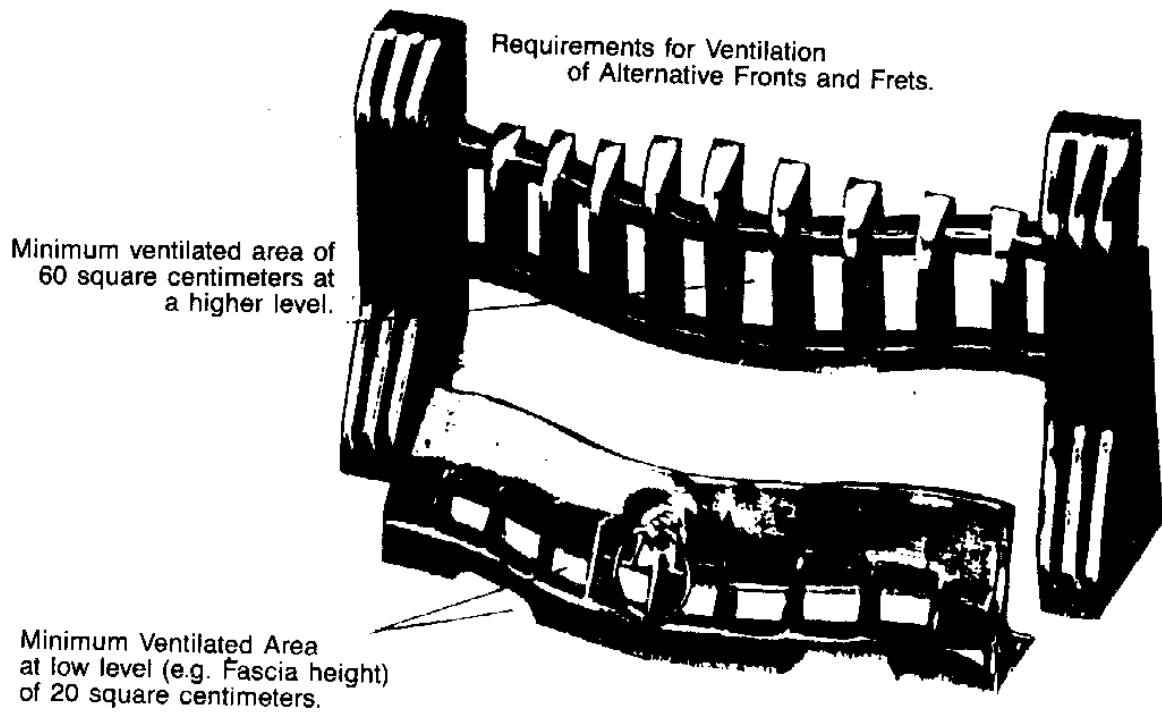

Type
JB Black

GC No.
32 183 38

Code No.
C019G

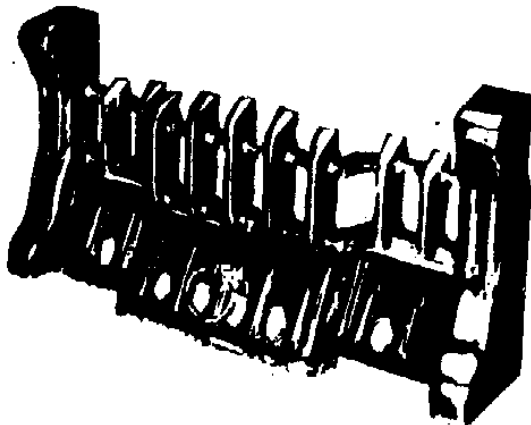

Fig 11

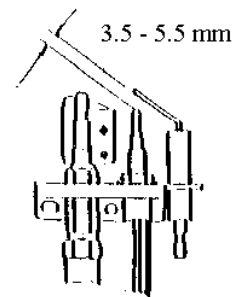

Fig 12

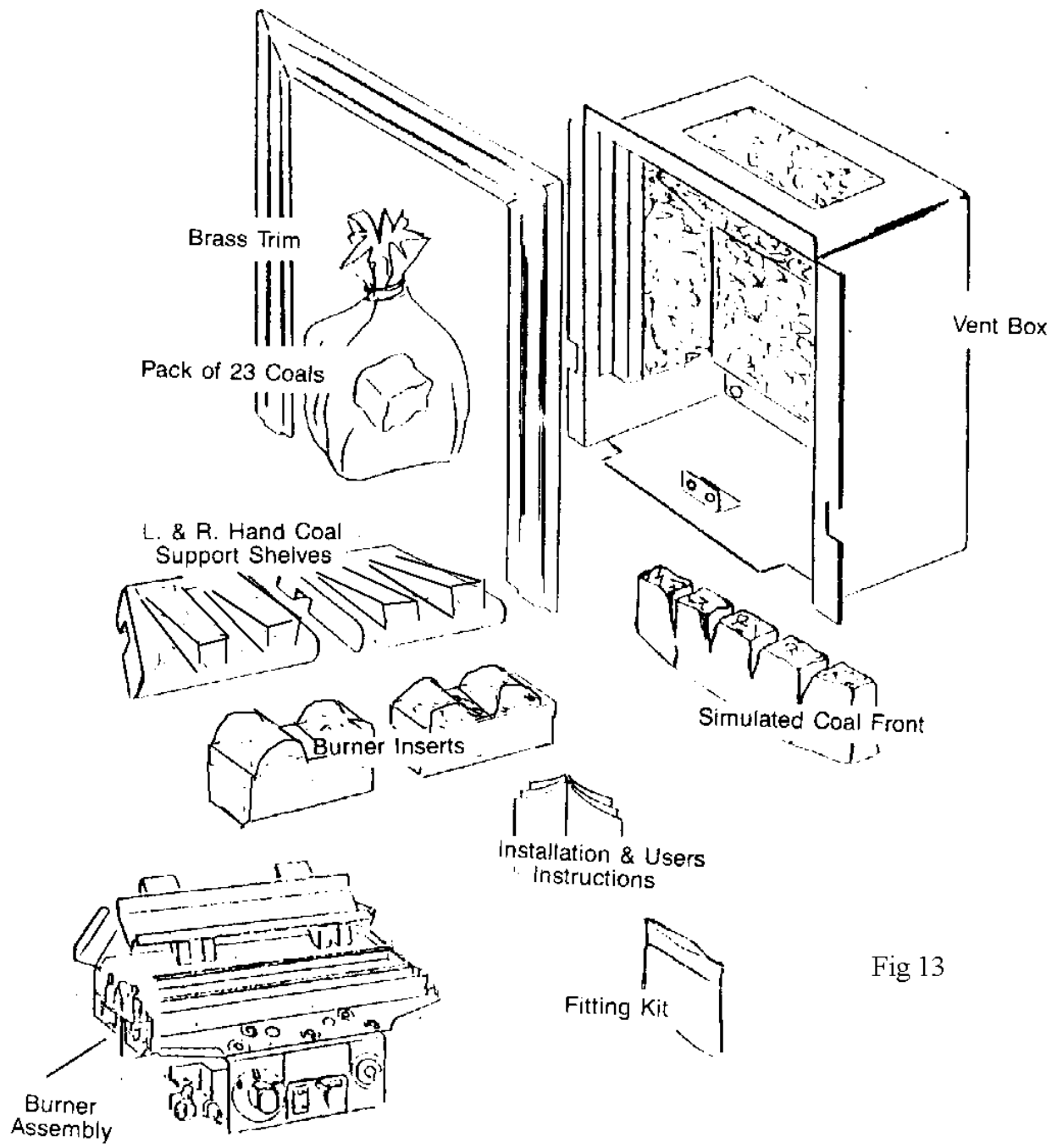

Fig 13