



Operation Manual

CXW-200-A818

CXW-200-A809

Rangehood

Contents

Warning and Safety Instructions.....	2
Product Specifications.....	3
Installation Instructions.....	4
Using Your Rangehood.....	7
Care and Maintenance.....	9
Rangehood Technical Diagram.....	10
Electrical Diagram.....	10

Thank you for purchasing your new ROBAM Rangehood.

To get the maximum output from this unit, please read through this guide before use.

We trust that you will enjoy your new ROBAM rangehood.

Please always retain your proof of purchase to aid in any warranty queries.

WARNING AND SAFETY INSTRUCTIONS

Please read this section thoroughly before attempting to operate the appliance. Inspect your product upon receipt. Any damage or defects MUST be reported immediately.

DO NOT INSTALL THIS APPLIANCE IF YOU FIND IT DAMAGED.

If this product is installed damaged, neither the supplier, nor the retailer, will be responsible for the costs associated with the repair, replacement, removal or re-installation of the appliances.

Do not install this rangehood over burners that give off intense, uncontrolled flames.

This rangehood must be ducted to the outside atmosphere.

Do not flambé under the rangehood

The guide contains important information on the use and maintenance of the unit, as well as important safety notes. This will ensure your personal safety and the lasting value of your rangehood.

When necessary, also read the Operation Manual of your cooktop and keep them both in a safe place for future reference.

Young children must not be allowed to use this appliance.

Older children may only use the appliance when its operation has been clearly explained to them and they are able to use it safely, recognising the dangers of misuse.

PACKAGING OF YOUR NEW RANGEHOOD

This appliance and its packaging are produced by processes that minimise waste and respect the environment. Please help us to continue this effort to protect the environment by using the appliance efficiently and dispose of the packaging in a responsible manner.

Danger of suffocation! Children may be able to wrap themselves in packing material or pull it over their heads with the risk of suffocation. Keep children away from any packing material.

DISPOSAL OF YOUR OLD RANGEHOOD

Electrical and electronic appliances often contain materials which, if handled or disposed of incorrectly, could be potentially hazardous to human health and to the environment. They are, however, essential for the correct functioning of your appliance.

Please dispose of it at your local community waste collection / recycling centre.

Ensure that your old appliance presents no danger to children while being stored for disposal.

PRODUCT SPECIFICATIONS

Technical Specification

Model	CXW-200-A818 CXW-200-A809	Maximum Noise Level	≤ 57.5dB(A)
Power Supply	220-240V ~ 50Hz	Rated Total Input Power	204W
Full Pressure Efficiency	≥ 23%	Rated Motor Input Power	200W
Nominal Pressure	≥ 280Pa	Maximum Lighting Power	≤ 4W
European Standard Maximum Airflow Rating	1140m ³ /hr	Dimensions (L x W x H)	A818: 895 x 504 x 652 (mm) A809: 895 x 524 x 597 (mm)
Maximum Static Pressure	≥ 350Pa	Net Weight	A818: 26kg A809: 25.5kg
Odour Decrease Rate (Normal)	≥ 98%	Grease Separation Rate	≥ 96%
Odour Decrease Rate (Instantaneous)	≥ 80%	Minimum Distances	Cooktop: 650mm Barbeque: 800mm

Note:

1. Airflow rating in accordance to European Standard EN61591 $\Phi 150$, 175
2. The deviation between expressed value of air volume or maximum static pressure and measured value shall not be larger than 10% of the expressed value.

Figure 1

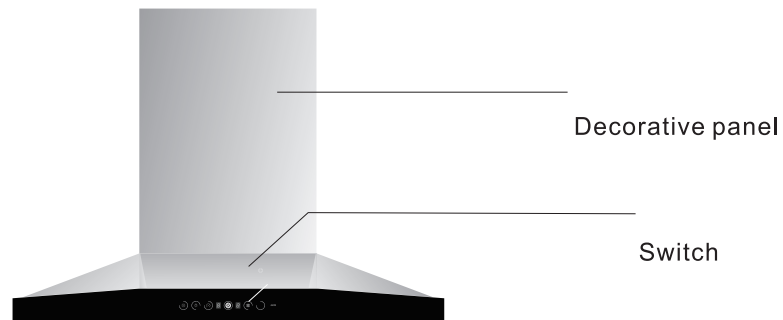

Figure 2



(Unit: mm)

INSTALLATION INSTRUCTIONS

Installation Warning

1. Exhaust air must not be discharged into any chimney or flue, which may carry combustible products from other sources.
2. It is dangerous to modify any part of this appliance. Modification of any kind will immediately void the warranty.
3. Verify that the indicated electrical data coincide with the voltage values and frequency of the electrical circuit in the house where the rangehood is to be installed.
4. This appliance must be connected to an electricity supply with a ground connection.
5. Check that the installation and electrical connections are made by a qualified technician and that the indicated instructions and local regulations in force are met, using materials that are compliant with the applicable legislation.
6. Ensure the supply cord is not exposed to heat, chemicals or sharp objects. If the supply cord is damaged, it must be replaced by the manufacturer, service agent or a similarly qualified person in order to avoid a hazard.
7. Check that the premises has electrical protection against short circuits and electrocution, pursuant to the applicable legislation
8. Ensure that the location in which this appliance is installed, has good and permanent ventilation.
9. Please consult local laws and regulations and install accordingly.
10. Do not connect this rangehood to a power source during installation.
11. The stainless steel on the rangehood may have very sharp edges, please wear protective gloves while moving the rangehood for installation, cleaning or maintenance.
12. Make sure the rangehood body is level during installation.
13. Do not reduce the duct size or have sharp bends, enlarge the duct size if the duct is to run 6 metres or longer. Reducing the duct size will affect the rangehood's performance.
14. The duct should be as short and straight as possible.
15. Only use wide radius bends.
16. Incorrect venting will result in additional noise and a reduction in efficiency.
17. Side drafts will push the cooking smoke away from the capture area therefore affecting the performance of the rangehood.
18. Always use non-flammable materials to minimise the risk of fire.
19. Some parts of the rangehood may become hot when cooking.
20. This appliance is not intended for use by persons (including children) with reduced physical, sensory or mental capabilities, or lack of experience and knowledge, unless they have been given supervision or instruction concerning use of the appliance by a person responsible for their safety.

Accessories

Name	Quantity	Name	Quantity
Rangehood	1 piece	ST4x18 Self Tapping Screws	10 pieces
Non-Return Valve	1 set	ST4.8x50 Timber Screws	4 pieces
Valve Seal		Solid Wall Plug	4 pieces
Valve connector		M6 Solid Wall Anchor	1 piece
Wall Bracket	1 piece	Stopper Foot	1 piece
Oil Cup	1 piece	Semi-Rigid Duct with Tape	1 piece
User Manual	1 piece	Reducing Collar	1 piece

Installation

Determine the Position.

1. When deciding on the safety distance between the cooktop and rangehood, please note that a minimum distance of 650mm must be kept between the bottom of the rangehood to the top of trivets of cooktops.
2. When installing your rangehood over a barbeque, a minimum distance of 800mm must be kept between the bottom of the rangehood to the top of the grill plate.
3. Account should also be taken of the height of the person who will be using the rangehood most often.
4. They should have sufficient space to work comfortably at the cooktop, and be able to reach the rangehood controls with ease.
5. If positioned too high, extraction will be inefficient.
6. To achieve optimum extraction, the rangehood must cover the cooktop. It should be positioned centrally over the cooktop, not to the side.
7. The cooktop should be no wider than the rangehood, and if possible, it should be narrower, especially for distances greater than 800 mm.
8. The installation area must be easily accessible. The rangehood should be easily accessible and easy to dismantle in the event that service is required. This should be taken into consideration when planning the position of cupboards, shelves, ceilings or features in the vicinity of the rangehood.

Figure 3.1

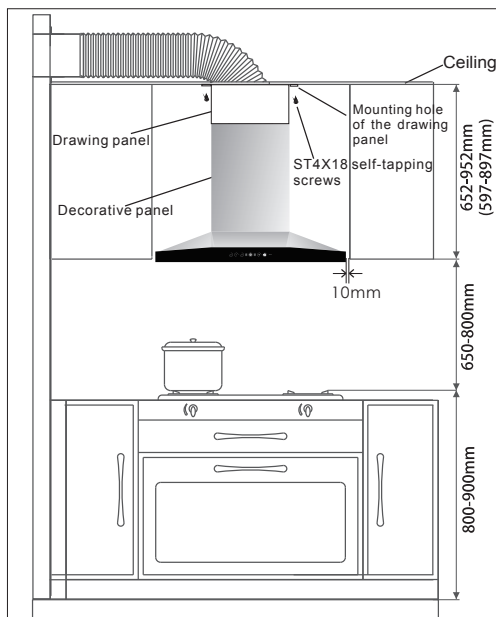

Figure 3.2

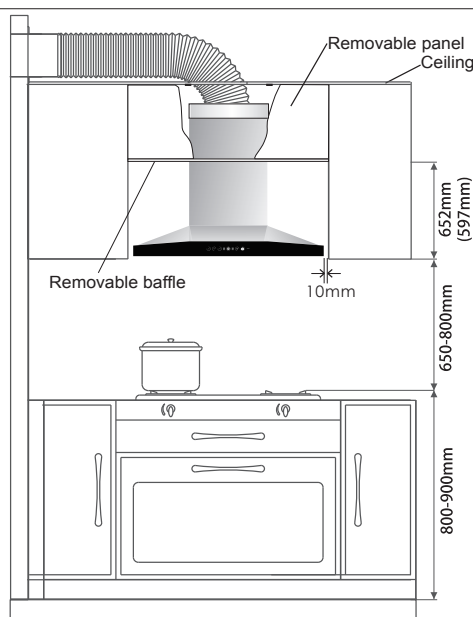
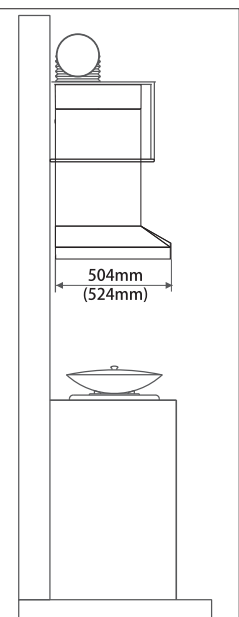

Figure 3.3



Note: Figures in brackets are specific to the cupboard size of A809 rangehood.

Installation of Wall Bracket

Using a spirit level mark a vertical centre line on the wall where the rangehood is to be positioned, and a horizontal line to mark where the holes will go to mount the wall bracket. (Shown in Figure 4.1).

Warning

Due to the heavy weight of the rangehood, always mount the wall bracket securely on a wall. E.g. On concrete wall or on timber studs, NEVER mount only on plasterboard.

Note: The large screws and plugs are designed for use in solid walls only. For other types of wall construction, alternative fixings will be required. Always make sure the wall is able to take the weight of the rangehood.

Figure 4.1

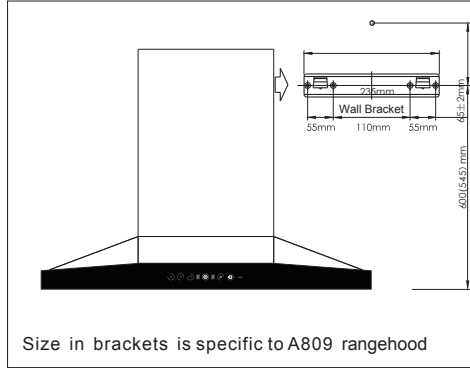

Figure 4.2

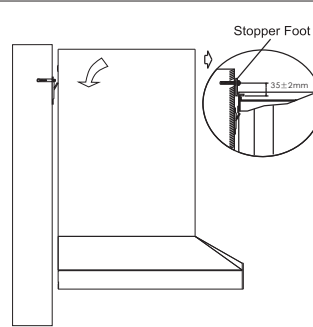

Figure 4.3

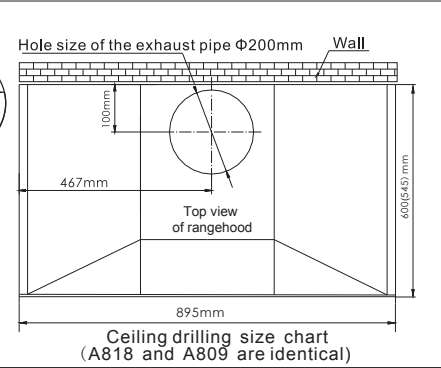

Figure 5.1

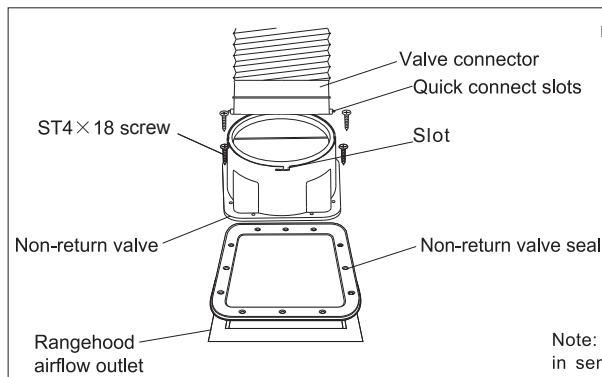
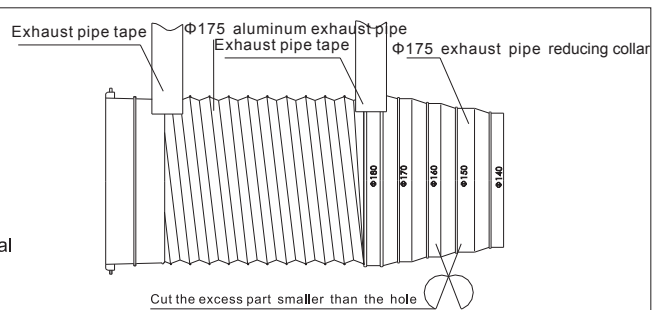

Figure 5.2



Note: During installation, straighten the aluminum exhaust pipe to avoid noises in semi-stretched state. Excess part may be cut with a wire cutter.

Check the Flue Cover

Pull out the flue cover from the top of the rangehood and remove the protective film. Check the height of the flue cover plus the body of the rangehood to make sure the height is sufficient for your installation, then carefully slide the flue cover back into position. (Shown in Figure 3.1)

Warning

The edges of the stainless steel are very sharp, ALWAYS wear protective clothing and gloves when handling any part of the rangehood during installation.

If you require an extension flue cover (sold separately), please contact your local ROBAM Customer Support before installing the rangehood.

Install the Non-Return Valve

Place the non-return valve seal on the rangehood outlet and screw the non-return valve housing on the rangehood with the small screws provided. Tape the semi-rigid duct to the non-return valve connector to be used when installing the ducting. (Shown in Figure 5.1)

Warning

All rangehoods must be ducted to the external atmosphere, ducting to the ceiling cavity can cause a fire hazard.

Note: To ensure optimum performance of the rangehood, rigid or semi-rigid duct is recommended. The use of sharp right angle bends should be avoided where possible. During installation, straighten and pull the duct tight to reduce movement of duct to avoid excess noise. Excess duct may be cut with a wire cutter. Do not reduce the diameter of the duct where possible as this will reduce the airflow of the rangehood.

Note: Some situation where the duct must be connected to an existing outlet with a different diameter (e.g. central exhaust system in an apartment), the reducing collar may be used. The diameter of the reducing collar are OD 180, 170, 160, 150, 140mm respectively, any part of the reducing collar not needed will need to be cut away. (Shown in Figure 5.2)

Install the Rangehood

After the duct is installed, hang the rangehood onto the wall bracket by the pre-cut slots on the top rear of the rangehood. (Shown in Figure 4.2)

Make sure the rangehood is securely hang into place, then install the stopper foot on the wall to stop the rangehood from being lifted off accidentally or from external forces. (Shown in Figure 4.2)

Connect the duct to the rangehood via the connector, line up the slots to the valve and rotate clockwise to secure it into position.

Plug in the rangehood to a wall socket and turn it on, for touch control models, you will hear an audible tone. Your rangehood is now powered on and in standby mode.

Slide up the flue cover and screw it into position to cover the duct and the electrical cord.

Remove all protective film from the rangehood.

Your rangehood installation is now complete.

USING YOUR RANGEHOOD

Switch Control Panel

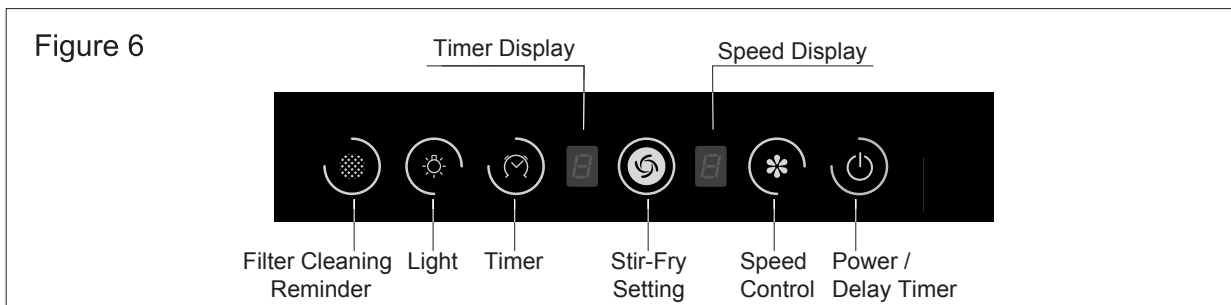

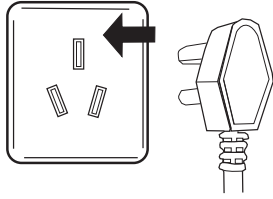

- Plug in the rangehood and a tone from the rangehood will indicate the rangehood is now in standby mode. (This picture is for reference only, plug is subject to change for different counties)

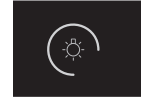

Light

- Press the light button to turn the LED light on, press light button again to turn it off. Each press will trigger a tone from the rangehood. The light button only controls the light.



Power

- When the power icon is lit up and only LED light is on, press the power button and the light will be turned off. If the fan is running, press the power button once, the power button will flash and the rangehood will go into delay timer mode, the fan will automatically shut down after 1 minute. While the power button is flashing, press the power button again to turn off the rangehood immediately.



Stir-fry Setting Speed Control

- While the power button is lit up, press the stir-fry button to instantly achieve maximum airflow with the speed display showing 6. Stir-fry setting will last 3 minutes and automatically switch to level 3. At this time, you may adjust the speed via the speed control. Each press will trigger a tone from the rangehoods and decrease the airflow by one level.



Timer

- Press the timer button when the fan is running, the timer display will increase between 1 to 6, by multiples of 10 minutes, 1 is for 10 minutes going upto 6 for 60 mins. After the set time, the timer will act like a alarm clock and will beep to remind you to come back. While the alarm is ringing, press any button to cancel the alarm. While the timer is active, changing the fan speed will reset the timer.



Filter Cleaning Reminder

- This rangehood is equipt with a filter cleaning reminder . The reminder light will come on and a tone will sound to remind you to clean the filter. The reminder is set on a continuous running timer of 60 hours. While the remind light is on, you can hold the button to cancel the remind or the reminder light will automatically turn off after 1 hour.

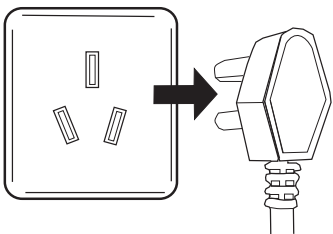

- If you are going to be away from a extended period of time, please unplug the rangehood from the power plug. (This picture is for reference only, plug is subject to change from different counties)

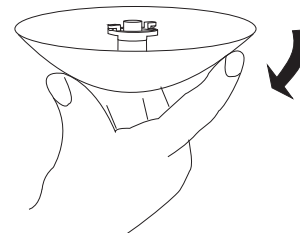

- When the grease and moisture collected in the oil cup reaches 2/3 full, please remove and clean the oil cup to prevent dripping and spillage.

CARE AND MAINTENANCE

The rangehood surface should be cleaned with soft cloth and non-corrosive detergent. Do not leave the rangehood wet after cleaning or use, please keep the rangehood dry.

IMPORTANT: Never attempt to repair this appliance by yourself. Always refer to a qualified Service Technician. Always switch off the electricity and unplug the connection before conducting maintenance or cleaning.

General Cleaning

All external surfaces and controls can be cleaned using warm water with a small amount of dish washing liquid. Applied with a well wrung-out soft sponge or cloth.

IMPORTANT: Do not use too much water when cleaning around the control area, Water could penetrate into the electronics and cause damage and electrocution.

IMPORTANT: After cleaning, wipe all surfaces dry using a soft cloth.

DO NOT USE:

Cleaning agents containing soda, acids, chlorides, or solvents.

Abrasive cleaning agents, (e.g. powder cleaners or cream cleaners) and abrasive sponges, as well as pot scrapers or sponges which have been used previously with abrasive cleaning agents. These will damage the surface material.

Stainless Steel Cleaning

Stainless steel surfaces can be cleaned with a proprietary nonabrasive cleaning agent designed specifically for use on stainless steel.

Follow the manufacturer's instructions on the packaging. Apply sparingly with a soft cloth following the instructions on the packaging.

IMPORTANT: Always make sure wiping is done along with the grain of the stainless steel to prevent any unsightly crisscross scratching patterns from appearing

Controls Cleaning

Do not leave soiling on the controls for any length of time. Otherwise they may suffer discolouration or damage. Remove any soiling immediately. Glass controls panels can be cleaned using a proprietary non-abrasive cleaning agent designed specifically for use on glass.

Observe the general notes on cleaning earlier in this section.

IMPORTANT: Do not use stainless steel cleaning agents on the controls or glass panel.

Filter Cleaning

The oil filter, oil guide and oil cup can be cleaned by hand in warm soapy water. Soak in warm water and some dishwashing liquid. For stubborn grease stains use a soft nylon brush to help remove these stains.

All 3 parts of the filter are dishwasher safe. Ensure that the placement of the filters is made so as to not impede the function of the spray arm.

After cleaning, ensure that the filters are completely dry before refitting.

Warning: An oversaturated filter is a fire hazard.

Unsuitable Cleaning Agents

Unsuitable cleaning agents can cause damage, do not use:

1. Cleaning agents containing descaling agents
2. Powder cleaners or cream cleaners
3. Aggressive all-purpose cleaning agents or spray cleaners for grease
4. Oven sprays
5. Cleaning agents containing soda, acids, chlorides, or solvents.

RANGEHOOD TECHNICAL DIAGRAM

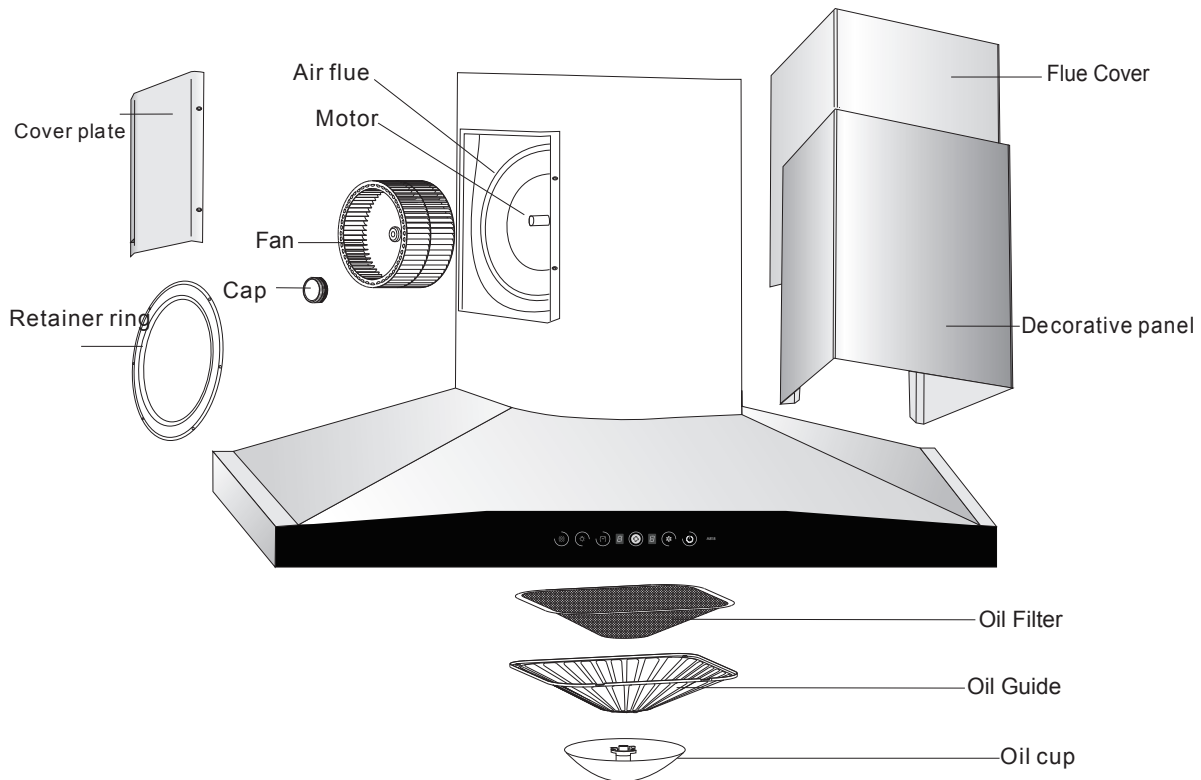

ELECTRICAL DIAGRAM

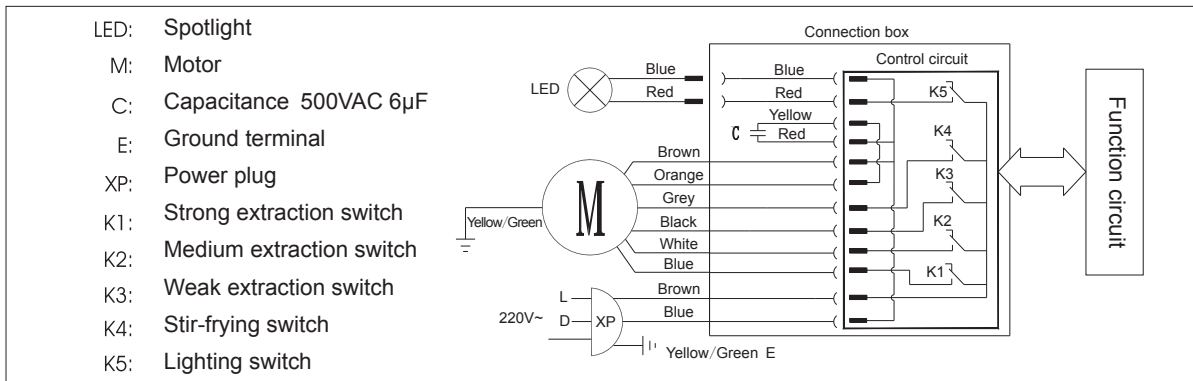

ROBAM