



The VPC Range

User, Installation and Servicing Instructions

TESTED		
STAGE 1	Full mechanical, construction, assembly and electrical sequence check	<input type="checkbox"/>
STAGE 2	Full functional test in accordance with Quality System Procedures	<input type="checkbox"/>
Heater Model	_____	Final <input type="checkbox"/>
Heater Serial No.	_____	
Type of Gas	_____	

WARNING: THIS APPLIANCE MUST BE EARTHED

£2.50 When supplied separately.



powrmatic

Certificate of Guarantee



Dear Customer

This is to certify that this appliance is guaranteed for two years including parts and labour from the date of original commissioning.

The heat exchanger, where fitted, is guaranteed (parts only) for a further eight years, chargeable on a sliding scale basis, price relative to age.

To make a claim

In the first instance you must contact your appliance supplier, or installer and provide:-

1. The appliance type and serial number.
2. The original commissioning documentation.
3. As much detail as possible on the fault.

Your supplier, or installer will then contact Powrmatic to make a guarantee claim on your behalf.

Conditions of Guarantee

1. The appliance must have been installed by a competent recognised installer, and in accordance with the manufacturers instructions, building regulations and local regulations.
2. The appliance has been professionally commissioned.
3. The appliance has been maintained on a yearly basis by a competent servicing company.
4. The appliance has been used in accordance with the manufacturers instructions.
5. The correct specification fuel has been used
6. No unauthorised repairs or modifications have been made.
7. Powrmatic 'General Conditions of Sale' have been observed.
8. Except for the obligation of Powrmatic Ltd to perform warranty repairs during the guarantee period, Powrmatic will not be liable in respect of any claim for direct or indirect consequential losses, including loss of profits or increased costs arising from loss of use of the appliance, or any event arising there from.

Exclusions

1. Gaskets and fan belts are not included in the guarantee

Powrmatic Ltd, Hort Bridge, Ilminster, Somerset, TA19 9PS
tel: 01460 53535 fax: 01460 52341
email: guarantee@powrmatic.co.uk web: www.powrmatic.co.uk

**Important: This certificate must
be kept with the appliance**

Users Instructions

1. First Start Sequence

Follow the sequence below before lighting the heater(s) for the first time.

- a) Ensure that the gas supply to the unit is turned OFF.
- b) Turn on the electrical supply to the heater and programme the controls in accordance with their instructions.
Note: The ignition sequence may start during this process but the heater will not light, as the gas supply is turned off, and the internal burner control will go to lockout. The lockout indicator on the external control will be illuminated.
- c) Ensure that the controls are not calling for heat i.e. the thermostat is at minimum or the clock control is set to an OFF period or the function switch is set to OFF.
- d) Check that all warm air delivery outlets are open.
- e) If necessary reset the internal control from lockout by pressing the reset button on the external control for 3 seconds.
- f) Check that the overheat reset button has not operated.
- g) Ensure that the Summer/Winter switch is in the Winter position.
- h) Turn ON the gas supply.

2. Lighting the Air Heater

NOTE:

On initial lighting of the heater(s), it may take some time to purge the internal pipework of air. If it is not possible to light the heater after several attempts contact the local service company.

1. Set the controls to call for heat and the ignition start up sequence will commence. The internal exhaust fan will run. When sufficient combustion airflow is proved by the air pressure switch the ignition spark will be generated and the main gas valves energized. The burners will then light.
2. If the burner fails to light the control box will attempt two further ignition attempts before going to lockout. The lockout light on the MC100 or Powrtrol will be illuminated (Note: If an integral MC100 or Powrtrol are not used a remote lockout indicator/reset will be fitted). To restart the ignition sequence depress the reset button on the control for at least 3 seconds. If the unit will not light after four or five attempts then shut down the unit and call in a service engineer.

3. To Shut Down the Air Heater

- 3.1 For Short Periods: Turn the room thermostat to the OFF or lowest setting.
- 3.2 For Long Periods: Complete step 3.1 above. Wait for 5 minutes and then turn OFF the electrical supply at the isolator.

4. Description of Operation

Important: All heaters must be controlled by the fitted external controls and not by use of the main switch in the electrical supply to the heater.

4.1 Standard Units

The ignition sequence will commence each time that the external controls e.g. Timeclock, room thermostat etc. call for heat. Approximately 15 - 30seconds after the main burners light the heater fan will be automatically started. When the external controls are satisfied the main burners will be turned off and approximately 2 - 3 minutes later the heater fan will be automatically stopped.

4.2 High / Lo & Modulating Units

When the main burners are alight the heat output will be controlled either to high fire or low fire or, in the case of modulating units, to any point between high and low fire; depending on the requirements of the space being heated and the control system.

4.3 Summer / Winter Modes

The integral MC100 or Powrtrol controls, and certain types of external controls, will provide for two modes of operation i.e. Summer: The heater fan alone will run at the dictate of the external controls to provide air movement.
Winter: The heater will operate normally.

5. Maintenance

Regular servicing is essential to maintain efficient, reliable and safe operation of the heater. Users are strongly recommended to have the heater serviced by a qualified person at least annually and preferably at the end of the heating season.

6. IMPORTANT

Free access must be maintained to and around the heater for servicing purposes and the air supply to the heater must not be restricted in any way. Combustible materials must not be stored adjacent to the heater.

If at any time a gas leak is suspected turn OFF the gas supply - DO NOT USE A NAKED FLAME - and contact the local gas undertaking immediately.

All Powrmatic heaters use gas and electricity to power them, they may also contain moving parts such as pulley belts. It would be hazardous to tamper with or attempt to service unless you are a competent person in the field of Gas and Electrical work.

If you have any safety questions reference the servicing and installation of any of our heaters please do not hesitate to contact our head office for expert advice.

Your safety is paramount to us.

Gas Safety (Installation & Use) (Amendment) Regulations

It is law that all gas appliances are installed, adjusted and, if necessary, converted by qualified persons* in accordance with the current issue of the above regulations. Failure to install appliances correctly can lead to prosecution. It is in your own interests and that of safety to ensure that the law is complied with.

* e.g. Corgi Registered

CONTENTS

<i>Section</i>	<i>Title</i>	<i>Page</i>
1.	Introduction	1
2.	Technical Data	2
3.	General Requirements	4
4.	Installation	5
5.	Air Distribution System	6
6.	Commissioning & Testing	7
7.	Servicing	8
8.	Fault Finding Flow Chart	10
9.	Wiring Diagrams	11
10.	Short List of Parts	11

<i>Tables</i>	<i>Title</i>	<i>Page</i>
1.	Dimensions	2
2.	Specifications	3
3.1	Injector Sizes & Burner Pressures	
	Natural Gas - Group H - G20	3
4.	Electrical Loadings 1ph	4

<i>Figure</i>	<i>Title</i>	<i>Page</i>
1.	Minimum Clearance Distances	5
2a.	Exhaust only System - Horizontal	7
2b.	Exhaust only System - Vertical	7
3a.	Individual System - Horizontal	7
3b.	Individual System - Vertical	7
5.	Controls Layout	8
6.	Honeywell VR425AB1007	9
7.	Honeywell VR4605AB1027	9
8.	High/Lo and Modulating Heads	9
9.	Ignition Electrode Spark Gap	10
10.	Thermostat Fan/Limit - Honeywell L4064N	10

1. INTRODUCTION

The VPC range are highly efficient gas fired, fanned circulation floor standing air heaters that cover heat outputs of 30kW to 130kW. The units have a single closed flue system that can be either vertical or horizontal and feature a single burner assembly which, as standard is ON/OFF but can also be supplied in High/Low or Modulating formats. High/Low or Modulating formats give a turn down facility of approximately 2:1. The heaters are certified for use on Natural Gas, Group H - G20, and Propane - G31 only. Appliance Categories are Cat II2H3P (GB, IE).

The heaters intended primarily for heating commercial or industrial premises. They must not be used where the atmosphere inside the premises could be contaminated e.g. Dust, oil mist etc. or in areas classified as hazardous as defined in BS 5345: Part 2. They are not suitable for siting externally.

VPC heaters have a centrifugal fan assembly fitted at the base of the heater to circulate the air being heated past the folded tube heat exchanger.

Heaters are fitted as standard with one set of atmospheric inshot burners having a fully automatic control for ignition, flame sensing, gas supply control and safety functions and an internal exhaust fan, as well as the main air fan(s) and limit thermostat.

Gas Safety (Installation & Use) Regulations

It is law that all gas appliances are installed, adjusted and, if necessary, converted by qualified persons* in accordance with the current issue of the above regulations. Failure to install appliances correctly can lead to prosecution. It is in your own interests and that of safety to ensure that the law is complied with.

* e.g. Corgi Registered

2. TECHNICAL DATA

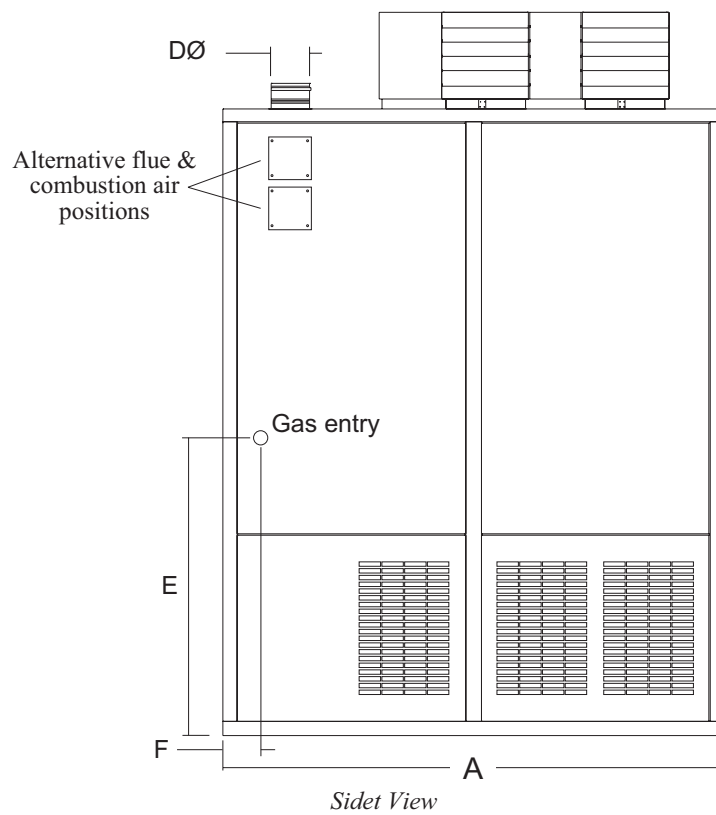
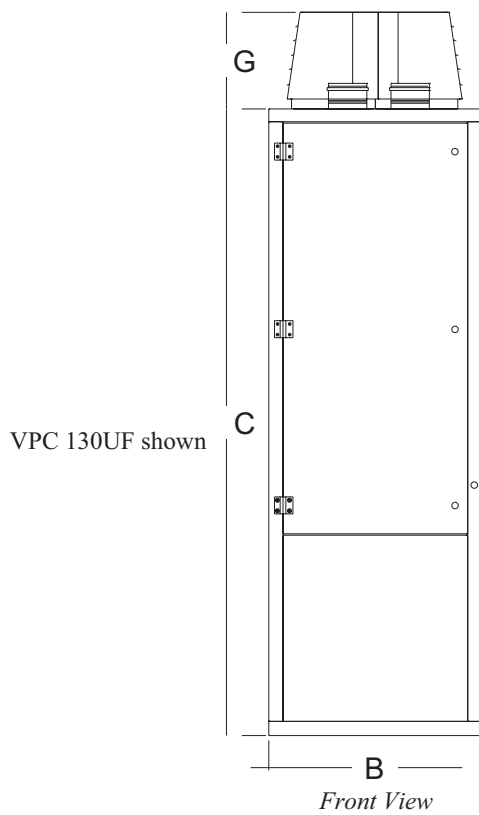
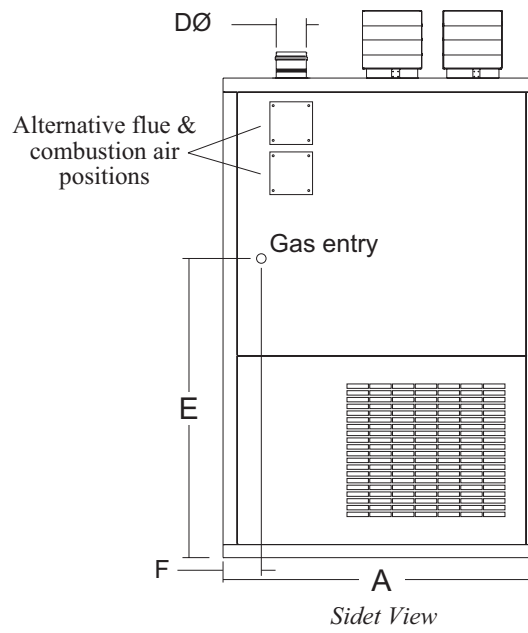
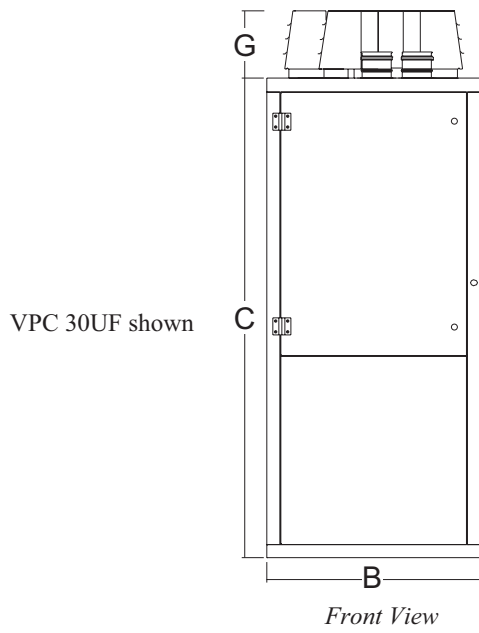

Table 1. Dimensions

Unit	A	B	C	D	E	F	G	Side Duct Spigot	Top Duct Spigot
VPC 30	1108	750	1676	100	1046	189	238	658(h) x 658(w)	648(h) x 658(l)
VPC 52			2132			132			
VPC 80	1412		286	658(h) x 960(w)		648(h) x 960(l)			
VPC 110	1767		2043	130	1049	134	340	658(h) x 1315(w)	648(h) x 1315(l)
VPC 130			2209						

Table 2 - Specifications

MODEL	HIGH FIRE		LOW FIRE		AIR VOLUME	FAN MOTOR	Available static pressure @ Std. Airflow	NOISE LEVEL	WEIGHT c/w Heads
	INPUT (Nett)	OUTPUT	INPUT (Nett)	OUTPUT					
	kW		kW						
VPC 30	32.6	30.0	18.0	15.7	0.8664	0.370	150	60.0	178
VPC 52	56.5	52.0	30.4	26.1	1.5884	0.55	200	68.0	248
VPC 80	87.0	80.0	42.0	36.8	2.3372	1.8	225	76.0	305
VPC 110	119.5	110.0	61.5	53.3	2.9568	2 x 0.55	150	72.0	362
VPC 130	141.3	130.0	78.1	69.0	3.6288	2 x 1.10	200	74.0	410

Table 3.1

Injector Sizes & Burner Pressures Natural Gas - Group H - G20 Net CV (Hi) = 34.02MJ/m³

Inlet Pressure 20mb	INJECTORS			High Fire		Low Fire	
				Burner Pressure	Gas Rate	Burner Pressure	Gas Rate
MODEL	No.	Size mm	Marked	mbar	m³/h	mbar	m³/h
VPC 30	6	1.94	194	13.8	3.45	4.6	2.02
VPC 52	12	1.94	194	10.4	5.98	3.0	3.22
VPC 80	12	2.54	254	9.0	9.19	2.1	4.44
VPC 110	10	3.00	300	11.5	12.64	3.2	6.50
VPC 130	12	3.00	300	11.8	15.52	3.6	8.26

Inlet pressure
20mbar

Table 3.2

Injector Sizes & Burner Pressures Propane - G31 Net CV (Hi) = 88.00MJ/m³

Inlet Pressure 20mb	INJECTORS			High Fire		Low Fire	
				Burner Pressure	Gas Rate	Burner Pressure	Gas Rate
MODEL	No.	Size mm	Marked	mbar	m³/h	mbar	m³/h
VPC 30	6	1.36	136	21.7	1.33	7.0	0.74
VPC 52	12	1.25	125	27.0	2.31	8.0	1.24
VPC 80	12	1.55	155	24.1	3.55	6.0	1.72
VPC 110	10	1.94	194	26.5	4.89	7.0	2.51
VPC 130	12	1.94	194	25.0	5.78	7.9	3.19

Inlet pressure
37mbar

Table 4

Electrical Loadings 1ph

MODEL	ELECTRICAL SUPPLY	POWER INPUT (kW)	NOMINAL MOTOR R.P.M.	PLATE AMPS (A)	START AMPS (A)	RUN AMPS (A)
VPC 30	230V 1N	0.80	900	3.6	7.4	3.3
VPC 52	230V 1N	1.10	900	5.8	8.7	5.4
VPC 80	230V 1N	3.0	950	13.6	32.8	15.0
VPC 110	400V 3N	2.37	1400 + 900	5.8 + 3.0	18.5	10.3
VPC 130	400V 3N	3.145	750 x 2	4.7 x 2	22.0	7.8

3. General Requirements

3.1 Related Documents

The installation of the air heater(s) must be in accordance with the rules in force and the relevant requirements of the Gas Safety Regulations, Building Regulations and the I.E.E. Regulations for Electrical Installations.

It should also be in accordance with any relevant requirements of the local gas region, local authority and fire authority and the relevant recommendations of the following documents.

Institution of Gas Engineers & Managers

IGE/UP/1 (Ed.2) Strength and tightness testing and purging of industrial and commercial gas installations.

IGE/UP/1A Soundness testing and direct purging of small low pressure industrial and commercial gas installations.

IGE/UP/2 Gas installation pipework, boosters and compressors on industrial and commercial premises.

IGE/UP/10 Installation gas appliances in industrial and commercial premises.

British Standards Code of Practice

BS 5588 Fire precautions in the design and construction of buildings.

Part 2 : 1985 Code of Practice for Shops

Part 3 : 1983 Code of Practice for Office Buildings

BS 6230: 1991 Installation of Gas Fired Forced Convection Air Heaters for Commercial and Industrial Space Heating.

Those appliances having a gross input rating not exceeding 60kW viz. VPC30, and installed so as to take their combustion air from within the building must be installed in accordance with the relevant recommendations of the following document.

BS 5440 Flues and Air Supply for gas appliances of rated input not exceeding 60kW (1st and 2nd family gases), Part 2 - Air Supply

3.2 Location

The location chosen for the air heater must permit:
- the provision of a satisfactory flue system and an adequate air supply.

- adequate space for servicing and air circulation around the air heater.

The heater(s) must not be installed in conditions for which it is not specifically designed e.g. where the atmosphere is corrosive or salty. Standard units are not suitable for outdoor location. Where the location of the air heater is such that it might suffer external mechanical damage e.g. from overhead cranes, fork lift trucks, it must be suitably protected.

VPC units are designed to operate within an ambient temperature range of -10 to 25°C.

3.3 Gas Supply

3.3.1 Service Pipes

The local gas undertaking should be consulted at the installation planning stage in order to establish the availability of an adequate supply of gas. An existing service pipe must not be used without prior consultation with the local gas undertaking.

3.3.2 Meters

A gas meter is connected to the service pipe by the local gas undertaking or a local gas undertaking contractor. An existing meter should be checked, preferably by the gas undertaking, to ensure that the meter is adequate to deal with the total rate of gas supply required.

3.3.3. Installation Pipes

Installation pipes should be fitted in accordance with IGE/UP/2. Pipework from the meter to the air heater must be

of adequate size. Do not use pipes of a smaller size than the inlet gas connection of the heater. The complete installation must be tested for soundness as described in the above Code.

3.3.4. Boosted Supplies

Where it is necessary to employ a gas pressure booster the controls must include a low pressure cut off switch at the booster inlet. The local gas undertaking must be consulted before a gas pressure booster is fitted.

3.4 Flue System

VPC units must be used with a closed flue system and have an internal exhaust fan, mounted downstream of the heat exchanger, to both assist the evacuation of the products of combustion and to draw in air for combustion.

The flue should terminate in a freely exposed position and must be so situated as to prevent the products of combustion entering any opening in a building in such concentration as to be prejudicial to health or a nuisance.

3.5 Combustion Air Supply

Where VPC units are to be installed within the space being heated and take the air from combustion from that space then for buildings having a design air change rate of less than 0.5/h, and the heated space has a volume less than 4.7 m³/kW of total rated heat input grilles shall be provided at low level as follows:-

- (1) for heaters of heat input less than 60 kW, the total minimum free area shall not be less than 4.5 cm² per kilowatt of rated heat input.
- (2) for heaters of heat input 60 kW or more, the total minimum free area shall not be less than 270cm² plus 2.25 cm² per kilowatt in excess of 60 kW rated heat input.

All air vents should have negligible resistance and must not be sited in any position where they are likely to be easily blocked or flooded or in any position adjacent to an extraction system which is carrying flammable vapour.

Grilles or louvres should be so designed that high velocity air streams do not occur within the plant room.

The basic minimum effective area requirements of the air vents are as follows:

- (a) Low Level (inlet)
 - (1) for heaters of total rated heat input less than 60kW: 9cm² per kilowatt of rated heat input.
 - (2) for heaters of total rated heat input 60kW or more: 540 cm² plus 4.5 cm² per kilowatt in excess of 60kW total rated input.
- (b) High Level (outlet)
 - (1) for heaters of total rated heat input less than 60kW: 4.5cm² per kilowatt of rated heat input.
 - (2) for heaters of total rated heat input 60kW or more: 270 cm² plus 2.25 cm² per kilowatt in excess of 60kW total rated input.

3.6 Air Distribution System

VPC units used in buildings having a low heat loss i.e. where single units are required to cover a large floor area, and in buildings with high roof or ceiling heights Calecon thermal economiser units should be fitted to ensure even heat distribution and minimise stratification.

Care should be taken to avoid impeding the air throw with racking, partitions, plant or machinery etc.

Care must be taken to ensure that return-air intakes are kept clear of sources of smells and fumes, and where there is any possibility of pollution of the air by dust, shavings etc., precautions must be taken to prevent contamination. If necessary suitable barrier rails should be provided to prevent any combustible material being placed within 900mm of the warm air outlets.

3.7 Electrical Supply

Wiring external to the air heater must be installed in accordance with the I.E.E. Regulations for Electrical Installations and any local regulations which apply. Wiring should be completed in flexible conduit.

All standard heaters are supplied by 230V - 1N, 50Hz or 400V - 3N, 50Hz depending on the size. The method of connection to the main electricity supply must:-

- facilitate the complete electrical isolation of the unit(s)
- be in a readily accessible position adjacent to the unit(s)
- serve only the unit(s)
- have a contact separation of at least 3mm in all poles. See the accompanying wiring diagram for the heater electrical connections.

4. Installation of Air Heater(s)

4.1 General

Before installation, check that the local distribution conditions, nature of gas and pressure, and adjustment of the appliance are compatible.

The air heater must be installed in accordance with the rules in force and the relevant requirements of any fire regulations or insurance company's requirements appertaining to the area in which the heater is located, particularly where special risks are involved such as areas where petrol vehicles are housed, where cellulose spraying is carried out, in wood working departments etc.

The following minimum clearances for installation and servicing must be observed.

RHS Clearance (looking at front of heater)	0.5m
LHS Clearance (looking at front of heater)	0.5m
Top of the heater to ceiling	1.0m
Rear of heater to nearest wall	0.5m
Front of heater to nearest wall	1.0m

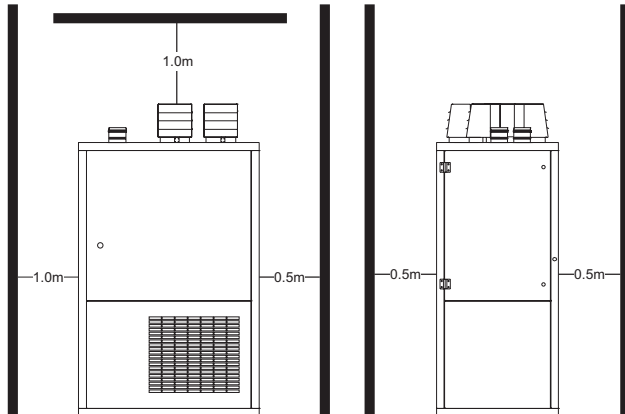

Fig 1 Minimum clearance distances

Any combustible material adjacent to the air heater and the flue system must be so placed or shielded as to ensure that its temperature does not exceed 65 °C.

IMPORTANT:

1. Heaters shall not be installed in:-
 - a) Those parts of spaces within buildings that have been classified as hazardous areas as defined in BS 5345 : Part 2.
 - b) Where there is a foreseeable risk of flammable particles or gases or corrosion inducing gases or vapours being drawn into either the heated air stream or the air for combustion.
 - c) In areas subjected to significant negative pressures due to extract systems.

4.2 Fitting the Air Heater

If necessary consideration should be given to mounting the heater on resilient pads, or equivalent, to minimise transfer of noise and vibration to the structure of the building. Floor mounted heaters must be installed on a level noncombustible surface.

Heaters mounted at high level must be supported on a purpose designed platform or framework that is suspended from vertical drop rods, chains or straps or mounted on specifically designed cantilever brackets from a non-combustible wall. The method of installation support must be capable of adequately supporting the weight of the unit (*See Table 2, Page 3*) and any ancillary equipment. Before installing the heater the existing structure must be inspected to ensure it is suitable. All supports should be protected against the effects of rust or corrosion. Any combustible material adjacent to the air heater and the flue system must be so placed or shielded as to ensure that its temperature does not exceed 65 °C.

If the method of mounting allows for any movement of the heater it is essential that all gas, duct, and electrical connections to the heater are made with flexible connections to maintain continuity of connection.

4.3 Flue/Combustion Air Duct System

All models are supplied as standard with a top flue outlet and combustion air inlet.

4.3.1.1. Conversion to Side Flue Outlet

1. Remove the two blanking plates from the flue /combustion air openings at the side of the unit.
2. Disconnect the flexible pipe from the exhaust spigot.
3. Remove the four screws securing the exhaust spigot and reposition the spigot to the side of the heater using the top position. Refit the flexible pipe.
4. Remove the four screws securing the combustion air spigot and reposition spigot to the side of the heater.
5. Refit the blanking plates to cover the holes in the top of the heater.

4.3.1.2 Internal Combustion Air

1. If ducted combustion air is not required (*see Section 3.5*) fit the mesh inlet plate (supplied loose) behind the unused combustion air inlet hole.

4.3.2. General Requirements

See Figures 2a to 3b for the different types of flue installation. In all cases the flue outlet socket must be connected via the provided flue system to outside air. The maximum permitted length of flue system is 6m, or 12m if the flue outlet only is used. If an offset is required two sets of 45° bends may be used each set being equivalent to 0.5m of flue length. The minimum flue length (end of flue terminal to side or top of heater) shall not be less than 1.3m.

All outer joints must be finished with the provided locking bands. A smear of silicon grease to the inside of sockets will assist in fitting components together. All flue and combustion air ducts must be supported independently of the air heater. The flue or flue/combustion air terminal must not be installed so as to be less than:

- 300mm below an opening e.g. window, air brick etc.
- 200mm below eaves or gutter.
- 300mm from an internal or external corner.
- 1200mm from a surface facing the terminal.
- 1500mm vertically from another terminal on the same wall.
- 300mm horizontally from another terminal on the same wall.
- 2000mm from ground level.

4.3.3 Installation of Flue System

Note: A terminal guard, as supplied by Powrmatic Ltd, must be fitted to horizontal flue terminals.

4.3.3.1 Horizontal System - Side Outlet

1. Locate the position of the flue terminal, allowing for a slight gradient running down from the heater to the terminal of 2° - 3° and cut a hole in the building wall to suit.
2. Fit the flue terminal, securing via the wall plate and weather with silicon sealant or similar.
3. Fit the twin to concentric adaptor to the terminal section and extend the flue and combustion air ducts to the heater using straight lengths. Fit an adjustable length prior to the unit, to facilitate flue disconnection for servicing. Extend the adjustable lengths to make the final connection to the appropriate heater inlet/outlet spigots.
4. Ensure that internal silicon sealing rings are in place and that all tubes are pushed fully home. Secure concentric lengths with the locking bands provided.

4.3.3.2 Vertical System - Top Outlet

1. Locate the position of the flue terminal cut a hole in the roof to suit.
2. Fit the flashing and the flue terminal so that the lower edge of the outer case is over the top of the flashing. Weather with silicon sealant or equivalent.
Fit a condensate drain length into the flue socket on the heater and an equivalent straight length onto the combustion air socket.
3. Fit the twin to concentric adaptor to the terminal section and then extend down to the heater using straight lengths. Fit adjustable lengths as the final connection pieces, to facilitate flue disconnection for servicing. Extend the adjustable lengths to make the final connection but do not exceed the maximum extended length so as to maintain joint integrity. Extend the drainage offtake of the condensate drainage length to a suitable gully or drain.
4. Ensure that internal silicon sealing rings are in place and that all tubes are pushed fully home. Secure concentric lengths with the locking bands provided.

4.3.3.3 Internal Combustion Air Systems

1. Complete the run of flue sections from the terminal spigot to the flue outlet socket of the heater generally as described in 4.3.3.1 and 4.3.3.2, ensuring that the internal silicon sealing rings are in place.
2. Ensure that the mesh inlet plate has been fitted (see 4.3.1.2).

4.4 Gas Connection

To facilitate servicing a servicing valve and downstream union must be fitted at the inlet to the air heater. The gas supply to the air heater must be completed in solid pipe work and be adequately supported. Heaters suspended by drop rods, straps or chains must have a flexible connection as the final link between the gas supply pipe work and the heater. Sufficient slack must be left in the connection to take account of normal movement of the heater.

Warning

When completing the final gas connection to the heater do not place undue strain on the gas pipe work of the heater.

4.5 Electrical Connections

All units are fully prewired and only require final connections for the incoming mains supply and fitment of the MC100. The control is shipped inside the heater burner compartment. Pass the connection cable through the hole in the front door, fit the control onto the outside of the door and connect the cable to the pcb inside the heater. If a MC100 or Powrtrol are not being

used, complete the control circuit (230V) via a room thermostat, time clock etc.

All units must be earthed. The electrical supply must be run to a point adjacent to the heater and be suitably terminated to provide an isolation point that will prevent remote activation of the unit during servicing. Reference must be made to Table 4 (*Page 3*) to ascertain the electrical loading of the unit(s) being installed so that cables of adequate cross-sectional area are used for the electrical installation. The length of the conductors between the cord anchorage and the terminals must be such that the current carrying conductors become taut before the earth conductor if the cable or cord slips out of the cord anchorage. All external controls must be of an approved type. See the wiring diagram accompanying these instructions.

5. Air Distribution System

5.1 General

VPC heaters, if required, can be used with duct work either to more precisely define the point of air delivery, and /or provide ducted return air or ducted fresh air inlet. The system should be checked to ensure that the installation work has been carried out in accordance with the design requirements. Particular attention should be given to the correct arrangement of delivery ducts and registers, return air ducts and grills and general adequacy of return air paths.

Ensure that the total duct system resistance does not exceed the available air pressure of the equipment supplied refer to Table 2 (*Page 3*). If the duct system resistance is less than the available air pressure of the equipment supplied additional resistance must be introduced e.g. by adjustment of duct outlet nozzles and balancing of the duct system. Conversely if the duct system resistance is greater than the available air pressure of the heater supplied the system resistance must be reduced.

5.2 Room Thermostat Siting

If a separate room thermostat is used it should be fitted at a point which will be generally representative of the heated area as far as temperature is concerned. Draughty areas, areas subjected to direct heat e.g. from the sun, and areas where the air movement is relatively stagnant e.g. in recesses, are all positions to be avoided for siting the thermostat. The thermostat should be mounted about 1.5m from the floor. Any room thermostat, frost thermostat, time clock etc. must be suitable for switching 230V, 5A and must be of the 'snap action' type to minimise contact bounce.

For electrical connections of external controls see the accompanying wiring diagram.

Fig 2a Exhaust only system - horizontal

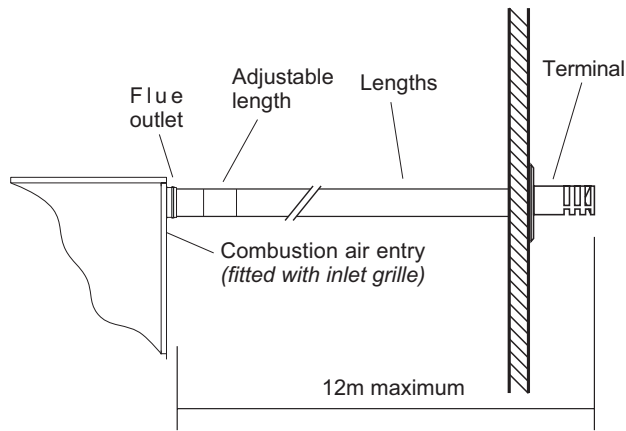

Fig 3a Individual system - horizontal

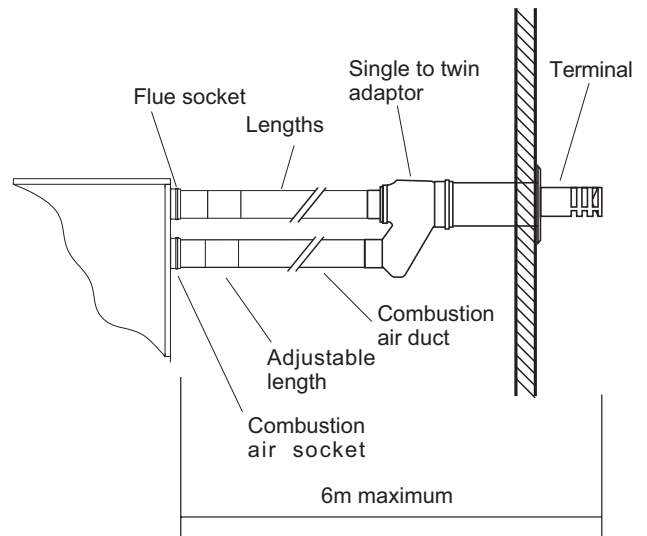

Fig 2b Exhaust only system - vertical

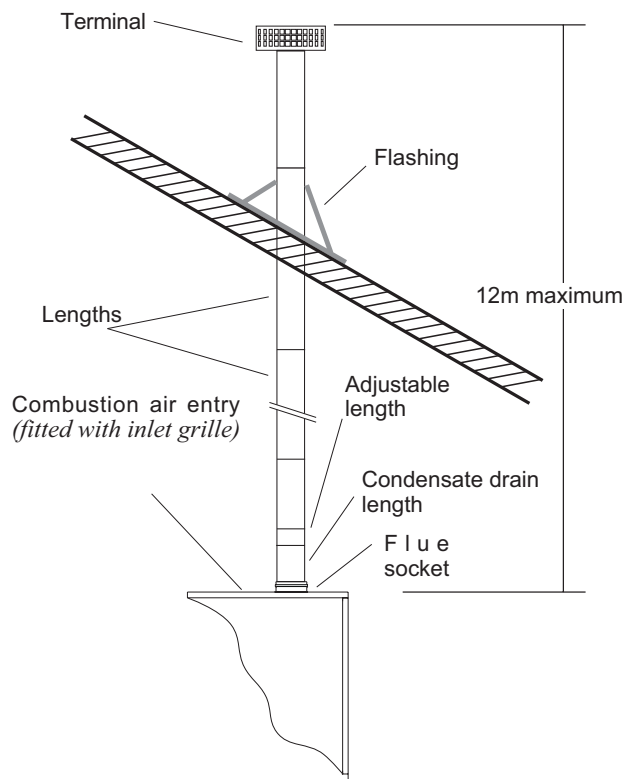
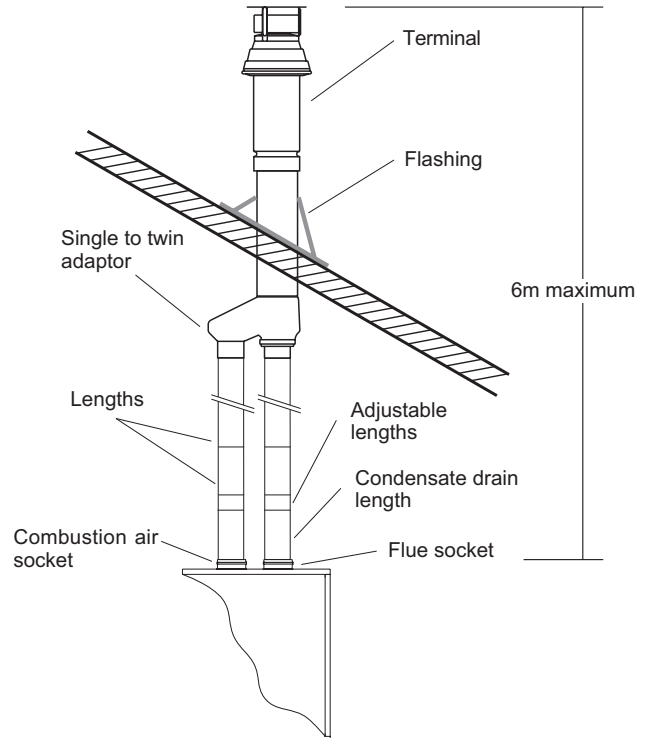

Fig 3b Individual system - vertical



Notes for all systems.

- i) Final overall length of adjustable disconnection piece must be between 360 - 415mm.
- ii) 45° offsets may be used if required. Each set is equivalent to 0.5m of flue length.
- iii) Where VPC heaters are used in clean environments it is permissible to take the combustion air directly from the heated space. The supplied mesh intake plate, must be fitted to the combustion air inlet on the rear of the heater.

6. Commissioning & Testing

6.1 Electrical Installation

Checks to ensure electrical safety must be carried out by a qualified person.

6.2 Gas Installation

The whole of the gas installation, including the meter, should be inspected and tested for soundness and purged in accordance with the recommendations of IGE/UP/1 (Edition 2) or IGE/UP/2A as appropriate.

6.3 First Start Sequence

Follow the sequence below before lighting the heater(s) for the first time.

- Ensure that the gas supply to the unit is turned OFF.
- Turn on the electrical supply to the heater and set up the controls in accordance with their instructions.
Note: The ignition sequence may start during this process but the heater will not light, as the gas supply is turned off, and the internal burner control will go to lockout. The lockout indicator on the external control will be illuminated.
- Ensure that the controls are not calling for heat i.e. the thermostat is at minimum or the clock control is set to an OFF period or the function switch is set to OFF.
- Check that all warm air delivery outlets are open.
- If necessary reset the internal control from lockout by pressing the reset button on the external control for 3 seconds.
- Check that the overheat reset button has not operated.
- Ensure that the Summer/Winter switch is in the Winter position.

- Turn ON the gas supply.

6.4 Lighting the Air Heater

NOTES:

- On initial lighting of the heater(s), it may take some time to purge the internal pipework of air.

IMPORTANT:

The internal pipework of the appliance has been tested for soundness before leaving the factory. After establishing the main burners test round the gas inlet connection using a leak detection fluid e.g. soap solution.

6.4.1 All Models

- Adjust the controls to call for heat and the ignition sequence will commence. After a delay of approximately 45 seconds the ignition spark will be generated and the main gas valves energized. The burners will then light followed in 15 - 30seconds by the main air fan.
- If the burners fail to light the control box will attempt two further ignition tries before going to lockout and the lockout light on the internal pcb will be illuminated. To restart the ignition sequence depress the reset button adjacent to the lockout light for at least 3 seconds.

3. SHUT OFF

Set the clock control to OFF or set the room thermostat to MIN.

6.5 Adjustments

6.5.1 Burner Gas Pressure

This is set for the required heat input before despatch. In the case of Hi/Lo and Modulating units both high and low pressures are set. Pressures should be checked in the following manner.

Fig 5 Controls Layout

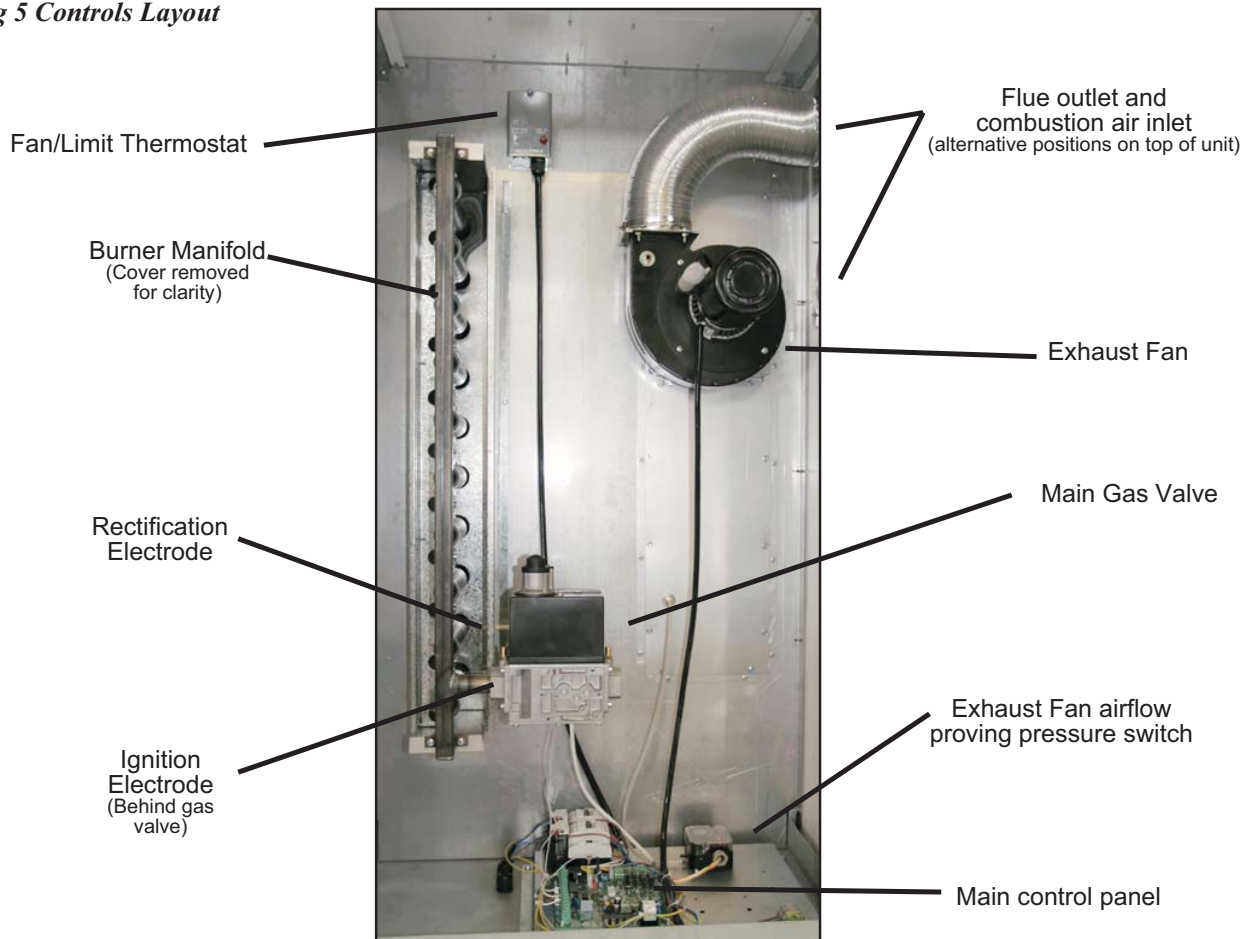

6.6.1.1 Standard Units

1. Set external controls to ensure that the main burner is off. Open the access door. Connect a pressure gauge to the burner pressure test point on the multifunctional control.

2. Set external controls so as to turn on the main burner. Compare the measured burner gas pressure to that stated on the data plate. If necessary adjust the burner gas pressure by turning the regulator screw anticlockwise to decrease the pressure, or clockwise to increase the pressure.

3. In addition it is advisable to check the gas rate using the gas meter dial pointer. Ensure that no other appliances supplied through the meter are in operation.

If required, after checking or setting the burner pressures, the CO₂ content in the flue gases can be checked by sampling in the first section of flue fitted to the flue outlet of the unit. Nominal CO₂ values are 8-9%.

5. Turn off the main burner as in 6.5.1. and disconnect the pressure gauge and replace the sealing screw. Turn on the main burner as above and test for gas soundness around pressure test joint using a leak detection fluid e.g. soap solution.

6.6.1.2 High/Lo and Modulating Heads

1. Set external controls to ensure that the main burner is off. Open the access panel. Connect a pressure gauge to the burner pressure test point on the multifunctional control.

2. Set external controls so as to turn on the main burner and maintain high fire. Compare the measured burner gas pressure to that stated on the data plate. In addition it is advisable to check the gas rate using the gas meter dial pointer. Ensure that no other appliances supplied through the meter are in operation.

3. Repeat 2 above with external controls set to maintain low fire.

4. If it is necessary to adjust the high pressure setting then proceed from step i). If it is only necessary to adjust the low fire pressure setting proceed from step vii).

- i) Set external controls to turn main burner OFF.
- ii) Pull back the clip D retaining the actuator coil to its mounting stem and remove the coil.
- iii) Set external controls to turn main burner ON.
- iv) Screw adjustment screw A fully clockwise.
- v) Release the M13 locknut E that secures the actuator stem B into the mfc governor pack and turn the actuator stem to set the HIGH FIRE pressure

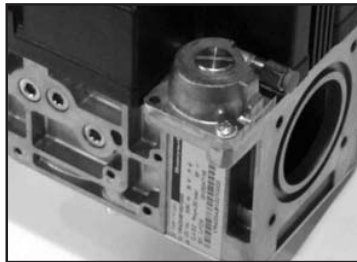

Fig 6
Governor adjustment screw under cover cap (Honeywell VR425AB1007)

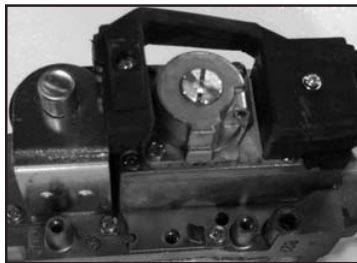
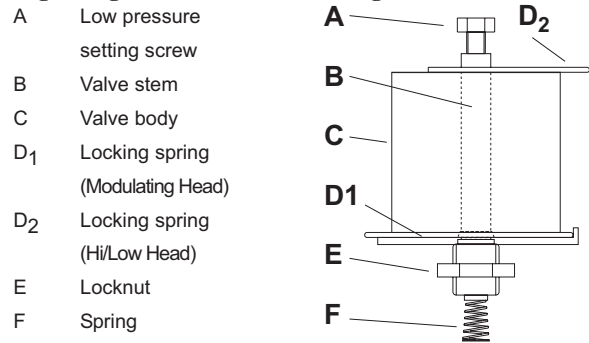

Fig 7
Governor adjustment screw under cover cap (Honeywell VR4605A B1027)

(clockwise to increase pressure).

- vi) Tighten the locknut without further turning the actuator stem.
- vii) Unscrew adjustment screw A to set the LOW FIRE pressure (anti clockwise to decrease pressure).
- viii) Set external controls to turn burner OFF and replace valve body C onto the valve stem ensuring that it clips into position.

Fig 8 High/Low and Modulating Head



5. Turn off the main burner as in 6.5.1 disconnect the pressure gauge and replace the sealing screw. Turn on the main burner as in 6.5.1 and test for gas soundness around pressure test joint using a leak detection fluid. Replace access panel.

6.6.2 Air Heater Controls

1. Close the gas service tap and ensure that the gas valve is heard to close within 1 second and that the lockout light is illuminated. Note that the heater will attempt three reignitions before going to lockout. Open the gas service tap and reset the unit from lockout.

2. Check that the room thermostat and all automatic controls are operating satisfactorily.

6.7 Handing over the Air Heater

Hand the Users Instructions to the user or purchaser for retention and instruct in the efficient and safe operation of the air heater and associated controls.

Adjust the automatic controls to those values required by the User.

Finally, advise the user or purchaser that, for continued efficient and safe operation of the air heater, it is important that servicing is carried out annually.

In the event that the premises are not yet occupied turn off the gas and electricity supplies and leave instructional literature adjacent to gas meter.

7. Servicing

WARNING: Always switch off and disconnect electricity supply and close the gas service valve before carrying out any servicing work or replacement of failed components.

NOTE:

If a suspended air heater is to be serviced do not lean ladders against the heater. Ensure that an access tower or equivalent is used.

7.1 General

Full maintenance should be undertaken not less than once per year by a qualified person. After any servicing work has been complete or any component replaced the air heater(s) must be fully commissioned and tested for soundness as described in Section 6.

7.2 Main Burner Assembly Removal

1. Ensure that the gas service valve is turned OFF and then unscrew the union nut situated immediately down stream of it.
2. Disconnect the spark and rectification leads from the pcb and remove the electrical plug connections from the top of the gas control valve assembly.
3. If required remove the manifold by first removing the front heat shield and then removing the four screws securing the manifold to the burner assembly.
4. Remove the two screws that secure the top of the burner assembly to the bulkhead and lift out burner assembly
5. Using a stiff brush, not a wire brush, brush the burners to

dislodge accumulated deposits. Inspect the burners both internally and externally to ensure that they are clean. Examine the injectors and if damaged or deteriorated, replace with new ones of the correct size and marking. If deemed necessary, clean the injectors. Do not broach out with wire.

6. Reassemble the injectors, manifold and burners in reverse order to that above.

7.3 Ignition and Rectification Electrodes

1. Inspect the electrodes, making sure that they are in a sound and clean condition. In particular check that the ignition electrode is clean and undamaged. Check that the spark gap is 2.5mm.

Fig 9 Ignition Electrode Spark Gap

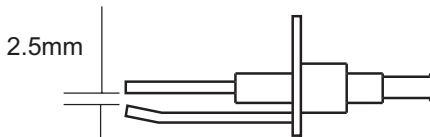

7.4 Heat Exchanger

Whilst the main burner assemblies are removed from the unit check that the primary sections that the burners fire into are clean.

7.5 Main Fan Assembly

1. Inspect the fan blades to see that they are not damaged and that there is no excessive build up of deposits that could give rise to an imbalance.

7.6 Replacement of Faulty Components

7.6.1 Multifunctional Control

1. Remove the electrical plug connections from the top of the gas control valve assembly
2. Release the flanged connections at the inlet and outlet of the multifunctional control and remove the multifunctional control.
3. Reconnect the new valve in the reverse order to that above ensuring that the valve is correctly orientated. Renew the sealing 'O' rings if necessary.

7.6.2 Burners

1. Remove the burner assembly as previously described in Section 7.2.
2. Remove the end plates of the burner assembly and the central burner support plate.
3. Exchange burners as required and reassemble components in reverse order.
4. Re-commission the appliance as described in Section 6.

7.6.3 Electrode Assemblies

1. Disconnect the electrode leads from the pcb terminal as appropriate.
2. Remove the screw securing the electrode assembly to the burner assembly side plate and withdraw the assembly.
3. Fit replacement and reassemble in reverse order. Check that the spark gap is 2.5mm (See Fig. 9).

7.6.4 Limit Thermostat - Honeywell L4064N

1. Release the single screw securing the fan and limit thermostat cover and remove cover by pulling forward.
2. Release wiring from clamp terminals by pushing a small screwdriver into the clamp release holes adjacent to the clamps.
3. Remove the 2 screws securing the thermostat to the heater panel and withdraw thermostat.
4. Reassemble new unit in reverse order referring to the heater wiring diagram to ensure correct wiring location.

Important: A replacement fan/limit thermostat will have a brass link between the bottom fan terminal and the bottom limit terminal (situated in the slot between the two terminals). This **MUST** be removed, by breaking the link off using a pair of thin nose pliers, before the replacement thermostat is installed.

NB. Ensure that the thermostats are set correctly before fitment

Limit Thermostat settings:-
 VPC 30, 52 90°C
 VPC 80 80°C
 VPC 110, 130 120°C

Fig 10 Thermostat Fan / Limit - Honeywell L4064N

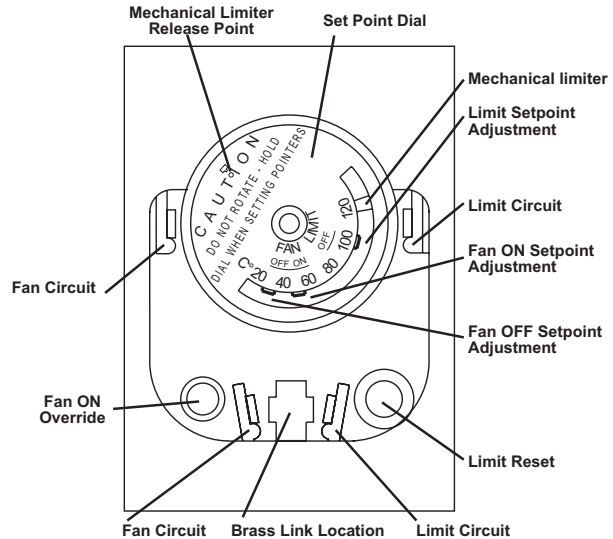

Note: The new L4064N may be supplied with the limit temperature mechanically limited to less than the setting required. To release the mechanical limit push a pointed object into the small hole at the top of the dial. At the same time prevent the dial from rotating and push the limit temperature adjuster around to the required setting.

7.6.5 Exhaust Fan

1. Disconnect the flexible pipe from the fan outlet.
2. Disconnect fan electrical connections from the terminals on the pcb.
3. Remove the fan and fan mounting plate from the bulkhead (4 screws).
4. Fit replacement exhaust fan, using new gaskets, and reassemble in reverse order.

7.6.6 Air Pressure Switch

1. Disconnect electrical connections.
2. Pull off the sensing tube from the air pressure switch.
3. Remove the screws fixing the air pressure switch and remove switch.
4. Fit replacement in reverse order refitting the sensing tube to the negative (- or L) tapping on the pressure switch.

7.6.7 Printed Circuit Board (pcb)

1. Disconnect all electrical connections.
2. Release the through hole clips securing the pcb and remove pcb.
3. Fit replacement in reverse order.

7.6.8 Main Air Fan(s)

1. Remove the lower side panels.
2. Disconnect the fan motor electrical lead from the controls.
3. Remove the screws securing the fan to the fan shroud and slide fan out. Note that the fans on the VPC110 and 135 are removed through the rear of the heater.
4. Fit replacement in reverse order.

8. Fault Finding Flow Chart

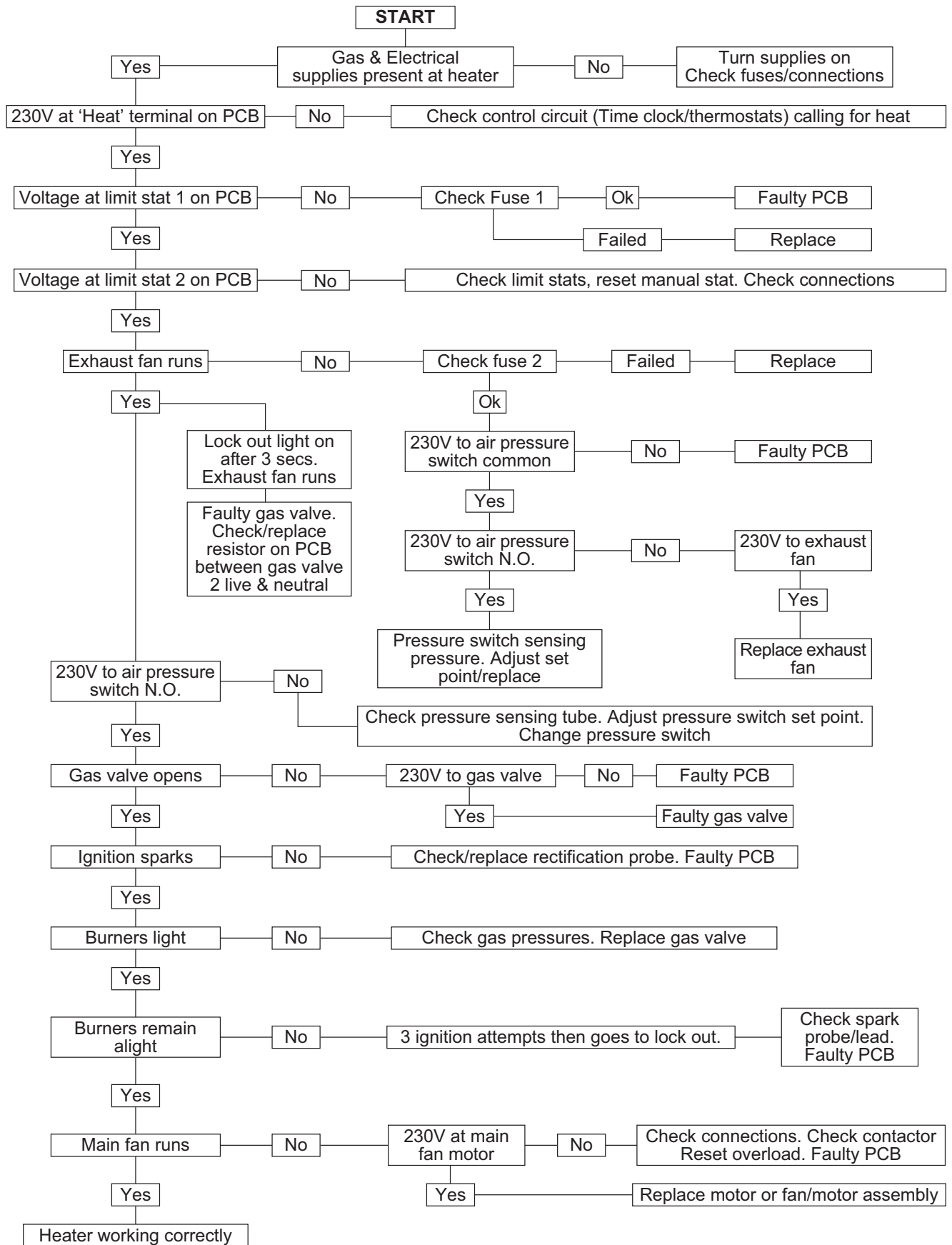











9. Wiring Diagram

See the wiring diagram supplied with the heater

10. Short List of Parts

Only originally specified parts may be fitted as service replacements.
Please refer to Powrmatic Ltd for any parts not detailed in the listing below.

ITEM		USAGE	PART #
MFC - Honeywell VR4605AB1027		30-80	145035204
MFC - Honeywell VR425AB1007		110, 130	141378715
Ignition Electrode (small)		30-80	142423002
Ignition Electrode (large)		110, 130	142423004
Rectification Electrode		30- 130	142423003
Burner - Bray P51 AB 19001		30-80	142400240
Burner - Bray P51 AB 19002		110, 130	142400241
Hi/Lo Governor Head - Anglo Nordic MD20003		30-130 -/HL	142466410
Modulating Governor Head - Anglo Nordic MD1003/MD		30-130 -/MOD	142466421
Amplifier board - Johnsons PIB-24		30-130 -/MOD	142400304
Exhaust Fan - Sifan WFFB 0223-006		30, 52	140210499
Exhaust Fan - Torin 077445		80-130	140201505
Dungs LGW 3A2		30, 52	146522174
Dungs LGW 10A2		80-130	142961107
Contactor - Danfoss CI 12		All	143000610
Main PCB		All	142403610/3

**HEATING DIVISION
Hort Bridge
Ilminster, Somerset TA19 9PS
Tel: 01460 53535 Fax: 01460 52341**

BSI Registered Firm

FM 414
Ind. & Comm. Air Heaters;
Air Moving Equipment;
Natural Smoke & Heat
Ventilators;
Powered Supply & Extract
Fans & Systems.

