

BRIDGEABLE POWER AMPLIFIER

AMPLIFICATEUR DE PUISSANCE  
PORTABLE

# OWNER'S MANUAL MODE D'EMPLOI

Thank you for purchasing the PIONEER GM-4000, and for your continued support of one of our products.

Please read this manual carefully before using the PIONEER GM-4000. For further details, refer to the manual.

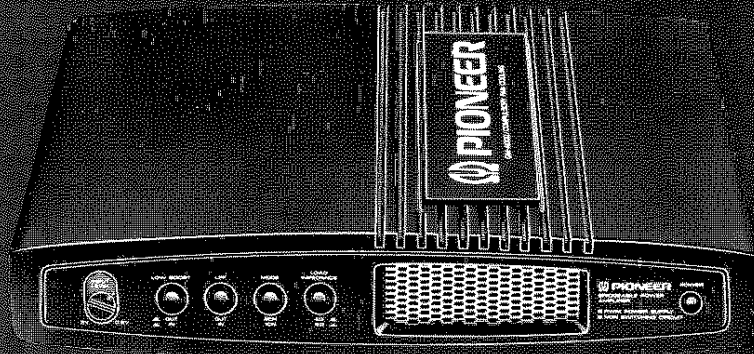

 **PIONEER**

*MASTER*  
**GM-4000**

- A DC/DC converter circuit with pulse width modulation (PWM), a three-stage, Darlington, single-ended push-pull (SEPP) circuit, and a non-switching circuit that eliminates switching distortion are used to give a high output power of 200 W + 200 W (stereo) or 400 W (mono) with a low harmonic distortion of 0.002% (at 1kHz and 40 W output).
- High-quality parts, such as gold-plated terminals, offering high conductivity, and audio capacitors, are used to assure high sound quality.
- Compulsory fan cooling, giving high cooling efficiency, is used to produce a new, compact design with no radiation fins.
- The bridgeable function allows switching between two channel mode (stereo) and single-channel mode (mono) by simply operating the mode select switch.
- The low boost switch enhances low-frequency sounds.
- The low-pass filter (LPF) switch allows the amplifier to be used as a power amplifier for sub-woofers.
- The auto input selector makes it easy to connect the amplifier to a car stereo with RCA pin jacks or one with DIN sockets.

### Important

The serial number of this device is located on the bottom of the unit. For your own security and convenience, be sure to record the serial number on the enclosed warranty card. Keep it handy for future reference.

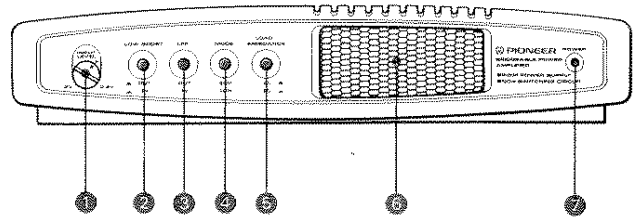

### ① Input Level Control

If the output is low even when the volume of the car stereo is turned up, turn this control clockwise. If there is distortion when the volume of the car stereo is turned up, turn this control counter-clockwise.

### ② Low Boost Switch

Press this switch to increase the volume of sounds in the low-frequency range if your car audio system does not reproduce enough bass sounds. This is effective when the amplifier is used to drive a sub-woofer.

- If there are no low-frequency sounds in the music you are listening to, or if you are using relatively small speakers, this switch may not make much difference.

## ③ Low Pass Filter (LPF) Switch

If this switch is pressed when this amplifier is to be used to drive a sub-woofer, only sounds in the low-frequency range will be output.

## ④ Mode Select Switch

Press this switch to use the amplifier as a mono amplifier.

- When the amplifier is used in this way, the speaker leads need to be connected accordingly. (See "Connecting Speaker Leads" on page 5.)

## ⑤ Load Impedance Select Switch

Press this switch when the impedance of the speaker or speakers connected to this amplifier is less than 4 ohms.

## ⑥ Compulsory Fan Cooling Air Inlet

When the volume increases or the inside temperature of the amplifier exceeds about 60°C, the internal cooling fan operates automatically to take air in through this air inlet and so cool the inside of the amplifier.

- There must be enough space in front of and behind the amplifier for the cooling to work properly.

## ⑦ Power Indicator

The power indicator lights when the power is switched on.

Connect the components correctly as shown in the diagram.

- Test-connect all components before securing them into place. Test-operate your entire car stereo system to ensure that there are no faulty wiring connections between this unit and the rest of your car stereo system.
- The input selector of this amplifier functions automatically. Therefore, the amplifier may be used with either a car stereo with RCA pin jacks or a Pioneer car stereo with DIN sockets. For information about connecting a stereo, see the section entitled "When combined with a car stereo with RCA pin jacks" or that entitled "When combined with a car stereo with DIN sockets".
- When two channels (stereo) are used, the speakers should have a minimum rating of 200 W or more. When a single channel (mono) is used, the speaker should have a minimum rating of 400 W or more. If a speaker whose rating is below that recommended is used, the speaker may be damaged. The impedance of the speakers should be between 2 and 8 ohms.
- For detailed information concerning connections between different components and this unit consult their respective instruction manuals and follow those recommendations precisely.
- When wiring connecting leads into place secure them with clippers and adhesive electrician's tape. Additionally, to prevent any damage to the insulative coating of the connecting leads, protect them with adhesive electrician's tape wherever they may come into contact with any sharp edges.
- Wire all connecting leads so that they stay well clear of high-temperature areas such as the heater exhaust port.
- To operate the amplifier and car stereo properly, install the continuous power supply lead (orange stripes) and the accessory power lead (red) correctly. If the leads are not installed correctly or are not connected at all, the amplifier and car stereo will not work.
- To use a car stereo with DIN sockets, use the optional component extension cable.

## General Amplifier Installation Guidelines for Power Supply Leads

1. Disconnect the negative (-) battery terminal first. This will avoid sparks if you short the battery with a wrench (negative terminals can not short out).
2. Route all leads and connections to proper locations.
3. Connect speaker leads, amplifier ground, amplifier power (orange stripes) to battery, ignition and trigger leads.
4. Connect RCA connectors from source unit to amplifier.
5. Carefully check all connections made to this point. The amplifier should be ready to operate as soon as the battery is reconnected.
6. Reconnect the negative battery terminal of the battery and test the installation.

## Connecting Leads (Supplied)

### Connecting the Continuous Power Supply Lead (Orange Stripes)

- Route the continuous power supply lead (orange stripes) from the engine compartment to the passenger compartment and connect it to the amplifier. To prevent short-circuits, make sure you connect all the other leads first, then connect the end of the continuous power supply lead to the positive (+) terminal of the battery.

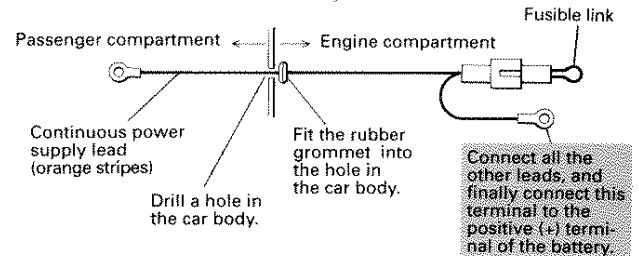

### CAUTION

- The fusible link is a safety device  
**DO NOT DEFEAT ITS PURPOSE**
- Should the fusible link blow
  - 1) Check the continuous power supply lead for possible cause of short circuit.
  - 2) **DO NOT** replace the fusible link with any other similar fuse available on the market or bypass the fusible link, as it may cause damage to the unit or to the car electrical system. Contact your dealer or the nearest authorized PIONEER Service Station immediately.  
Be sure to bring the continuous power supply lead when taking the unit for repair.

### Connecting Speaker Leads

- This amplifier has a mode select switch to select two-channel output (stereo) or one-channel output (mono). The speaker leads must be connected to suit the mode selected. Connect the speaker leads to the output terminals of the amplifier as shown in Fig. 1 and 2, paying attention to the polarities (+ and -), channels (right and left), and lead colors.

#### When two channels (stereo) are used

- Set the mode select switch to the 2CH position.

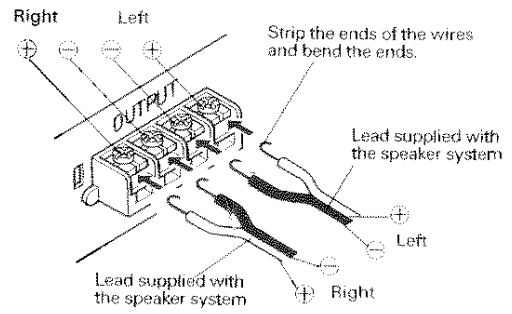

Fig. 1

#### When one channel (mono) is used

- Set the mode select switch to the 1CH position.

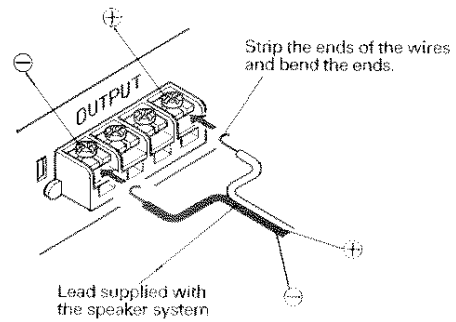

Fig.2

## Procedure for Connecting Speaker Leads

1. Strip the ends of the wires of both speaker leads supplied with the speaker system and bend the ends.
2. Pass the speaker leads through the large terminal cover. (Fig. 1)
3. Loosen the four output terminal screws at the rear of the amplifier in the middle.
4. According to the selected mode, hook the ends of the wires around the screws that were removed in step 3. Put the screws into the speaker output terminals and tighten then. (Fig. 2)
  - Be very careful that the wires do not stick out of the speaker output terminals and touch other wires.
5. Fit the large terminal cover. (Fig. 3)

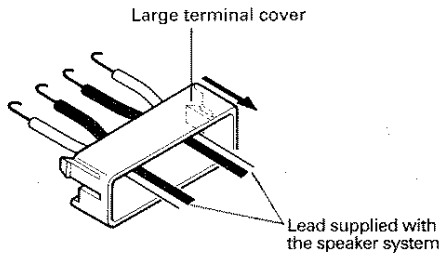

Fig. 1

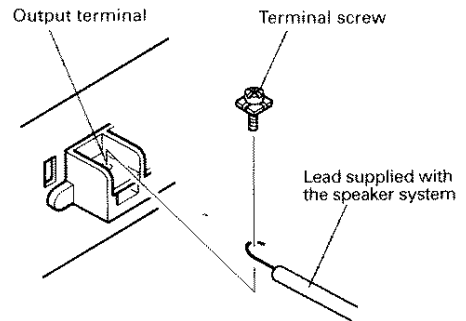

Fig. 2

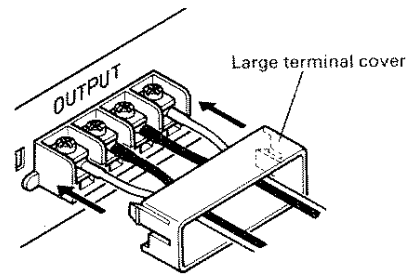

Fig. 3

### Procedure for Connecting Continuous Power Supply Lead (Orange Stripes) and Grounding Lead (Black)

1. Pass the continuous power supply lead (orange stripes) and the grounding lead (black) through the small terminal cover. (Fig. 4)
2. Remove the screws of the continuous power supply terminal and the grounding terminal at the rear of the amplifier on the left.
3. Replace the screws removed in step 2 in the terminals and tighten them. (Fig. 5)
4. Fit the small terminal cover. (Fig. 6)

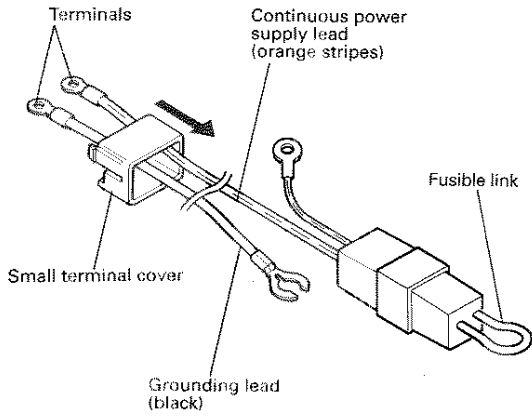

Fig. 4

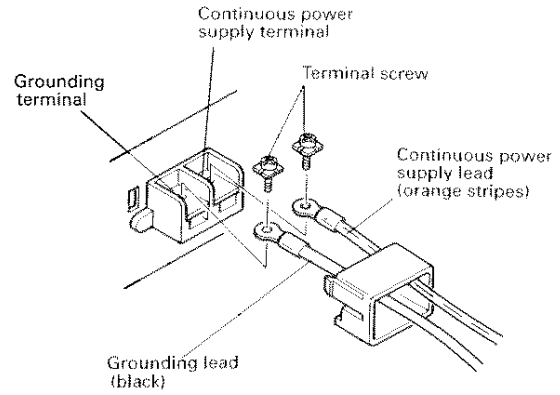

Fig. 5

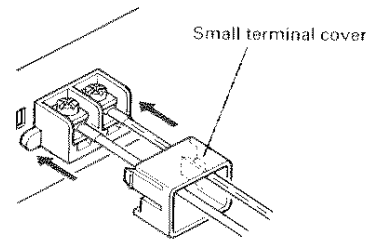
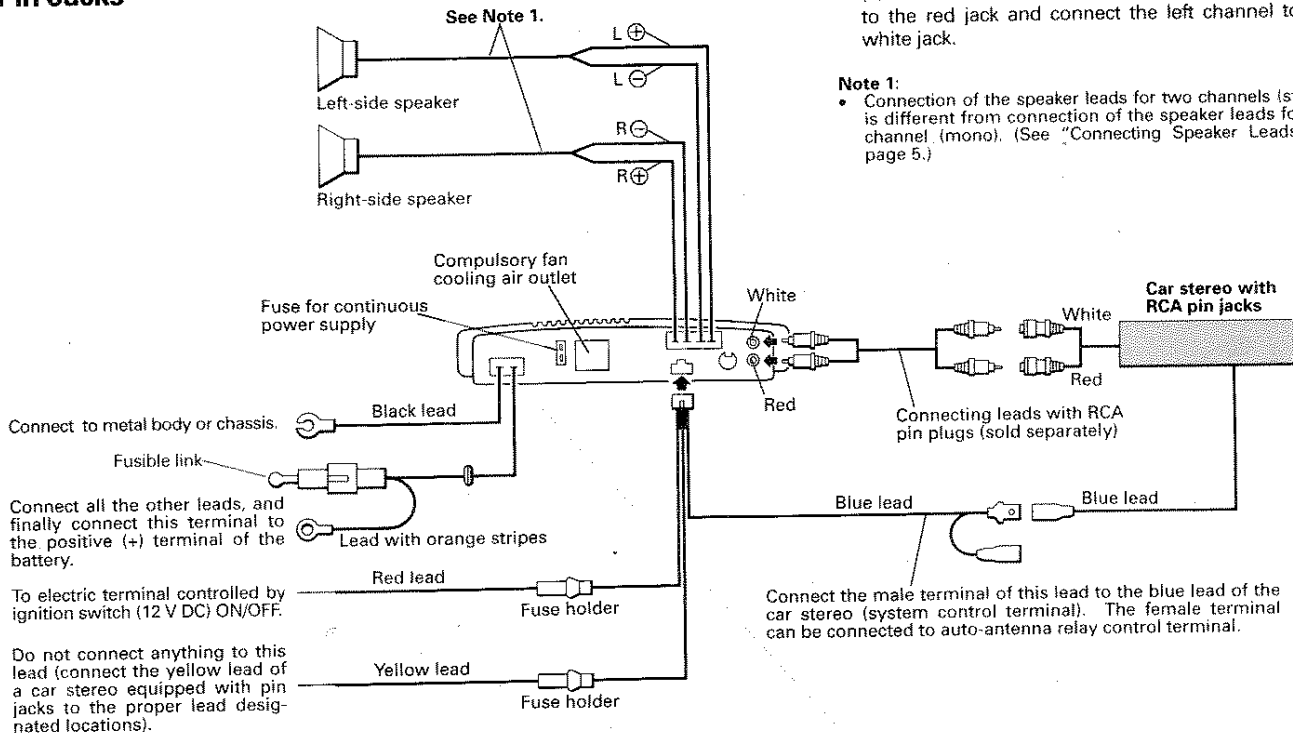

Fig. 6

## When Combined with a Car Stereo with RCA Pin Jacks



- When connecting connecting leads with RCA pin plugs (sold separately) to the auxiliary input jacks (red and white) of this unit, connect the right channel to the red jack and connect the left channel to the white jack.

### Note 1:

- Connection of the speaker leads for two channels (stereo) is different from connection of the speaker leads for one channel (mono). (See "Connecting Speaker Leads" on page 5.)



### When Combined with a Car Stereo with DIN Sockets

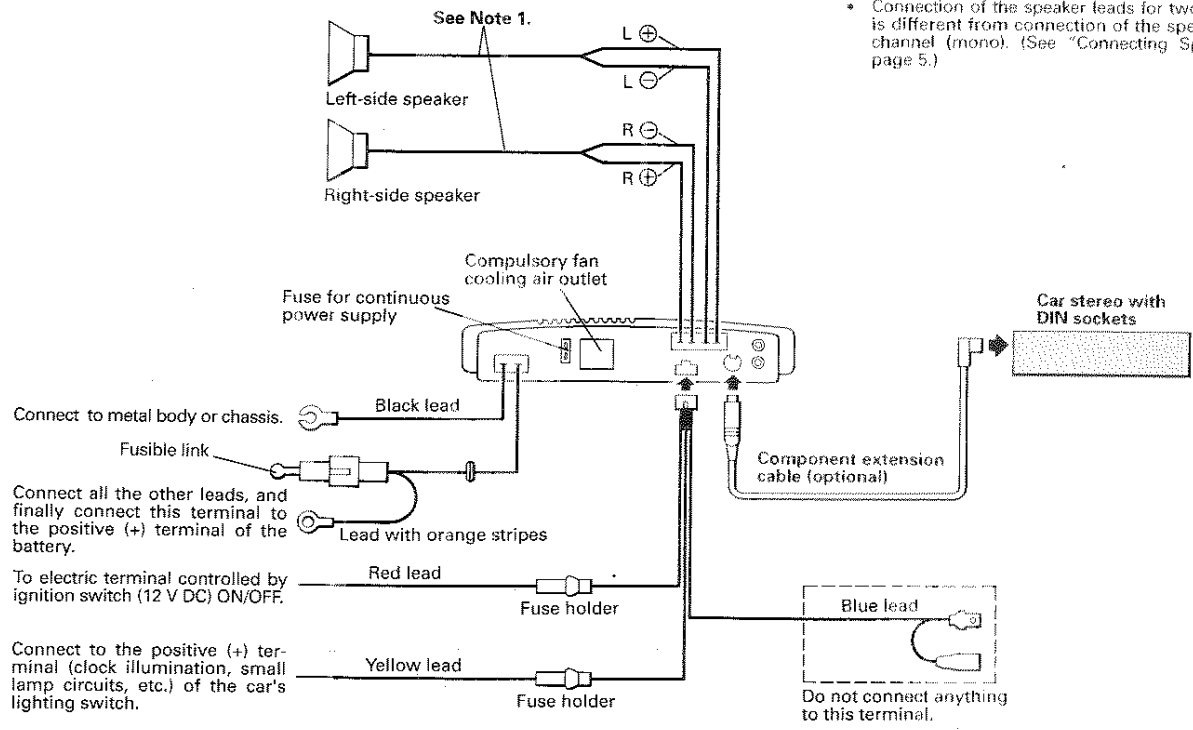

**Note 1:**

- Connection of the speaker leads for two channels (stereo) is different from connection of the speaker leads for one channel (mono). (See "Connecting Speaker Leads" on page 5.)

# Installation

- Be sure to use the parts supplied and install the unit securely. If parts other than those supplied (specified) are used, they may loosen or cause damage to internal parts.
- Be sure to install the unit in a place where the driver is not bothered and where there is no danger of passengers being injured in case of sudden stops.
- Be sure to consult your dealer before making any holes in the car.
- Cooling efficiency is degraded by making installations in hot places such as near the heater outlet, in the glove compartment and under floor mats that are tightly closed.
- To prevent short-circuits, be sure to disconnect the negative battery terminal before wiring the system up. When you finish the installation, be sure to make one more check to be sure everything is done correctly. Reinstall all car parts that were removed. Reconnect the negative battery lead.
- The unit has an internal compulsory cooling fan. It must not be installed near the heater outlet or under floor mats, as cooling will suffer. Never block the air inlet at the front of the unit or the air outlet at the rear.

## Example of Positions of Installation

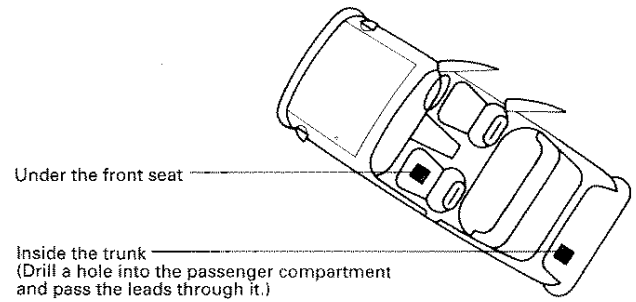

### ① Attaching the Brackets

Using the 5 × 6 mm screws supplied, attach the supplied pair of brackets to the bottom face of the unit as shown in Fig. 1. If the unit is installed directly on the car floor without using the supplied brackets it may overheat, causing the protection circuitry to operate.

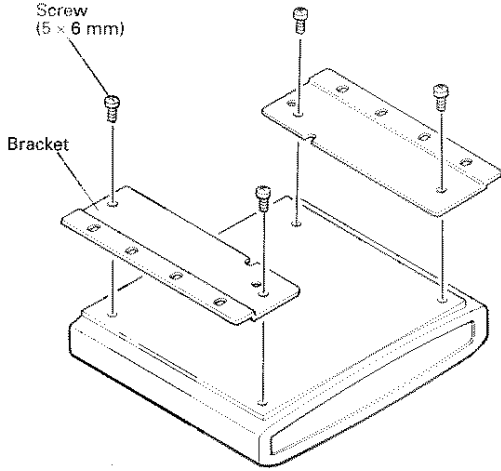

Fig. 1

### ② For Installation on the Floor Mat or Chassis

Install the unit on the floor mat or the chassis using the supplied tapping screws (5 × 16 mm). (Fig. 2)

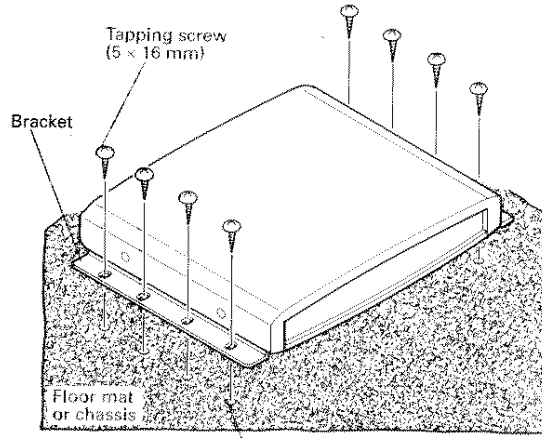

Fig. 2

## Care and Maintenance

- Enough care must be taken against battery overdischarge caused by long operation of the set at a high sound level when the engine is not running or is idling.
- The protection circuitry will operate instantaneously should any malfunctions occur, shutting off all sound. Under such circumstances, disconnect the power of the car stereo system, check the wiring for any possible causes and correct them before operating the stereo system again.
- When replacing the fuse, replace it with a fuse having the correct capacity.
- Dust the heat sinks occasionally so that they will not become clogged.

### In Case of Trouble

When the unit does not operate properly, contact your dealer or the nearest authorized PIONEER Service Station.

## Specifications

Power source	14.4 V DC (10.8–15.6 V allowable)
Grounding system	Negative type
Max. current consumption	30 A
Dimensions	290 (W) × 58 (H) × 230 (D) mm [11-3/8 (W) × 2-1/4 (H) × 9 (D) in.]
Weight	3.8 kg (8.4lbs.)(Leads for wiring not included)
Maximum power output	200 W × 2/400 W × 1
Continuous power output	120 W × 2/240 W × 1 (at 4 Ω, 1 kHz, 1% THD) 100 W × 2/200 W × 1 (at 4 Ω, 20–20,000 Hz, 0.008%/0.015% THD)
Load impedance	4 Ω (2–8 Ω allowable)
Frequency response	10–50,000 Hz (+0dB, -1dB)
Signal-to-noise ratio	104 dB (IHF-A network)
Distortion	0.002% (at 40 W, 1 kHz)
Low-pass filter cut-off frequency	80 Hz
Low-pass filter cut-off slope	12dB/octave
Low boost level	+6dB (100Hz)
Input level	.RCA: 0.2–2 V/7 kΩ DIN: 70–500mV/22kΩ

*These specifications were determined and are presented in accordance with specification standards established by the Ad Hoc Committee of Car Stereo Manufacturers.*

### Note:

Specifications and the design are subject to possible modification without notice due to improvements.

**PIONEER ELECTRONIC CORPORATION**

4-1, Meguro 1 chome, Meguro-ku, TOKYO, 153, JAPAN

**PIONEER ELECTRONICS (USA) INC.**

P.O. Box 1760, Long Beach, California 90801, U.S.A.

TEL: (800) 421-1404

**PIONEER ELECTRONIC (EUROPE) N.V.**

Keetberglaan 1, 2740 Beveren, Belgium

TEL: 03/775.28.08

**PIONEER ELECTRONICS AUSTRALIA PTY. LTD.**

178-184 Boundary Road, Braeside, Victoria 3195, Australia

TEL: (03) 580-9911

**PIONEER ELECTRONICS OF CANADA, INC.**

505 Cochrane Drive, Markham, Ontario L3R 6B8, Canada

代理店：東京エレクトロニクス株式会社  
〒153 東京都目黒区大田町1-4-1  
TEL: 03-421-1404

代理店：Pioneer Europe B.V.  
Keetberglaan 1, 2740 Beveren, Belgium  
TEL: 03-775-2808

Made in Japan  
Imported in Japan  
©1987 PIONEER

1987 PIONEER