

CD Stereo Radio Recorder

Service
Service
Service



AZ1140
AZ1141
AZ1142
AZ1143
AZ1145
all versions

Service Manual

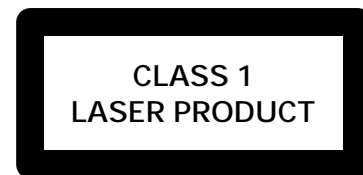

TABLE OF CONTENTS

	chapter		chapter
Handling chip components and safety	1 - 1	MAIN BOARD	
Technical Specification & Service Tools.....	2 - 1	circuit diagram	10 - 1
Service Measurement	2 - 2	layout diagram	10 - 2
Connections & Controls	3 - 1	RECORDER & BEAT CUT BOARD	
Instructions for use	3 - 2 to 3 - 6	circuit diagram	11 - 1
Disassembly Diagram	4 - 1	layout diagram	11 - 2
CD Service Test Program.....	4 - 2 to 4 - 3	CD MODULE	
Block Diagram	5 - 1	circuit diagram	12 - 2
Wiring Diagram	6 - 1	layout diagram	12 - 1
CONTROL BOARD		EXPLODED VIEWS DIAGRAM	
circuit diagram	7 - 1, 7 - 3	cabinet	13 - 1
layout diagram	7 - 2	tape deck	13 - 2
SWITCH & VOLUME BOARD		Mechanical partslist	13 - 2
layout diagram	8 - 1	Electrical partslist	14 - 1 to 14 - 4
TUNER BOARD			
circuit diagram	9 - 1		
layout diagram	9 - 2		

Safety regulations require that the set be restored to its original condition and that parts which are identical with those specified be used.

© Copyright 1995 Philips Consumer Electronics B.V. Eindhoven, The Netherlands
All rights reserved. No part of this publication may be reproduced, stored in a retrieval system or transmitted, in any form or by any means, electronic, mechanical, photocopying, or otherwise without the prior permission of Philips.



Published by SS 0024 Service Audio Printed in The Netherlands Copyright reserved Subject to modification © 3140 785 22260

PCS 104 409



PHILIPS

TECHNICAL SPECIFICATIONS

GENERAL

Mains voltage	-/00 : 230 V -/01/11/16 : 120/230 V -/05/10 : 240 V
Mains frequency	-/17 : 120 V -/00/05/10 : 50 Hz -/01/11/16 : 50 / 60 Hz -/17 : 60 Hz
Battery	mains : 9 V (R14 x 6) Remote : 3V (R03 x 2)
Power consumption	normal : 10 W standby : 2 W
Dimension (W x H x D)	: 290 x 152 x 253 mm
Weight	: 2.6 Kg

AMPLIFIER

Output power	mains : 2 x 1.6 W battery : 2 x 2 W
Speaker impedance	: 2 x 4 ohm
Frequency response	: 100 Hz - 8 kHz (± 3 dB)

TUNER - FM SECTION

Tuning range	: 87.5 - 108 MHz
IF frequency	: 10.7 MHz \pm 0.2 MHz
Sensitivity	: 16 dBf at 26dB S/N
Selectivity	: 55 dB at \pm 300kHz
IF rejection	: 85 dB
Image rejection	: 40 dB

TUNER - AM SECTION

Tuning range	MW : 531 - 1602 kHz -/17 : 520 - 1730 kHz LW : 153 - 279 kHz
IF frequency	: 450 kHz \pm 1 kHz
Sensitivity	MW : 64 dBu at 26dB S/N LW : 70 dBu at 26dB S/N
Selectivity	MW : 22dB LW : 29 dB
IF rejection ratio	MW : 70 dB LW : 70 dB
Image rejection ratio	MW : 32 dB LW : 35 dB

AUDIO CASSETTE RECORDER

Tape speed accuracy	: \pm 3%
Wow & flutter	: < 0.35 % JIS WTD
Fast wind/rewind C60	: < 120 sec.
Frequency response	P/B : 125 – 6.3 kHz
S/N ratio	: 45 dB

COMPACT DISC

Frequency response	: 100 Hz - 10 kHz
S/N ratio	: > 50 dB
Channel difference	1 kHz : < 3 dB
Channel crosstalk	1 kHz : > 26 dB
Laser wavelength	: 780 \pm 20nm
Laser light power	: < 0.3 mW

SERVICE TOOLS

Audio signal disc SBC 429.....	4822 397 30184
Playability test disc SBC 444.....	4822 397 30245
Test disc 5 (disc without errors) +	
Test disc 5A (disc with dropout errors, black spots and fingerprints)	
SBC 426/426A.....	4822 397 30096
Burn in test disc (65 min. 1kHz signal at -30 dB level without "pause").....	4822 397 30155
Universal test cassette Fe SBC 420.....	4822 397 30071

CONNECTIONS AND CONTROLS

TOP AND FRONT PANELS

- 1 **POWER slider** - selects the sound source for CD/TUNER/ TAPE off and also switches the set off
- 2 **VOL +, -** - adjusts the volume level
- 3 **BATT LOW** - indicates when battery power is running low
- 4 **DBB (Dynamic Bass Boost)** - enhances the bass
- 5 **OPEN • CLOSE** - opens/ closes the CD door
- 6 **CASSETTE RECORDER keys**
RECORD ● - starts recording
PLAY ◀ - starts playback
SEARCH ◀◀▶▶ - fast winds/rewinds the tape
STOP•OPEN ■▶ - stops the tape; - opens the cassette compartment
- 7 **PAUSE II** - interrupts recording or playback
- 8 **Remote sensor** - infrared sensor for the remote control
- 9 **1-3** - programmes and selects your favourite three radio stations
- 10 **PRESET ▲, ▼** - (down, up) selects preset tuner stations
- 11 **BAND** - selects waveband
- 12 **PLAY PAUSE ▶II** - starts /pauses CD playback
- 13 **CD MODE** - selects a different play mode e.g. SHUFFLE/ REPEAT CD tracks or programme in random /repeated order
- 14 **STOP ■** - stops CD playback or erase a CD programme; activates/ deactivates display demo mode.
- 15 **Cassette door**
- 16 **Display** - shows the status of the set
- 17 **SEARCH ◀◀▶▶**
Tuner: (down, up) tunes radio stations.
CD: - searches back and forward within a track; - skips to the beginning of a current track/ previous/ later track

PROGRAM -

- 18 **Tuner** - programmes preset radio stations; CD - programmes tracks and reviews the programme

BACK PANEL

- 18 **3.5 mm stereo headphone socket**
- 19 **Telescopic aerial** - improves FM reception
- 20 **BEAT CUT switch** - eliminates possible whistle tones during MW (AM) recordings
- 21 **AC Mains** - inlet for mains lead
- 22 **Battery compartment** - for six batteries, type **R-14, UM-2** or **C-cells**
- 23 **Voltage selector** (located inside the battery compartment. Some versions only) - select the correct local voltage 110/220 V before plugging in the set

REMOTE CONTROL

- 1 **VOLUME ▲, ▼** - adjusts volume level
- 2 **PRESET ▲, ▼** (up, down) - selects a preset radio station
- 3 **TUNING ◀◀ ▶▶** (down, up) - tunes to radio stations
- 4 **SHUFFLE** - to play CD tracks in random order
- 5 **REPEAT** - repeats a track/ CD programme/ entire CD
- 6 **▶II** - starts and pauses CD playback/ interrupts CD playback
- 7 **◀▶** - skips to the beginning of a current track/ previous/ later track
- 8 **STOP ■** - stops CD playback or erases a CD programme
- 9 **SEARCH ◀◀ ▶▶** - searches backwards or forwards within a track/CD

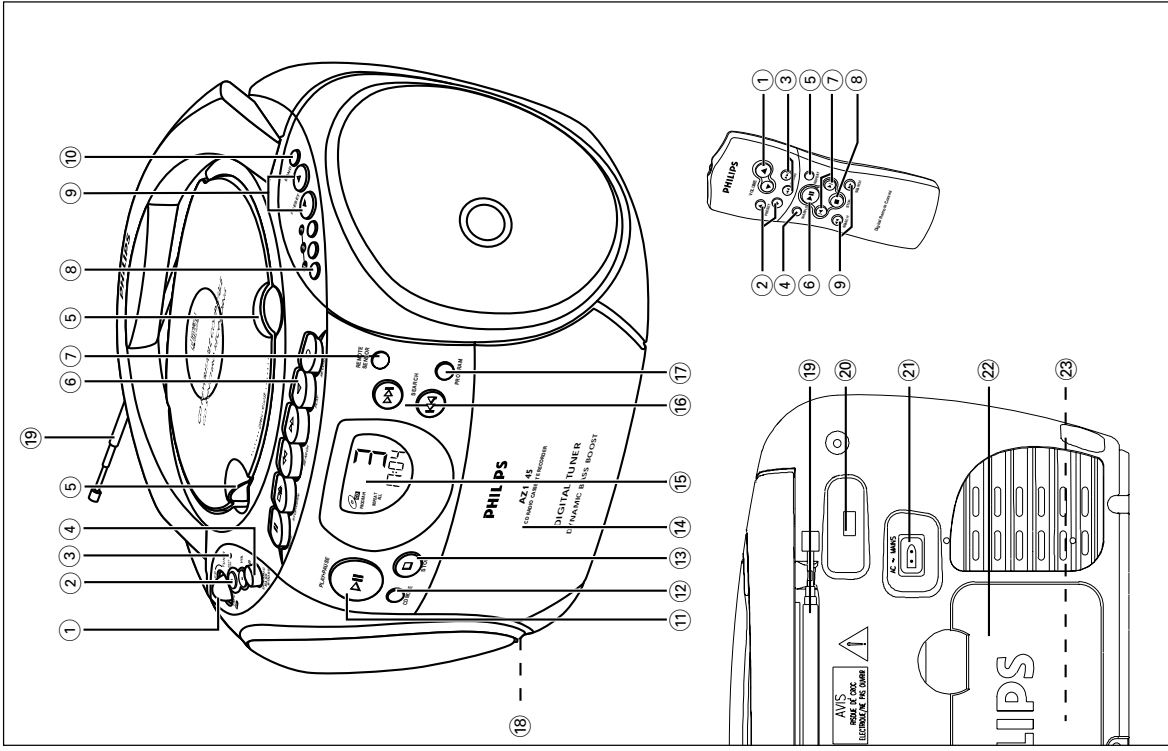

CAUTION
 Use of controls or adjustments or performance of procedures other than herein may result in hazardous radiation exposure or other unsafe operation.

INSTRUCTIONS FOR USE

Whenever convenient, use the mains supply if you want to conserve battery life. Make sure you remove the plug from the set and wall socket before inserting batteries.

BATTERIES (OPTIONAL)

1. Open the battery compartment and insert six batteries, type **R-14**, **UM-2** or **C-cells**, (preferably alkaline) with the correct polarity as indicated by the "+" and "-" symbols inside the compartment.

Remote control (supplied)

Open the battery compartment and insert two batteries, type **AAA**, **R03** or **UM4** (preferably alkaline).

2. Replace the compartment door, making sure the batteries are firmly and correctly in place. The set is now ready to operate.

- If **BATT LOW** lights up, battery power is running low.
 - The **BATT LOW** indicator eventually goes out if the batteries are too weak.

Incorrect use of batteries can cause electrolyte leakage and will corrode the compartment or cause the batteries to burst. Therefore:

- Do not mix battery types: e.g. alkaline with carbon zinc.
- Only use batteries of the same type for the set.
- When inserting new batteries, do not try to mix old batteries with the new ones.
- Remove the batteries if the set is not to be used for a long time.
- Batteries contain chemical substances, so they should be disposed of properly.

Using AC MAINS

1. Check if the mains voltage as shown on the type plate on the base of the set, corresponds to your local mains supply. If it does not, consult your dealer or service centre.
2. If your set is equipped with a voltage selector, adjust the selector so that it matches with the local mains supply.
3. Connect the mains lead to the wall socket and the set is now ready for use.
4. To disconnect the set from the mains supply completely, remove the plug from the wall socket.



Switching on and off

- Adjust the **POWER** slider to the desired sound source: **CD**, **TUNER** or **TAPE/OFF**.

- The set is switched off when the **POWER** slider is in the **TAPE/OFF** position and the keys on the tape deck are released.
- ™ The volume and tuner presets will be retained in the set's memory.

**Adjusting volume and sound**

1. Press the **VOL +/-** controls to increase or decrease **VOLUME** (or press **3** or **4** on the remote control).
2. Adjust the **DBB** control to select dynamic bass boost on or off.

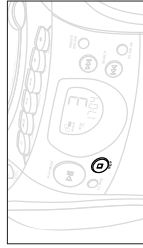
**PHILIPS demo mode**

1. On the set, press the **CD STOP 9** button for 5 seconds.
- ™ **PH.IL .IPS** scrolls across the display continuously.
2. To return to the current display you can either:
 - press any function button on the front panel. This interrupts the demo mode for 30 seconds;
 - press the **CD STOP 9** button for 5 seconds. **PH.IL .IPS** scrolls once before the demo mode is cancelled.

GENERAL INFORMATION**General maintenance**

- Do not expose the set, batteries, CDs or cassettes to humidity, rain, sand or excessive heat caused by heating equipment or direct sunlight.
- To clean the set, use a soft, slightly dampened chamois leather. Do not use any cleaning agents containing alcohol, ammonia, benzene or abrasives as these may harm the housing.

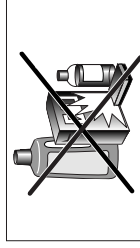
**Safety information**

- Place the set on a hard and flat surface so that the system does not tilt. Make sure there is adequate ventilation to prevent the system from overheating.
- The mechanical parts of the set contain self-lubricating bearings and must not be oiled or lubricated.

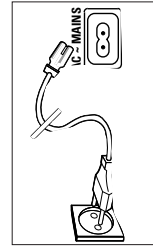
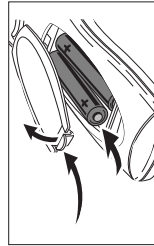
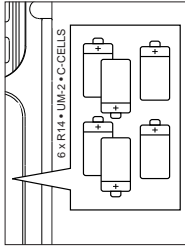
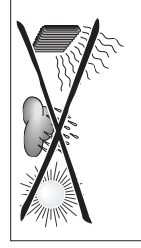

TUNING TO RADIO STATIONS

1. Select **TUNER** source.
 The **T** is displayed briefly and then the radio station frequency is shown.
2. Press **BAND** once or more to select your waveband.
3. Press **SEARCH** or **S** and release when the frequency in the display starts running.
 The tuner automatically tunes to a station of sufficient reception. Display shows **STEREO** during automatic tuning.
4. Repeat **step 3** if necessary until you find the desired station.
 • To tune to a weak station, press **SEARCH** or **S** briefly and repeatedly until you have found optimal reception.
5. Adjust the power slider to **TAPE/OFF** position to switch off the set.

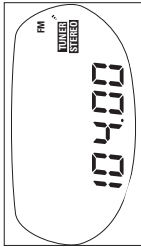
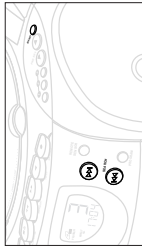

To improve radio reception

- For **FM**, pull out the telescopic aerial. Incline and turn the aerial. Reduce its length if the signal is too strong (very close to a transmitter).
- For **MW (AM)**, the set is provided with a built-in aerial so the telescopic aerial is not needed. Direct the aerial by turning the whole set.

Favourite station selection

- For your favourite 3 tuner stations, you can use the easy one-touch programming and selection **1**, **2** or **3** buttons.
1. Tune to your desired station (see **Tuning to radio stations**).
 2. To store your station, press **1**, **2** or **3** for 2 seconds or more.
 The display shows **PROGRAM** briefly, your favourite preset station number and the tuner frequency.



Programming radio stations

- You can store up to a total of 30 radio stations in the memory.
1. Tune to your desired station (see **Tuning to radio stations**).
 2. Press **PROGRAM** to activate programming.
 The display shows **PROGRAM** flashes.
 3. Press **PRESET 4** or **3** once or more to allocate a number from 1 to 30 to this station.
 4. Press **PROGRAM** again to confirm the setting.
 The display shows **PROGRAM** disappears, the preset number and the frequency of the preset station are shown.
 5. Repeat the above four steps to store other stations.
 You can overwrite a preset station by storing another frequency in its place.

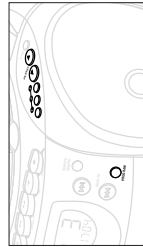

Tuning to preset stations

- Press **1**, **2** or **PRESET 4** or **3** until the desired preset station is displayed.

Changing tuning grid (some versions only)

In North and South America the frequency step between adjacent channels in the AM and FM band are **10 KHz** and **100 KHz** respectively. In the rest of the world this step is **9 KHz** and **50 KHz**. Usually the frequency step has been preset in the factory for your area.

1. Check that the set is in the **TAPE/OFF** position and switched off.
 2. To select 9KHz : press **CD MODE** and **PROGRAM** simultaneously. Release the controls only when you switch on the set.
 • To select 10KHz: press **CD MODE** and **SEARCH S** simultaneously. Release the controls only when you switch on the set.
 3. When tuning to radio stations, the display shows tuning in either steps of **9** or **10**.
- The **All** preset stations will be affected and you may need to reprogramme your presets.

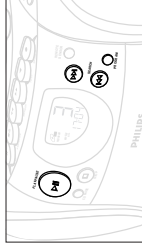

Playing a CD

1. Select **CD** source.
 The **CD** is displayed briefly.
 2. Lift the CD door open.
 Display: **CD** when you open the CD door.
 3. Insert a CD or CD-R(W) with the printed side facing up and close the CD door.
 The **CD** flashes as the CD player scans the contents of a CD. The total number of tracks and playing time are then shown.
 Display: **1:57** is shown if the CD-R(W) is blank or not finalised.
 4. Press **PLAY•PAUSE 2**; (on the remote control **2**;) to start playback.
 Display: Current track number and elapsed playing time of the track during CD playback.
 5. To pause playback press **PLAY•PAUSE 2** .
 Press **PLAY•PAUSE 2**; again to resume play.
 The display freezes and the elapsed playing time flashes when playback is paused.
 6. To stop CD playback, press **STOP 9**.
- Note: CD play will also stop when:
- the CD door is opened;
 - the CD has reached the end (unless you have selected **REPEAT** or **REPEAT ALL**);
 - you select another source: **TAPE / TUNER**.

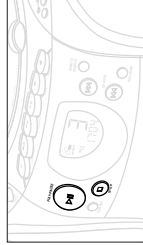

Selecting a different track

- Press **SEARCH** or **S** (on the remote control **i** or **™**) once or repeatedly until the desired track number appears in the display.
- If you have selected a track number shortly after loading a CD or in the **PAUSE** position, you will need to press **PLAY•PAUSE 2**; to start playback.

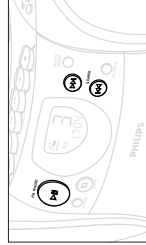

Finding a passage within a track

1. Press and hold down **SEARCH** or **S**.
™ The CD is played at high speed and low volume.
2. When you recognize the passage you want, release **SEARCH** or **S**.
– Normal playback continues.

Note: During a CD programme or if **SHUFFLE/ REPEAT** active, searching is only possible within a track.

Different play modes: SHUFFLE and REPEAT

You can select and change the various play modes before or during playback. The play modes can also be combined with **PROGRAM**.

SHUFFLE - tracks of the entire CD/ programme are played in random order

SHUFFLE and REPEAT ALL - to repeat the entire CD/ programme continuously in random order

REPEAT ALL - to repeat the entire CD/ programme continuously

REPEAT - to play the current track continuously

1. To select your play mode, press the **CD MODE** key (or **SHUFFLE** or **REPEAT** on the remote control) before or during playback until the display shows the desired function.

2. Press **PLAY•PAUSE 2**; to start playback if in the STOP position.

3. To return to normal playback, press the **CD MODE** key or the respective **SHUFFLE** or **REPEAT** key until the various **SHUFFLE** / **REPEAT** modes are no longer displayed.

– You can also press **STOP 9** to cancel your play mode.

Programming track numbers

Programme in the STOP position to select and store your CD tracks in the desired sequence. If you like, store any track more than once. Up to 20 tracks can be stored in the memory.

1. Use the **SEARCH** or **S** on the set (on the remote control i or ™), to select your desired track number.

2. Press **PROGRAM**.

™ Display: **PROGRAM** and the selected track number. *prog* appears briefly.

™ If you attempt to programme without first selecting a track number, *SET* is shown.

3. Repeat steps 1-2 to select and store all desired tracks.

™ **FULL** is displayed if you attempt to programme more than 20 tracks.

4. To start playback of your CD programme, press **PLAY•PAUSE 2**.

Reviewing the programme

In the STOP position, press and hold down **PROGRAM** for a while until the display shows all your stored track numbers in sequence.

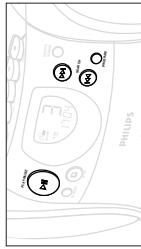
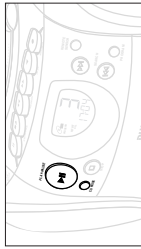

Erasing a programme

You can erase the programme by:

- pressing **STOP 9** once in the STOP position or twice during playback. The display shows 'prog' briefly.
- pressing the CD door open;
- switching to **TUNER/TAPE** source.

CD player and CD handling

- If the CD player cannot read CDs correctly, use a commonly available cleaning CD to clean the lens before taking the set to repair. Other cleaning methods may destroy the lens.
- The lens of the CD player should never be touched!
- Sudden changes in the surrounding temperature can cause condensation to cloud over on the lens of your CD player. Playing a CD is then not possible. Do not attempt to clean the lens but leave the set in a warm environment until the moisture evaporates.
- Always keep the CD compartment closed to avoid dust on the lens.
- To take a CD out of its box, press the centre spindle while lifting the CD. Always pick up the CD by the edge and return the CD to its box after use to avoid scratching and dust.
- To clean the CD, wipe in a straight line from the centre towards the edge using a soft, lint-free cloth. Do not use cleaning agents as they may damage the disc.
- Never write on a CD or attach any stickers to it.

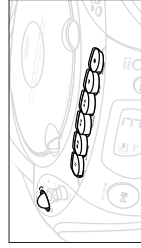
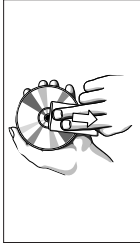
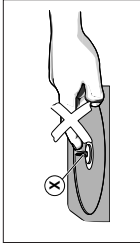

PLAYING A CASSETTE

1. Select **TAPE** source.
™ The display shows **TAPE** throughout tape operation.
2. Press **STOP•OPEN 9/** to open the cassette door.
3. Insert a recorded cassette and close the cassette door.
4. Press **PLAY 1** to start playback.
5. To interrupt playback, press **PAUSE**; To resume, press the key again.
8. By pressing **SEARCH 5** or **6** on the set, fast winding of the tape is possible in both directions.
9. To stop the tape, press **STOP•OPEN 9/**.
– The keys are automatically released at the end of the tape and the **TAPE** indication goes out, except if **PAUSE**; has been activated.

GENERAL INFORMATION ON RECORDING

- Recording is permissible insofar as copyright or other rights of third parties are not infringed.
- This deck is not suitable for recording on CHROME (IEC II) or METAL (IEC IV) type cassettes. For recording, use NORMAL type cassettes (IEC I) on which the tabs have not been broken.
- The best recording level is set automatically. Altering the **VOL** and **DBB** controls will not affect the recording in progress.
- At the very beginning and end of the tape, no recording will take place during the 7 seconds, when the leader tape passes the recorder heads.
- To protect a tape from accidental erasure, have the tape in front of you and break out the left tab.
- Recording on this side is no longer possible. To record over this side again, cover the tabs with a piece of adhesive tape.

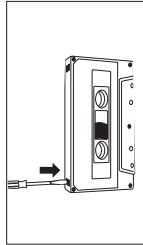

Recording from the radio

1. Tune to the desired radio station (See **TUNING TO RADIO STATIONS**).
2. Press **STOP•OPEN 9/** to open the cassette door.
3. Insert a suitable cassette into the cassette deck and close the cassette door.
4. Press **RECORD O** to start recording.
 - If you are recording from MW (AM) stations, adjust the **BEAT CUT** switch to eliminate possible whistle tones during recording.
5. For brief interruptions, press **PAUSE ;**. To resume recording, press **PAUSE ;** again.
6. To stop recording, press **STOP•OPEN 9/**.

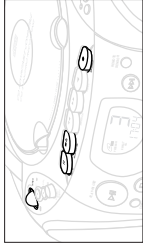

SYNCHRO START CD RECORDING

1. Select **CD** source.
2. Insert a CD and if desired, programme track numbers.
3. Press **STOP•OPEN 9/** to open the cassette door.
4. Insert a suitable cassette into the cassette deck and close the cassette door.
5. Press **RECORD O** to start recording.
 - Playing of the CD programme starts automatically from the beginning of the programme. It is not necessary to start the CD player separately.

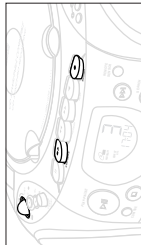

To select and record a particular passage within a track

- Press and hold down **SEARCH** or **S** (or on the remote control **5** or **6**).
- When you recognize the passage you want, release **SEARCH** or **S** (or on the remote control **5** or **6**).
- To pause CD playback, press **PLAY/PAUSE 2 ;**.
- Recording will begin from this exact point in the track when you press **RECORD O**.
- 6. For brief interruptions during recording press **PAUSE ;**. To resume recording, press **PAUSE ;** again.
- 7. To stop recording, press **STOP•OPEN 9/**.

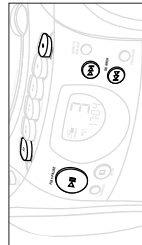

MAINTENANCE

Tape deck maintenance

To ensure quality recording and playback of the tape deck, clean parts **A**, **B** and **C** shown in the diagram below, after approx. 50 hours of operation, or on average once a month. Use a cotton bud slightly moistened with alcohol or a special head cleaning fluid to clean the deck.

1. Open the cassette door by pressing **STOP•OPEN 9/**.
2. Press **PLAY 1** and clean the rubber pressure rollers **C**.
3. Press **PAUSE ;** and clean the magnetic heads **A** and also the capstan **B**.
4. After cleaning, press **STOP•OPEN 9/**.

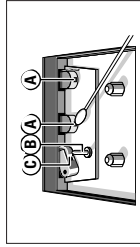

Note: Cleaning of the heads can also be done by playing a cleaning cassette through once.

Environmental information

All unnecessary packaging material has been omitted. We have done our utmost to make the packaging easy to separate into three mono-materials: cardboard (box), expandable polystyrene (buffer), polyethylene (bags, protective foam).

Your set consists of materials which can be recycled if disassembled by a specialized company. Please observe the local regulations regarding the disposal of packing materials, exhausted batteries and old equipment.

If a fault occurs, first check the points listed below before taking the set for repair. If you are unable to remedy a problem by following these hints, consult your dealer or service centre.

WARNING: Do not open the set as there is a risk of electric shock. Under no circumstances should you try to repair the set yourself, as this would invalidate the guarantee.

PROBLEM

- POSSIBLE CAUSE
- REMEDY

No sound/power

- Volume not adjusted
- Adjust the volume
- Headphones connected
- Disconnect headphones
- Mains lead not securely connected
- Connect the mains lead properly

Severe radio hum or noise

- Electrical interference: set too close to TV, VCR or computer
- Increase the distance

Poor radio reception

- Weak radio signal
- FM: Direct the FM telescopic aerial for optimum reception
- MW (AM): Turn the set for optimum reception

RF or Fd indication

- No CD inserted
- Insert a CD
- CD badly scratched or dirty
- Replace/ clean CD, see CD player and CD handling
- Laser lens steamed up,
- Wait until lens has cleared

RF indication

- CD-R(W) is blank or the disc is not finalised
- Use a finalised CD-R(W)
- CD badly scratched or dirty
- Replace/ clean CD, see CD player and CD handling

The CD skips tracks

- CD is damaged or dirty
- Replace or clean the CD
- SHUFFLE or a programme is active
- Switch off SHUFFLE/PROGRAM

Poor cassette sound quality

- Dust and dirt on the heads, etc.
- Clean deck parts etc., see Maintenance
- Use of incompatible cassette types (METAL or CHROME)
- Only use NORMAL (IEC I) for recording

Recording does not work

- Cassette tab(s) may be broken
- Apply a piece of adhesive tape over the missing tab space

Remote control does not function properly

- Batteries dead/ incorrectly inserted
- Insert (fresh) batteries correctly
- Distance/ angle between the set too large
- Reduce the distance/ angle

The typeplate is located on the bottom of the set.

ELECTRICAL PARTSLIST - CD99 DA11**- RESISTORS -**

4888	482205120008	Jumper
4889	482205120008	Jumper

- COILS & FILTERS -

1810	482224273557	Filter CST8,46MTW-TF01
5803	482215711231	Coil LAN02TB1R0J

- DIODES -

6877	482213011564	Diode UDZ3.9B
------	--------------	---------------

- IC & TRANSISTORS -

7800	482220917324	IC SAA7325H
7802	532220911517	IC PC74HCU04T
7803	532213060123	Trans BC807-40
7804	532220982941	IC LM358D
7807	532213042755	Trans BC847C
7808	482220932852	IC TDA7073A/N2
7809	482220932852	IC TDA7073A/N2
7810	482220933165	IC TDA1308T/N1
7875	482213060511	Trans BC847B

- MISCELLANEOUS -

1800	482226510925	Connector 15P
1823	482226511207	Connector 6P
1824	482226511207	Connector 6P
8000	482232012178	Flexible Foil 15P

Note : Only these parts mentioned in the list are normal service parts.

2001	2002	2003	2004	2005	2006	2007	2008	2009	2010	2011	2012	2013	2014	2015	2016	2017	2018	2019	2020	2021	2022	2023	2024	2025	2026	2027	2028	2029	2030	2031	2032	2033	2034	2035	2036	2037	2038	2039	2040	2041	2042	2043	2044	2045	2046	2047	2048	2049	2050	2051	2052	2053	2054	2055	2056	2057	2058	2059	2060	2061	2062	2063	2064	2065	2066	2067	2068	2069	2070	2071	2072	2073	2074	2075	2076	2077	2078	2079	2080	2081	2082	2083	2084	2085	2086	2087	2088	2089	2090	2091	2092	2093	2094	2095	2096	2097	2098	2099	2100
------	------	------	------	------	------	------	------	------	------	------	------	------	------	------	------	------	------	------	------	------	------	------	------	------	------	------	------	------	------	------	------	------	------	------	------	------	------	------	------	------	------	------	------	------	------	------	------	------	------	------	------	------	------	------	------	------	------	------	------	------	------	------	------	------	------	------	------	------	------	------	------	------	------	------	------	------	------	------	------	------	------	------	------	------	------	------	------	------	------	------	------	------	------	------	------	------	------	------	------

2101	2102	2103	2104	2105	2106	2107	2108	2109	2110	2111	2112	2113	2114	2115	2116	2117	2118	2119	2120	2121	2122	2123	2124	2125	2126	2127	2128	2129	2130	2131	2132	2133	2134	2135	2136	2137	2138	2139	2140	2141	2142	2143	2144	2145	2146	2147	2148	2149	2150	2151	2152	2153	2154	2155	2156	2157	2158	2159	2160	2161	2162	2163	2164	2165	2166	2167	2168	2169	2170	2171	2172	2173	2174	2175	2176	2177	2178	2179	2180	2181	2182	2183	2184	2185	2186	2187	2188	2189	2190	2191	2192	2193	2194	2195	2196	2197	2198	2199	2200
------	------	------	------	------	------	------	------	------	------	------	------	------	------	------	------	------	------	------	------	------	------	------	------	------	------	------	------	------	------	------	------	------	------	------	------	------	------	------	------	------	------	------	------	------	------	------	------	------	------	------	------	------	------	------	------	------	------	------	------	------	------	------	------	------	------	------	------	------	------	------	------	------	------	------	------	------	------	------	------	------	------	------	------	------	------	------	------	------	------	------	------	------	------	------	------	------	------	------	------

CD Part (sheet 1)

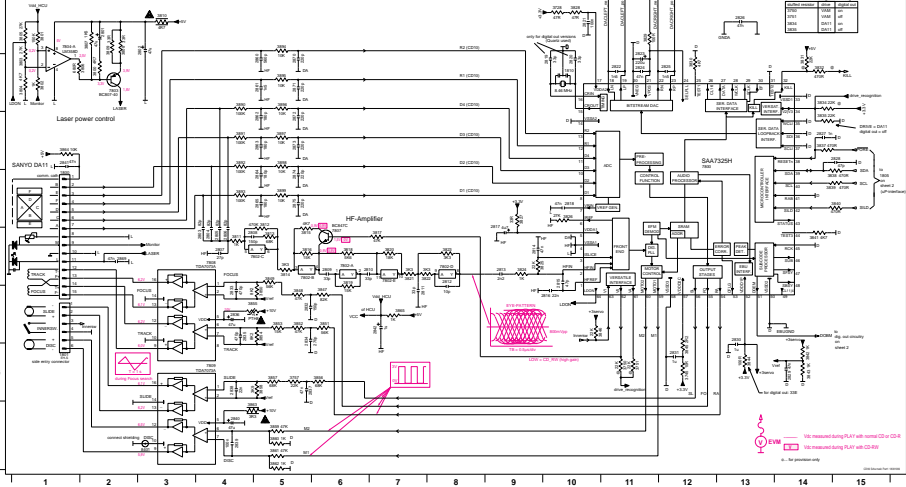

CD Part (sheet 2)

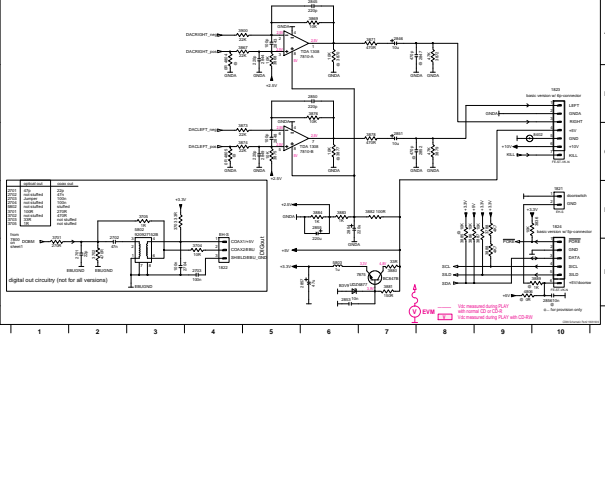

EXPLODED VIEW DIAGRAM - CABINET

13-1

13-1

13-1

SCREW LIST

- 1. C2 x 10
- 2. C2 x 12
- 3. C2.5 x 9.5
- 4. C3 x 7.5
- 5. C3 x 9
- 6. C3 x 9
- 7. C3 x 10
- 8. C3 x 12
- 9. C3 x 34
- 10. C P/W 2.5 x 16
- 11. C P/W 3 x 10
- 12. C P/W 3 x 14

