



Pentair Water

Model PB5RO-75 Undersink Reverse Osmosis System

User Manual

OPERATING SPECIFICATIONS

⚠ WARNING: Before installing the system, make certain your water supply complies with the following operating specifications. Failure to do so may reduce the effectiveness of the system and will void the warranty. Consult your local water treatment utility or a certified water testing lab to determine the quality of your water and use the table below to record your results for future reference.

| PB5RO-75 Specifications | | Your Water |
|--------------------------------|-----------------------------|------------|
| Pressure Range: | 40–100 psi (2.8–6.9 bar) | |
| Temperature Range: | 40–100°F (4.4–37.8°C) | |
| Total Dissolved Solids | < 2000 ppm | |
| Maximum Hardness* †: | 10 gpg (171 mg/L) | |
| Sulfide, Iron and Manganese †: | < 0.1 | |
| Chlorine in Water Supply: | < 2 ppm | |
| Water Supply pH Limits: | 3–11 | |
| Turbidity: | 5 NTU Max. | |
| Date of Purchase: | | |

* If the hardness of your water is above 10 gpg (171 mg/L), lime scale will build up rapidly on the membrane inside of the RO membrane cartridge. Scale buildup will plug the RO membrane cartridge and make the system ineffective. We do not recommend the PB5RO to be used with water in excess of 10 gpg (171 mg/L) hardness, unless the water is softened prior to the reverse osmosis system.

† See your local dealer or water treatment specialist to reduce these substances in your water.

PB5RO-75 Dimensions:

| | |
|-------------------|--|
| System Dimensions | 13" H x 18.6" W x 4.75" D (330 x 3472 x 120.6 mm) |
| Tank Dimensions | 14.5" H x 11" Dia (368 x 279 mm) |
| System Weight | 29 lbs (10.4 kg) |
| Tank Capacity | 3.2 gal (12.1 L) |

Tools Required

- Hand or Electric Drill
- 2 Adjustable Wrenches
- File
- Pencil
- Needle-nose Pliers
- Utility Knife or Tube Cutter (for plastic tubing)
- Phillips Screwdrivers
- Drill Bits: 1/8", 1/4" and 3/8"
- Towel
- Safety Glasses
- Tape Measure

Optional Materials

(For sinks without extra hole for faucet)

- Hand or Electric Drill
- Drill Bits: 1/4" and 3/4"
- Teflon® Tape
- Center punch
- Respirator
- 1-3/8" Bi-metal or Carbide Tipped Hole-saw

NOTE: All tools listed will not be necessary for installation. Read installation procedures before starting to determine required tools.

Parts Included

- Head Assembly
- Screws for mounting
- Lead-free air gap drinking water faucet
- Silicone grease
- Tank Valve
- Teflon® Tape
- 3/8" Plastic Tubing (red and blue)
- TDS Test Kit
- Filter Cartridges:
PW-S2500R Cartridge Yellow
PW-C5000R Cartridge Blue
PW-RO75R Cartridge Green
PW-C2500R Cartridge Violet
- Drain Saddle Valve
- Water Supply Adapter
- Quick-connect Fitting
- Storage Tank
- Faucet Adapter
- Change Indication Sticker
- 1/4" Plastic Tubing (white, red and green)

GENERAL PRECAUTIONS

▲ WARNING: Do not use with water that is microbiologically unsafe or of unknown quality without adequate disinfection before or after the system. Systems certified for cyst reduction may be used on disinfected waters that may contain filterable cysts.

▲ WARNING: The PB5RO contains a replaceable RO membrane cartridge that is critical to the efficiency of the system. Replacement of the RO membrane cartridge should be with one of identical specifications, as defined by the manufacturer, to assure the same efficiency and contaminant reduction performance.

▲ WARNING: The PB5RO contains a replaceable RO membrane cartridge, critical for the effective reduction of total dissolved solids. Product water should be tested periodically to verify that the system is working properly.

▲ WARNING: The PB5RO is acceptable for treatment of influent concentrations of no more than 27 mg/L nitrate and 3 mg/L nitrite in combination measured as N and is certified for nitrate/nitrite reduction only for water supplies with a pressure of 40 psig (280 kPa) or greater.

▲ WARNING: The PB5RO shall only be used for arsenic reduction on chlorinated water supplies containing detectable residual free chlorine at the system inlet. Water systems using an in-line chlorinator should provide a one-minute chlorine contact time before the unit.

▲ WARNING: The PB5RO will not protect against disease-causing bacteria or remove naturally-occurring harmless bacteria.

CAUTION The PB5RO must be protected against freezing which can cause the filter housing to crack, resulting in water leakage.

CAUTION Turn off water supply to head without cartridge if it must be left unattended for an extended period of time.

CAUTION Do not use electrical heating tape on this unit.

NOTE: Substances listed as reduced are not necessarily in your water. System must be maintained according to manufacturer's instructions, including replacement of filter cartridges.

NOTE: Your water must be within required limits for satisfactory operation. If not, the RO membrane cartridge's life may be shortened and your warranty will be voided (see Operating Specifications).

NOTE: Install on cold water line only.

NOTE: Do not install where system will be exposed to direct sunlight.

NOTE: Make certain that installation complies with all state and local laws and regulations.

NOTE: The filter cartridges and RO membrane cartridge included with the system have limited service lives. Changes in taste, odor, and color of the filtered water indicate that the cartridges and/or membrane should be replaced.

NOTE: During extended periods of non-use (such as during a vacation), remove the membrane cartridge and the filter cartridges from the unit and place them in a sealed plastic bag. Store the cartridges in the refrigerator for future use. When re-starting the unit, replace all cartridges and flush per instructions.

NOTE: If the PB5RO stands for more than 2 to 3 days without being used, the storage tank should be emptied.

NOTE: Use only Teflon® tape without adhesive backing to seal joints. Do not use pipe compound ("pipe dope"), sticks, or similar compounds with this unit; they contain petroleum derivatives which can cause crazing and cracking of the plastic in the filter housing.

NOTE: Use only soap and water to clean components.

NOTE: Do not use aerosol sprays (bug spray, cleaning fluids, etc.) near the PB5RO. They contain organic solvents which will cause crazing and cracking of the plastic in the filter housing.

NOTE: After prolonged periods of non-use, such as a vacation, it is recommended that the system be flushed thoroughly. Let water run for 2 to 3 minutes before using.

NOTE: Do not use a torch near the unit.

HOW REVERSE OSMOSIS (RO) WORKS

The PB5RO uses a semi-permeable membrane to reduce dissolved salts, improving the taste and odor of your water. The RO membrane cartridge contains multiple layers of micron-thin film wound around a hollow center core. Water molecules can pass through the cartridge, while dissolved salts are rejected.

Your household water supply is pre-filtered to reduce dirt and chlorine that may foul the membrane. The RO membrane cartridge separates this pre-filtered water into PRODUCT WATER and REJECT WATER. Your household water pressure forces water through the membrane within the RO membrane cartridge, and into the storage tank. This is product water. Dissolved salts cannot pass through the membrane and are sent to the drain as reject water. When you open the faucet, product water (permeate) is drawn from the storage tank through a post-polishing filter. The post-polishing filter takes out any remaining taste or odor in the water and provides you and your family with cleaner, great-tasting water.

The PB5RO also features an auto shut-off valve, which shuts off the system once the pressure in the storage tank reaches 2/3 of the incoming water pressure (your household water pressure). When you open the faucet to draw water from the storage tank, the pressure inside the tank drops and the auto shut-off valve opens. The system then begins to operate, replenishing the water you took from the storage tank. Depending on the system's efficiency, for each gallon of water produced, up to 7 gallons are discharged as reject water. The storage tank can hold up to 3.2 gallons (12.1 L) of water at a time, more than enough for the average family's drinking and cooking needs.

NOTE: When used under operating conditions specified on page 1 of this manual, the RO membrane cartridge of the PB5RO should last 12–24 months. The precise life span of the PB5RO's RO membrane cartridge will depend on the quality of the water entering the system, and the frequency with which you use it. Frequent use prevents the dissolved salts from building up on the membrane as scale. The more water the system is required to produce, the longer the membrane will last. You may wish to find a variety of uses for your PB5RO system in order to prolong the life of the membrane.

INSTALLATION

NOTE: Please read all instructions, specifications, and precautions before installing and using your PB5RO system.

NOTE: The PB5RO may be installed under a sink or in the basement.

NOTE: The PB5RO is installed vertically.

NOTE: Numbered diagrams correspond with numbered steps.

NOTE: For standard installation on 1/2" 14 NPS threads (most common thread on kitchen faucets) cold water line.

1. Installing the Water Supply Adapter

The supply adapter fits 1/2" 14 NPS supply threads. If local codes permit, it may be used to connect the filter system to the cold water supply line. If local codes do not permit the use of the supply adapter, alternate connectors can be obtained from your local retailer.

- Turn off cold water supply line. If cold water line does not have a shut-off valve under the sink, one should be installed.
- Turn on the cold water faucet and allow all water to drain from line.
- Disconnect cold water line from 1/2" 14 NPS threaded stub on bottom of main faucet.
- Screw the water supply adapter to the threaded faucet stub as shown.
- Using the nut that previously connected the cold water line to the faucet, screw the cold water line to the male supply adapter threads.

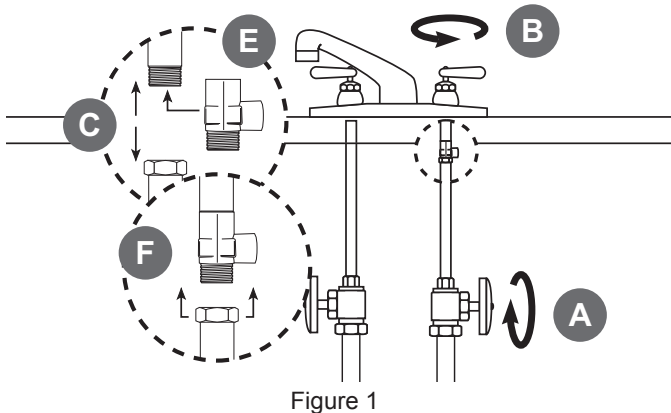

Figure 1

2. Selecting the Faucet Location

NOTE: The drinking water faucet should be positioned with function, convenience, and appearance in mind. An adequate flat area is required to allow faucet base to rest securely. The faucet fits through a 1-3/8" hole. Most sinks have pre-drilled 1-3/8" or 1-1/2" diameter holes that may be used for faucet installation. If these pre-drilled holes cannot be used or are in an inconvenient location, it will be necessary to drill a 1-3/8" hole in the sink to accommodate the faucet.

⚠ WARNING: This procedure may generate dust which can cause severe irritation if inhaled or come in contact with the eyes. The use of safety glasses and respirator for this procedure is recommended.

⚠ WARNING: Do not attempt to drill through an all-porcelain sink. If you have an all-porcelain sink, mount the faucet in pre-drilled sprayer hole or drill through countertop next to sink.

⚠ WARNING: When drilling through a countertop, make sure the area below the drilled area is free of wiring and piping. Make certain that you have ample room to make the proper connections to the bottom of the faucet.

⚠ WARNING: Do not drill through a countertop that is more than 1" thick.

⚠ WARNING: Do not attempt to drill through a tiled, marble, granite or similar countertop. Consult a plumber or the countertop manufacturer for advice or assistance.

- Line bottom of sink with newspaper to prevent metal shavings, parts, or tools from falling down drain.
- Place masking tape over the area to be drilled to help prevent scratches if drill bit slips.
- Mark hole with center punch. Use a 1/4" drill bit for a pilot hole.
- Using a 1-3/8" hole saw, drill a hole completely through the sink. Smooth the rough edges with a file.

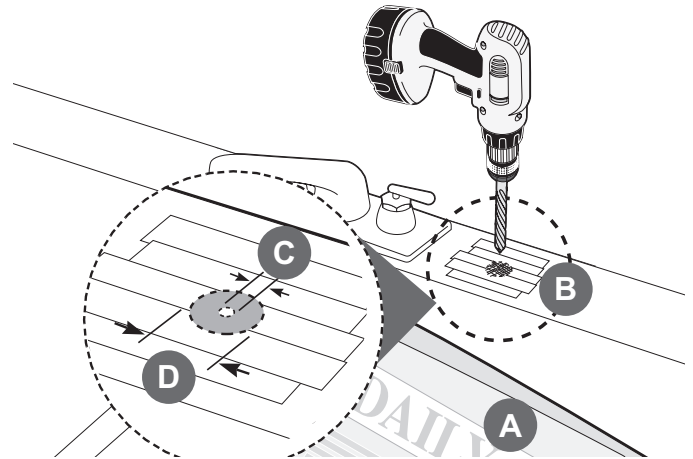

Figure 2

INSTALLATION *continued*

3. Mounting the Faucet

- A. Pre-assemble the base. The rubber washer should be in place below the base. The two toggle bolts should be inserted through the base and the rubber washer. The bolts are screwed into the spring-loaded toggle.
- B. Place the base assembly over the hole in the sink. The two toggles should pass through the hole far enough to spring fully open. If they are not open, unscrew the bolt until the toggle moves down to clear the sink.
- C. Look down through the base for this step. Before tightening the bolts, determine the correct rotation of the base. The final position of the handle will be 45 degrees off from the bolt heads. Use Figure 5 to help determine the best position for your installation. Through the hole in the base, hold the toggle in position while tightening the bolt. The spring loaded toggle will contact the bottom of the counter top and hold in position. Do not fully tighten. Repeat for second toggle bolt. Check the final position of the base and toggle bolts. Tighten the two bolts evenly. **DO NOT OVERTIGHTEN.** Tighten only far enough to prevent the base from rotating when the faucet is rotated in place.
- D. Attach large diameter 3/8" (red) drain tube to the larger barb fitting at the faucet bottom. This tube should be long enough to reach the drain clamp in Step 7.
- E. Locate the 1/4" red brine tube from the right side of the system head assembly. Route the tube through the faucet base and connect to small barb on the faucet. Make certain that the tube is not kinked or stressed once the head assembly is mounted.
- F. Apply 3-5 wraps of Teflon tape to faucet stem. Screw quick connector onto end of threads.
- G. Wet end of 3/8" blue tube. Push into bottom of connector. Tug gently to be sure connection is complete. This tube should be long enough to reach the top right side of the RO Assembly.
- H. Check that the O-ring is in place on the faucet. Feed the remaining 3/8" tubes through the base. Hold the faucet in the final position and rotate backwards (to the left) while pushing down. The faucet will drop into the base. Push down on the faucet and rotate forward (to the right) to lock it into final position. The O-ring will be seated and the faucet held securely in position.
- I. Insert the spout into the top opening. Hold in position and screw the collar onto the base.

NOTE: If the faucet handle is not in the correct position, remove the faucet, loosen the toggle bolts and reposition the base. Tighten the toggle bolts. Then reinstall the faucet.

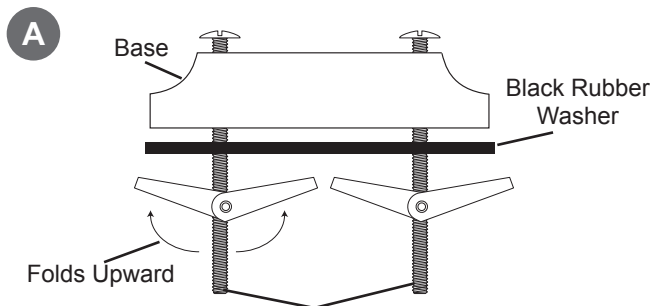

Figure 3

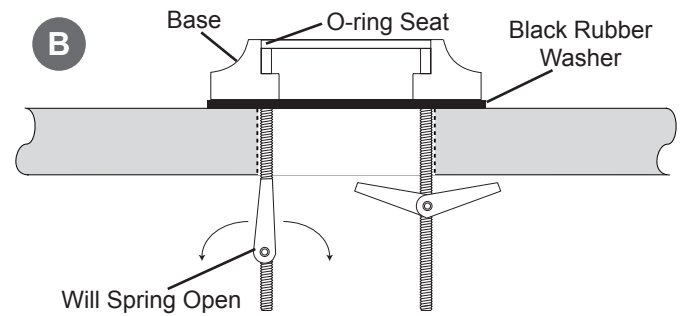

Figure 4

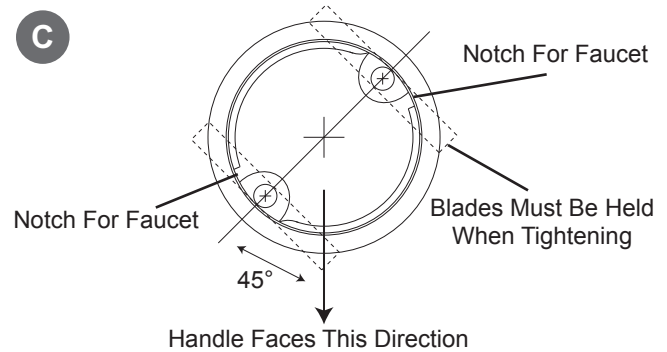

Figure 5

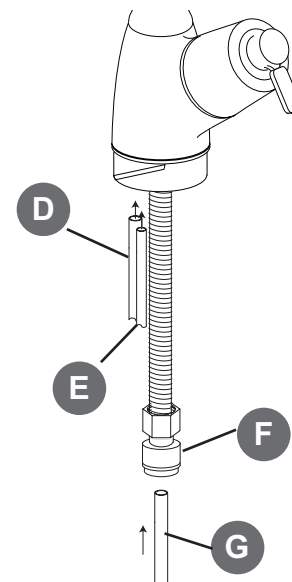

Figure 6

4. Mounting the System

CAUTION The filter head assembly should be mounted on a stud or firm surface. The mounting bracket will support the weight of the cartridges and help prevent strain on the water lines.

- A. Select location under sink or in basement where unit is to be mounted. The head assembly is mounted in a vertical position.
- B. When mounting the PB5RO-75 the top of the head must be 15-1/2" above the nearest obstacle (floor of the cabinet). Two screws are supplied to mount the head. Measure up from the floor of the cabinet 14-1/2". The two screws will be 17.7" apart and level. Screw the two

INSTALLATION *continued*

screws into the wall. Leave a gap between the screw head and the wall of 1/8". The backside of the system head has two slots that will fit over the screw heads and slide down to lock.

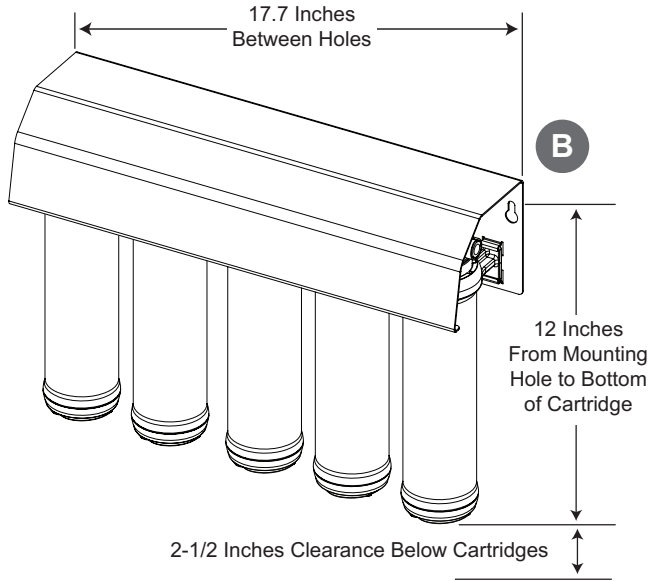

Figure 7

5. Connecting the Faucet

CAUTION Water supply to the tee should have a separate shut-off valve. If it does not, a separate shut-off should be installed.

- Locate the 3/8" blue tubing from the faucet and place a mark 5/8" from the end of the tubing. Moisten the end of the tubing with water and insert into the quick-connect fitting on the head assembly until the mark is flush with the quick-connect fitting.
- Gently pull back on the tubing to ensure it is connected properly. If the tubing comes out of fitting, cut a small section off of the tubing and reconnect.

NOTE: Tubing may be quickly and easily removed from the fitting if necessary. First, turn off the water supply to the filter. Open faucet, then press in the collet around the fitting while pulling the tubing with your other hand.

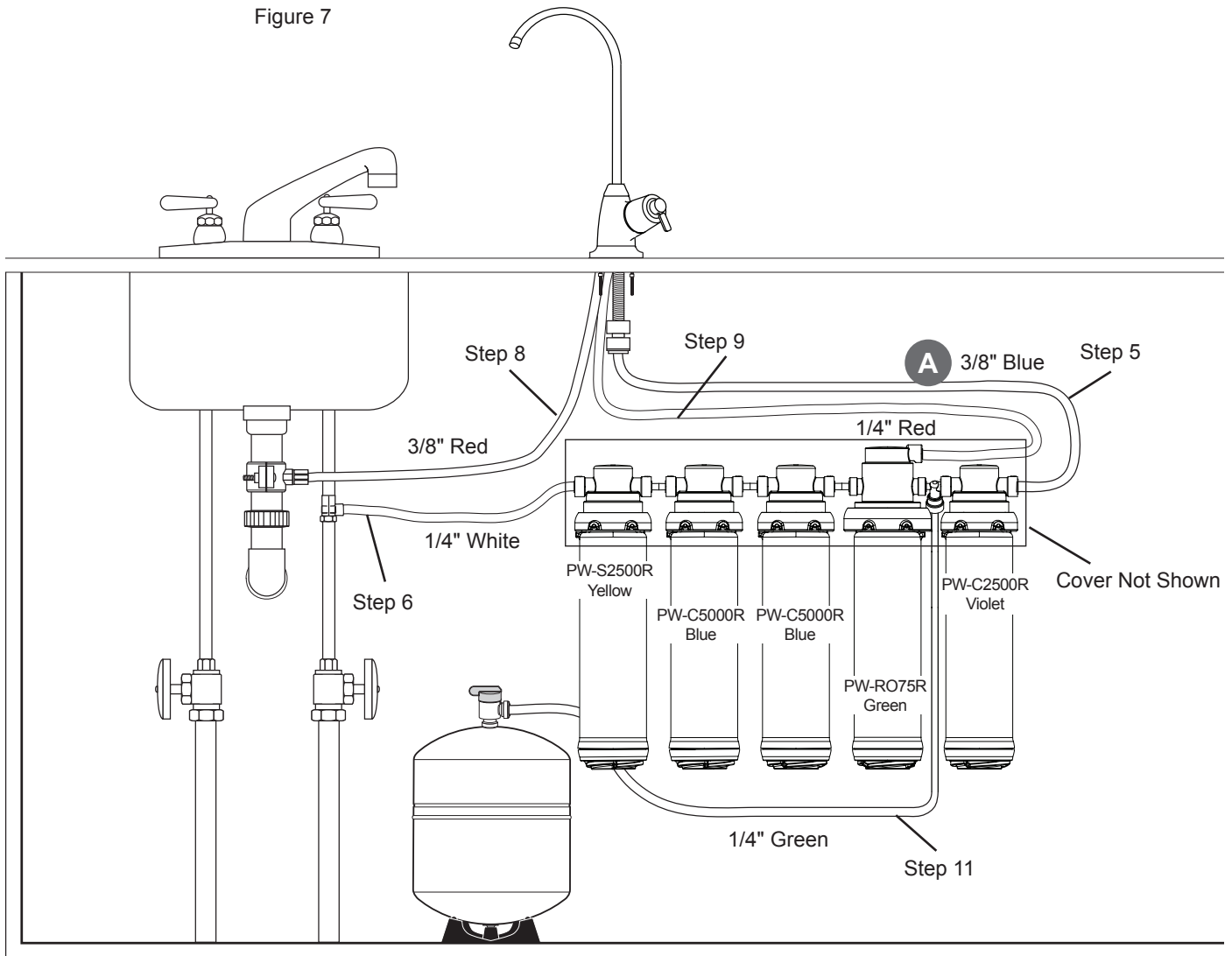

Figure 8

INSTALLATION *continued*

6. Connecting the Water Supply Adapter

- Determine the length of 1/4" white plastic tubing needed to connect the inlet (white collet) on the left side of the filter with the water supply adapter. Be sure to allow enough tubing to prevent kinking and cut the tubing squarely. Place a mark 5/8" from the end of the tubing.
- Wet tubing with water and insert into water supply adapter 5/8" until mark is flush with fitting. Repeat inserting other end of tubing into inlet of the head assembly.

7. Installing the Drain Clamp

NOTE: If you have a single-basin sink with a disposal unit, call Technical support at 1-800-279-9404 for options.

NOTE: Before installing the drain clamp, check the drainpipes under the sink for corrosion. Corroded pipes should be replaced before continuing with installation.

- Attach the drain clamp to a vertical section of the drainpipe, about 6" above the trap. Make sure the opening on the drain clamp is facing towards the drinking water faucet.
- Using the fitting hole of the drain clamp as a guide, drill a 1/4" hole through one side of the drainpipe.
- Remove the drain clamp from the drainpipe and enlarge the hole with a 3/8" drill bit. Use a file to remove rough edges from the drilled hole.
- Make sure the black rubber gasket is adhered to the inside of the drain clamp and place the drain clamp assembly over the drilled hole. Look through the hole and position the clamp so that the center of the clamp hole is slightly higher (about 1/16") than the center of the drilled hole. (See Figure 11). Tighten the clamp securely.
- Screw the plastic compression nut onto the drain clamp until hand-tight.

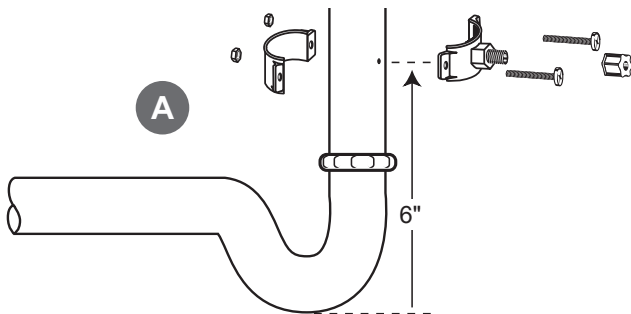

Figure 9

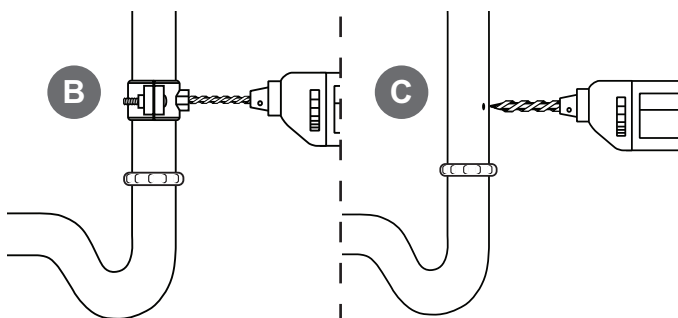

Figure 10

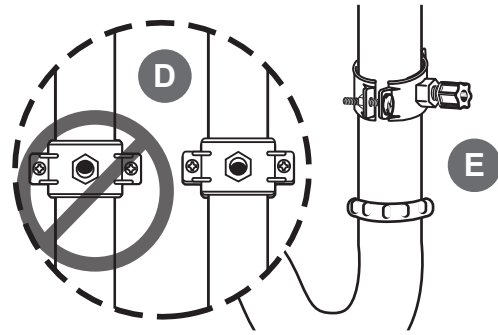

Figure 11

8. Connecting the Faucet to the Drain

NOTE: This is a gravity drain line. Any loops, kinks or sharp bends must be eliminated before proceeding. Failure to create a straight line to the drain may result in reject water leaking through the air gap in the faucet onto the counter top and below the faucet.

- Align the 3/8" red tubing from the faucet with the compression nut on the drain clamp. Create as straight a path as possible with the tubing. Cut the tubing squarely below the nut and remove the internal and external burrs.
- Loosen the compression nut two complete turns. Insert the tubing into the nut until it stops. Tighten with fingers, then tighten 1 to 2 turns with a wrench.

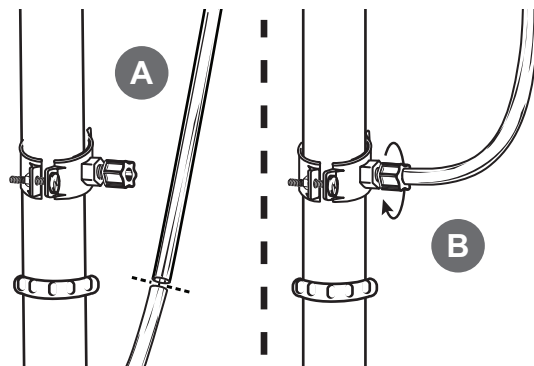

Figure 12

INSTALLATION *continued*

9. Installing the Cartridges

The cartridges are identified by the color of the label and the model number.

Cartridge #1 = PW-S2500R, Yellow

Cartridge #2 = PW-C5000R, Blue

Cartridge #3 = PW-C5000R, Blue

Cartridge #4 = PW-RO75R, Green

Cartridge #5 = PW-C2500R, Violet

Install the cartridges in order. If the cartridges are installed out of order the system will not filter correctly.

- Slide the cartridge into the head until it can go no further.
- Twist the cartridge 1/4 turn clockwise until it snaps into place. Gently pull the cartridge straight out to ensure the cartridge is locked into place.

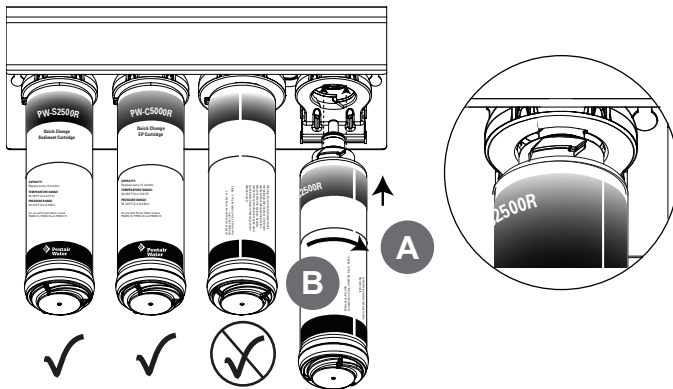

Figure 13

10. Connecting the Storage Tank to the System

CAUTION When tank is full, it weighs approximately 35 pounds. Provide ample support under the tank.

- Apply 3-5 wraps of Teflon tape to the tank threads.
- Thread the tank valve onto the top of the tank opening by turning it clockwise until snug.
- Locate the green tubing and a mark 3/4" from the end. Moisten one end of the green tubing with water and insert with a twisting motion into the free port of the tank valve until the 3/4" mark is flush with the quick-connect fitting.

NOTE: Do not cut green tube. This line should be left at the pre-cut length for future service.

NOTE: The pressurized storage tank has capacity of 3.2 gallons. The tank's air pressure is factory set at 5 to 7 psi when tank is empty.

11. Putting the System Into Operation

CAUTION Make certain head assembly is firmly attached to wall to prevent it from falling and possibly becoming damaged.

NOTE: Use caution not to bend or pinch the tubing behind the system while attaching to mounting screws.

NOTE: The post-polishing filter may contain fine black carbon particles. These fines are harmless, but may make the water appear gray in color. The carbon fines are flushed from the system with the first tank full of water.

NOTE: The PB5RO system does not produce a high volume of water on demand as an ordinary filter does. Water is produced at a slow, drop-by-drop rate. The system requires about 3 hours to fill the storage tank. As water is taken from the tank, the system automatically starts the cycle of replacing the water and then stops water production when the tank is full.

- Make sure cold water faucet is "off" (Figure 14).
- Make sure tank valve is in the open position.
- Slowly turn on cold water supply.
- Open the faucet to turn on flow. Let the faucet run/drip for 12 hours, then close it.
- Allow 3 hours for the tank to fill. Continue to periodically check the installation for leaks. After the storage tank is filled, open the faucet to flush the post-filter cartridge (on the right side of the filter housing). Allow 4 to 5 minutes for all of the water to drain from the tank. Close faucet and allow tank to fill.

CAUTION Visually check the entire system for leaks. If a leak is present, see TROUBLESHOOTING.

- Repeat Step E four times.

NOTE: Initially, the water may appear cloudy. This is a result of air trapped in the post-filter cartridge. It is not harmful and will disappear in a matter of minutes. It may take up to a week after installing a new post-filter cartridge for the trapped air to dissipate.

The system is ready for operation. You can now enjoy quality water from the PB5RO-75.

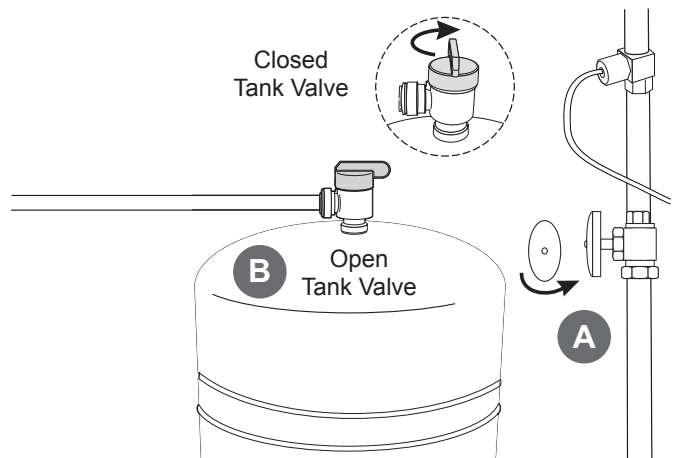

Figure 14

OPTIONAL INSTALLATION

CONNECTING THE PB5RO-75 TO REFRIGERATOR ICEMAKER/WATER DISPENSER

CAUTION If you are connecting the PB5RO to your refrigerator/icemaker with initial system installation, wait to turn on the icemaker until the Post- Filter Cartridge (on the right side of the filter housing) has been flushed according to Step 11.

CAUTION Use plastic tubing and fittings. Do not use copper tubing or brass fittings.

NOTE: For optimum performance, it is recommended that the distance between the PB5RO and the refrigerator icemaker/water dispenser be no greater than 10 feet (3 m). At distances greater than 10 feet, the water pressure from the system may not be adequate to deliver water to the refrigerator.

Materials Required

(available from your local hardware store)

- 3/8" x 3/8" x 3/8" (9.5 x 9.5 x 9.5 mm) compression or quick-connect tee.
 - 3/8" (9.5 mm) polyethylene tubing (maximum length of 10 feet [3 m] recommended)
 - Shut-off valve
- Turn off icemaker and refrigerator water supply. Consult manufacturer's guidelines.
 - Close tank valve (on top of storage tank).
 - Turn off water to the system at the cold water supply.
 - Open drinking water faucet to relieve pressure.
 - Locate blue tubing leading to your drinking water faucet. Cut and insert the 3/8" x 3/8" x 3/8" (9.5 x 9.5 x 9.5 mm) compression or quick-connect tee into the blue tubing (Figure 15). Consult manufacturer's guidelines before installing the tee connection.

NOTE: When cutting the blue tubing, you may experience some water leakage.

- Using a length of 3/8" polyethylene tubing, connect the icemaker/dispenser line with the free port on the compression tee.
- The shut-off valve should be installed as close to this port of the tee as possible. Shut-off valve should be installed in the OFF position. Consult manufacturer's guidelines before installing the shut-off valve.
- Completely open cold water supply (until it comes to a stop).
- Open tank valve.
- Turn off the drinking water faucet.
- Open shut-off valve at the tee connection.
- Turn on ice maker. Consult manufacturer's instructions.
- Check for leaks and tighten connections if necessary.

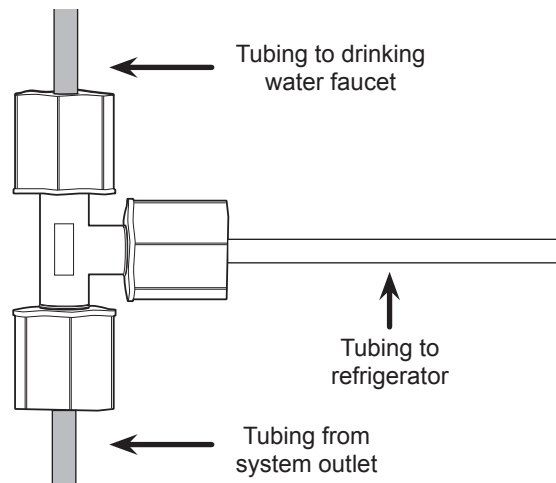

Figure 15

TESTING YOUR REVERSE OSMOSIS SYSTEM

Total Dissolved Solids (TDS) Test

NOTE: Under NSF/ANSI Standard 58, it is highly recommended that you (the consumer) have your water tested at least every 6 months to verify that your system is performing satisfactorily.

Sampling Instructions:

Sampling instructions are included with the Total Dissolved Solids (TDS) Test Kit. If the TDS Test Kit is missing from your unit, please call Customer Support at 1-888-837-0028 for a replacement.

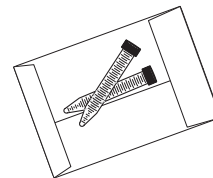

Total Dissolved Solids Test Kit

Figure 16

WHEN TO CHANGE THE CARTRIDGES

The life of the cartridge depends on the water volume used and the substances in the water. Normally, cartridges should be changed at intervals of 6 months. Replace the cartridge sooner if the water pressure at the faucet begins to drop noticeably or if you notice changes in the taste, color, or flow of the filtered water.

CHANGING THE CARTRIDGES

Materials Needed

- Replacement Cartridges (color coded):
PW-S2500R Cartridge Yellow (1)
PW-C5000R Cartridge Blue (2)
PW-RO75R Cartridge Green (1)
PW-C2500R Cartridge Violet (1)

The pre-filter and post-filter cartridges need to be changed when the water pressure at the faucet begins to drop noticeably, or if there are changes in taste, color or flow of the filtered water. All cartridges should be changed at the same time. The cartridges are color coded to indicate which location they are installed into.

1. Changing the Cartridges

NOTE: Only the replacement cartridges listed can be used with this system. Failure to use recommended replacement cartridges will void your warranty.

- A. Place a small pan or towel under the PB5RO to catch any water that may drip.
- B. Twist the pre-filter cartridge (on the left side of the filter housing) counter-clockwise for a 1/4 of a turn, and pull the cartridge out of the system. If the system has any significant leaks, see Troubleshooting.
- C. Push the new cartridge into the head until it can go no further.
- D. Twist the cartridge 1/4 turn clockwise until it snaps into place.
- E. Gently pull the cartridge straight out to ensure the cartridge is locked into place.
- F. Repeat for all other cartridges.
- G. Turn on water and check for leaks. If leaks are found, see Troubleshooting.

NOTE: The post filter cartridge may contain carbon fines (very fine black powder). This will be released during your initial flushing.

- H. Flush water through the system for 5 minutes to remove carbon fines. Check for leaks again before leaving installation. Allow the tank to fill.

2. Flushing the RO membrane

NOTE: The PB5RO system does not produce a high volume of water on demand as an ordinary filter does. Water is produced at a slow, drop-by-drop rate. The system requires about 3 hours to fill the storage tank. As water is taken from the tank, the system automatically starts the cycle of replacing the water and then stops water production when the tank is full.

- A. Make sure cold water faucet is "off" (Figure 14).
- B. Make sure tank valve is in the open position.
- C. Slowly turn on cold water supply.
- D. Open the faucet to turn on flow. Let the faucet run/drip for 12 hours, then close it.
- E. Allow 3 hours for the tank to fill. Continue to periodically check the installation for leaks. After the storage tank is filled, open the faucet to flush the post-filter cartridge (on the right side of the filter housing). Allow 4 to 5 minutes for all of the water to drain from the tank. Close faucet and allow tank to fill.

CAUTION Visually check the entire system for leaks. If a leak is present, see TROUBLESHOOTING.

- F. Repeat Step E four times.

TROUBLESHOOTING

Leaks on Supply Adapter Connection

1. Turn off water supply valve and turn on drinking water faucet to release pressure in system.
2. Loosen leaking threaded fitting on supply adapter or pull out leaking tubing by pressing collar surrounding tubing while pulling the tubing with your other hand.
3. Inspect to see if plastic tubing is scratched and supply adapter was properly attached.
4. If tubing is scratched, cut off 1/2" to 5/8" and reinstall.

Leaks on Faucet/Tubing Connection

1. Turn off water supply valve and turn on drinking water faucet to release pressure.
2. Unscrew tubing nut at bottom of faucet. Inspect the tubing. The insert, plastic ring and tubing should not be damaged.
3. Check if insert is in place and tubing is cut squarely and not scratched, cut tubing if necessary to get square smooth end.
4. If the tubing is smooth and square, reconnect tubing by inserting into faucet and tightening nut. The plastic ring should be held tight to the faucet system when the nut is tight.
5. Turn on water supply valve, then close faucet and check for leaks.

NOTE: If leaks persist, or if there are other leaks on system, turn off water supply and call Technical Support 1-800-279-9404.

Leaks Between Cartridge and Filter Housing

1. Turn off cold water supply to system at saddle valve. Close tank valve. Open drinking water faucet to relieve water pressure.
2. Remove the cartridge, inspecting it for damage. Inspect O-rings to make sure they are seated and clean.
3. Insert and twist the cartridge back into the filter housing.
4. Turn on water supply at saddle valve. Open tank valve. Close drinking water faucet after water begins to flow. If leaks persist, call Technical Support.

Leak Between Tank Valve and Storage Tank

1. Turn off water supply to system at the saddle valve. Open faucet to drain storage tank. Let faucet run for 3–5 minutes until it drips.
2. Remove green tubing from tank valve by pressing the collar around the fitting while pulling the tubing with your other hand.
3. Unscrew the tank valve from the storage tank.
4. Place three wraps of Teflon® tape on the threads of the storage tank.
5. Thread the tank valve onto the top of the tank opening by turning it clockwise until snug.
6. Cut off 1" of tubing. Tubing should be cut squarely. Internal and external burrs should be removed. Place a mark on tubing 3/4" from end of tubing.
7. Wet the tubing and insert until the mark is flush with the quick-connect fitting.
8. Turn water supply on at the saddle valve and close drinking water faucet.
9. Allow system to pressurize for several hours and check for leaks.
10. Check for leaks after tank is fully pressurized (1–3 hours). If leak persists, call Technical Support.

TROUBLESHOOTING *continued*

Leaks at Quick-Connect Fittings

CAUTION The 1/4" red tubing connected to the top of the fourth cartridge has a flow restrictor installed. The system will not operate correctly if the restrictor is removed.

1. Close tank valve, close saddle valve, and open drinking water faucet.
2. Press collar around the quick-connect fitting while pulling the tubing with your other hand.
3. Cut off 1" of tubing. Tubing should be cut squarely. Internal and external burrs should be removed. Place a mark on tubing 5/8" from end on 1/4" tubing or 3/4" from end on 3/8" tubing.
4. Wet the end and insert tubing until the mark is flush with the quick-connect fitting.
5. Open the saddle valve until it comes to a stop. Open the tank valve and close drinking water faucet. If leaks persist, call Technical Support.

Leaks from Faucet

1. Check to make sure white tubing leading from the drinking water faucet to the drain is as straight as possible (it is usually necessary to cut this line during installation). Any kinks or sags in this drain line will impede the flow of water to the drain.
2. Check to make sure the drain clamp and the drain hole are properly aligned. (Refer to Figure 7 on page 7).
1. Check to make sure there is no foreign matter clogging the drain line or at the drain clamp hole. If leaks persist, call Technical Support.

No Flow or Slow Flow from the Brine (Reject) Line (Less than 6 fl. oz. or 180 milliliters per minute)

NOTE: Before checking brine (or reject) flow, make sure the unit is producing water by turning the valve on the storage tank off and opening the drinking water faucet. Water should drip from faucet.

1. Replace the pre-filter cartridge according to the changing the filter cartridge instructions and recheck the brine (or reject) flow rate.
2. If the pre-filter cartridge is not at fault, the brine (or reject) flow controller could be clogged. Call Technical Support.

High TDS in Product Water

1. If high TDS (Total Dissolved Solids) is detected in the product water, the RO Cartridge may need to be replaced or the reject flow control tubing may be clogged. If this is a new installation, call Technical Support.
2. Otherwise, draw 1 gallon of water from the unit. After 10 minutes, then run water from the faucet and test the water again.
3. Determine when you last changed the RO Filter Cartridge and call Technical Support.

Limited Flow at Drinking Water Faucet

1. Turn off water supply to system at saddle valve.
2. Open the faucet to turn on flow.
3. Unscrew the blue cap at the base of the storage tank to expose air valve. Use a small air compressor or bicycle pump to add air to the storage tank. This will force the water out of the storage tank through the faucet. Continue to add air until no more water comes out of the faucet.
4. Turn off the drinking water faucet.
5. Using an air pressure gauge, adjust the pressure in the storage tank to 5–7 psi.
6. Replace the blue cap.
7. Open the saddle valve until it comes to a stop. Let the system run 1–3 hours to fill the tank. A full tank weighs approximately 33 pounds. If performance has not improved, call Technical Support.

Sudden Return of Taste and Odor

If shortly after complete servicing, noticeable taste and odors return, contact Technical Support.

If you are experiencing a problem not listed in this manual, shut off the water supply at the saddle valve and close the tank valve. Call Technical Support.

▲ WARNING: Do not use with water that is microbiologically unsafe or of unknown quality without adequate disinfection before or after the system. Systems certified for cyst reduction may be used on disinfected waters that may contain filterable cysts.

NOTE: Substances that may be reduced are not necessarily in your water. Filter must be maintained according to manufacturer's instructions, including replacement of filter cartridges.

MAINTENANCE

Contact your water treatment professional for replacement cartridge pricing.

SUGGESTED LIST PRICE

REPLACEMENT CARTRIDGES

- 555612-96 PWS2500R: \$8.94
- 555586-96 PW-C500R: \$18.54
- 555613-96 PW-RO75R: \$44.00
- 555585-96 PW-C2500R: \$12.16

REPLACEMENT PARTS

For replacement parts contact your local retailer or call Customer Service at 1-800-279-9404.

| Item # | Part Number | Description | QTY |
|--------|-------------|---|-----|
| 1 | 244877 | Storage Tank 3.2 Gal | 1 |
| 2 | 555612-96 | Cartridge, Sediment PW-S2500R, Yellow | 1 |
| 3 | 555586-96 | Cartridge, Carbon Block PW-C5000R, Blue | 2 |
| 4 | 555676-96 | Cartridge, RO Element, 75 GPD PW-RO75R, Green | 1 |
| 5 | 555585-96 | Cartridge, GAC PW-C2500R, Violet | 1 |
| 6 | 244876 | Kit, Faucet | 1 |
| | 244857 | Faucet, Air Gap - Paragon (includes toggles) | 1 |
| | 244783 | Valve, RO Tank 1/4" NPT x 1/4" QC | 1 |
| | 247117 | Label, Water Change Reminder | 2 |
| | 1-459-00 | Mounting Screw | 2 |
| | 143495 | Lubricant, Silicone Packet | 1 |
| | 244796 | Drain Clamp, 3/8" QC | 1 |
| | 244797 | Inlet Adaptor, 1/2" FIPS x 1/2" MIPS x 1/4" QC | 1 |
| | 244880 | Faucet Adaptor, 1/4" NPT x 3/8" QC | 1 |
| | 150646 | TDS Test Kit | 1 |
| 7 | 244849 | Tube, 3/8" OD Red - Faucet Drain | 1 |
| 8 | 244848 | Tube, 3/8" OD Blue - Permeate | 1 |
| 9 | 244794 | Tube, 1/4" OD White PE | 1 |
| 10 | 244850 | Tube, 1/4" OD Green | 1 |
| 11 | 244875 | Tube, 1/4" OD Red | 1 |
| 12 | 357486 | Head Assembly Includes Bracket, Screws, Manifold Assembly and Plastic Tee | 1 |
| | 247181 | Manual, PB5RO (Not Shown) | 1 |

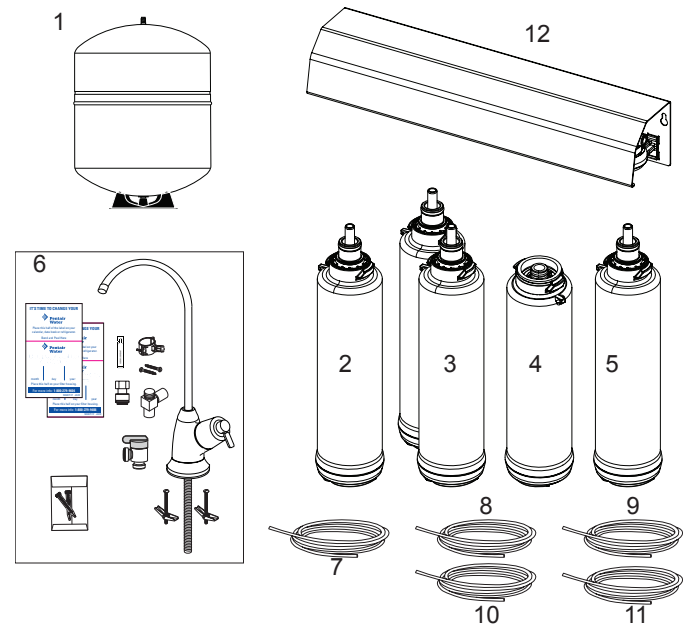

Arsenic Fact Sheet

Arsenic (abbreviated As) is found naturally in some well water. Arsenic in water has no color, taste or odor. It must be measured by a lab test. Public water utilities must have their water tested for arsenic. You can get the results from your water utility. If you have your own well, you can have the water tested. The local health department or state environmental health agency can provide a list of certified labs. The cost is typically \$15 to \$30. Information about arsenic in water can be found on the Internet at the US Environmental Protection Agency web site: www.epa.gov/safewater/arsenic.html.

There are two forms of arsenic: pentavalent arsenic [also called As(V), As(+5), and arsenate] and trivalent arsenic [also called As(III), As(+3) and arsenite]. In well water, arsenic may be pentavalent, trivalent, or a combination of both. Special sampling procedures are needed for a lab to determine what type and how much of each type of arsenic is in the water. Check with the labs in your area to see if they can provide this type of service.

Reverse osmosis (RO) water treatment systems do not remove trivalent arsenic from water very well. RO systems are very effective at removing pentavalent arsenic. A free chlorine residual will rapidly convert trivalent arsenic to pentavalent arsenic. Other water treatment chemicals such as ozone and potassium permanganate will also change trivalent arsenic to pentavalent arsenic. A combined chlorine residual (also called chloramine) may not convert all the trivalent arsenic. If you get your water from a public water utility, contact the utility to find out if free chlorine or combined chlorine is used in the water system.

The PB5RO-75 system is designed to remove pentavalent arsenic. It will not convert trivalent arsenic to pentavalent arsenic. The system was tested in a lab. Under those conditions, the system reduced 0.30 mg/L (ppm) pentavalent arsenic to 0.010 mg/L (ppm) (the USEPA standard for drinking water) or less. The performance of the system may be different at your installation. Have the treated water tested for arsenic to check if the system is working properly.

The RO component of the PB5RO-75 system must be replaced every 12-24 months to ensure the system will continue to remove pentavalent arsenic. The component identification and locations where you can purchase the component are listed in the installation/operation manual.

Performance Data

Important Notice: Read this performance data and compare the capabilities of this system with your actual water treatment needs. It is recommended that before installing a water treatment system, you have your water supply tested to determine your actual water treatment needs.

This system has been tested according to NSF/ANSI 58 for the reduction of the substances listed below. The concentration for the indicated substances in water entering the system was reduced to a concentration less than or equal to the permissible limit for water leaving the system, as specified in NSF/ANSI 58.

NOTE: Substances that may be reduced are not necessarily in your water. Filter must be maintained according to manufacturer's instructions, including replacement of filter cartridges.

The tested efficiency rating for this system is 15.80%. Efficiency rating means the percentage of the influent water to the system that is available to the user as reverse osmosis treated water under operating conditions that approximate typical daily usage. The tested recovery rating is 27.40%. Recovery rating means the percentage of the influent water to the membrane portion of the system that is available to the user as reverse osmosis treated water when the system is operated without a storage tank or when the storage tank is bypassed.

PB5RO-75

| Substance | Influent Challenge Concentration | Maximum Permissible Product Water Concentration | Reduction Requirements | Average Reduction |
|------------------------|----------------------------------|---|------------------------|-------------------|
| Standard 58 | | | | |
| Arsenic V | 0.050 mg/L ± 10% | 0.010 mg/L | | 97.6% |
| Barium | 10.0 mg/L ± 10% | 2.0 mg/L | | 96.7% |
| Cadmium | 0.03 mg/L ± 10% | 0.005 mg/L | | 98.2% |
| Chromium III | 0.3 mg/L ± 10% | 0.1 mg/L | | 97.6% |
| Chromium VI | 0.3 mg/L ± 10% | 0.1 mg/L | | 97.0% |
| Copper | 3.0 mg/L ± 10% | 1.3 mg/L | | 98.8% |
| Cysts | Minimum 50,000/mL | | 99.95% | 99.99% |
| Fluoride | 8.0 mg/L ± 10% | 1.5 mg/L | | 96.2% |
| Lead | 0.15 mg/L ± 10% | 0.010 mg/L | | 99.0% |
| Radium 226/228 | 27pCi/L ± 10% | 5pCi/L | | 80% |
| Selenium | 0.10 mg/L ± 10% | 0.05 mg/L | | 98.0% |
| Total Dissolved Solids | 750 mg/L ± 40 mg/L | 187 mg/L | | 94.9% |
| Turbidity | 11 mg/L ± 1 NTU | 0.5 NTU | | 99.1% |
| Standard 42 | | | | |
| Chlorine | 2 mg/L | | >=50% | 93.0% |

Production Rate: 24.83 gpd



The PB5RO-75 is Tested and Certified by NSF International against NSF/ANSI Standard 42 and 58 for the reduction of substances listed in the table above.

Testing was performed under standard laboratory conditions, actual performance may vary.

State of California
Department of Public Health
Water Treatment Device
Certificate Number
11 - 2098
Date Issued: October 24, 2011

Trademark/Model Designation

Pentair Water PB5RO-75

Replacement Elements

PW-RO75R (RO Membrane)
PW-S2500R (Pre Filters)
PW-C5000R (Pre Filters)
PW-C5000R (Pre Filters)
PW-C2500R (Post Filter)

Manufacturer: Pentair Residential Filtration, LLC

The water treatment device(s) listed on this certificate have met the testing requirements pursuant to Section 116830 of the Health and Safety Code for the following health related contaminants:

Microbiological Contaminants and Turbidity

Cysts
Turbidity

Organic Contaminants

None

Inorganic/Radiological Contaminants

Arsenic (pentavalent)¹
Barium
Cadmium
Chromium (hexalent)
Chromium (trivalent)
Copper
Fluoride
Lead
Radium 226/228
Selenium

Rated Service Capacity: 1250 gal service cycle

Rated Service Flow: 24.8 gpd

Conditions of Certification:

Do not use where water is microbiologically unsafe or with water of unknown quality, except that systems certified for cyst reduction may be used on disinfected waters that may contain filterable cysts.

¹ Claims for arsenic reduction shall only be made on water supplies maintaining detectable residual free chlorine at the reverse osmosis (RO) system inlet. Water systems using an in-line chlorinator should provide a minimum of 1 minute chlorine contact time before the RO system.

Pentair Residential Filtration, LLC LIMITED WARRANTY

Pentair Residential Filtration, LLC warrants to the original owner (under normal use): Reverse Osmosis System to be free from defects in material and/or workmanship one (1) year from the date of purchase. Any replacement products furnished will be free from defects in material and/or workmanship for the remainder of the original warranty period. This warranty does not cover: (1) pre and post filter cartridges, or reverse osmosis membrane (2) defects not reported within the above time period, (3) items manufactured by other companies, (4) problems arising from failure to comply with Pentair Residential Filtration, LLC instructions, (5) problems and/or damage arising from acts of nature, abuse, misuse, negligence or accident by any party other than Pentair Residential Filtration, LLC, (6) problems and/or damage resulting in whole or in part from alteration, modification, repair or attempted alteration, modification or repair by any party other than Pentair Residential Filtration, LLC, (7) noncompliance with applicable codes/ordinances.

If a defect in workmanship and/or material in a product or part covered by the warranty should arise, Pentair Residential Filtration, LLC, at its sole discretion, will repair or replace the defective product or part (Pentair Residential Filtration, LLC may consider, in good faith, the customer's preference).

All claimed defective product must: (1) be authorized for return by Pentair Residential Filtration, LLC with an RGA number (2) include proof of the purchase date of the product or part (3) returned to Pentair Residential Filtration, LLC prior to the expiration of the warranty date, at the customer's expense, shipment pre-paid, (4) be accompanied by a letter detailing the Model Number, Serial Number (if any), and a brief description of the problem.

TO THE MAXIMUM EXTENT PERMITTED BY APPLICABLE LAW, PENTAIR RESIDENTIAL FILTRATION, LLC DISCLAIMS ALL OTHER WARRANTIES, WHETHER EXPRESS OR IMPLIED, INCLUDING, BUT NOT LIMITED TO, THE IMPLIED WARRANTY OF MERCHANTABILITY AND FITNESS FOR A PARTICULAR PURPOSE, WITH REGARD TO THE PRODUCTS, PARTS AND ANY ACCOMPANYING WRITTEN MATERIALS.

To the maximum extent permitted by applicable law, Pentair Residential Filtration, LLC shall not be liable for any damages whatsoever (including, but not limited to, loss of time, inconvenience, expenses, labor or material charges incurred in connection with the removal or replacement of the system, special, incidental, consequential, or indirect damages for personal injury, loss of business profits, business interruption, loss of business information, or any other pecuniary loss) arising out of the use of or inability to use the defective products or parts, even if Pentair Residential Filtration, LLC has been advised of the possibility of such damages.

Pentair Residential Filtration, LLC'S maximum liability under any provision of this Limited Warranty shall be limited to the amount actually paid for the system.

NOTE: Because some states do not allow the exclusion or limitation of incidental or consequential damages, the above limitations or exclusions may not apply.

THIS WARRANTY GRANTS SPECIFIC LEGAL RIGHTS, AND OTHER RIGHTS MAY APPLY. SUCH RIGHTS VARY FROM STATE TO STATE.

Buyer

Seller

Date

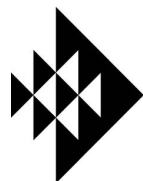

Pentair
Water

5730 North Glen Park Road, Milwaukee, WI 53209
Technical Support: 800.279.9404
www.pentairqua.com/pro