

Service Manual

Humidifying Air Purifier
HongKong/Mongolia Market
F-VXH50H

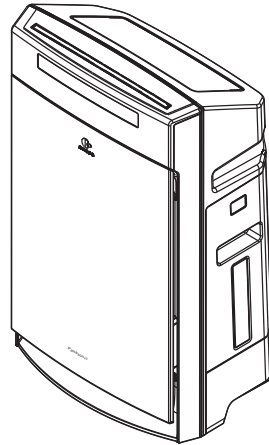

! WARNING

This service information is designed for experienced repair technicians only and is not designed for use by the general public. It does not contain warnings or cautions to advise non-technical individuals of potential dangers in attempting to service a product. Products powered by electricity should be serviced or repaired only by experienced professional technicians. Any attempt to service or repair the product or products dealt with in this service information by anyone else could result in serious injury or death.

IMPORTANT SAFETY NOTICE

There are special components used in this equipment which are important for safety. These parts are marked by **!** in the Schematic Diagrams, Exploded Views and Replacement Parts List. It is essential that these critical parts should be replaced with manufacturer's specified parts to prevent shock, fire or other hazards. Do not modify the original design without permission of manufacture. We suggest to handle such parts after the static electricity prevention. It is forbidden to touch the PCB parts by bare hands during the repairing process.

CONTENTS

	PAGE
1. Specifications	1
2. Parts Identification	2~5
3. Wiring Diagram	6
4. Parts List	7~10

1. Specifications

Model number	F-VXH50H					
Power supply	220V~ 50Hz					
Operation mode	Clean Air			Clean/Humid.		
Air Volume settings	Hi	Med	Lo	Hi	Med	Lo
Power Consumption (W) ※1	45	9	6	45	13	9
Humidifying amount (mL/h) ※2	— ※3	— ※3	— ※3	500	230	150
Air Volume (m ³ /min)	5.1	1.9	0.9	4.9	2.3	1.3
Floor area capacity	Up to 40m ² in a standard household room			Up to 23m ² in a standard household room		
Capacity of the tank	About 2.3L					
Power cord length	2.0m					
Product dimensions	360mmx [230mm+(Foot:10mm)]x560mm(WDXH)					
Product weight	8.6kg					

※1 The power consumption is about 0.3 W when the operation is set to "Off".(With the power plug inserted)

※2 The humidifying amount may vary with the indoor temperature and humidity.(Please refer to operating Instructions P.22)

※3 If there is water in the tank, the unit uses its water to humidify a little.(The water in the tank will be reduced little)

2. Parts Identification

F-VXH50H

Main Body Section

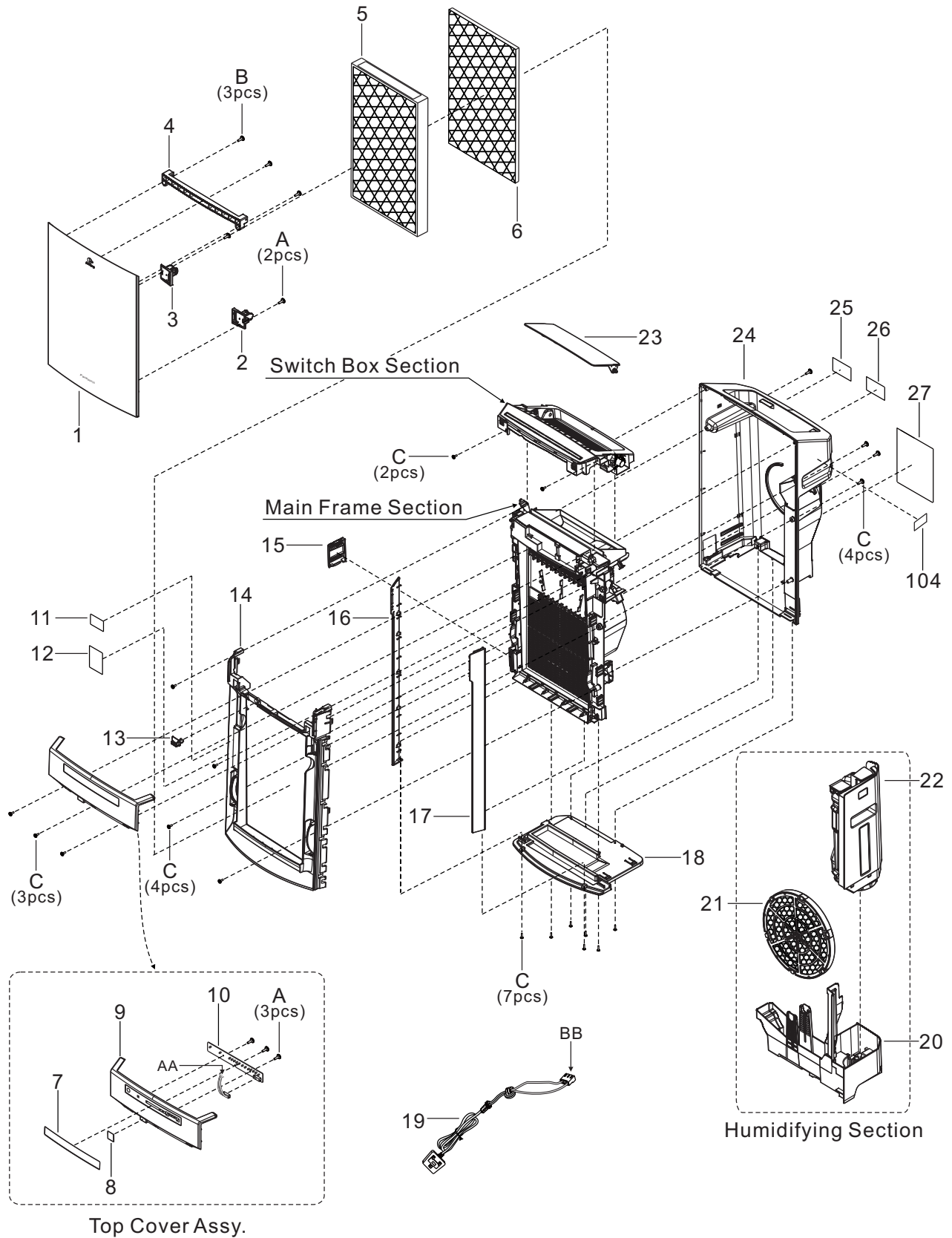

Remark: The double same letter which displayed behind the Lead Assy. Means they were linked together.

2. Parts Identification

F-VXH50H

Main Frame Section

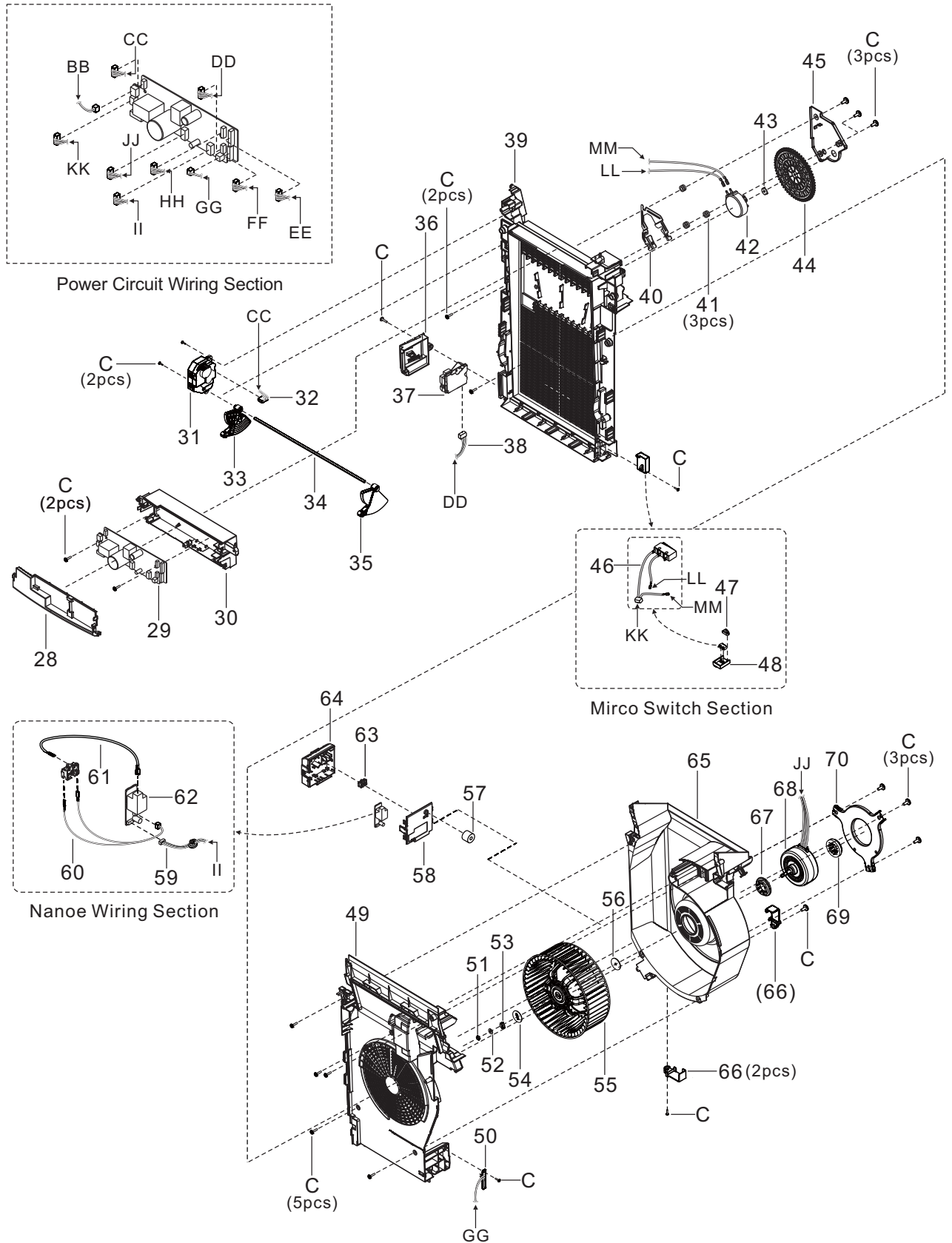

Remark: The double same letter which displayed behind the Lead Assy. Means they were linked together.

2. Parts Identification

F-VXH50H

Switch Box Section

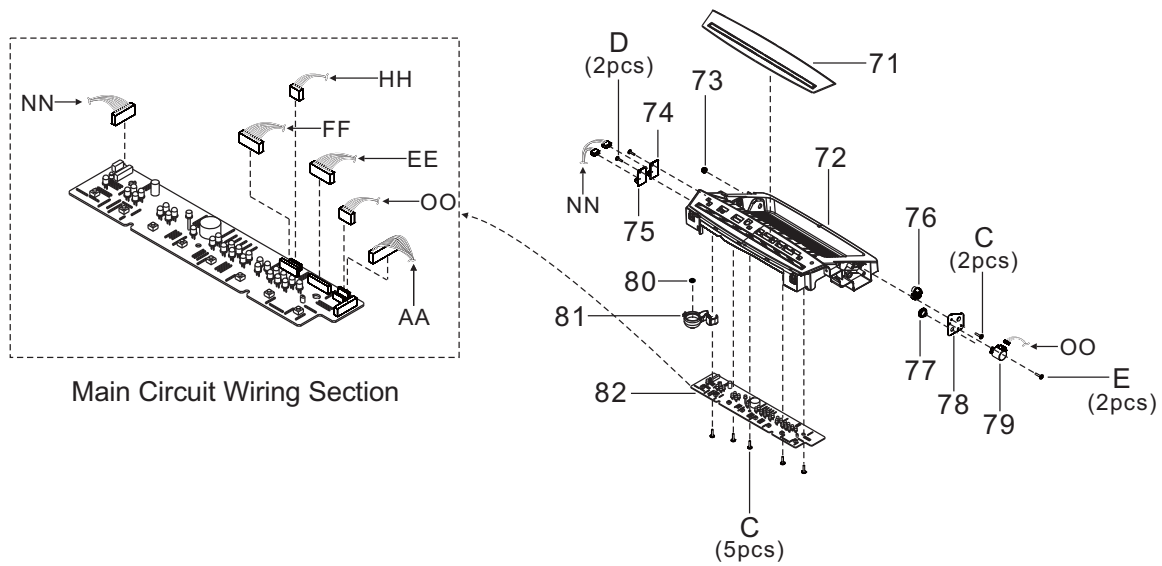

Humidifying Section

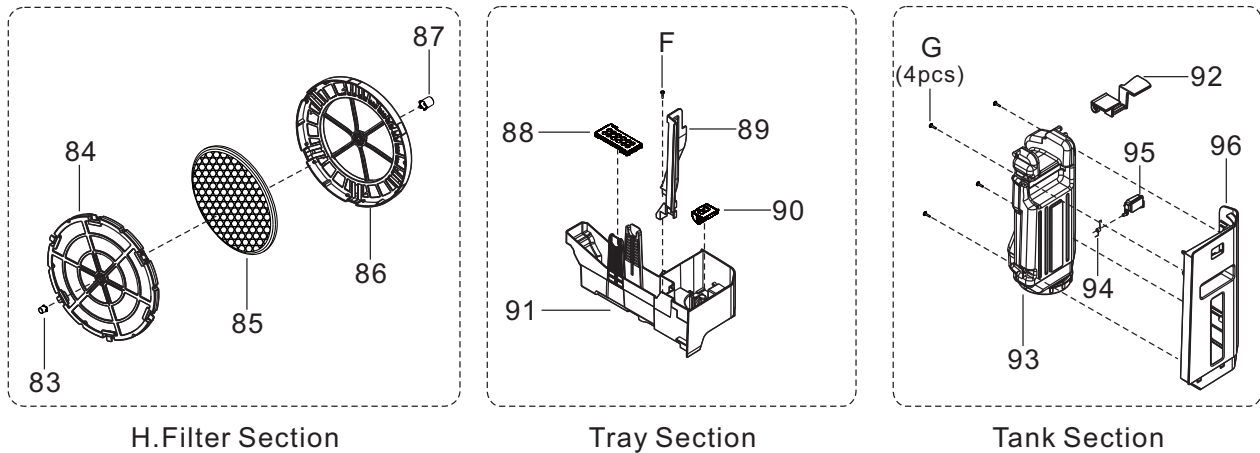

Remark: The double same letter which displayed behind the Lead Assy. Means they were linked together.

2. Parts Identification

F-VXH50H

Packing Section

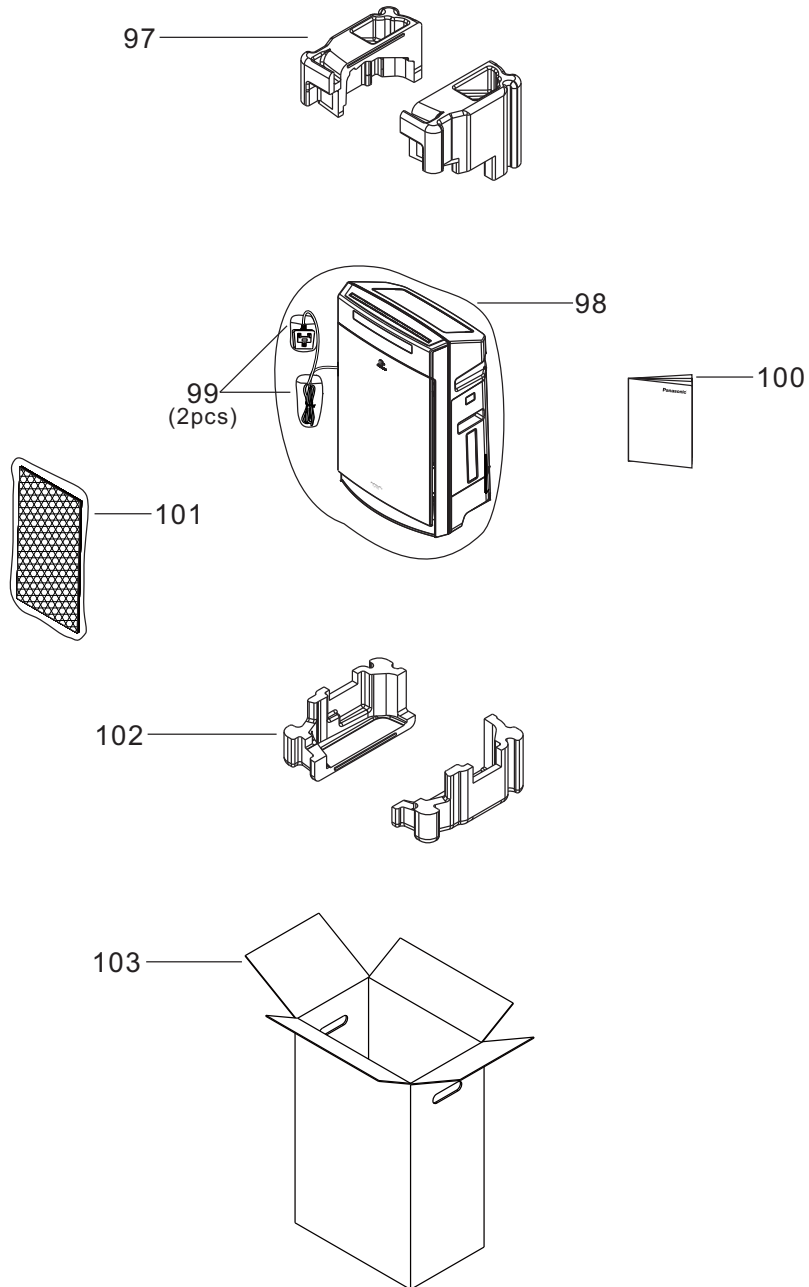

Remark: The double same letter which displayed behind the Lead Assy. Means they were linked together.

3. Wiring Diagram

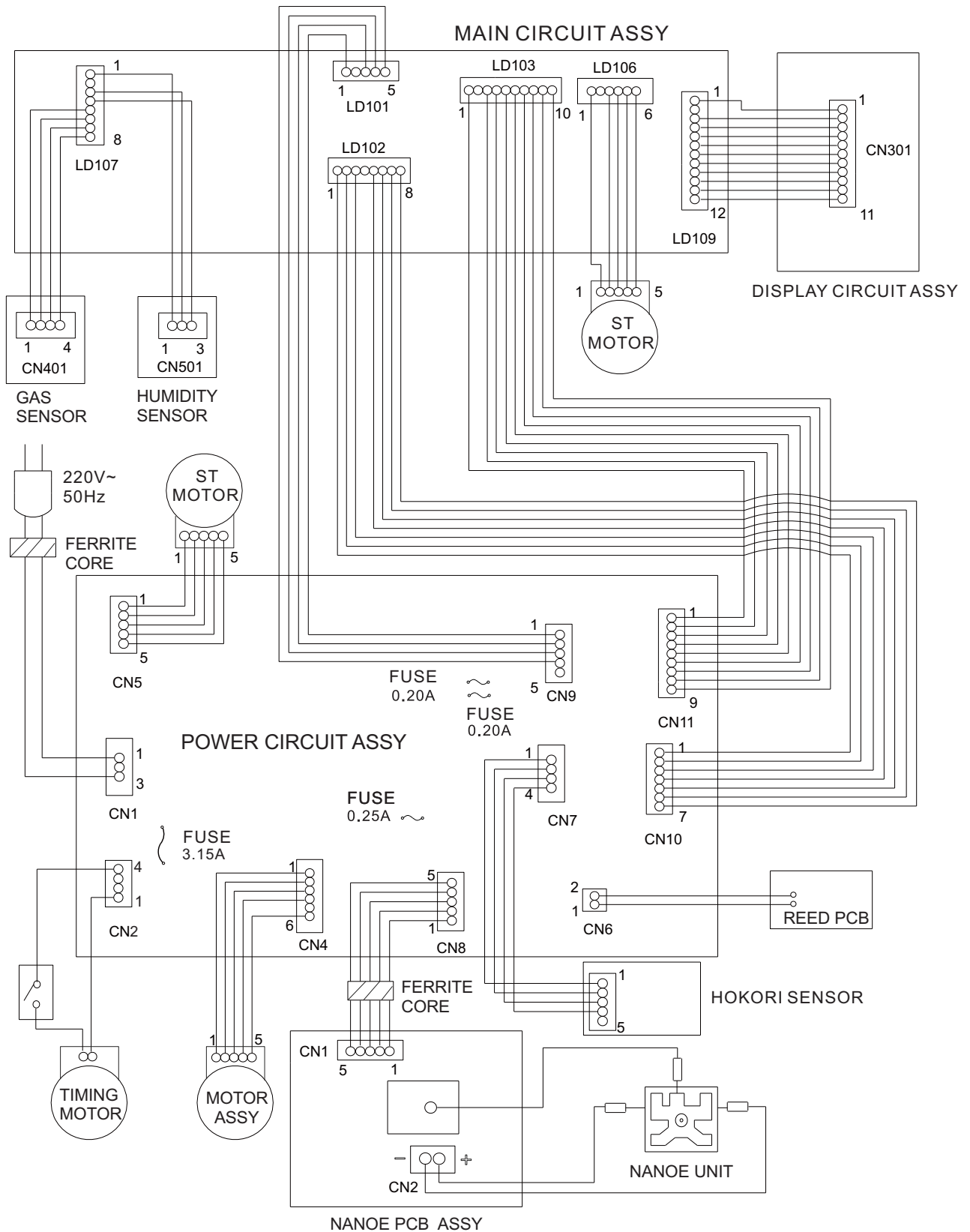

F-VXH50H



4. Parts List

F-VXH50H

Main Body Section

No.	Part No.	Part Name	Q'ty	Remark
1	FFE01201205S	F.Panel Stamping	1	For White Model
(1)	FFE01201601S	F.Panel Stamping	1	For Black Model
(1)	FFE01201602S	F.Panel Stamping	1	For Silver Model
2	FFE03041201S	Fixed Arm R	1	
3	FFE03031201S	Fixed Arm L	1	
4	FFE03051201S	Arm Holder	1	
5	FFE41801712S	C.Filter Assy.	1	
6	FFE41701708S	D.Filter Assy.	1	
7	FFE01161201S	Clean Sign Sheet	1	For White Model
(7)	FFE01161301S	Clean Sign Sheet	1	For Black Model
(7)	FFE01161302S	Clean Sign Sheet	1	For Silver Model
8	FFE00741201S	Filter Hook Label	1	For White/Silver Model
(8)	FFE00741601S	Filter Hook Label	1	For Black Model
9	FFE01071205S	Top Cover	1	For White Model
(9)	FFE01071301S	Top Cover	1	For Black Model
(9)	FFE01071601S	Top Cover	1	For Silver Model
10	FFE49301404S	Display PCB	1	
11	FFE00791204S	Brand Label	1	For White/Silver Model
(11)	FFE00791601S	Brand Label	1	For Black Model
12	FFE00771201S	Filter Label	1	For White/Silver Model
(12)	FFE00771601S	Filter Label	1	For Black Model
13	FFE01221201S	Filter Hook	1	
14	FFE01021201S	Front Case	1	For White Model
(14)	FFE01021301S	Front Case	1	For Black Model
(14)	FFE01021302S	Front Case	1	For Silver Model
15	FFE36400802S	D.Sensor Cover	1	For White/Silver Model
(15)	FFE36401301S	D.Sensor Cover	1	For Black Model
16	FFE04181201S	S.panel L Painting	1	For White Model
(16)	FFE04181301S	S.panel L Painting	1	For Black Model
(16)	FFE04181302S	S.panel L Painting	1	For Silver Model
17	FFE04191201S	S.panel R Painting	1	For White Model
(17)	FFE04191301S	S.panel R Painting	1	For Black Model
(17)	FFE04191302S	S.panel R Painting	1	For Silver Model
18	FFE01091201S	Stand	1	For White/Silver Model
(18)	FFE01091301S	Stand	1	For Black Model
19	FFE16001201S	Cord Assy.	1	
20	FFE00001201S	Tray Section	1	For White Model
(20)	FFE00001601S	Tray Section	1	For Black Model
(20)	FFE00001602S	Tray Section	1	For Silver Model
21	FFE00001202S	H.Filter Section	1	
22	FFE00001203S	Tank Section	1	For White Model
(22)	FFE00001603S	Tank Section	1	For Black Model
(22)	FFE00001604S	Tank Section	1	For Silver Model









4. Parts List

F-VXH50H

Main Body Section

No.	Part No.	Part Name	Q'ty	Remark
23	FFE04061201S	Top Louver	1	For White/Silver Model
(23)	FFE04061301S	Top Louver	1	For Black Model
24	FFE01101201S	Rear Case	1	For White/Silver Model
(24)	FFE01101302S	Rear Case	1	For Black Model
25	FFE00761204S	Notice Label	1	For White/Silver Model
(25)	FFE00761601S	Notice Label	1	For Black Model
26	FFE00751203S	Warning Label	1	For White/Silver Model
(26)	FFE00751601S	Warning Label	1	For Black Model
27	FFE00501204S	Name Plate	1	For White/Silver Model
(27)	FFE00501601S	Name Plate	1	For Black Model
104	FFE00780902S	Tank Label	1	For White/Silver Model
(104)	FFE00781601S	Tank Label	1	For Black Model
A	XTN35+8CFJ	Pan Tap Screw	5	
B	XTB4+10CFJ	Bind Tap Screw	3	
C	XTB4+14CFJ	Bind Tap Screw	20	







Main Frame Section

No.	Part No.	Part Name	Q'ty	Remark
28	FFE01131201S	PCB Cover	1	
29	FFE49101408S	Power Circuit Assy.	1	
30	FFE01111201S	PCB Box	1	
31	FFE00131201S	Gear Box Assy.	1	
32	FFE09031101S	STM Lead(GB)	1	
33	FFE03011101S	Arm L	1	
34	FFE01121201S	D Shaft	1	
35	FFE03021101S	Arm R	1	
36	FFE02091201S	D.Sensor Box	1	For White/Silver Model
(36)	FFE02091301S	D.Sensor Box	1	For Black Model
37	FFE12500601S	Dust Sensor	1	
38	FFE09021201S	D.Sensor Lead	1	
39	FFE01101202S	Main Frame	1	
40	FFE02101202S	TM Plate	1	
41	FFE02111201S	TM Gum	3	
42	FFE60001101S	Timing Motor	1	
43	FFE21101101S	Gear Stay	1	
44	FFE02061101S	Gear	1	
45	FFE02051201S	TM Cover	1	
46	FFE12901201S	Micro Switch Assy.	1	
47	FFE35500501S	Switch Lever	1	
48	FFE12500901S	Micro Switch Cover	1	
49	FFE02021201S	Casing Cover	1	
50	FFE49701403S	Reed PCB	1	
51	FFE07201101S	Hexagon Nut	1	
52	FFE06090801S	Undee Washer	1	





4. Parts List

F-VXH50H

Main Frame Section

No.	Part No.	Part Name	Q'ty	Remark
53	FFE21100803S	Blade Fix Ring	1	
54	FFE20050801S	Blade Plate(A)	1	
55	FFE02041101S	Blade Assy.	1	
56	FFE20030902S	Blade Plate	1	
57	FFE02091001S	Nanoe Silencer	1	
58	FFE02081201S	Nanoe Cover	1	
59	FFE09051201S	Nanoe Lead	1	
60	FFE09071201S	Peltier Lead	1	
61	FFE09061201S	High Voltage Lead	1	
62	FFE48041201S	Nanoe PCB Assy.	1	
63	FFE15001101S	Nanoe Unit	1	
64	FFE02071201S	Nanoe Case	1	
65	FFE02011201S	Fan Casing	1	
66	FFE02000801S	Ferrite Hold	2	
67	FFE08110801S	Holder Gum(A)	1	
68	FFE23001201S	Motor Assy.	1	
69	FFE08120801S	Holder Gum(B)	1	
70	FFE08010801S	Motor Holder	1	
C	XTB4+14CFJ	Bind Tap Screw	22	

Switch Box Section

No.	Part No.	Part Name	Q'ty	Remark
71	FFE04161201S	Display Sheet	1	For White Model
(71)	FFE04161301S	Display Sheet	1	For Black Model
(71)	FFE04161302S	Display Sheet	1	For Silver Model
72	FFE04011201S	Switch Box	1	For White/Silver Model
(72)	FFE04011301S	Switch Box	1	For Black Model
73	FFE21300801S	Louver Bush	1	
74	FFE49401405S	Humidity Sensor	1	
75	FFE49501403S	Gas Sensor	1	
76	FFE04071101S	Louver Gear	1	
77	FFE04081101S	STM Gear	1	
78	FFE04091101S	STM Holder	1	
79	FFE24001101S	ST Motor	1	
80	FFE05070901S	Hall IC Magnet	1	
81	FFE13011201S	Hall Case	1	
82	FFE49201408S	Main Circuit Assy.	1	
C	XTB4+14CFJ	Bind Tap Screw	7	
D	XTB3+14CFJ	Bind Tap Screw	2	
E	XSB4+6FJ	Bind Screw	2	For Fixing ST Motor

4. Parts List

F-VXH50H

Humidifying Section

No.	Part No.	Part Name	Q'ty	Remark
83	FFE06061201S	Cap(B)	1	
84	FFE06031201S	H.Filter Cover	1	
85	FFE06131705S	H.Filter Set	1	
86	FFE06021201S	H.Filter Case	1	
87	FFE06051201S	Cap(A)	1	
88	FFE05551201S	Germproof Set	1	
89	FFE05111201S	Tray Plate	1	For White/Silver Model
(89)	FFE05111301S	Tray Plate	1	For Black Model
90	FFE01181201S	Float Assy.	1	
91	FFE05101201S	Tray	1	For White/Silver Model
(91)	FFE05101301S	Tray	1	For Black Model
92	FFE06041101S	Tank Stand	1	
93	FFE05011201S	Tank Unit	1	
94	FFE01160801S	Handle Spring	1	
95	FFE06081201S	Tank Hook	1	
96	FFE05031201S	Tank Cover	1	For White/Silver Model
(96)	FFE05031301S	Tank Cover	1	For Black Model
F	XTB4+14CZ	Bind Tap Screw	1	For Fixing Tray Plate
G	XTT4+14CZ	Truss Tap Screw	4	For Fixing Tank Unit

Packing Section

No.	Part No.	Part Name	Q'ty	Remark
97	FFE80101203S	Top Pack	1	
98	FFE21310901S	Poly Cover	1	For Body Packing
99	FFE01110801S	Poly Cover	2	For Cord Assy.Packing
100	FFE89501203S	Operation Instructions	1	For Hong Kong Market
(100)	FFE89511602S	Operation Instructions	1	For Mongolia Market
101	FFE21371101S	Poly Cover	1	For D.Filter Assy. Packing
102	FFE80201201S	Bottom Pack	1	
103	FFE80011427S	Carton Case	1	For Hong Kong Market
(103)	FFE80011604S	Carton Case	1	For White Model,For Mongolia Market
(103)	FFE80011605S	Carton Case	1	For Black Model,For Mongolia Market
(103)	FFE80011606S	Carton Case	1	For Silver Model,For Mongolia Market