

OPUS™

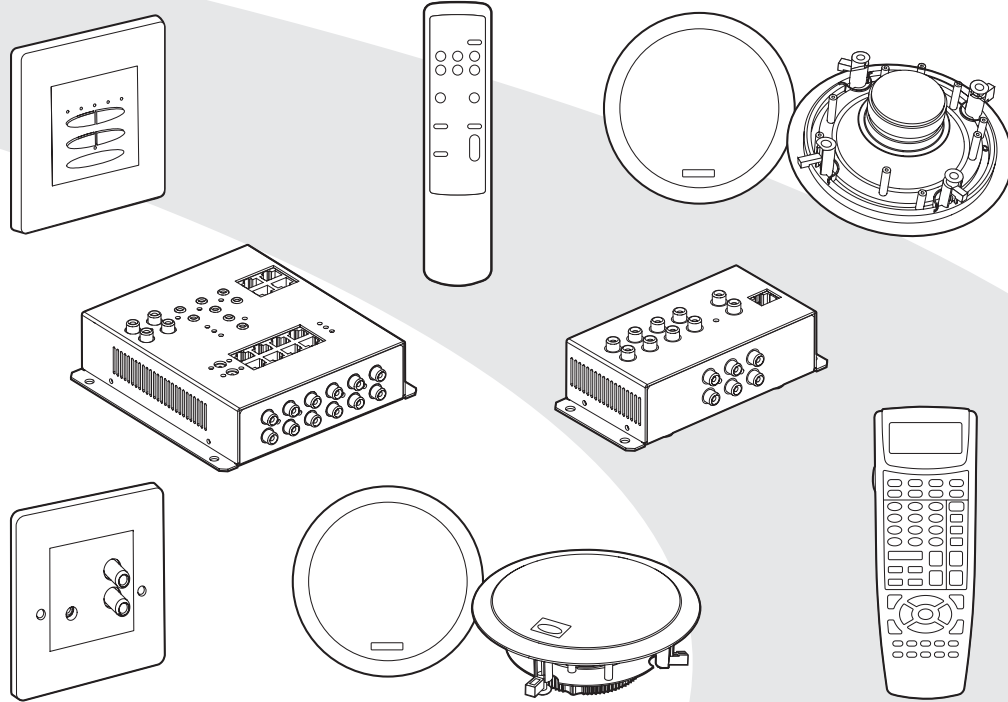

Opus 300 Multi-Room System

User Guide

La version française de ce manuel est disponible sur le site:

Eine deutsche Version der Bedienungsanleitung ist verfügbar unter:

La versión en español de este manual está disponible en:

La versione in lingua italiana di questo manuale è disponibile sul sito:

Een nederlandse versie van deze gebruiksaanwijzing is beschikbaar via:

Русская версия данного руководства находится по адресу:

نسخة العربية لهذا الكتيب متوفرة لدى:

www.opus.eu/manuals

Contents

| | |
|---|----|
| Opus 300 system component overview..... | 3 |
| WCU300 - Keypad functions..... | 4 |
| WCU300 - Keypad sound adjustment..... | 5 |
| Sound adjustment functions..... | 6 |
| SRC300 - System remote control..... | 7 |
| Adding your source equipment - Audio connections..... | 8 |
| LIM300 - Local source connections..... | 9 |
| LRC300 - Learning mode..... | 10 |
| FAQs..... | 11 |



Important safety warnings and precautions are included within the Installation Guide supplied with this system. Please ensure you read these. If you do not have a copy of this guide please ask your installer or dealer or download a copy at: www.opus.eu

Opus 300 system component overview

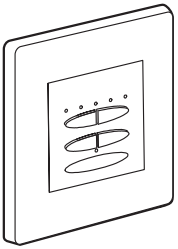

**WCU300
Wall Control Unit**
Keypad used to select and control sources connected to the MCU.

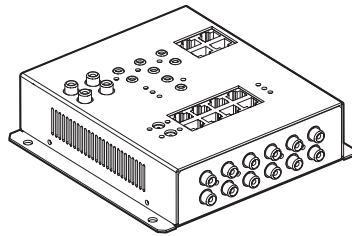

**MCU300
Master Control Unit**
Central control unit which connects to your audio sources and distributes them to the desired zones.

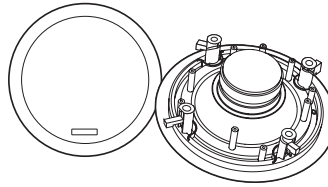

**OS165CC
Ceiling Speakers**
Ceiling mounted speaker pair.

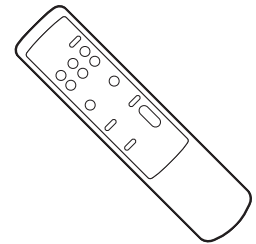

**SRC300
System Remote Control**
System remote control for everyday use in conjunction with the keypad.

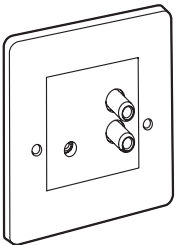

**LIM300
Local Input Module**
In-wall module that allows additional local sources to those distributed by the MCU (optional).

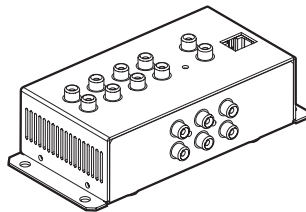

**VSU300
Video Switching Unit**
Distributes visual sources to zone screens (optional).

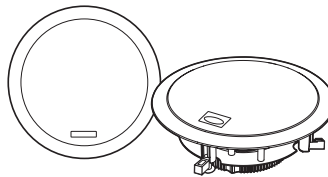

**AMR650
Active Ceiling Speakers**
Active and passive A-BUS® compatible ceiling mounted speaker pair.

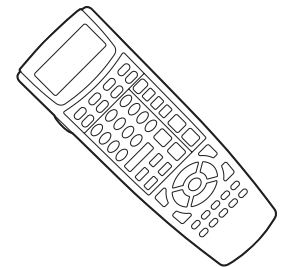

**LRC300
Learning Remote Control**
Learning remote for controlling source equipment and teaching infrared source commands to the MCU (see dedicated manual for operation).

WCU300 - Keypad functions

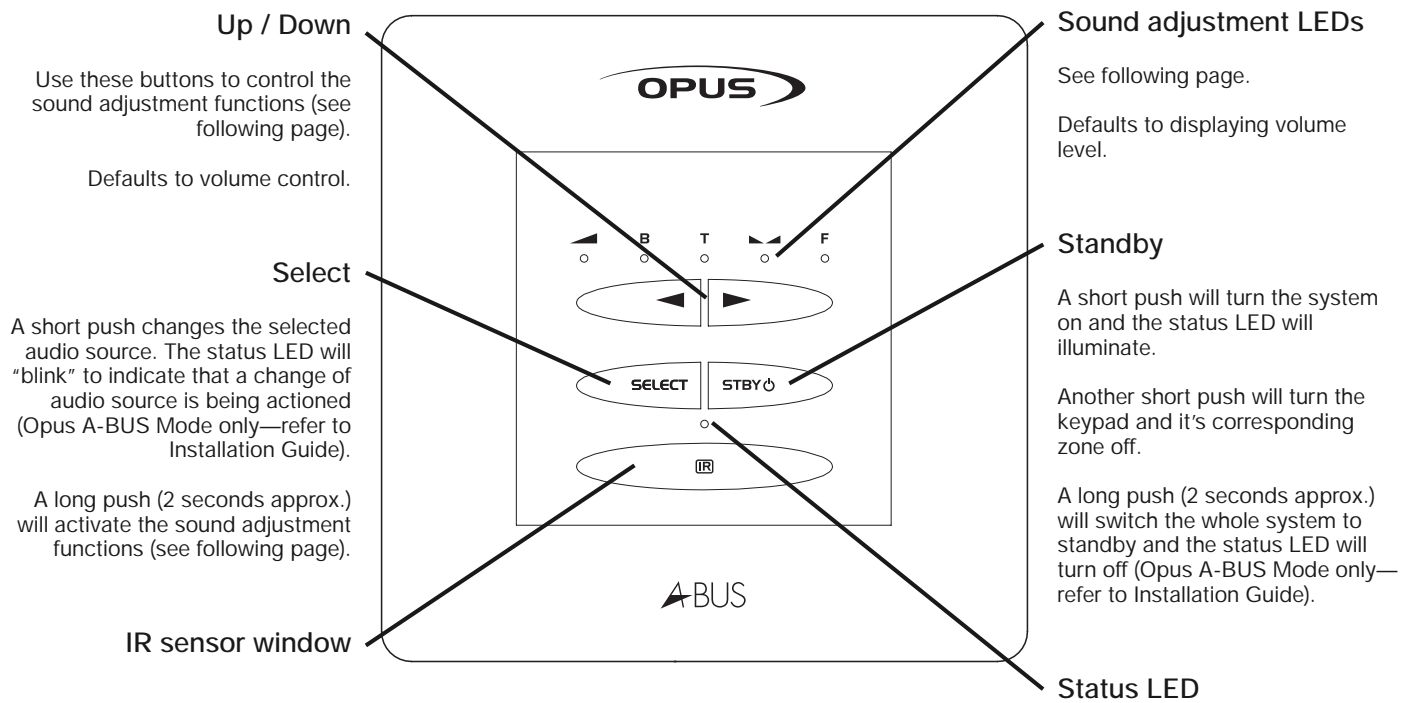

WCU300 - Keypad sound adjustment

The Up/Down buttons are used to adjust volume. To access the other sound adjustment functions below press and hold the Select button for approx two seconds:

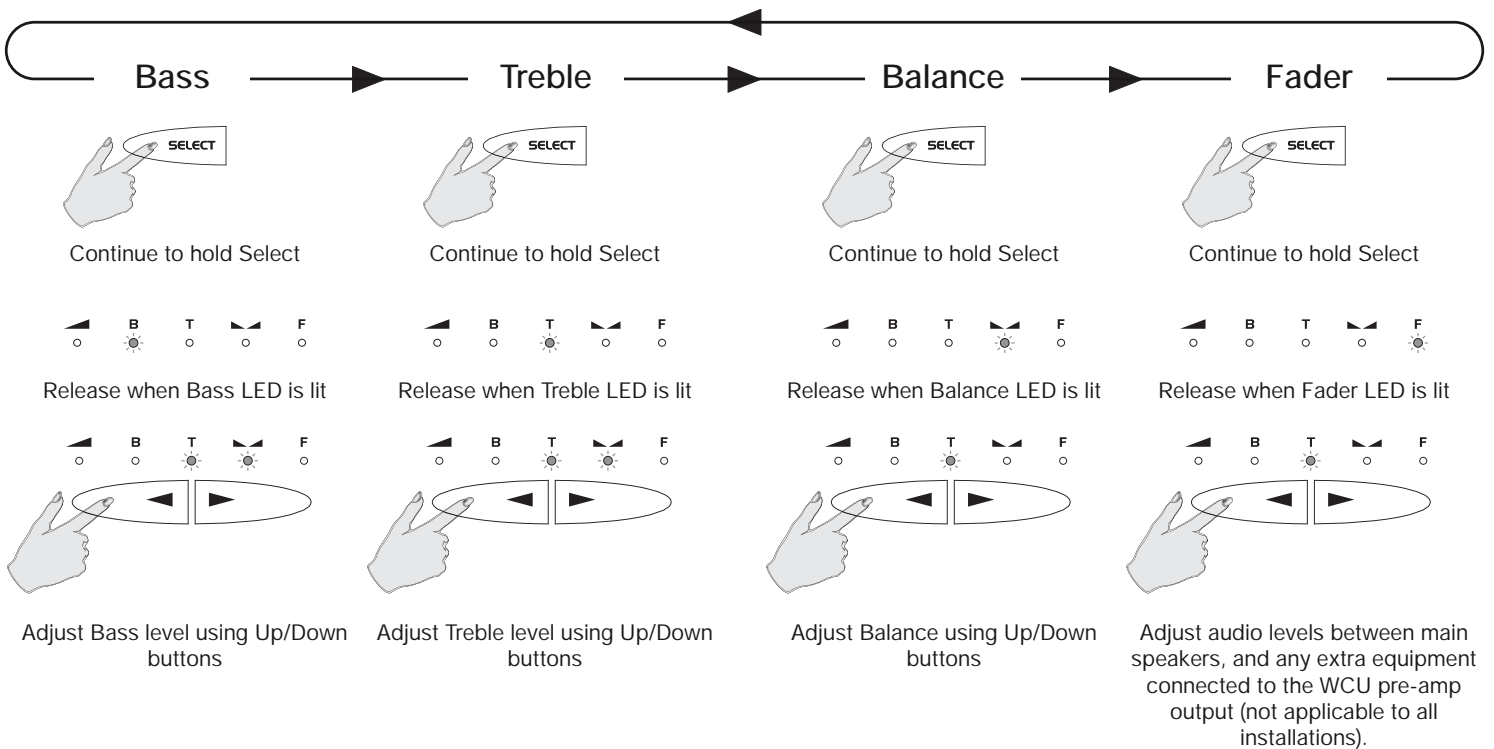

Note: If no action is taken for approximately two seconds the sound adjustment function will default to volume control.

Sound adjustment functions

For AMR650 Active Speaker only - press the Select button:

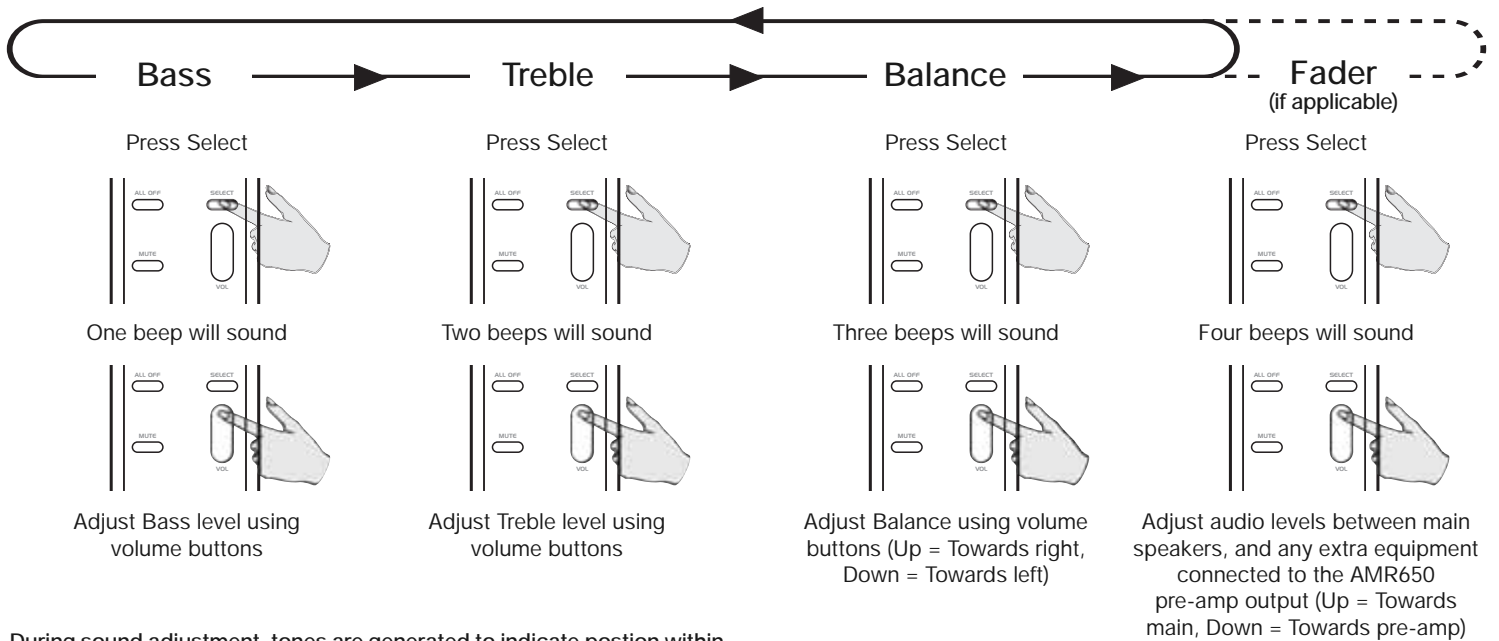

During sound adjustment, tones are generated to indicate position within the available range:

A single medium frequency tone indicates a neutral setting.

Two rising tones indicate the upper level of adjustment has been reached.

Two falling tones indicate the lower level of adjustment range has been reached.

SRC300 - System remote control

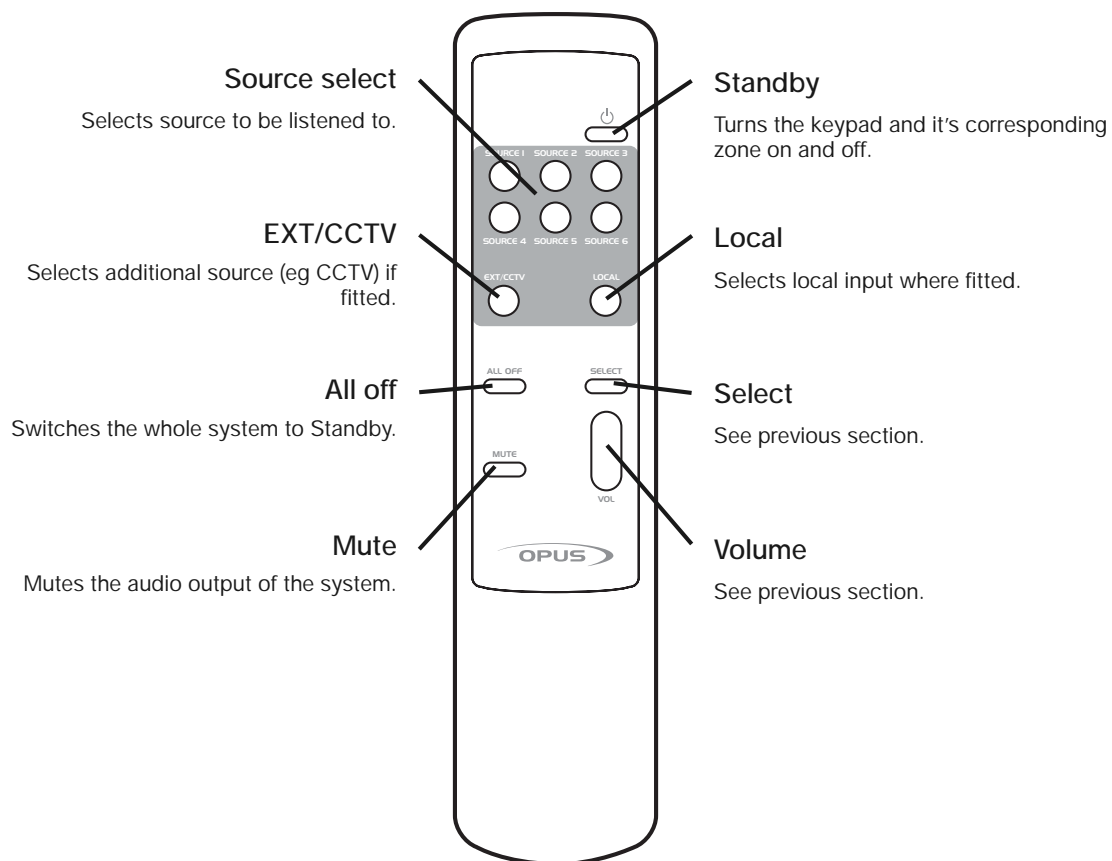

Adding your source equipment - Audio connections

Audio source equipment connections

Up to six pieces of audio source equipment can be connected to an MCU. Connections are made from the source equipments' audio outputs to the inputs on the MCU via RCA connections:

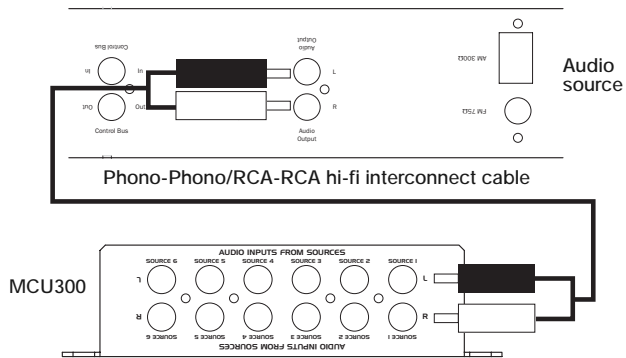

Remote control of source equipment through the WCU300

For remote control of the source equipment, 6 routed IR outputs are provided. Individual IR emitters are plugged into the appropriate IR output (corresponding to the respective Audio input). The other end is stuck to the IR receiving window of the source equipment:

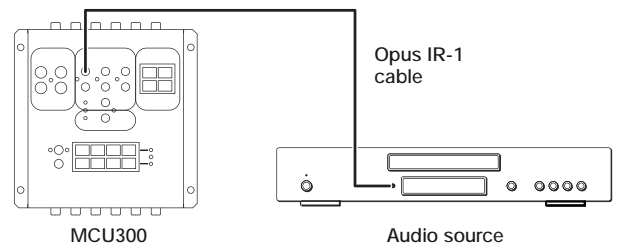

LIM300 - Local source connections

Note: Full details of installation, connection, operation and special features can be found in the guide that accompanies the LIM300 module.

The LIM300 Local Input Module (LIM) is an optional in-wall module that allows the user to add additional local sources to those distributed by the MCU300.

The local source may only be heard in the room where it is connected and the corresponding sub-zone (if connected), and is not distributed to other rooms. LIM300s can be fitted in as many rooms as are desired.

The LIM300 connects between the MCU300 audio hub and a WCU300 keypad using Cat-5/5e wiring. Each main zone can support two LIM300s, giving you the option of listening to one or two local sources (eg. Playstation, MP3 player). Each local source can be controlled through the Opus remote and/or keypad.

Note: The MCU300 and WCU300s must be in Opus A-BUS mode in order to use an LIM300.

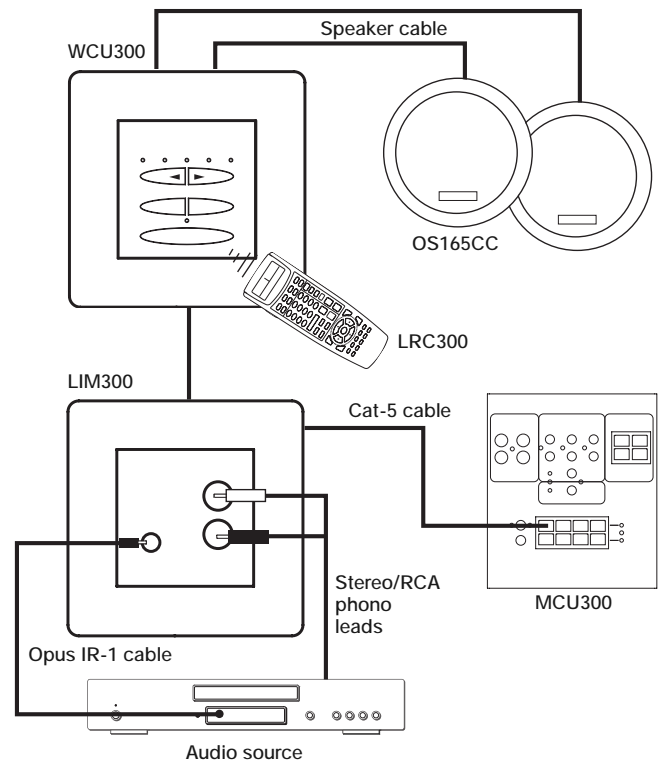

LRC300 - Learning mode

Note: Full details of operation and special features can be found in the guide that accompanies the LRC300 learning remote.

1. On the back of the remote press the LEARN button once to enter Learn mode (using a paperclip or similar). Display shows "LEARN" flashing.

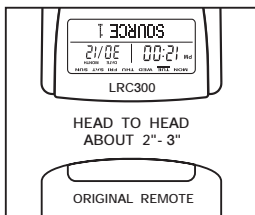
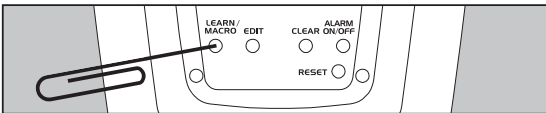

Place the original source remote (CD, DVD etc) facing the LRC300, head to head, about 2-3 inches (5-8 cm) apart.

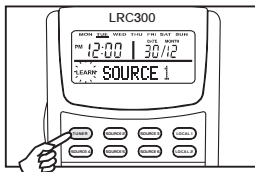

2. Press a device button (e.g. Source 1) to select the device bank into which you wish to teach codes.

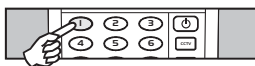

3. "LEARN" appears flashing on the display. Press the desired storage button (e.g. button 1). "LEARN" will stay static on the display.

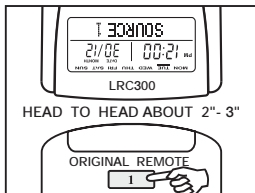

4. On the original remote, press and hold the button whose IR code you want to teach into the LRC300. Hold the button until the LRC300 display reads "OK!".

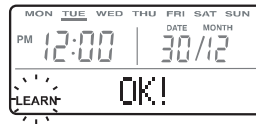

When "OK!" appears, learning is complete and "LEARN" flashes again. Repeat steps 3-4 to learn another button. If no storage button is pressed after 8 seconds, the remote will automatically select the next storage button for you.

Note: When the remote is scanning for a code to be learnt it is not possible to exit Learn mode or select a different storage button. Wait 8 seconds until the remote times out and "LEARN" begins flashing again.



If the display shows "ERROR", please ensure the correct steps are followed and repeat.



If the display shows "NO DATA", there was no signal from the original remote. Check the remotes are aligned, the original remote's batteries are good and repeat the process.

5. When finished press the LEARN button to exit Learn mode.

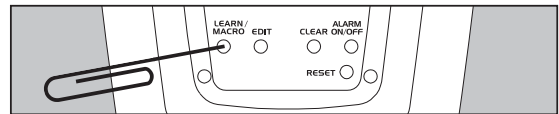

Note: It is NOT possible to teach new codes (or Macros) into the 6 dedicated Opus System buttons, as they are always needed to control the Opus keypads.

FAQs

1. What entertainment equipment can I connect?

The Opus 300 system is compatible with almost any type of hi-fi or video separate.

2. What is the difference between a main zone and a sub-zone?

A sub-zone can only listen to the same audio source as is being listened to in the main zone. The sub-zone has independent power, volume and tone controls from the main zone.

3. How many rooms can a system serve?

Each MCU300 supports 4 main + 4 sub-zones. 4 MCU's can be chained together supporting up to a maximum of 16 main zones and 16 sub-zones. If a larger system is required it is possible to have two or more separate systems running independently giving unlimited expandability.

4. Can I use any Cat-5e cable?

Any type of Cat-5e can be used.

5. Do I have to use Opus speakers?

No, but it is highly recommended as the Opus speakers are optimised and impedance matched to the keypad amplifiers.

6. How many remote controls can the system have?

There is no limit to the amount of remotes you can have. If required you can have a remote in each room.

7. What advice can you give for keypad location?

When locating a keypad you should avoid putting in direct sunlight or in close proximity to Plasma screens. Care should also be taken locating it near to devices that produce electrical noise such as mechanical dimmers. Positions of other wall controls/light switches should also be considered.

8. Is there a maximum cable run from MCU to each WCU?

Yes, the maximum cable run is 30 metres / 100 feet.

Information in this document has been carefully checked for accuracy; however, no guarantee is given to the correctness of the contents. The information in this document is subject to change without notice. If you notice any errors please feel free to email us at: info@opus.eu

Copyright

© Copyright Opus Technologies Ltd 2007

This document contains proprietary information protected by copyright. All rights are reserved.

No part of this manual may be reproduced by any mechanical, electronic or other means, in any form, without prior written permission of the manufacturer.

Trademarks

All trademarks and registered trademarks are the property of their respective owners.



A-BUS is a registered trademark of LeisureTech Electronics Pty Ltd.

This product may be covered by one of more of the following patents US 7,181,023 , 6,389,139, EP 1004222, AU 739808, NZ 502982, Mexico Z41196, Canada CA2301062.

Opus is committed to providing the highest levels of service and support. For full details of this product visit the Opus website:

www.opus.eu

Made from recyclable material
Part No. AP22968/1