



**OMNEX**  
TRUSTED WIRELESS™

# GENERIC 6SW

## Installation / Configuration Manual

### T150 Transmitter R130 Receiver

Revised May 23, 2006

Version 2

DMAN - xxxx - xx

#74-1833 Coast Meridian Road, Port Coquitlam, BC, Canada • V3C 6G5

Ph# (604) 944-9247 • Fax# (604) 944-9267

Toll Free 1-800-663-8806

# Table of Contents

|  |    |
|--|----|
| System Overview .....                      | 3  |
| Features .....                             | 3  |
| T150 Dimensions and Controls .....         | 3  |
| Installing the Receiver .....              | 4  |
| Anti 2 Block Wiring .....                  | 5  |
| Installation Considerations .....          | 5  |
| Power the Transmitter .....                | 6  |
| Test the Transmitter / Receiver Link ..... | 6  |
| Download ID Code .....                     | 7  |
| Calibrating Proportional Controls .....    | 9  |
| Diagnostics—T150 Transmitter .....         | 10 |
| Diagnostics—R130 Receiver .....            | 11 |
| Troubleshooting Guide .....                | 12 |
| Parts & Accessories .....                  | 16 |
| Specifications .....                       | 16 |
| Warranty Information .....                 | 16 |

**NOTE:** These instructions are intended only for installing and operating the remote control equipment described here. This is not a complete Operator's Manual. For complete operating instructions, please read the Operator's Manual appropriate for your particular machine.

## Safety Precautions

### READ ALL INSTRUCTIONS

**CAUTION:** Changes or modifications not expressly approved by the party responsible for compliance could void the user's authority to operate the equipment.

Failure to follow the SAFETY PRECAUTIONS may result in radio equipment failure and serious personal injury

#### Installation

PROVIDE A SAFETY CUTOFF SWITCH. If maintenance is required, the radio must be disconnected from power  
USE PROPER WIRING. Loose or frayed wires can cause system failure, intermittent operation, machine damage, etc.  
DO NOT INSTALL IN HOT AREAS. This apparatus can be damaged by heat in excess of 158° F (70° C)

#### Personal Safety

MAKE SURE MACHINERY AND SURROUNDING AREA IS CLEAR BEFORE OPERATING. Do not activate the remote system unless it is safe to do so.

TURN OFF THE RECEIVER POWER BEFORE WORKING ON MACHINERY. Always disconnect the remote system before doing any maintenance to prevent accidental operation of the machine

#### Care

KEEP DRY. Do not clean the transmitter / receiver under high pressure. If water or other liquids get inside the transmitter battery or receiver compartment, immediately dry the unit. Remove the case and let the unit air dry

CLEAN THE UNIT AFTER OPERATION. Remove any mud, dirt, concrete, etc. from the unit to prevent clogging of buttons, switches, etc. by using a damp cloth.

#### Maintenance / Welding

DISCONNECT THE RADIO RECEIVER BEFORE WELDING on the machine the receiver is connected to. Failure to disconnect will result in the destruction of the radio receiver.

## System Overview

The **ORIGA T150 / R130** is a portable, long range, programmable radio remote control system. Designed as a compact and easy-to-use product, this member of the **ORIGA** family puts complete control of your crane where it's needed most, with the operator. It's robust, easy to install and has complete self-diagnostics. This system can be a simple cable replacement or add intelligence to make it a total crane control package. It's a radio, a PLC and a valve driver all in one.

The **ORIGA T150 / R130** system uses Frequency Hopping Spread Spectrum (FHSS) technology. FHSS devices concentrate their full power into a very narrow signal that randomly hops from frequency to frequency within a designated band. This transmission pattern, along with CRC-16 error-checking techniques, enables signals to overcome interference that commonly affects licensed radios.

The **R130 receiver** is designed to be powered from a 12VDC or 24VDC system. It features 4 solid state, high-side driver input / output controls and a reliable E-Stop control.

The **T150 transmitter** comes with 4 to 6 switches and an optional proportional trigger control. It uses standard, long lasting AA batteries. Each T150 transmitter uses a unique ID code to ensure that no two systems will conflict at a job site.

### Features

- FCC, ISC, CE approved
- License free
- 1200 foot range @ 900 MHz (900 ft. @ 2.4 GHz)
- Hand held / weatherproof / ergonomic
- Simple "wire-and-use" installation
- Resilient to impact and shock
- Available in both 900 MHz and 2.4 GHz
- Available with optional trigger for proportional control
- Available with E-Stop for ensured operator safety
- Available with an optional tether cable
- Factory configurable for all custom applications.



R130 Receiver

T150 Transmitter

### T150 Dimensions and Controls

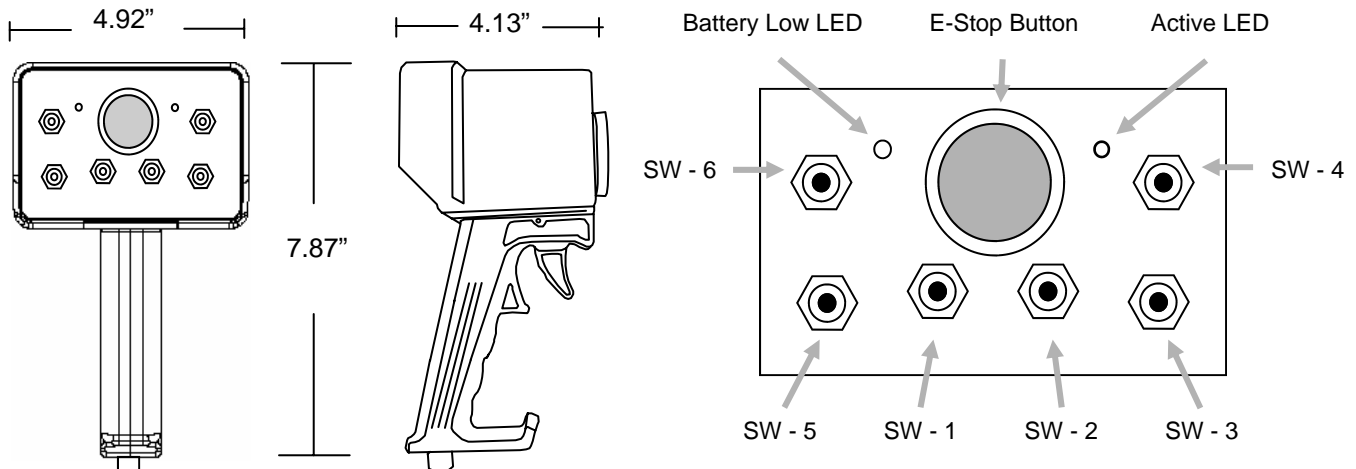

## Installing the Receiver

Use the **Wiring Diagram** and below to connect the receiver pins directly to the appropriate contacts of the machine electronics. R130 Output Cables can be provided with every system to simplify the wiring process. The Wire # column below only applies to the OMNEX Output Cable configuration. Tips on mounting, power connections and filtering are also provided under **Installation Considerations**.

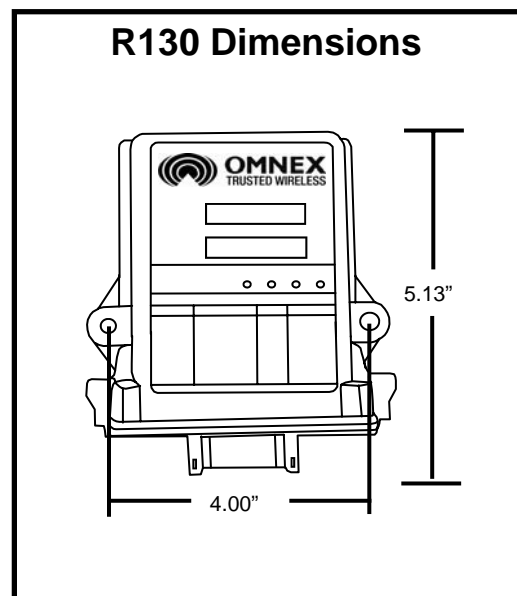
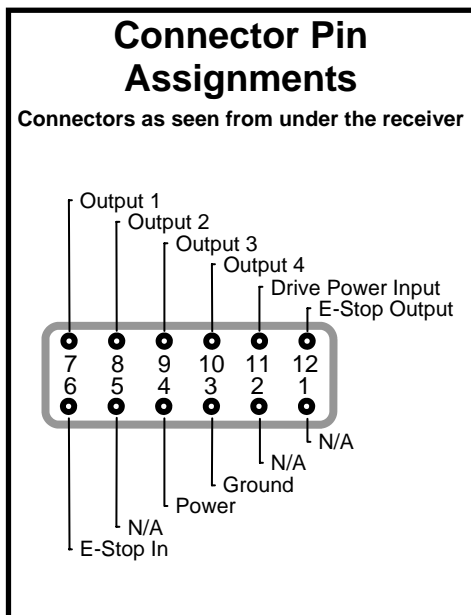
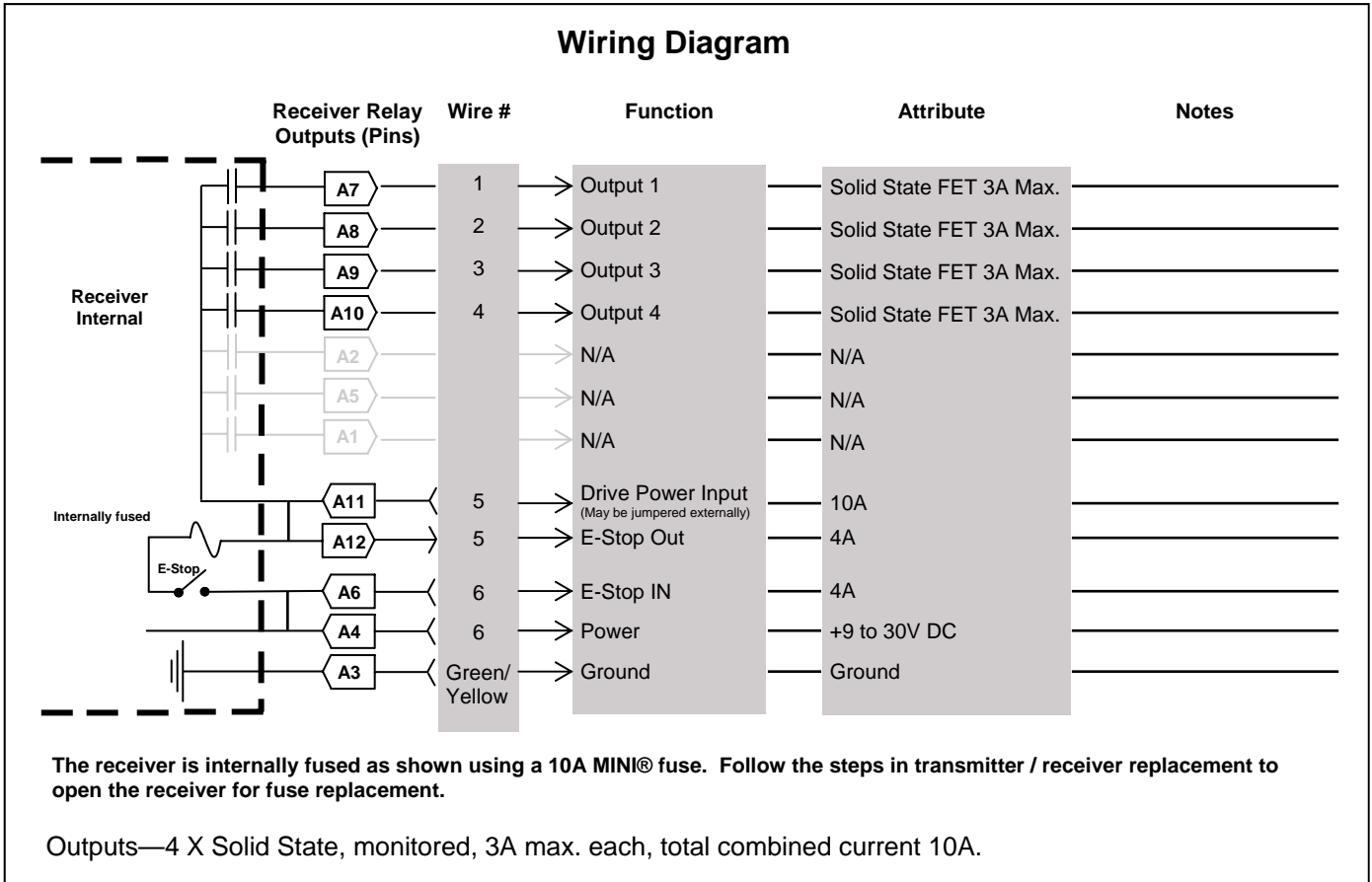

## Installation Considerations

**NOTE:** The FCC and ISC require that the antenna be restricted to that supplied by the manufacturer and approved for use with this product. An optional 0dB coax wire antenna may be supplied. For other antenna options, please contact OMNEX Control Systems ULC

### Mounting and Installation

The receiver can be mounted by fastening two ¼" bolts through the two mounting holes in the unit's enclosure. When mounting, ensure that the receiver is oriented so that the text is reading right and the connectors pointing "down".

**When selecting a mounting point for the receiver, it is recommended that the location require only a minimal length of wiring to connect it to the control panel, that it will be in a visible area where it has good exposure to the operator and that it is mounted on a surface that is protected from the weather and sustains minimal vibration. It is also recommended that the receiver have the best possible line of sight with the transmitter**

### Power Connections and Wiring

Whenever a power connection is made to an electronic device, it is a good practice to make both the Power (+) and Ground (-) connections directly to the Battery and avoid connecting the power from the charging side of existing wiring or making use of existing "ACC" or other peripheral connection points.

Make sure that wire of sufficient gauge and insulator type is used when connecting the outputs of the receiver to the control panel. Observe any component manufacturer's instructions and recommendations for proper integration of their product. This includes the power ratings and requirements of such components as relays, valves, solenoids, etc.

Be sure to test each of the outputs with a multi-meter prior to connecting the outputs to your end devices. This will ensure that each output has been programmed to operate in the manner required by each end device.

### Filtering and Noise Suppression

Whenever a solenoid or electromagnetic switch is controlled by the receiver, it is a good practice to install a Diode across its terminals to ensure that surges and spikes do not continue back into the circuit. Appropriate 36V Bi-directional Diodes kits can be ordered under the OMNEX part number "AKIT-2492-01".

## Power the Transmitter

When the receiver has been installed, install batteries into the transmitter and turn it on as explained below.



T150 Battery Housing

### 1. Install Batteries

Remove the battery cover on the back of the transmitter using a slotted screwdriver and insert 4 "AA" alkaline batteries. Orientation of the batteries is embossed inside the battery housing. No batteries are required when the transmitter is connected to the receiver by a Tether Cable.

**NOTE:** For operation at temperatures below  $-10^{\circ}\text{C}$  lithium batteries are recommended. Low temperatures reduce battery performance for both alkaline and lithium types. Refer to the battery manufacturer's specifications for detailed information on low temperature performance.

### 2. Turn on the Transmitter

Refer to the **Light Legend** below for diagram details.

**WARNING:** do not install batteries backwards, charge, put in fire, or mix with other battery types. May explode or leak causing injury. **Replace all batteries at the same time as a complete set and do not mix and match battery types.**

#### 1. Press [E-Stop]

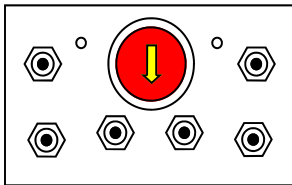

#### 2. Press any switch

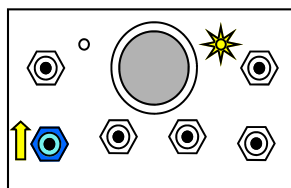

#### 3. Twist Clockwise & Release [E-Stop]

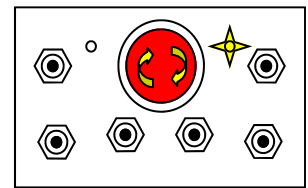

If the transmitter's (Active) light does not flash, check the battery orientation.

To turn off the transmitter, press the [E-Stop] button.

## Test the Transmitter / Receiver Link

Follow these steps to ensure that there is a radio link between the transmitter and receiver. Refer to the **Light Legend** below for diagram details

#### 1. Press [E-Stop]

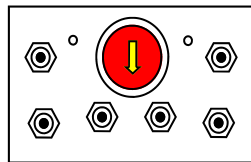

#### 2. Power the R130

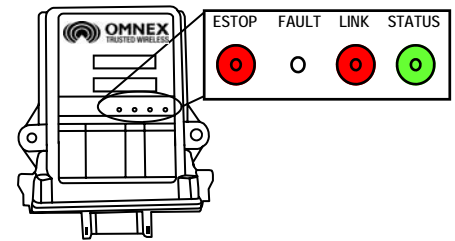

#### 3. Power the T150

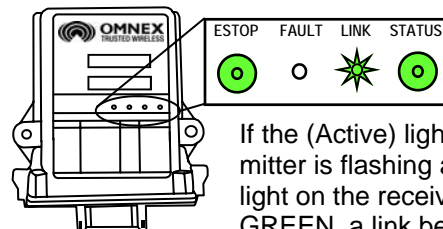
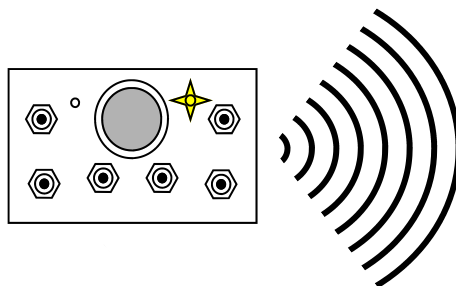

If the (Active) light on the transmitter is flashing and the (Link) light on the receiver is flashing GREEN, a link between the two exists.

If the receiver's (Link) light does not flash GREEN, follow the steps under **Download ID Code** below.

**The ORIGA system is now ready for use.**

| Light Legend | Solid | Slow Flash | Fast Flash | Red Light | Green Light | Yellow Light | Alternating Red & Green Light |
|--------------|-------|------------|------------|-----------|-------------|--------------|-------------------------------|
|              |       |            |            |           |             |              |                               |

## Download ID Code (Use in case of Link Test failure)

Follow these steps to download the transmitter's unique ID Code into the receiver. This will allow the receiver to establish a radio link with that transmitter.

Refer to the **Light Legend** below for diagram details. Refer to **Troubleshooting Chart #4** for Tips and Considerations

**NOTE:** It is necessary to download the ID Code when replacing either the transmitter or the receiver.

**NOTE:** If the transmitter is connected to the receiver with a Tether Cable, completing **only steps 3 and 5** is necessary (it is not necessary to open the R130 case and press the Setup button).

### 1. Opening the R130 Case

The cap is held on by two plastic tabs at opposing sides, which can be unlatched as shown using a screwdriver. Once the cap is free, the R130 can slide open.

Use a small slotted screwdriver to press the Side Tabs inward.

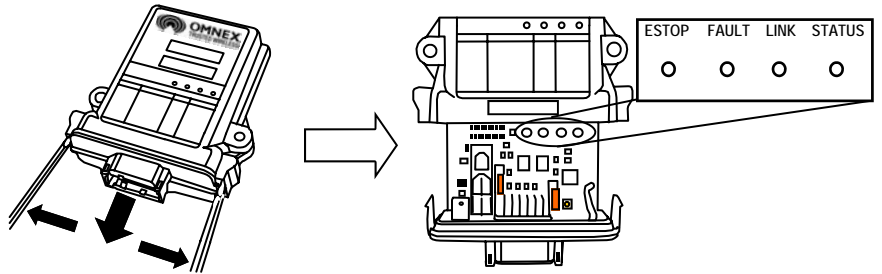

### 2. Prepare T150, Power R130

- A. Press [E-Stop]
- B. Twist clockwise & release [E-Stop]
- C. Supply power to the receiver

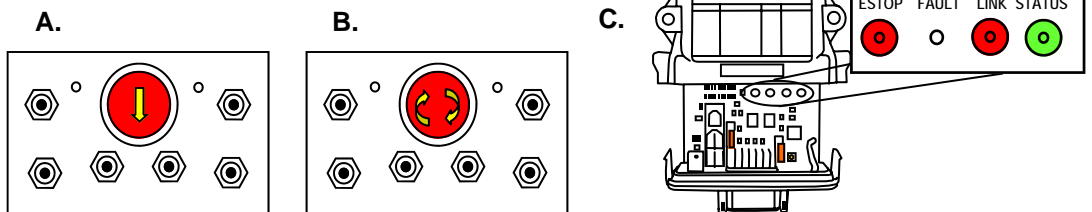

### 3. Power T150 into Configuration Mode

- A. Hold [SW-5] switch UP
- B. Press [E-Stop]
- C. Twist clockwise & release [E-Stop]
- D. Release [SW-5] Switch

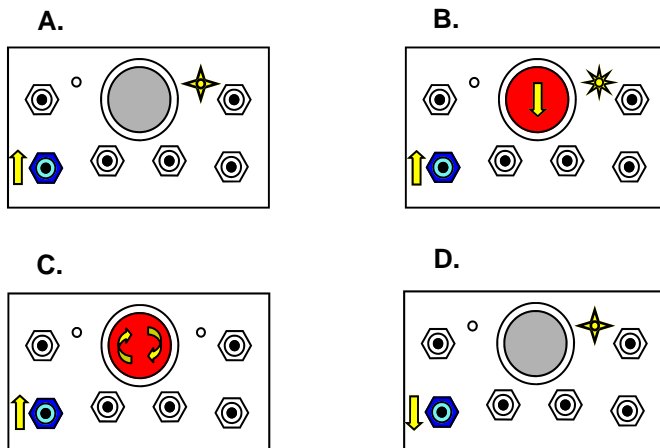

| Light Legend | Solid | Slow Flash | Fast Flash | Red Light | Green Light | Yellow Light | Alternating Red & Green Light |
|--------------|-------|------------|------------|-----------|-------------|--------------|-------------------------------|
|--------------|-------|------------|------------|-----------|-------------|--------------|-------------------------------|

## Download ID Code (Use in case of Link Test failure)

### 4. Put R130 into Setup Mode

A. Press & hold [Setup] button until (Status) light goes from slow flash to fast flash

B. Release [Setup] button. (Status) light goes to solid GREEN, (Link) light turns off

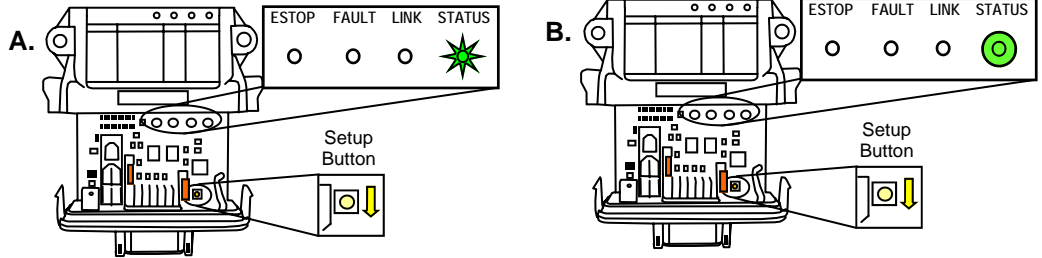

**NOTE:** If left idle in Setup Mode for over 30 seconds, the receiver will time out. The (Link) light and (Status) light will flash RED rapidly. To return to Setup Mode, repeat step 4.

### 5. Download ID Code

**NOTE:** When downloading a new ID to a receiver, a safety feature requires that the transmitter be in close proximity to the receiver. This will prevent a transmitter from accidentally reprogramming a different receiver in the area.

A. Press [SW-5] switch UP

B. (Link) light goes to GREEN. Once complete, (Link) light goes to RED as the transmitter turns off

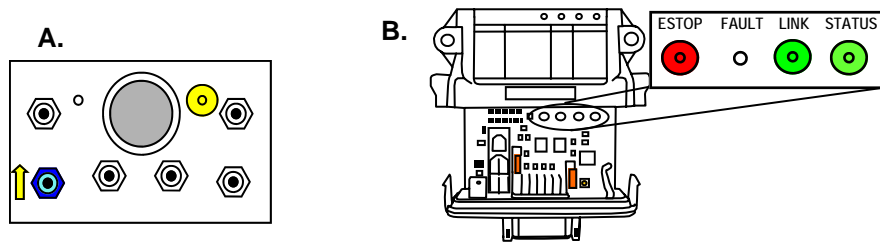

**NOTE:** When replacing the receiver cover, ensure the cover snaps completely into place to create a weather proof seal around the base of the receiver.

### Light Legend

|       |  |            |  |            |  |           |  |             |  |              |  |                               |  |
|-------|--|------------|--|------------|--|-----------|--|-------------|--|--------------|--|-------------------------------|--|
| Solid |  | Slow Flash |  | Fast Flash |  | Red Light |  | Green Light |  | Yellow Light |  | Alternating Red & Green Light |  |
|-------|--|------------|--|------------|--|-----------|--|-------------|--|--------------|--|-------------------------------|--|



# Calibrating Proportional Controls

The transmitter's trigger controls the receiver's proportional output. The trigger is used in conjunction with any of the transmitter's switches. The proportional output can be activated when a switch is held UP or DOWN; it will become active at an increasingly high level as the trigger is pulled. The minimum and maximum levels of the proportional output can be calibrated by following these steps.

Refer to the **Light Legend** below for diagram details.

**NOTE:** Calibration settings can be reset to factory default in steps 4 & 5 by holding the [SW-5] switch UP or DOWN for 5 seconds.

## 1. Prepare T150, Power R130

- Press [E-Stop]
- Twist clockwise & Release [E-Stop]
- Supply power to the receiver

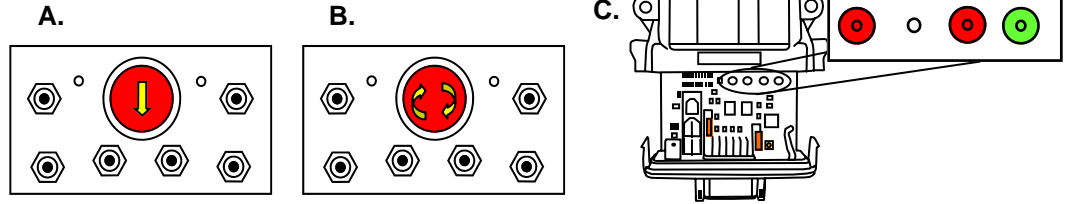

## 2. Power T150 into Configuration Mode

- Hold [SW-5] switch DOWN
- Press [E-Stop]
- Twist clockwise & release [E-Stop]
- Release [SW-5] Switch

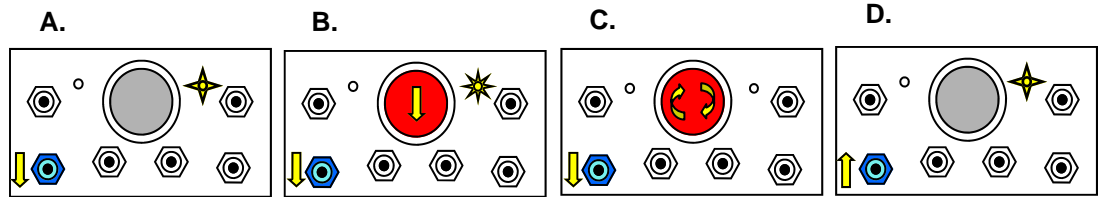

## 3. Setup T150

- Press [SW-5] switch DOWN

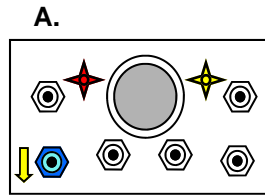

## 4. Set Minimum Level

- Keep Trigger released to set minimum level
- Press [SW-5] switch UP to increase minimum level or DOWN to decrease it

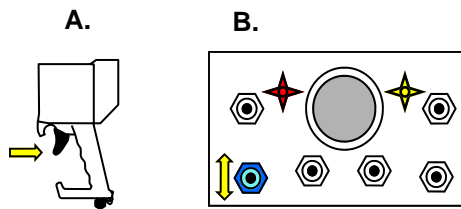

**NOTE:** All switches, except the [SW-5] switch, remain active in Calibration Mode.

A switch can be activated during calibration to help determine the desired levels.

## 5. Set Maximum Level

- Keep Trigger fully engaged to set maximum level
- Press [SW-5] switch UP to increase maximum level or DOWN to decrease it

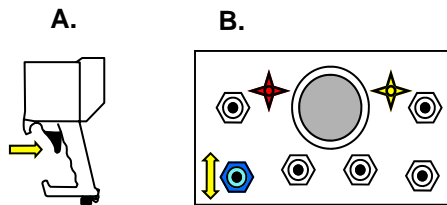

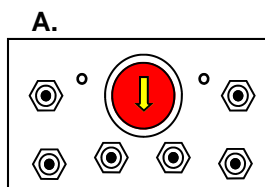

## 6. Power Off

- Press [E-Stop]

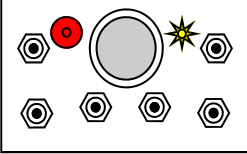
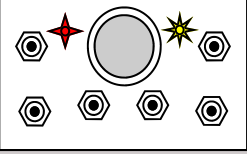
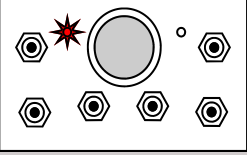
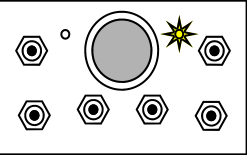
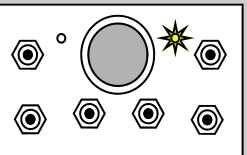
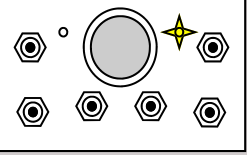
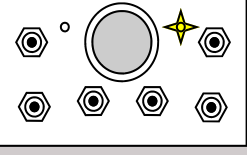
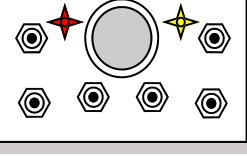

| Light Legend | Solid | Slow Flash | Fast Flash | Red Light | Green Light | Yellow Light | Alternating Red & Green Light |
|--------------|-------|------------|------------|-----------|-------------|--------------|-------------------------------|
|              |       |            |            |           |             |              |                               |

# Diagnosics—T150 Transmitter

|   |  |
|---|--|
|    | Tether connection detected   |
|    | Low battery. Unit will run approximately 10 hours after Battery light starts flashing.   |
|    | Flashing rapidly for 10 seconds indicates a transmitter failure.   |
|    | <b>Normal Operation</b><br>The Active light will flash several times per second, indicating that the transmitter is sending signals to the receiver. The Active light will remain on momentarily whenever a function changes |
|   | <b>On Power Up</b><br>Release the E-Stop button within 10 seconds to power up the transmitter, or the unit will power down.  |
|  | <b>Normal Operation</b><br>The transmitter is in Download Mode.  |
|  | <b>On Power Up</b><br>Press and release the E-Stop button within 10 seconds to power up the transmitter, or the unit will power down.  |
|  | Stuck switch detected. Ensure that all switches are in a centered position. The transmitter will not power up when a function is ON.   |
|  | <b>On Power Down</b><br>Unit is still powered. Check for stuck switches, as the transmitter will not power down when a function is ON. Alternating flash means that the transmitter is in Calibration Mode.                  |

|                     |       |   |            |   |            |   |           |   |             |   |              |   |                               |   |
|---------------------|-------|---|------------|---|------------|---|-----------|---|-------------|---|--------------|---|-------------------------------|---|
| <b>Light Legend</b> | Solid |  | Slow Flash |  | Fast Flash |  | Red Light |  | Green Light |  | Yellow Light |  | Alternating Red & Green Light |  |
|                     |       |   |            |   |            |   |           |   |             |   |              |   |                               |   |

# Diagnostics - R130 Receiver

## Normal Operation

|  |  |
|--|--|
|  | <p>Transmitter is OFF<br/>If the transmitter is off, the receiver is operating properly.</p>   |
|  | <p>Transmitter is ON<br/>When the transmitter is turned on, the Link light (fast flashing) and E-Stop (GREEN) indicates the receiver is operating properly.</p>  |
|  | <p>Transmitter is in Operation<br/>When a function is activated on the transmitter, the Fault light will turn on GREEN. This indicates the receiver is operating properly.</p>   |
|  | <p>Transmitter is OFF<br/>When a latched function is activated then the transmitter is turned off, the Fault light will stay on GREEN. If the system was intentionally designed this way, the receiver is operating properly, if not call for service.</p> |

## Trouble Indicators

**Note:** In some cases, the indicator lights will be different depending on whether the transmitter is on or off. Please note the transmitter status in the "Description" column for each case.

| Indicator Lights | Description   | Solution   |
|------------------|---|--|
|                  | <p>Transmitter is ON<br/>The reason is the transmitter is not communicating with the receiver.</p>  | <p>Refer to <b>Troubleshooting Chart #3</b> for solutions.</p>   |
|                  | <p>Transmitter is ON<br/>A low battery condition has been detected.</p>   | <p>To detect intermittent conditions caused by poor or corroded ground or power circuits, the GREEN light will continue to flash for 30 seconds after the condition has been removed.</p>  |
|                  | <p>Transmitter is ON<br/>An internal fault with the E-Stop has been detected.</p>   | <p>Inspect E-Stop wiring for short circuit. Disconnect E-Stop wire as close to the receiver output as possible. If the Status light changes to:</p> <ul style="list-style-type: none"> <li>• GREEN, a short occurs after disconnection point.</li> <li>• Stays flashing RED, send it in for service .</li> </ul> |
|                  | <p>Transmitter is ON<br/>A short to ground or excessive current draw on an output. It is most likely caused by a wiring fault.</p>  | <p>Ensure transmitter is functioning properly, check status of each output connection: Press each function button and observe Fault Light.</p> <ul style="list-style-type: none"> <li>• If GREEN, everything is OK.</li> <li>• If RED, there is a short in that connection.</li> </ul>                           |
|                  | <p>Transmitter is ON<br/>3 possible causes:</p> <ul style="list-style-type: none"> <li>• E-Stop output connected to an output.</li> <li>• Wiring short to the battery.</li> <li>• 2 output wires connected, indicator comes on when a function is activated.</li> </ul> | <p>Follow the wire and check for connections with other wires, disconnect to see if condition clears. If not, call for service.</p> <p>Refer to <b>Troubleshooting Chart #1</b> for solutions.</p>   |
|                  | <p>Transmitter is OFF<br/>The receiver has detected an internal fault.</p>  | <p>Refer to <b>Troubleshooting Chart #1</b> for solutions.</p>   |
|                  | <p>Transmitter is OFF<br/>Blown fuse detected.</p>  | <p>Refer to <b>Page 7</b> for instructions on how to open the receiver case to access fuse. Check wiring for shorts or bare spots. If fuses continue to blow, call for service.</p>  |

| Light Legend | Solid | Slow Flash | Fast Flash | Red Light | Green Light | Yellow Light | Alternating Red & Green Light |
|--------------|-------|------------|------------|-----------|-------------|--------------|-------------------------------|
|--------------|-------|------------|------------|-----------|-------------|--------------|-------------------------------|

Test the Receiver—R130

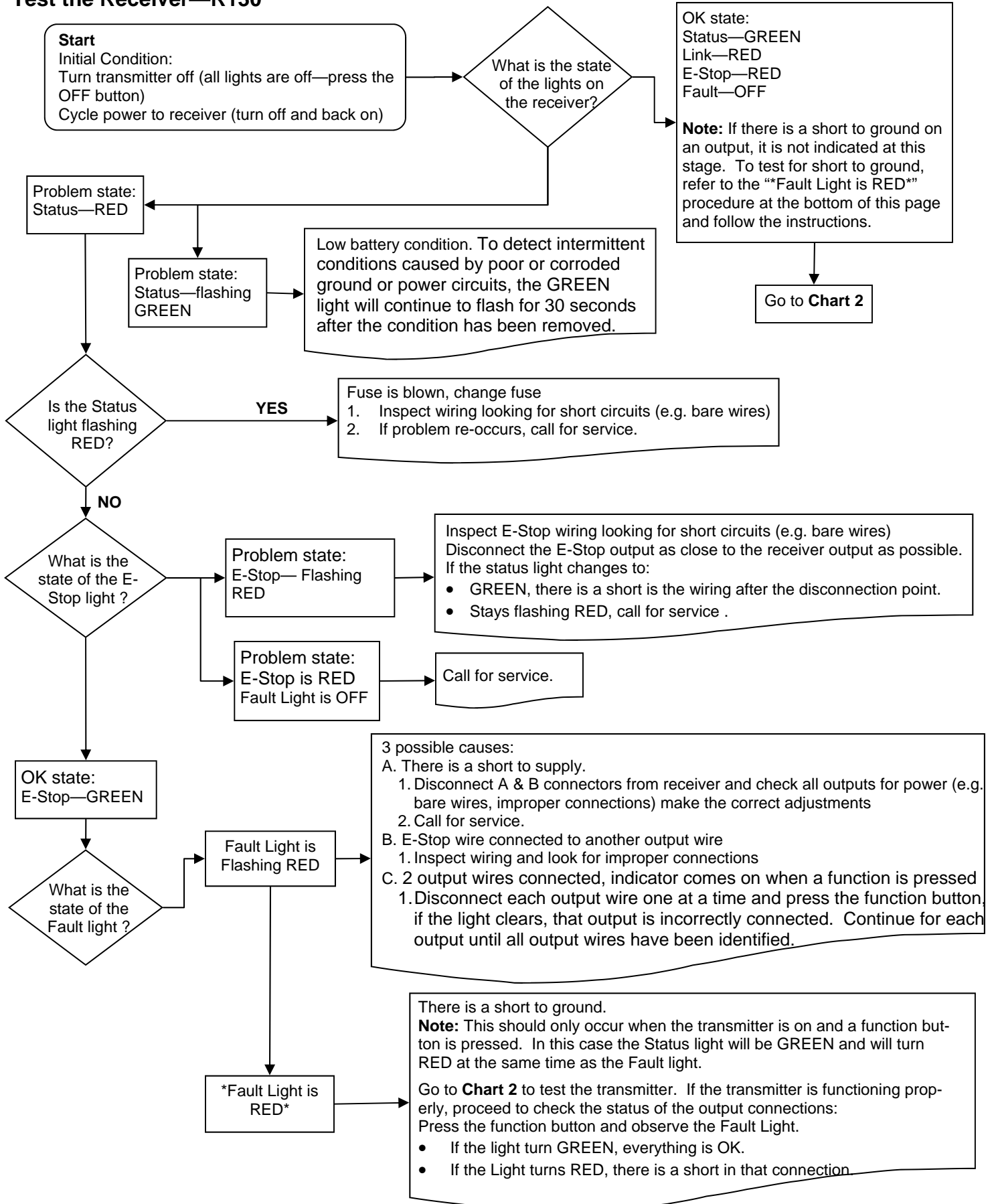

Test the Transmitter—T150

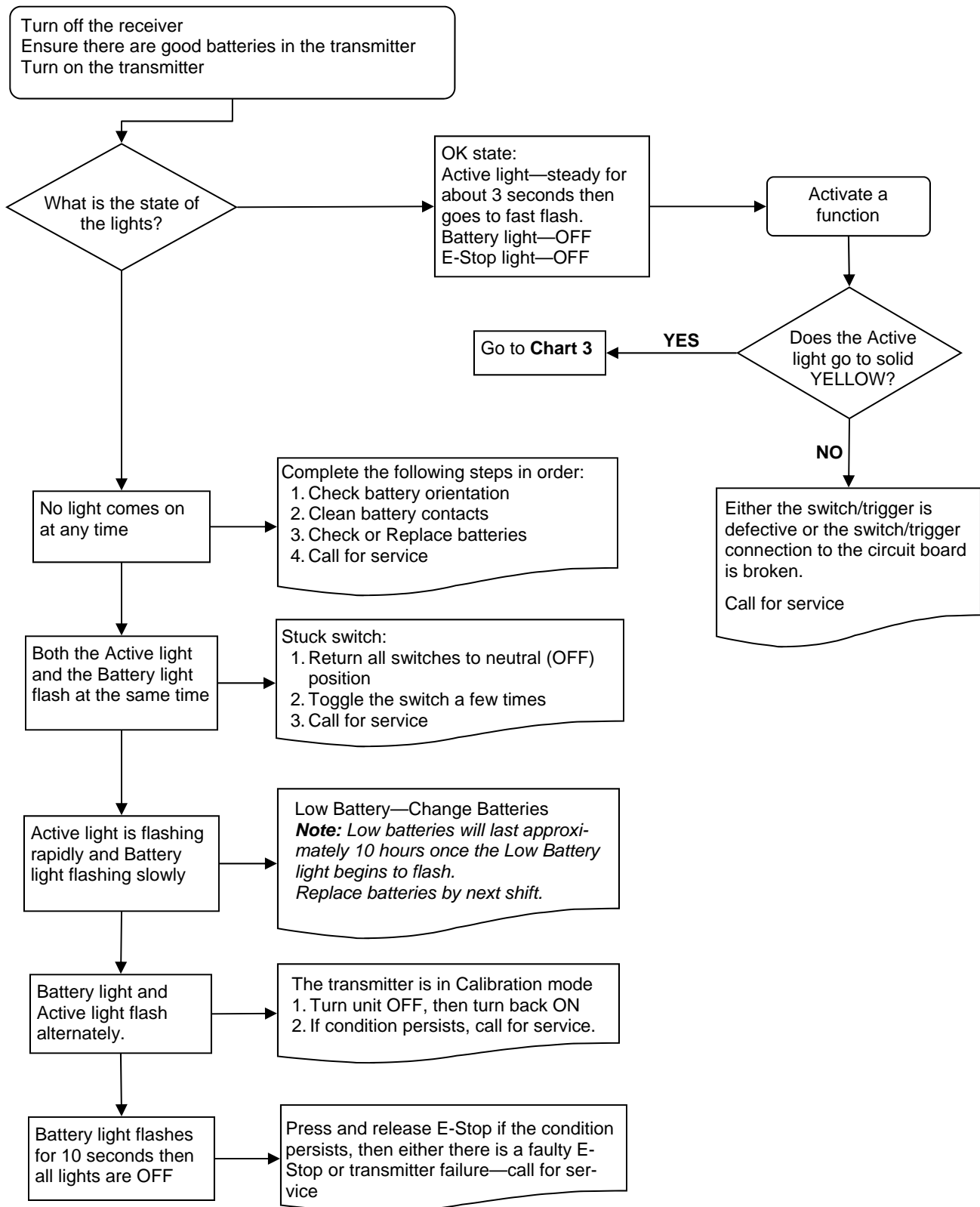

Testing the Transmitter / Receiver Communication

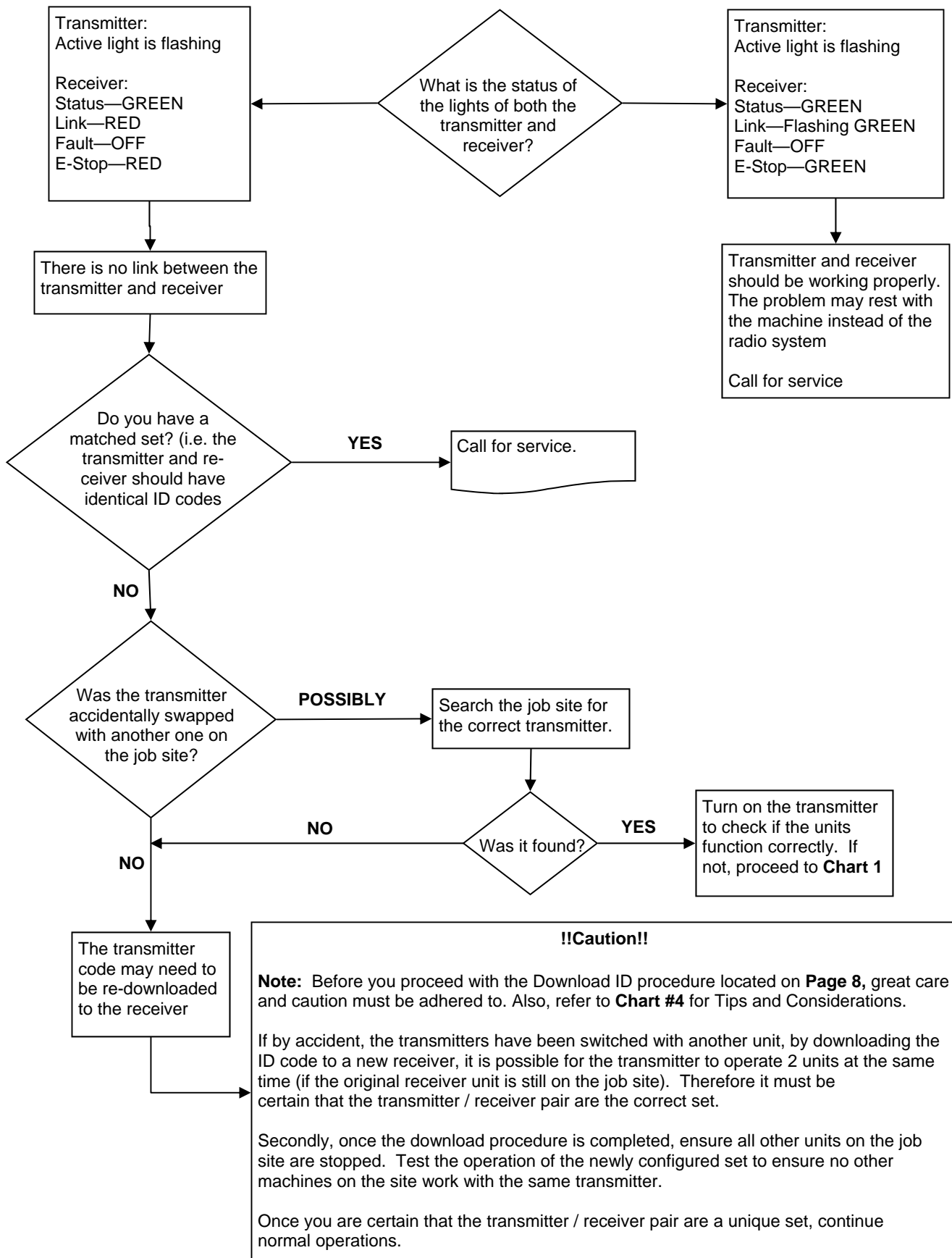

## Considerations when Downloading the ID

### Potential downloading issues

If testing of the receiver and transmitter both show the system as working (Chart 1 & 2), then the transmitter and receiver will both go into Download/Configuration mode.

Possible issues could arise during Step 4, the download phase of reprogramming. In this case there are 2 symptoms to look for:

1. The Link light on the receiver will not turn GREEN when the power switch is toggled on the transmitter to download
2. The receiver will “time out” indicating that it didn’t receive a signal from the transmitter within the 30 seconds from the time the receiver was put into Setup Mode.

If all indications appear normal during the download phase, test the link by turning on the transmitter (note: the transmitter shuts off after transmitting the ID code in Step 4)

1. If the Link light on the receiver doesn’t turn GREEN, the receiver didn’t receive all of the information that was sent from the transmitter.

### Possible Solutions

1. Try the Downloading steps again
2. If this doesn’t correct the problem, send both the transmitter and receiver in for service.

***Note:** you could try to determine whether the fault lies with the transmitter or receiver by completing the downloading procedure with a different transmitter. If this step works, then the fault lies with the original transmitter. If not, the fault may lie with the receiver.*

### **!!Caution!!**

**Note:** Before attempting downloading with another transmitter, understand that reprogramming the receiver with another transmitter, could result in two receivers on the job site responding to the one transmitter. If the original transmitter was sent in for repair,

Disconnect the receiver to continue using the machine without remote capability and without fear of inadvertently operating the machine with the other transmitter.

### Reprogramming Tips:

1. Use a pointy instrument to depress the Setup button on the receiver (i.e. a pen) as the button is relatively small
2. Follow each step as laid out in the procedure
3. Never lay the receiver circuit board down on anything metallic (there are contact points on the back which could contact the metal and damage the receiver)



## Parts & Accessories

| Part                              | Part Number         | Description   |
|-----------------------------------|---------------------|---|
| Batteries                         | B0010               | 4 x AA alkaline   |
| R130 Output Cables                | <b>ACAB-2599-01</b> | Generic Output Cable- see illustration                              |
| T150 Tether Cable (8 m. / 25 ft.) | ACAB-2455-02        | see illustration  |
| Toggle Switch                     | AKIT-1504-04        | Honeywell 1TL1-7  |
| E-Stop Button                     | AKIT-1821-02        | RAFIX16, 25mm, C&K 1.30074.2810300<br>See illustration              |
| Magnet Back                       | AKIT-2498-02        | see illustration  |
| Bipolar Diode Kit                 | AKIT-2492-01        | 36V, Bi-directional, Motorols P6KE36CA                              |
| Fuse                              | F0039               | Bussman ATC-15  |
| Socket Connectors                 | J0418               | Grey, 12-pin, Deutsch DTM06-12SA                                    |
|                                   | J0419               | Black, 12-pin, Deutsch DTM06-12SB                                   |
| Wedge                             | J0420               | 12 pos., Deutsch WM12S  |
| Pin                               | J0417               | Female, Size 20, Deutsch 0462-201-20141                             |
| Sealing Plug                      | J0421               | Size 20, Deutsch 0413-204-2005                                      |
| R130 Connector Kit                | AKIT-2337-01        | Includes Deutsch socket connectors, wedges, pins and sealing plugs. |



R130 Output Cable



Tether Cable



E-Stop



Magnet Back

## Specifications

|                                    | R130 Receiver   | T150 Transmitter   |
|------------------------------------|---|--|
| <b>Size</b>                        | 5.1" x 4.7" x 1.4"<br>(130mm x 119mm x 36mm)            | 7.9" x 4.2" x 4.1"<br>(200mm x 125mm x 105mm)                      |
| <b>Weight</b>                      | 0.65lbs (0.295kg)                                       | 1.8lbs (0.817kg)   |
| <b>Construction</b>                | High impact plastic, weatherproof                       | High impact, low temperature plastic, weatherproof                 |
| <b>Input Power</b>                 | +9V to 30VDC  | 4AA alkaline batteries   |
| <b>Battery Life</b>                | N/A   | >120 hours (continuous use)  |
| <b>Operating Temperature Range</b> | -40F to 158F (-40C to 70C)                              | -40F to 158F (-40C to 70C)   |
| <b>Outputs</b>                     | 3A (max) each (sourcing),<br>10A (max) each (combined)  | N/A  |
| <b>Antenna</b>                     | Internal  | Internal   |
| <b>Approvals</b>                   | <b>USA-</b> FCC part 15.247<br><b>Australia-</b> C-Tick | <b>Canada-</b> ISC RSS 210 Issue 6, Sept.<br><b>Europe-</b> EN 440 |

### FCC Rules and Compliance

This device complies with Part 15 of the FCC Rules. Operation is subject to the following two conditions: (1) This device may not cause harmful interference, and (2) this device must accept any interference received, including interference that may cause undesired operation.

FCC Part 15.247  
ISC RSS 210 Issue 6, Sept. 2005

### Warranty

OMNEX Control Systems ULC warrants to the original purchaser that the OMNEX products are free from defects in materials and workmanship under normal use and service for a period of ONE YEAR, parts (EXCLUDING: SWITCHES, CRYSTALS, OR PARTS SUBJECT TO UNAUTHORIZED REPAIR OR MODIFICATION) and labor from the date of delivery as evidenced by a copy of the receipt. OMNEX's entire liability and your exclusive remedy shall be, at OMNEX's option, either the (a) repair or (b) replacement of the OMNEX product which is returned within the warranty period to OMNEX freight collect by the OMNEX APPROVED carrier with a copy of the purchase receipt and with the return authorization of OMNEX. If failure has resulted from accident, abuse or misapplication, OMNEX shall have no responsibility to repair or replace the product under warranty. In no event shall OMNEX be responsible for incidental or consequential damage caused by defects in its products, whether such damage occurs or is discovered before or after replacement or repair and whether or not such damage is caused by the negligence of OMNEX Control Systems ULC.

### OMNEX Control Systems ULC

74-1833 Coast Meridian Road  
Port Coquitlam, BC, Canada  
V3C 6G5

Tel: 604-944-9247  
Fax: 604-944-9267

**Toll Free: 1-800-663-8806**

[www.omnexcontrols.com](http://www.omnexcontrols.com)