



IN1115 Edition G3 Installation Instructions For

HARMONY
H13, H23, H33, H43
STANFORD
S13, S23, S33, S43
SP23, SP33, SP43
NESTOR MARTIN
R23, R33
RH33, FH33

Wood and Multifuel Stoves
With Plexus Control and ZR Technology

This manual must be used in conjunction with document IN1173.
The Wood and Multifuel Chimney and Installation Guide.

Since April 2002 only Registered Competent Engineers may install solid fuel fired appliances without involving the Local Authority Building Control Department. For more details contact HETAS.

Euroheat would suggest only Registered Competent Engineers install Euroheat appliances.

If the installer is not a registered Competent Engineer we would advise that property owners insurance company is contacted to confirm their insurance is not effected.

Part No.
Model Name
Serial Number

This Manual Must Always Be Available To The Stove Operator

IMPORTANT

- The installation of this appliance must comply with all local regulations, including those referring to national and European Standards before it can be operated. The stove is not suitable for a shared flue. However, for England and Wales, only, the coming into force on 1st April 2002 of SI 2002 No 440 exempts the householder from this legal requirement for the installation of solid fuel fired appliance whose rated heat output is 50kW or less in a building having no more than 3 storeys (excluding any basement) if a Competent Engineer is employed who is registered under the Registration Scheme for Companies and Engineers involved in the Installation and Maintenance of Domestic Solid Fuel Fired Equipment operated by HETAS Ltd. These registered Competent Engineers may also carry out associated building work necessary to ensure that the installed appliance complies with Building Regulations without involving the Local Authority Building Control Department.
- Improper adjustment, alteration, maintenance or the fitting of replacement parts not recommended by the manufacturer can cause injury or property damage. Do not operate the stove with faulty seals or damaged glass.
- Due to the high operating temperatures of this appliance it should be located away from pedestrian traffic and away from furniture and draperies. Do not store paper or wood near the appliance. Any mats and rugs put in front of the stove should be fire proof and secured to prevent the possibility of tripping.
- Advise all persons as to the stove's high surface temperatures. If it is possible for children or infirm adults to come into contact with the stove, fit a suitable fire guard.
- It is imperative that all air passageways into, out of, and within the appliance are kept clean. All permanent ventilation into the room provided for the stove must remain clear and unobstructed at all times. Consideration must be given to the need for extra ventilation if another heating source needing air is to be operated simultaneously. If an extraction fan is proposed to be fitted to a connecting area of the house, after the stove has been installed, professional advice should be sought from a qualified engineer.
- The user should be advised that the appliance should be inspected regularly and the chimney cleaned at least annually. More frequent cleaning may be required and the advice of a qualified chimney sweep should be sought.
- Our range of stoves is capable of operating with outstanding efficiency if the flue system is correct. Because so little heat is wasted to the flue it is possible that moisture within the products of combustion will condense if the heat losses within the flue way are too great and allow the flue gases to cool. For this reason we recommend that the stove is fitted with a suitable flue liner, the same diameter as the flue spigot, to prevent the possibility of acidic damage to the fabric of the chimney and damage to the stove which will reduce the longevity of the stove.
- When correctly installed, the stove is designed to produce heat, safely. It cannot do so if the installation is less than absolutely stable, constructed of materials suitable for such an installation and consideration has not been given to the possibility of people with less than ideal common sense operating it.
- Have the existing chimney swept by a chimney sweep. Although you will be lining the chimney, any deposits left in the chimney will cause problems and may become a fire hazard.
- Your attention is drawn to the precautions and responsibilities under the Health and Safety at Work Acts, and whatever new legislation being introduced during the life of this document.

The Model Range Explained

Nestor Martin and Euroheat insist on progressive development to produce products which are market leading. Our aims are to produce stoves with the latest innovations, user friendly operation and highly efficient for lower cost operation.

This manual offers installation information for the range of HARMONY H13, H23, H33, H43. STANFORD S13, S23, S33, S43 SP23, SP33, SP43. NESTOR MARTIN R23, R33 RH33, FH33.

In some cases you find references in this document to the model size rather than the models exterior design. There are four sizes of appliances, 13, 23, 33, 43. The 13 is the smallest and the 43 the largest. Although the exterior clothes change between model ranges, for example the Harmony 23 and the Stanford 23, the internal workings are the same. Exceptions: The SP models are fitted with a top hot plate for warming operations.

Model Identification

You will see on the front page of this document a label which confirms which model you have. This label also advises you of the stoves unique serial number. This information is also attached to your stove for reference.

Important

Please ensure the warranty registration form is completed if you are the installer and confirm with the user that it is their responsibility to return it to Euroheat. In this way the model and its history will be recorded for reference in the future.

For the latest versions of manuals, technical information, accessories and spare parts visit the euroheat web site.



Natural Energy Company

Stoves supplied through Euroheat authorized retailers. For England, Wales, Scotland and Northern Ireland

Euroheat Distributors (H.B.S). Ltd.

Unit 2,
Court Farm Business Park,
Bishops Frome,
Worcestershire. WR6 5AY.

www.euroheat.co.uk

info@euroheat.co.uk

Whilst Euroheat are always happy to assist, please ensure you have read this manual and the chimney and installation guide IN1173.

First contact your supplying retailer for assistance. If you find this not successful contact the Euroheat Technical support team. Technical support telephone Number 01885 491117. E-mail tech@euroheat.co.uk.

Before telephoning ensure you have the stoves serial number to hand and that you are a Registered Competent Engineer. If you are not a registered engineer seek one for assistance. A list of engineers can be obtained from HETAS.

Euroheat unfortunately are able to offer support for appliances which were not supplied by Euroheat.



Stoves supplied through Eireheat authorized retailers.

For Eire

Sean Murphy Heating Ltd
Kinvara
Co Galway
Eire

www.eireheat.com

sales@eireheat.com

(091)637701 Fax: (091)637797
International +353 91637701

For support for appliances supplied through Eireheat in Ireland please contact using the details listed above.

**NESTOR
MARTIN**

Thermic Distribution Europe Sa
11 Rue De Lion
B-5660
Frasnes Les Couvin, Belgium.

www.nestormartin.com

Technical Details Intermittent Operation

Intermittent operation is when the appliance is used for short firing periods for example 45 minutes to 2 hours. This is a common operation in warmer weather such as cold spring evenings. The information provided below where indicated as HETAS approved is from the current CE standards EN 13240:2001 and EN 13240 A2:2004. The test fuel for wood burning, Beech, for Coal burning Anthracite.

Model Name	Model Number	Heat Output Nominal Wood	Heat Output Nominal Coal*	Weight KG	Flue Draught Nominal	Flue Gas Mass Flow g/s	Flue Gas Temperature Down Stream of Flue Spigot deg C	Efficiency with Top Flue Connection
Harmony 13 Wood	H13*	4.6kW		96	12pa	4.9	293	77.1% Net 70.2% Gross
Harmony 13 Coal	H13*		3.6kW	96	12pa	3.8	210	82.8% Net 75.4% Gross
Harmony 23	H23*	5.9kW	6.1kW	124	12pa	7.7	326	See smoke control exempted table
Harmony 33	H33	7.9kW	8.4kW	143	12pa	6.5	357	
Harmony 43	H43*	10.5	11.3kW	186	12pa	6.5	357	
Stanford 13 Wood	S13*	4.6kW		96	12pa	4.9	293	77.1% Net 70.2% Gross
Stanford 13 Coal	S13*		3.6kW	96	12pa	3.8	210	82.8% Net 75.4% Gross
Stanford 23	S23*	5.9kW	6.1kW	124	12pa	7.7	326	See smoke control exempted table
Stanford SP23 HP	SP23 HP*	5.9kW	6.1kW	132	12pa	7.7	326	
Stanford 33	S33	7.9Kw	6.1kW	146	12pa	6.5	357	
Stanford SP33 HP	SP33 HP	7.9kW	8.4kW	153	12pa	6.5	357	
Stanford 43	S43*	10.5Kw	11.3kW	186	12pa	6.5	357	
Stanford SP43 HP	SP43 HP*	10.5Kw	11.3kW	196	12pa	6.5	357	
Nestor Martin R23	R23*	5.9kW	6.1kW	103	12pa	7.7	326	
Nestor Martin R33	R33	7.9kW	8.4kW	125	12pa	6.5	357	
Nestor Martin RH33	RH33*	8.4kW	7.2kW	143	12pa	6.5	357	
Nestor Martin FH33	FH33*	8.4kW	7.2kW	141	12pa	6.5	357	
* HETAS Approved								

Models indicated above as HETAS approved to a certain flue position are indicated by **

Technical Details Continuous Operation

Continuous operation is when the appliance is used for long firing periods for example several hours and for overnight operation. This is a common operation in cold weather as experienced in deep winter. The information provided below is from the current CE standards EN 13240:2001 and EN 13240 A2:2004. The test fuel for wood burning, Beech, for Coal burning Anthracite.

Model Name	Model Number	Heat Output Nominal Wood	Heat Output Nominal Coal*	Weight KG	Flue Draught Nominal	Flue Gas Mass Flow g/s	Flue Gas Temperature Down Stream of Flue Spigot deg C	Efficiency with Top Flue Connection
Harmony 13 Wood*	H13	5.4kW		96	12pa	4.9	293	83.4% Net 75.9% Gross
Harmony 13 Coal*	H13		3.5kW	96	12pa	3.8	210	78.3% Net 71.2% Gross
Stanford 13 Wood*	S13	5.4kW		96	12pa	4.9	293	83.4% Net 75.9% Gross
Stanford 13 Coal*	S13		3.5kW	96	12pa	3.8	210	78.3% Net 71.2% Gross

* HETAS Approved

Smoke Control Exempted



Models listed as smoke control exempted have passed the very strict U.K. requirements and can operate in smoke control zones burning dry seasoned wood.

Model	Flue Size	Air Requirement Equivalent Area as Approved Document J	UK Smoke Control Exemption Burning Wood	Efficiency Net % Rear flue	Efficiency Net % Top flue	Efficiency Gross % Rear flue	Efficiency Gross % Top flue
Harmony 13	5" (125mm)	Nil*	Approved	See intermittent or continuous operation			
Harmony 23	6" (153mm)	1100mm ²	Approved	73**		65.7**	
Harmony 33	6" (153mm)	2750mm ²	Approved	77.6			
Harmony 43	7" (180mm)	4125mm ²		80**		72.8**	
Stanford 13	5" (125mm)	Nil*	Approved	See intermittent or continuous operation			
Stanford 23	6" (153mm)	1100mm ²	Approved	73**		65.7**	
Stanford SP23 HP	6" (153mm)	1100mm ²	Approved	73**		65.7**	
Stanford 33	6" (153mm)	2750mm ²	Approved	77.6			
Stanford SP33 HP	6" (153mm)	2750mm ²	Approved	77.6			
Stanford 43	7" (180mm)	4125mm ²		80**		72.8**	
Stanford SP43 HP	7" (180mm)	4125mm ²		80**		72.8**	
Nestor Martin R23	6" (153mm)	1100mm ²	Approved	73**		65.7**	
Nestor Martin R33	6" (153mm)	2750mm ²	Approved	77.6			
Nestor Martin RH33	7" (178mm)	2750mm ²		77.6**		69.7**	
Nestor Martin FH33	7" (178mm)	2750mm ²		77.6**		69.7**	

* Air requirement equivalent area. Building regulations Document J, advises that an air supply should be installed for appliances with a heating output over 5kW. Document J indicates that there should be sufficient advantageous air for heating outputs below this amount. With modern properties this may not always be the case and/or more free air may be required. Continuous or intermittent operation will result in different heating outputs due to the nature of the fuel and the appliance. If in doubt increase the suggested area listed or contact your HETAS approved engineer for assistance.

Useful Organisations UK

Solid Fuel Association

0845 601 4406

www.solidfuel.co.uk

The National Association of Chimney Sweeps

01785 811732

www.chimneyworks.co.uk

HETAS Ltd.

0845 634 5626

www.hetas.co.uk

Stoves Construction

The plexus control is the centre of the air inlet system. The fuel select lever, controls the direction of air flow, either air wash or under grate. The burning rate control governs the amount of air entering the fire.

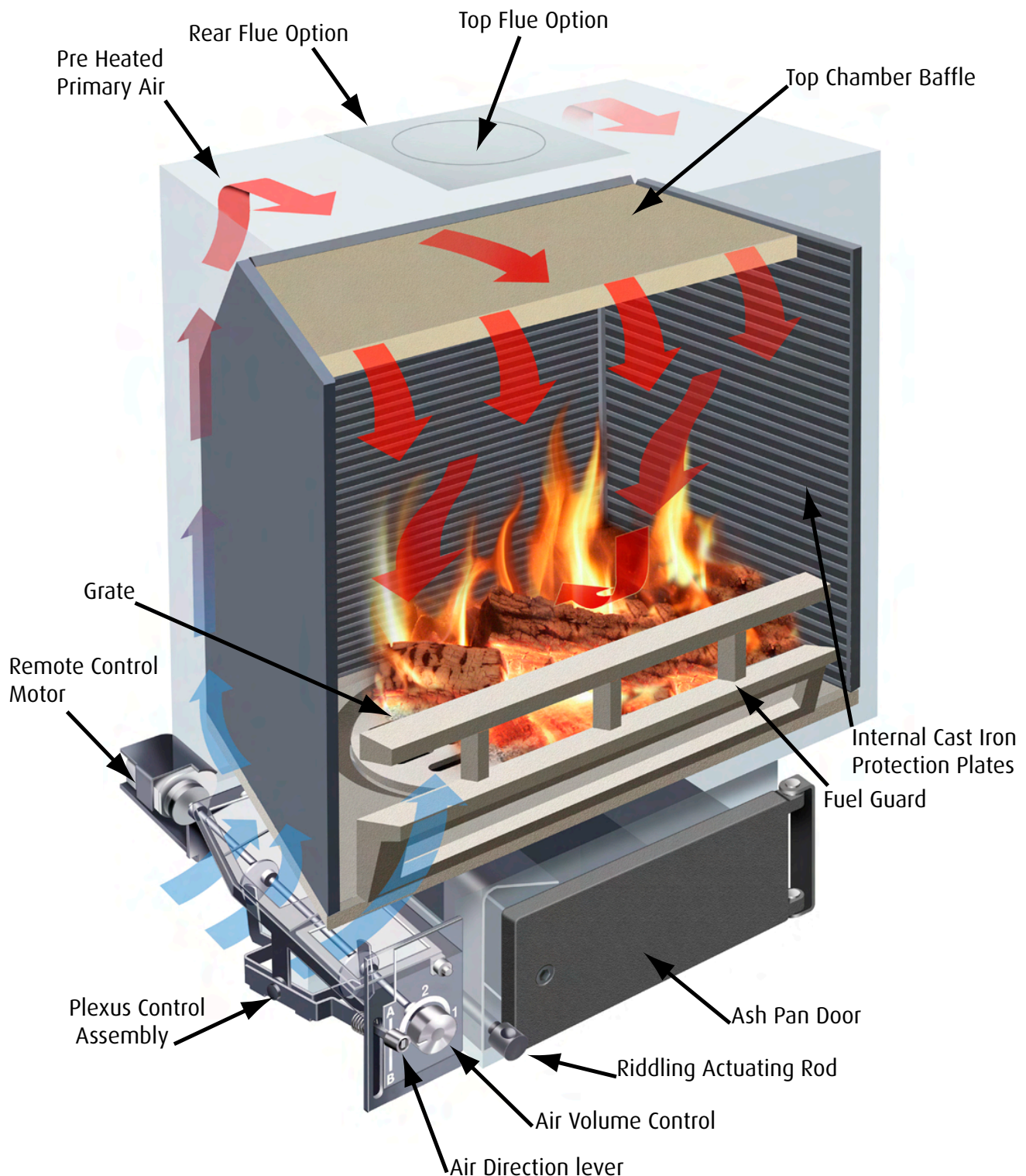

Flue Outlet Configuration

Top Flue Connection

When using top flue outlet the flue spigot with certain models is fitted with a flue spigot protector. This protection tube prevents damage to the flue outlet and slows down the movement of flue gases to the flue system. See table below for model information.

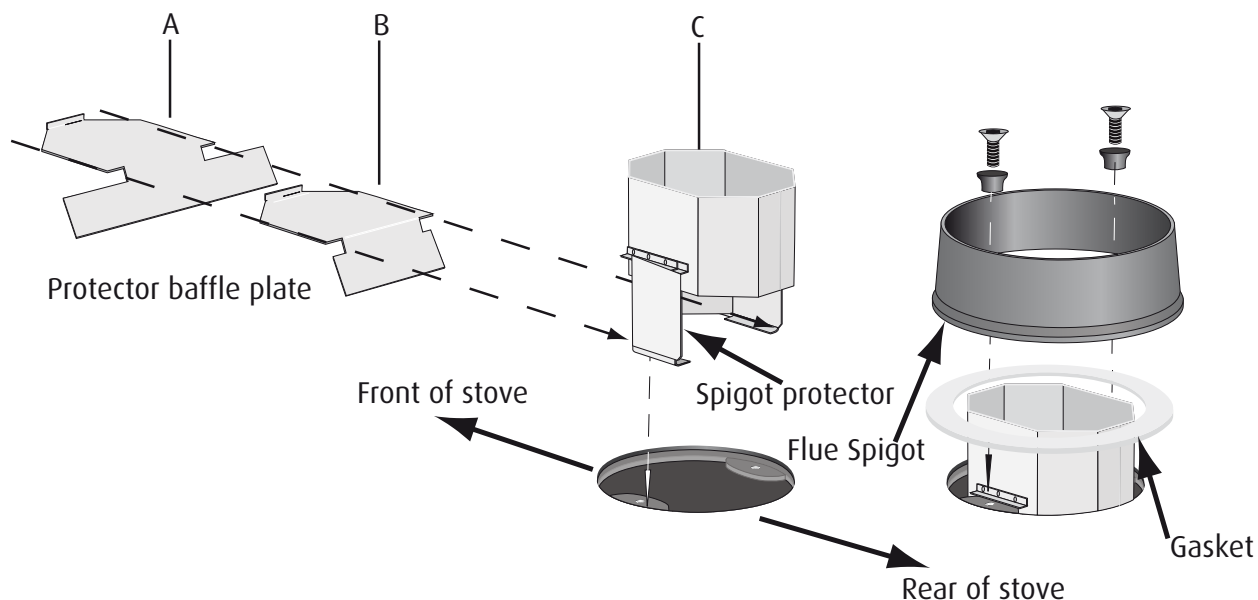

Correct configuration of spigot protector and protector baffle plate.		
Model	Flue Protector (C)	Protector Baffle Plate (A) or (B)
Harmony 13	Yes	B
Harmony 23	Yes	B
Harmony 33	Yes	A or B
Harmony 43	Yes (only enamel Models)	No
Stanford 13	Yes	B
Stanford 23	Yes	B
Stanford SP23	No	No
Stanford 33	Yes	A or B
Stanford SP33	No	No
Stanford 43	Yes (only enamel models)	No
Stanford SP43	No	No
Nestor Martin R23	Yes	No
Nestor martin R33	Yes	A or B
Nestor Martin RH33	No	NO
Nestor Martin FH33	No	NO

Changing to Rear Flue Connection

1. Remove the top chamber baffle plate (see page 5). **Caution** the top chamber baffle is fragile. See operating instructions for information on removal.
2. Then remove protector baffle plate if fitted (see page 6).
3. Replace the top chamber baffle.
4. Remove flue spigot and spigot protection from top of stove.
5. Some models will require the rear heat shield rear flue access plate to be removed. With a hack saw blade or similar remove the section from the rear heat shield which covers the rear flue outlet.
6. Remove flue blanking plate from rear of stove.
7. Fit the blanking plate to top of stove with the blanking plate protector. This protection plate is supplied with cast iron models only (H&S 13,23,33,43).
8. Fit flue spigot to rear of stove (do not fit spigot protector).

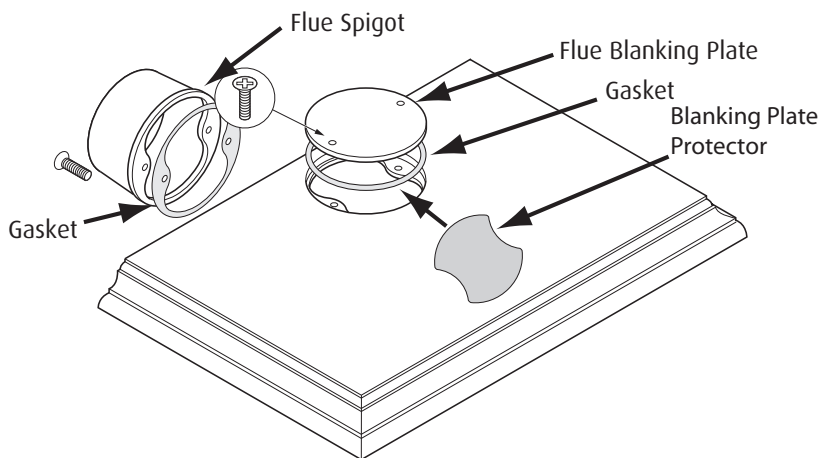

Top flue blanking plate location.

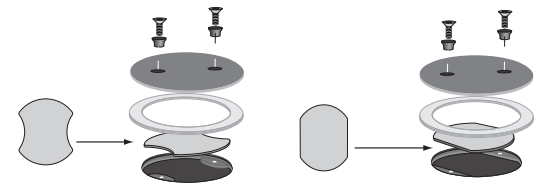

9. The Nestor Martin R23, R33, RH33, FH33 have an additional top closing plate for the top cover. This is retained in place by a square steel plate which is supplied with the stove. This plate slides into fixings under the top removable plate. Once this is fitted the round steel finishing plate can be put into place.

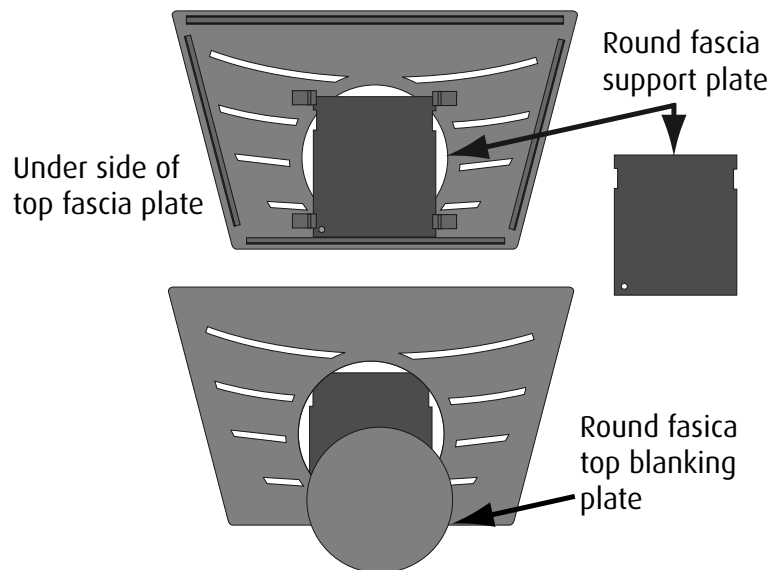

Changing to Top Flue Connection

The procedure is as fitting rear flue but follow the information in reverse and fit the flue spigot protector and protector baffle plate. (See page 6)

Fireplace Design

Do not be tempted to fit the stove into an unsuitable fireplace. Beyond the requirements of Building Regulations and access to facilitate servicing the stove, providing a setting which will compliment a stove is not a luxury, it is the practicality of making the most of an investment. A good builder or fireplace specialist will be able to transform even the most utilitarian of fireplaces. Whether altering its proportions to those of the "Golden Mean" ideal, see below, or exposing a wooden or stone lintel or simply removing superfluous detailing for a comparatively small cost, and the result will be a pleasure for many years.

"Golden Mean"

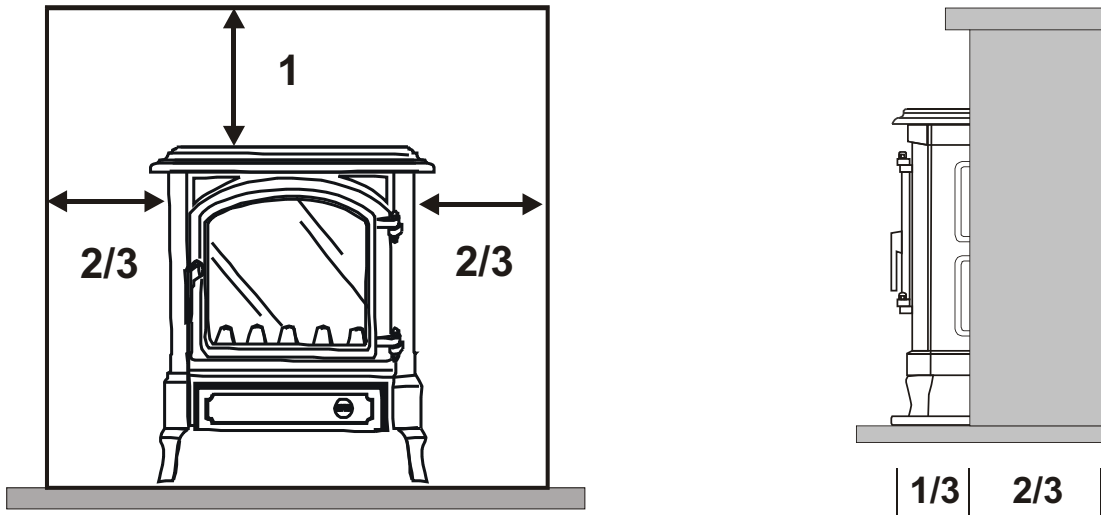

1. The stove must always stand perfectly level. Adjustment screws and/or triangular plastic levelling spacers may be provided with the stove. The provision of a suitable level hearth within the recess is an important consideration when planning a fireplace.
2. Sufficient space should be allowed for service work.
3. At least the minimum clearance from inflammable materials and conforming to the current Building Regulations.
4. Sufficient space around the stove so that the controls may be operated without the risk of injury to the operator.
5. Mounting brackets should be installed to facilitate the secure fitting of a fire guard, if one is to be fitted to protect the young, elderly or infirm.
6. Curtains and soft furnishings should be a minimum of 1m from the stoves body or the surface temperature of these furnishings must not exceed 65°C.
7. The mounting of expensive paintings, mirrors and plasma screen televisions above a fireplace is not recommended.

Hearths

The stove should stand wholly above a hearth constructed of suitably robust materials and should be able to accommodate the weight of the appliance and its unsupported flue components. The materials should conform to local Building Regulations and British Standards.

If the stove is not to stand in a purpose built fireplace recess (this excludes prefabricated constructions) a hearth made of non-combustible board, steel material, tiles or glass of at least 12mm thick may be used as long as the floor can accommodate the weight of the appliance and its unsupported flue components.

All our multifuel stoves conform to standards where the hearth temperature does not exceed 100°C. This means a hearth of only 12mm of non combustible material can be used. This information only applies to our range of appliances. **Caution** do not fit a 12mm hearth to other manufactures products unless documentation is provided to prove hearth temperatures.

Minimum Installation Clearances

From Combustible Materials.

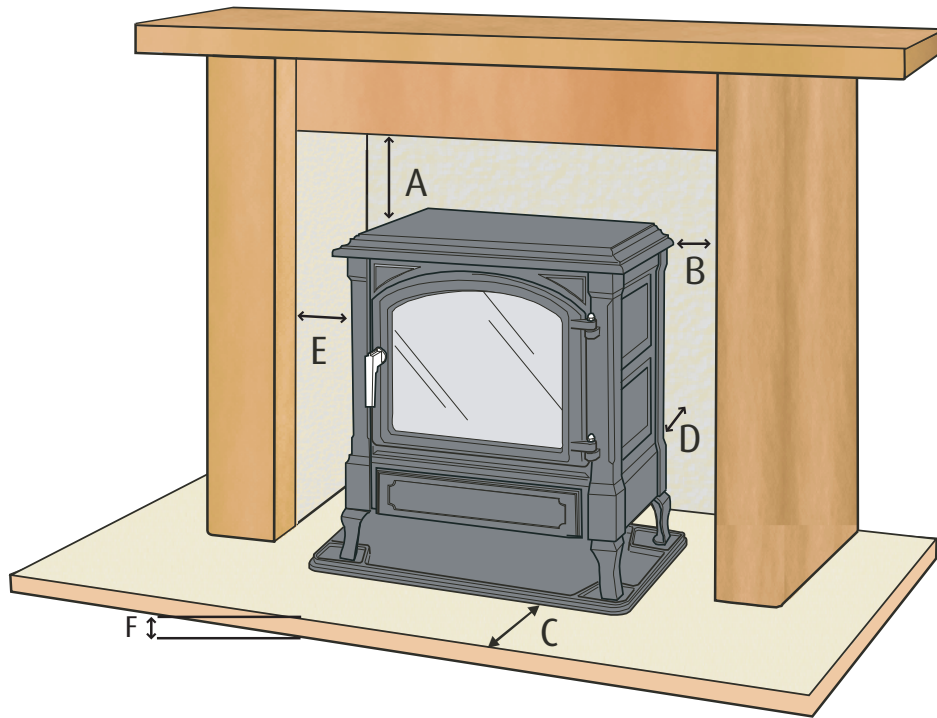

Minimum clearances from combustible materials						
Model	A	B	C	D	E	F*
Harmony 13 Wood	300mm	150mm	300mm	200mm	150mm	12mm
Harmony 13 Multifuel	300mm	150mm	300mm	200mm	150mm	12mm
Harmony 23 Wood	300mm	250mm	300mm	300mm	250mm	12mm
Harmony 33 Wood	300mm	250mm	300mm	300mm	250mm	12mm
Harmony 43 Wood	300mm	250mm	300mm	300mm	250mm	12mm
Stanford 13 Wood	300mm	150mm	300mm	300mm	250mm	12mm
Stanford 13 Multifuel	300mm	150mm	300mm	300mm	250mm	12mm
Stanford 23 Wood	300mm	250mm	300mm	300mm	250mm	12mm
Stanford SP23 Wood	300mm	250mm	300mm	300mm	250mm	12mm
Stanford 33 Wood	300mm	250mm	300mm	300mm	250mm	12mm
Stanford SP33 Wood	300mm	250mm	300mm	300mm	250mm	12mm
Stanford 43 Wood	300mm	250mm	300mm	300mm	250mm	12mm
Stanford SP43 Wood	300mm	250mm	300mm	300mm	250mm	12mm
Nestor Martin R23 Wood	300mm	250mm	300mm	300mm	250mm	12mm
Nestor Martin R33 Wood	300mm	250mm	300mm	300mm	250mm	12mm
Nestor Martin RH33 Wood	300mm	250mm	300mm	300mm	250mm	12mm
Nestor Martin FH33	300mm	250mm	300mm	300mm	250mm	12mm

* When installed as a free standing appliance or in a prefabricated fireplace. All other applications must conform to current constructional fireplace requirements per Building regulations with a constructional hearth. In all installations surrounding flammable materials must not exceed 65°C.

Curtains and furnishings should be a minimum of 1m from the stove or the surface temperature must not exceed 65°C.

Minimum Installation Clearances

From Non-combustible Materials.

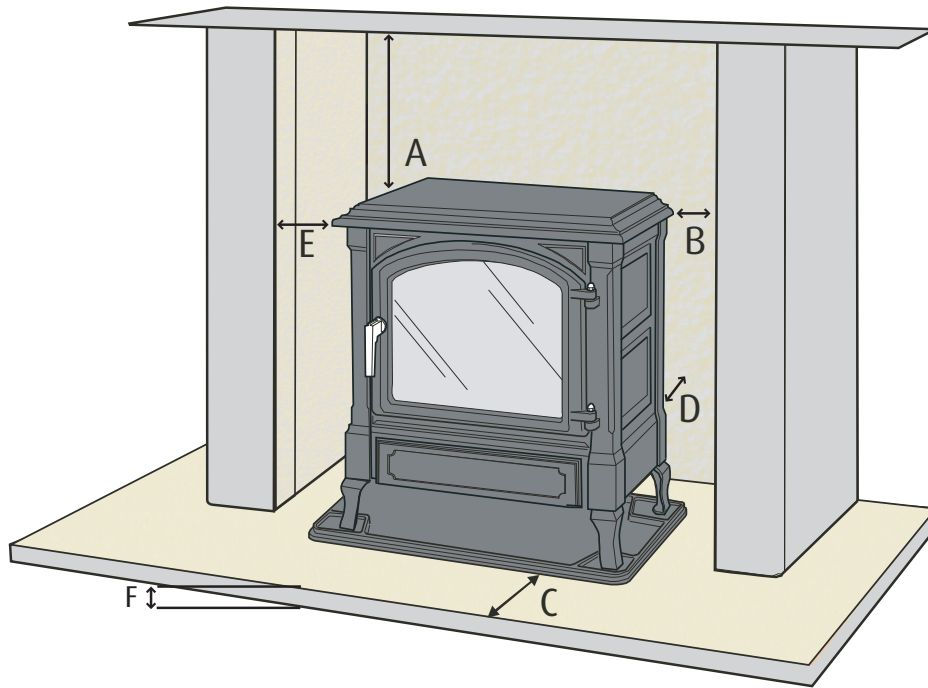

From Non-combustible materials					
A	B	C	D	E*	F**
100mm	75mm	300mm	50mm	75mm	12mm

* If a remote control is to be used with the appliance, the distance E requires to be increased to at least 100mm to allow access to the remote control receiver. If this space is not available a remote mounted receiver can be installed.

** When installed as a free standing appliance or in a prefabricated fireplace. All other applications must conform to current constructional fireplace requirements as per Building regulations.

General advice

Not all fireplace apertures are square or rectangular box's. In cases of where apertures taper or there is an arch top for example a careful assessment should be made to confirm operational clearances can be achieved.

Rules of thumb.

If the clearances at the sides are small but the clearances at the top are large this will still allow access to remove remote control motor if fitted.

Heat likes to rise, allow as much space as possible above the appliance for heat to escape into the room. If there is only a small aperture above the stove bring the stove out into the room by at least 2/3 to assist with the heat distribution.

Always consider that the stove is a heating appliance and would distribute its heat best when free standing. So allow as much space around the stove as possible even if it requires removal of fireplace surround material to create an ideal opening. (Expert building advice may be required).

The Flue

It is possible to remove the top chamber baffle to access the flue for cleaning. However we would advise that if at all possible an external cleaning access is provided. If the chimney has been lined with the same size flue as the flue pipe it will be possible to sweep from the flue access point. If the flue is of a larger size than the flue pipe it may not be possible to use a sweeping brush of adequate size. In which case another cleaning access will be required. For detailed information see IN1173 The Wood and Mutliful Chimney and Installation Guide.

Minimum Air Setting

The air shutter governing the air to the air wash system is divided into two flaps. The larger flap is controlled directly by the operation of the cam and air volume control. The smaller flap is operated by an adjustable screw fitted to the larger flap. This allows the smaller flap to follow the movements of the larger flap as it opens and closes but by adjusting the screw it is possible to set a minimum closing position of the smaller flap to provide a constant air bleed.

The screw is adjusted at the factory to give the maximum air bleed setting. This setting under normal chimney and fuel conditions should be correct.

This facility of having an adjustable minimum air setting provides a positive repeatable air setting that will give the lowest burning rate at which the stove will continue burning when the firing rate control is turned to its minimum position. It will also give a small feed to the air wash when the stove is burning coal, not enough to risk damage to the grate, but enough to help keep the glass clean. It is also an important safety feature. If the stove has been burning with a constant air supply it has been generating and burning the volatile gases from the fuel. If the air supply is abruptly and completely removed the fire will extinguish but the release of gases will continue for some time. These gases will be above their ignition temperature and be potentially explosive if they come into contact with air. The constant air bleed that the small flap allows will keep some of these gases burning and prevent sudden ignition whilst the generation of gases reduces.

Adjustment

If it is found that the fire burns for only short periods while set to the "0" position it will be most likely that the flue draught is high. Commonly found in tall or excessive sized chimneys.

To extend the burning cycle the minimum flap can be adjusted to allow less air to enter at low settings. Adjust the flap to give your required settings.

Important

Do not fully close the flap.

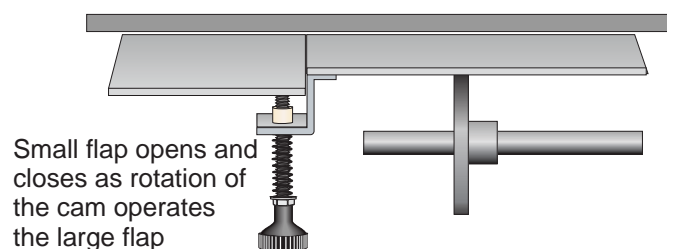
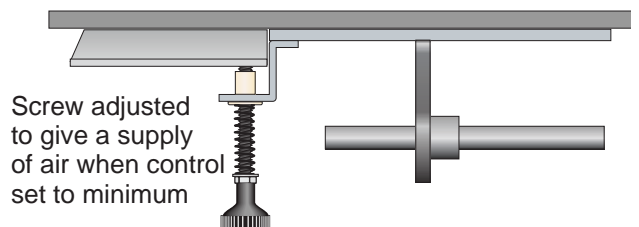
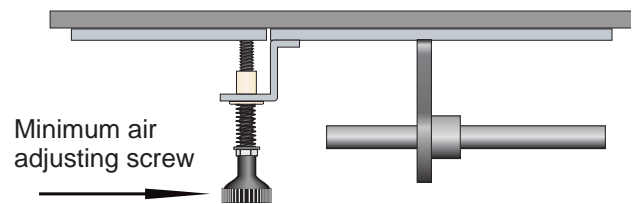

Remote Control Option

This stove has the option of remote control.

Fitting the Remote Control Motor

At the rear of the appliance you will see the motor fitting bracket. This incorporates a magnet and the mechanism friction plate.

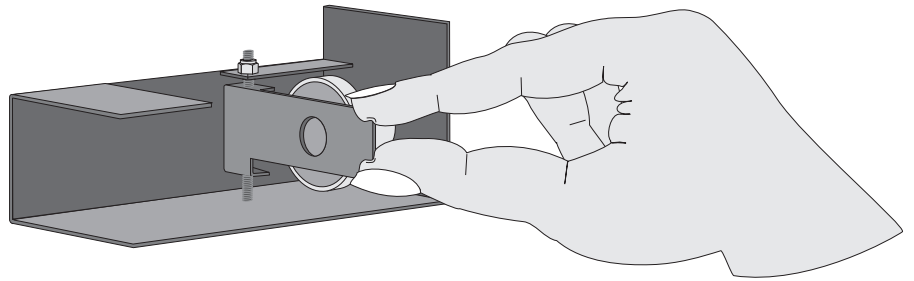

The friction plate is hinged. To fit the motor this friction plate needs to be detached from the magnet and swung to the left.

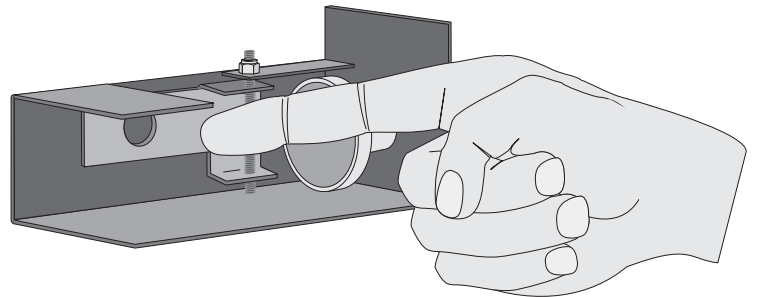

The motor can now be slipped into place. The magnet retains the motor.

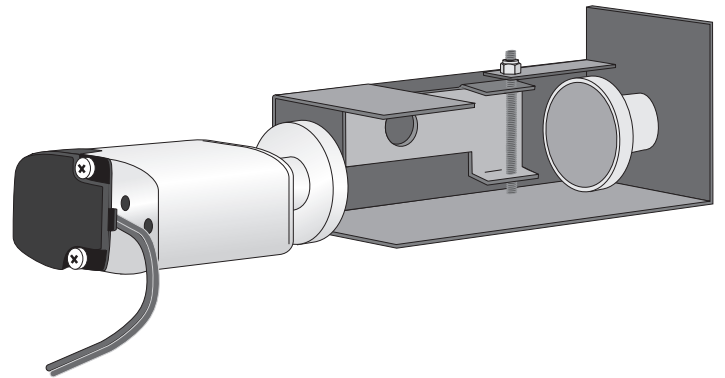

Connect the electrical lead to the receiver box and place the receiver box in its holder.



For full operating instructions for the remote control see the Remote Control Guide.

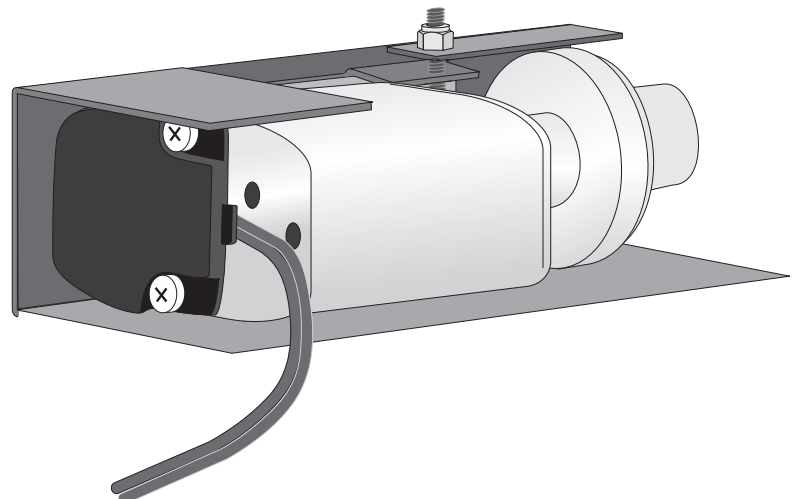

Commissioning Check List

Mark box when completed



Inspect the door and glass seals and ensure all handle latches are adjusted correctly, procedure in the operating instructions.

Check baffle is installed correctly and that the riddling mechanism is operating.

Ensure that the fire responds to the operation of the controls and that there are no visible emissions of the combustion products into the room.

Instruct the user on the use of the tools, operation of the appliance and the summer shut down procedure. Information in the operating instructions.

Instruct the user never to operate the stove with the furnace door open and that the user is aware of the requirement of a suitable fire guard where children, the old or infirm may come into contact with the appliance.

Hand over the installation instructions, operating instructions and completed warranty form to the user. Remind the owner to return the warranty form for registration.

Complete the Stoves Registration Form and Pass to User for Registration

Euroheat, Efel and Nestor Martin have a policy of continual research and development and reserve the right to modify its appliances without prior notice.

We make every effort to ensure that the information provided in this document is correct and accurate at the time of printing. Continued updates occur to adapt documents to customer requirements and appliance changes. For the latest editions of all Euroheat documentation visit our web site

www.euroheat.co.uk.

We would request that you inform Euroheat of information which you feel is not provided in this document which would assist other users in the future.

The Euroheat Technical Team

Welcome to the world of real Stoves

Euroheat Technical Team