

**CE** This product complies with the EMC requirements of the European Community.



Do not dispose of electrical appliances as unsorted municipal waste, use separate collection facilities. Contact you local government for information regarding the collection systems available. If electrical appliances are disposed of in landfills or dumps, hazardous substances can leak into the groundwater and get into the food chain, damaging your health and well-being.

Manufacturer: TechnoPLAS(SHENZHEN)CO.,LTD  
Manufacturer A Building TechnoPLAS Ind., Sheng Bao Road,Kangle community,  
Address: Nanwan Sreet,Longgang District,Shenzhen,China. 518112

**MUJI**  
無印良品

**Air Purifier** **Household Use**  
Model MJ-AP1GL

## User's Manual

- Thank you for purchasing this product.
- Please read this manual before use.
- Please keep this manual in a safe place for future reference.

Index	Page
Package Contents	1
Parts Names	2
Safety Advice	3-4
Warnings	5-7
Cautions	7
Before Use	8-10
How to Set Up	11
Specifications	12
How to Use/Explanation of Indicators	13-14
Operating Modes	15-16
Sensors	17
How to Clean the Dust Sensor	18
Air Purifier 360° Deodorizing Dust Collector Filter	19
How to Clean the Filter	20
How to Reset the Filter Cleaning Sign	21
Changing Filters	21
Care & Maintenance	22
FAQs	23-25

## Package Contents



..... **Body**



..... **360° Deodorizing Dust Collector Filter**

\* At time of purchase, the filter is in a plastic bag, stored inside the body.



..... **Filter Start Date Use Label**

\* The label is packed with the filter.  
\* Write the date of first use and stick onto the filter.



..... **Power Cord**



..... **User's Manual (this document)**

### ★Points to follow for long term use

**Have you noticed any of the following?**

- The purifier doesn't work, even if the power is turned on.
- Power supply is interrupted when the cord is twisted.
- Unusual sounds during operation.
- Warped or unusually hot product housing.
- Other irregularities or malfunctions.



**Discontinue Use**

In any of these cases, immediately discontinue use. Unplug the power plug from the socket and consult your retailer.

## FAQs

Problem	Solution	Page
<b>Black powder leaking from the filter.</b>	<input type="checkbox"/> <b>It is powder from the active carbon inside the filter.</b> ▶ It is not harmful to humans but when cleaning the filter, please lay newspaper on the ground.	P.21
<b>During operation, there is a noise other than that of the air blowing.</b>	<input type="checkbox"/> <b>Select Manual mode and change the air volume. Is there a change in the noise when the operating mode changes?</b> ▶ Please check "How to Use" and "Operating Modes". It is possible there is a rotating sound when fan mode is in operation, so please check the specified sound levels. Please consult the store where it was purchased from.	P.8
<b>The indicator light dimmed suddenly.</b>	<input type="checkbox"/> <b>When nothing is pressed for more than 1 second, the indicator light will dim.</b> ▶ Please check "How to Use".	P.13-14
<b>I can't change operating modes.</b>	<input type="checkbox"/> <b>Is child lock on?</b> ▶ Please check "How to Use".	P.13
<b>The smell won't go away.</b>	<input type="checkbox"/> <b>The deodorizer can remove smells to a certain extent.</b> * It is possible that not all smells can be removed depending on the environment. ▶ Remove the 360° Deodorizing Dust Collector Filter and dry it out in the sun where there is good wind flow, for half a day.  <input type="checkbox"/> <b>It does not necessarily remove smells that are always present (smells from pets, building materials etc).</b> ▶ If these smells are not removed completely, please use the product as well as ventilate the room.	
<b>The child lock indicator is flashing and the product stopped functioning.</b>	<input type="checkbox"/> <b>Is the filter cover inserted correctly?</b> ▶ Please check how to insert the filter cover.	P.9
	<input type="checkbox"/> <b>The product has detected an error and has stopped functioning.</b> ▶ Please check "How to Use" and press the power button following the steps below. <1st step> → Turn the power OFF. <2nd step> → Turn the power ON and operate normally. If it still does not function even after following the 2nd step, please consult the store where this was purchased.	P.14
<b>Foreign object enters the fin guard.</b>	<input type="checkbox"/> <b>Turn the machine off and unplug the power cord.</b> ▶ Remove the filter, and then take out the foreign object.	

## Parts Names

### Body

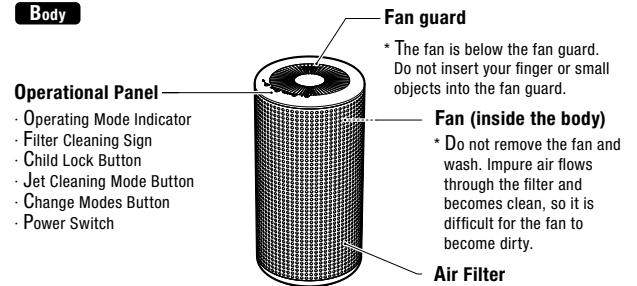

### Back of Body

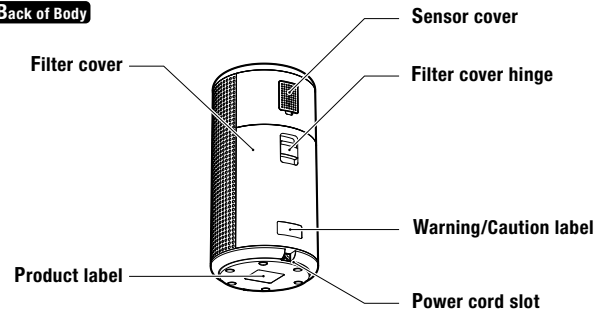

### Power Cord

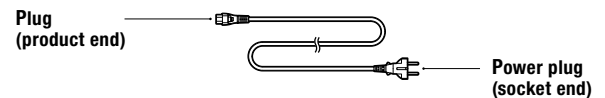



## Safety Advice

### Please be sure to follow the Safety Advice.

Please read the Safety Advice carefully before usage and use correctly. This manual contains points for caution so that the product can be used correctly in order to prevent causing accidental injuries or harm to the user of this product and others.

### Explanation of Signs

 **Warning** Indicates a hazard with a medium level of risk which, if not avoided, could result in death or serious injury.

 **Caution** Indicates a hazard with a low level of risk which, if not avoided, could result in minor or moderate injury or damage to property or furniture.

### Explanation of Symbols

 **Prohibited** This symbol indicates never to do this.

 **Must follow** This symbol indicates you must do this.

Problem	Solution	Page
The air volume changes without any manual operation.	<input type="checkbox"/> <b>Check the current operating mode. If it is in auto mode, it will automatically change if dust or smell is detected.</b> ▶ Please check "Operating Modes".	P1516
A strong volume of air started blowing.	<input type="checkbox"/> <b>Did you select the Jet Cleaning Mode?</b> This mode cleans the air on a high level in a short time. ▶ Please check "Operating Modes". Please be sure a suitable operating mode is selected.	P1516
Even though it is in Auto mode, it doesn't respond to dust or smell.	<input type="checkbox"/> <b>Is the sensor obstructed by the wall or other objects?</b> ▶ Please check "How to Set Up". If it is obstructed, please remove the obstruction. If there is no obstruction, please clean the sensor at the back of the body.	P11 P13
	<input type="checkbox"/> <b>What level of sensitivity is the sensor set to?</b> ▶ Please check "Changing the sensor's sensitivity". You can choose from Mild or Sensitive.	P17
There is a smell coming from the filter.	<input type="checkbox"/> <b>Is the filter new? There may be a faint sweet smell from the active carbon in the filter.</b> ▶ As high range active carbon is used, it may emit a sweet smell when it is first used. Usually it will take about 1 week for the smell to gradually lessen.	P19
	<input type="checkbox"/> <b>Did you use the product when there were many different smells emitted temporarily from many people smoking, cooking BBQ etc?</b> ▶ As the filter absorbs smells, it will temporarily store it up. It will gradually reduce as the product is in operation.	
	<input type="checkbox"/> <b>Did you move it from another room?</b> ▶ It is possible it smell like the room it was used in before. The smell will gradually reduce as the product is in operation.	P21
How often should the filter be changed?	<input type="checkbox"/> <b>It is recommended the filter is changed every year.</b> ▶ Please check the date when the filter was first used. It has been a year, please change to a new filter.	P20
The filter cleaning sign won't turn off.	<input type="checkbox"/> <b>Did you reset the filter change sign?</b> ▶ Please reset the filter change sign.	P21

## FAQs

Problem	Solution	Page
<b>Power doesn't turn on.</b>	<input type="checkbox"/> <b>Is the power plug plugged in correctly?</b> Please check the following that it is plugged in correctly. <ul style="list-style-type: none"> <li>▶ Connection between power code slot (of the body) and the plug (product end). <span style="float: right;">▶ P.10</span></li> <li>▶ Connection between the power plug and socket. <span style="float: right;">▶ P.10</span></li> </ul>	
	<input type="checkbox"/> <b>Are the indicators on the operating panel on?</b> Be sure to press the power button to operate. <ul style="list-style-type: none"> <li>▶ After reading and checking the section "How to Use", turn the ON/OFF button if necessary. <span style="float: right;">▶ P.14</span></li> </ul>	
	<input type="checkbox"/> <b>Is the child lock on?</b> Turn off the child lock. <span style="float: right;">▶ P.13</span>	
	<input type="checkbox"/> <b>Is the filter cover on correctly?</b> Check how to re-attach the filter cover. <span style="float: right;">▶ P.9</span>	
	<input type="checkbox"/> <b>Is the filter inserted correctly?</b> Check how to insert the filter. <span style="float: right;">▶ P.9</span>	
	<input type="checkbox"/> <b>Is there a power outage in your area?</b> ▶ Wait until the power supply returns.	
	<input type="checkbox"/> <b>Is the power breaker on?</b> ▶ Turn on the breaker.	
<b>There is no air blowing. There is no change in air volume. The air volume has decreased from when it was first purchased.</b>	<input type="checkbox"/> <b>Did you remove the filter from the plastic bag and inserted it in?</b> ▶ At the time of purchase, the filter is in a plastic bag. Remove from plastic bag and use. <span style="float: right;">▶ P.8</span>	
	<input type="checkbox"/> <b>Is the filter inserted properly?</b> ▶ Check if it is inserted properly. <span style="float: right;">▶ P.9</span>	
	<input type="checkbox"/> <b>Is the filter dirty?</b> <b>The amount of dirt will affect the air volume.</b> ▶ Please clean the filter. If there is no improvement, the filter needs to be changed. <span style="float: right;">▶ P.20</span>	
	<input type="checkbox"/> <b>Is the operating mode in Auto mode?</b> ▶ Please check the "Operating Modes". ▶ Press the Change Modes button to check that it is possible to change operating modes. <span style="float: right;">▶ P.15/16</span>	

### In order to use safely:

If any of the following occurs, stop usage immediately and contact the store where it was purchased from.

**Stop usage immediately if there are any irregularities such as unusual sounds, smell or heat.**  
Not doing so may cause malfunction or fire.

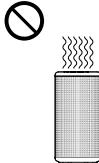

**Do not insert foreign objects or your finger inside the guard or moving parts.**  
This may cause injury.

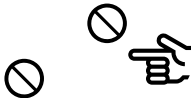

**Stop usage immediately if the fan is rotating abnormally or if there are other abnormalities.**  
Not doing so may cause malfunction or fire.

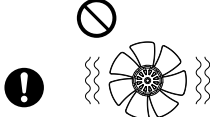



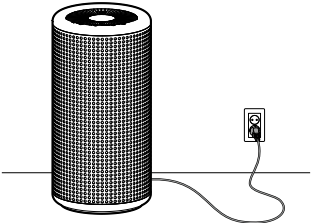



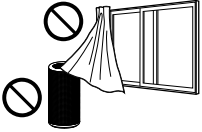



**Do not use on unstable locations or next to dangerous objects.**  
This may cause injury if it falls over.



**Do not use near objects such as curtains that will block the wind flow.**  
It may get caught in the curtain, or the filter or air diffuser may become blocked causing an accident or injury.



## Warnings

-  **Do not damage the power cord or plug.**  
Damaging, altering, forcefully twisting, pulling or placing heavy objects on the cord can cause electric shock or fire due to short circuit.
-  **Do not use if the power plug or cord becomes damaged, hot or loosely plugged into the socket.**  
This may cause fire, electric shock, injury or short circuit.
-  **Do not use on voltages over 220-240V or over the specified ratings for the socket or wiring appliances.**  
Using on multiple sockets over the specified ratings can cause it to heat up and lead to fire.
-  **Do not unplug with wet hands.**  
Wet hands on the electric plug can cause electric shock.
-  **Insert the plug fully until the base.**  
If it is not plugged in fully, electric shock or heat can cause a fire.
-  **Stop usage immediately and unplug if there are any abnormalities or malfunction.**  
Not doing so may lead to smoke, fire or electric shock. Please consult the store where it was purchased.  
**<Abnormalities/Malfunction>**
  - Moving the electric cord causes it to stop operating.
  - During operation, there are unusually large sounds or it moves violently.
  - The product is unusually hot or there is a burnt smell.
-  **Unplug from socket if not used for long periods.**  
Deterioration of insulation can cause a fire.
-  **Regularly clean the dust from the electric plug.**  
When dust accumulates, it can deteriorate insulation due to moisture, causing a fire.
-  **When cleaning, inspecting or moving the product, be sure to turn off the power and unplug.**  
Sudden movements can lead to electric shock or injury.
-  **Do not insert foreign objects such as your finger or metal objects into the air outlet, filter or openings inside the body.**  
Touching the inside can cause electric shock or injury.

## Care & Maintenance

Turn off the power and remove the plug from the socket. Vacuum the dust around the body of the product with a vacuum cleaner nozzle. Gently wipe with a soft cloth.

### 1 Remove the plug from the socket.

\* Be sure to unplug from the socket before starting.

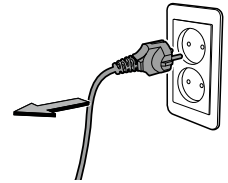

### 2 Vacuum the dust around the body of the product. Gently wipe with a soft cloth.

Please see **P.20** on how to clean the inside and the filter.

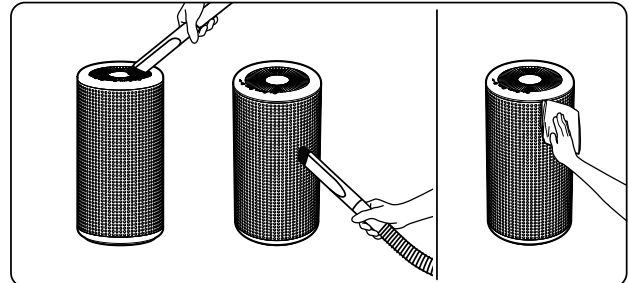

\* Be careful not to damage the surface.

### Do not use the following to clean the product.

(Benzine, thinners, other solvents or polishing powder)

\* This can cause scratches, discoloration or cracks.

## How to Reset the Filter Cleaning Sign

Turn off the power and press the Jet Cleaning Mode button for more than 2 seconds until it beeps. The filter cleaning sign will turn off and the timer will be reset.

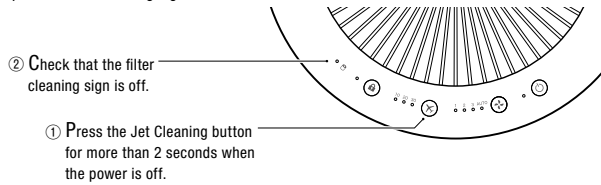

## Changing Filters (Ideally once a year)\*1

### When to change filters

The time to change filters depends on how and where you use the product. You should aim to change it every year.

If it is being used in areas where the air is not clean, you may need to change it earlier.

- When changing filters, lay newspaper underneath so that dust does not spread around.
- Dispose of the old filter according to your local area's disposal rules.

**Main materials of the filter** .....Polypropylene non-woven fabric, polyester non-woven fabric, rayon, active carbon, pulp etc

- Depending on the environment in which it is used in, the filter may start to emit a smell within a few weeks or months, so you may need to change the filter.
- The filter is a consumable item so it will incur a cost even if it is within the warranty period.

### About changing filters



To buy a replacement filter, please go to the store where you bought the product.

(Product Name: 360° Deodorizing Dust Collector Filter Model: MJ-AP1-FL)







\*1 When using Jet Cleaning mode once per day.

- ⊘ **Do not disassemble, repair or alter the product.**  
Heat or irregular operation may lead to electric shock or fire.
- ⊘ **Do not wet or run water over the product.**  
This may lead to electric shock or fire due to a short circuit.
- ⊘ **Do not let children use it alone or place in an area where young children can reach.**  
This may lead to electric shock or injury. Be especially careful with babies and infants.
- ⊘ **Do not use chlorine or acidic detergents.**  
Detergents emit poisonous gases which may be harmful to your health.
- ⊘ **Do not use near combustibles, lighted cigarettes or incense.**  
It may cause it to ignite and catch on fire.
- ⊘ **Do not operate when using pesticides that emit smoke.**  
Chemical substances that have accumulated is released through the air diffuser which may be harmful to health.  
After the use of pesticides, be sure to ventilate the room sufficiently before operating the product.
- ⚠ **Ventilate the room when using the product together with combustible appliances.**  
Not doing so may lead to carbon monoxide poisoning.  
Even if the product is in operation, it will not remove carbon monoxide.
- ⊘ **Do not use in the following locations.**  
This may lead to electric shock, fire or other damages.
  - Unstable or high places.
  - In the bathroom or where there is water, high temperatures or high humidity.
  - In the kitchen or places where there is oil.
  - Places where there might be leakage or use of oil or burnable gases.
  - Places where there are corrosive gases or dust from metallic objects.
  - Places where there is direct wind on plants or animals.
  - Places with direct heat such as a heater.
- ⊘ **Do not wipe with benzene or thinners or use pesticides.**  
This may cause cracks leading to injury, or short circuit causing electric shock or fire.

## Warnings

-  **If using near pets, be careful that they don't urinate on the product or chew on the power cord.**  
This may lead to electric shock or fire.
-  **When unplugging from the socket, pull from the plug.**  
Not doing so may lead to electric shock or fire due to damage or short circuit.
-  **Do not obstruct the air outlet and filter with laundry, cloths or curtains.**  
This may lead to poor air circulation causing heat or fire.

## Cautions

-  This appliance can be used by children aged from 8 years and above and persons with reduced physical, sensory or mental capabilities or lack of experience and knowledge if they have been given supervision or instruction concerning use of the appliance in a safe way and understand the hazards involved. Children shall not play with the appliance. Cleaning and user maintenance shall not be made by children without supervision.
-  **Do not sit or lean on the product.**  
It may cause the product to fall over and lead to injury. In case it falls over, unplug from socket.  
Be especially careful when using it in homes where there are young children.
-  **Do not turn the product on its side.**  
This may lead to injury or damage.
-  **When moving the product, turn off the power and carry it tightly.**  
Dropping the product or letting it slip and fall can lead to injury.
-  **Do not use for special purposes such as preserving artwork or technical documents or commercial purposes.**  
This may lead to deterioration of the quality of preservation items.
-  **During operation, do not move the product.**  
This may lead to injury or malfunction.
-  **Keep hair away from the fan guard.**  
This may lead to hair getting caught or malfunction.

## How to Clean the Filter

### The Filter Cleaning Sign and How to Clean the Filter

Based on the timer located inside the body, when the period of operation reaches 500 hours (approx. 3 weeks), the orange Filter Cleaning Sign will light up. When this lights up, please clean the area surrounding the filter in order to maintain the product's functions.

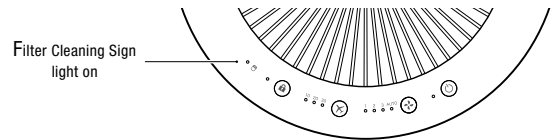

**1** Remove the filter following the steps on P.8.

**2** Vacuum dust inside the body and around the filter.

- \* Lay newspaper underneath so the dirt from the filter doesn't spread to other areas.
- \* Be careful not to damage the surface of the filter.

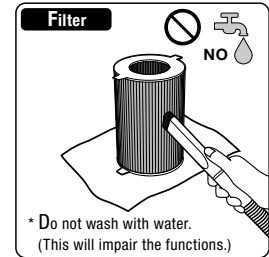
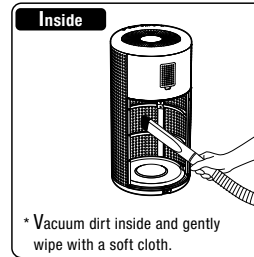

**3** Insert the filter following the steps on P.9.



## Air Purifier 360° Deodorizing Dust Collector Filter

**Granulated active carbon (deodorizer)** is placed in between **non-woven fabric filters (dust collector)** and pleated into a all-in-one dust collector and deodorizing filter.

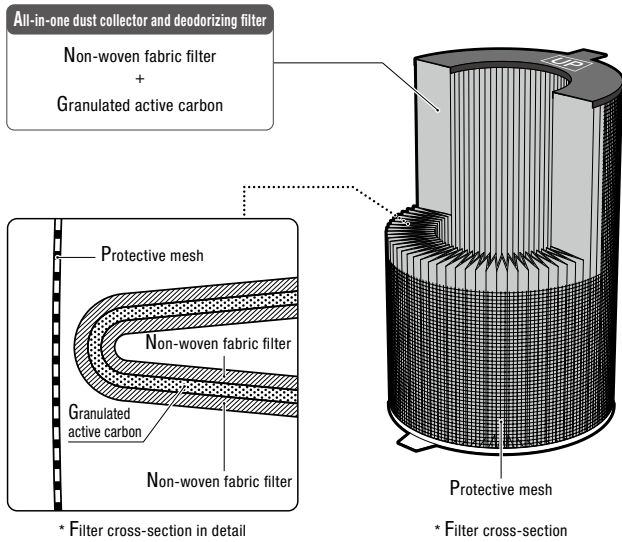

### When the deodorizer becomes less effective...

Revive the deodorizer by drying it out in the sun where there is good wind flow, for half a day. Do not wash with water.

\*The above does not guarantee that the deodorizer will return to its original new state.

## Before Use ① Removing/Inserting the filter

### 1 Open the filter cover

**a** Press and hold down the filter cover hinge.

**b** Pull the cover in the direction of the arrow shown.

**c** Remove the cover in the direction of the arrow shown.

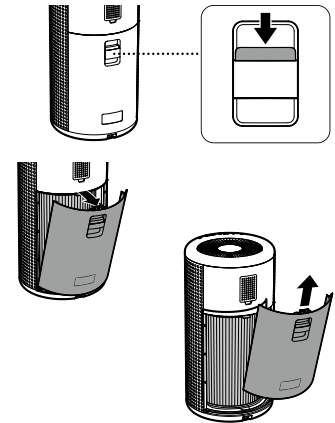

### 2 Take the Filter and Filter Start Date Use Label out from the plastic bag. Stick the Filter Start Date Use Label on the **UP** side as shown.

\* Cut the plastic bag with scissors.

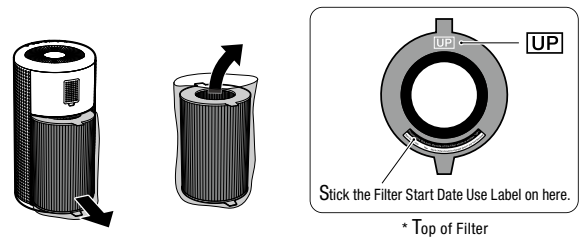

**3 Insert the filter into the body.**

Insert the filter into the body with the pull tab facing the front.

\* There is a top and bottom to the filter. Insert the filter with **UP** facing the top, and push all the way in.

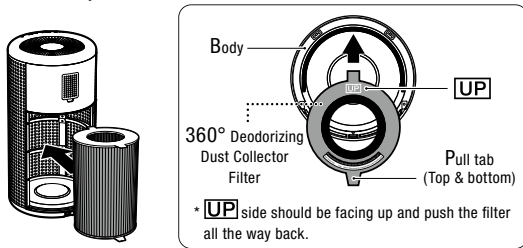

**4 Replacing the filter cover.**

\* If the filter or filter cover is not inserted correctly, the product will not function.

**d** Insert the bottom tab of the filter cover into the tab slot of the body.

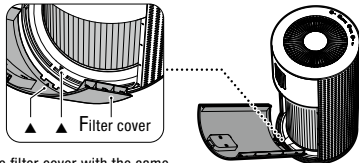

\* Match the ▲ mark of the filter cover with the same mark on the body.

**e** Push the filter cover hinge down in the direction of the arrow shown to close.

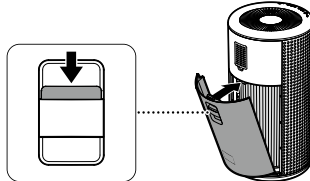

**How to Clean the Dust Sensor**

When the lens that detects dust becomes dirty with moisture, nicotine from cigarettes etc, it reduces the level of sensitivity. Please clean it regularly as shown below, **b** vacuum the surrounding dust with a vacuum cleaner, **c** remove dirt with a dry cotton bud.

\* Recommended cleaning every 3 months.

**a** Remove the sensor cover.



**b** Use a vacuum cleaner to remove the surrounding dirt that is covering it.

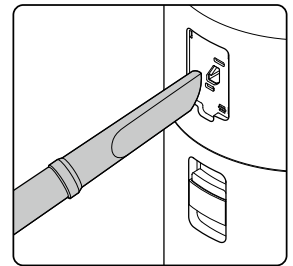

**c** Wipe the top left side of the lens with a dry cotton bud.

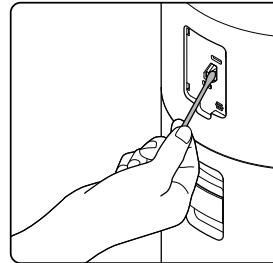

**d** Re-attach the sensor cover after cleaning.

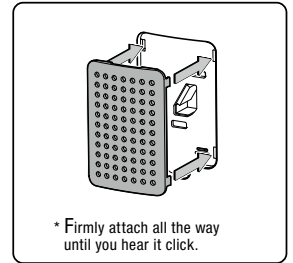

## Sensors

This product is equipped with a dust sensor which detects dirt in the air and a smell sensor which detects smells in the room.

In Auto mode, when the sensors detect dust or smell, it will control the air volume accordingly.

\* The sensors only operate in Auto Mode. Please refer to **P.16**

### Easily detectable by the dust sensor

House dust (dust, corpse and faeces of ticks, pollen, spores of mold), cigarette or incense smoke, pet hair

### Easily detectable by the smell sensor

Cigarette, incense, make-up, alcohol, sprays, pets, cooking/food odours

### Changing the sensor's sensitivity (Set on Mild at time of purchase)

When in Auto mode, the rotation of the fan is finely controlled depending on the monitoring status of the 2 sensors. The sensitivity level of the sensor can be chosen from the normal setting of Mild, or a higher sensitivity level of Sensitive. When you want to change the sensitivity level higher during Auto mode, use the Sensitive setting. To change the sensor's sensitivity level, press the Jet Cleaning Mode button and Change Modes button at the same time for more than 2 seconds, while the power is turned off.

\*Please refer to the diagram below to change the sensor's sensitivity level.

#### When changing to Mild

The buzzer will sound "Beeeep, Beep Beep"

#### When changing to Sensitive

The buzzer will sound "Beeeep, Beep"

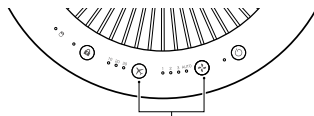
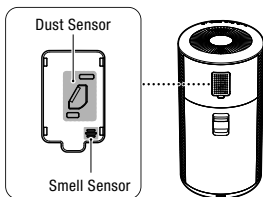

To change the sensor's sensitivity  
Press these 2 buttons at the same time for over 2 seconds while the power is OFF.

\*Unplugging the product will reset the sensor to Mild

## Before Use ② Connecting the power cord

- 1 Connect the power cord.**  
Insert the power cord into the slot of the body.

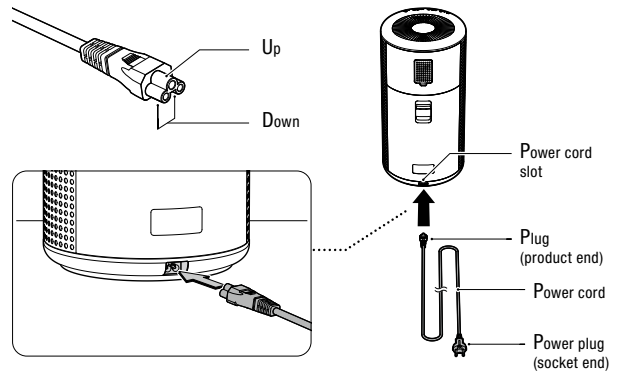

- 2 Connect the power plug to the socket.**

- a** Insert power plug into socket.  
\* The product will beep.

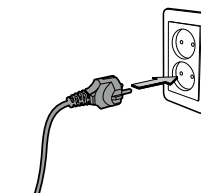

\* Please insert fully to the end.

- b** After inserting into socket as shown, it will be ready to use.

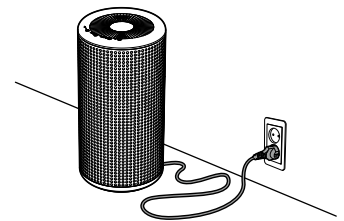

## How to Set Up

To utilise the functions of the product at its optimum, please set up at a suitable distance from the wall.

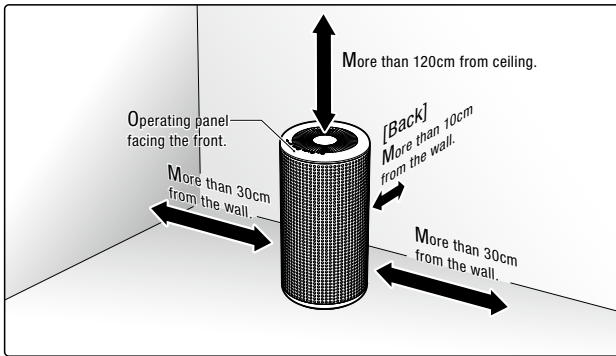

Placing in the following locations will not enable the product to function at its optimum.

Set up the product in a place where there is good air circulation in the room.

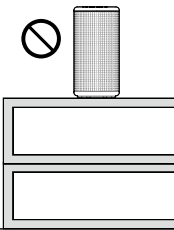

\* Do not place in high areas as this will reduce the efficiency of absorbing the air around the ground.

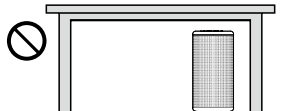

\* Do not place under a table or where the air outlet will be blocked.

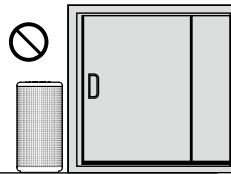

\* Do not place next to furniture or where the filter will be blocked.

### Manual Mode Indicator



### Auto Mode

This mode automatically controls the air volume depending on the condition of the air in the room. The 2 sensors which detect dust and smell regularly monitors the air condition **P.17**. When dirt (dust or smell) is detected, it will clean the air accordingly. When it doesn't detect any dirt in the air, it will repeat the cycle of <Idling > Manual Mode [Air Volume 1]>.

#### Idling Mode during Auto Mode Operation

The Idling mode which operates only in Auto mode stops the air purifier fan from rotating, while keeping the upper fan rotating slowly in order to circulate air that is required for the sensor detectors. This mode operates at the lowest energy consumption level at approximately 4W.

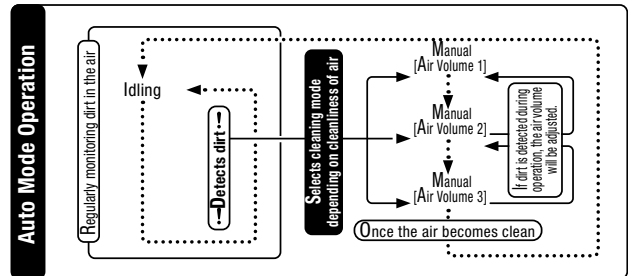

## Operating Modes



### Jet Cleaning Mode

This mode provides the optimum level of air flow at the highest speed, efficiently purifying the air in the room. It is especially effective to use before/after cleaning, after ventilation, before leaving the room, after cooking to remove strong odors such as from a BBQ. Also, you can choose from continuous operating time of 10, 20 or 30 minutes. When the jet cleaning mode finishes, it will return to the previous operating mode.

\* To cancel the jet cleaning mode, press the Change Modes Button .

#### Remaining time indicator during Jet Cleaning Mode



Display at the start of Jet Cleaning Mode			
30 minutes	30 minutes	20 minutes	10 minutes
<b>Jet Cleaning</b>	<b>20 minutes</b>	<b>10 minutes</b>	<b>5 minutes</b>
<b>Manual Mode Air Volume 3</b>	<b>5 minutes</b>	<b>5 minutes</b>	<b>2.5 minutes</b>
<b>Manual Mode Air Volume 2</b>	<b>5 minutes</b>	<b>5 minutes</b>	<b>2.5 minutes</b>

When the jet cleaning mode finishes, it will return to the previous operating mode.

### Manual Mode

You can choose from 3 levels of "Air Volume 1, 2, 3" providing a specific level of air purification. Also, manual mode can be used as an air circulator to improve the efficiency of air conditioners/heaters whilst purifying the air.

## Specifications

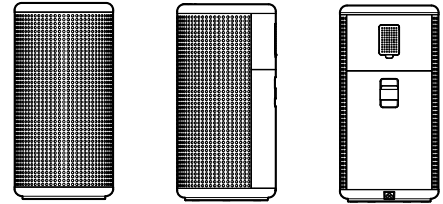

### Body<sup>\*1</sup>

Model	MJ-AP1GL				
Power Source	AC 220-240VAC 50Hz				
Suitable Floor Area (Ideal)	~49m <sup>2</sup> * <sup>2</sup>				
Cleaning Time	10min/32m <sup>3</sup> * <sup>2</sup>				
Operating Mode	Jet Cleaning	3	2	1	Idling <sup>*3</sup>
Total Air Volume	6.7m <sup>3</sup> /min	3.1m <sup>3</sup> /min	1.9m <sup>3</sup> /min	1.1m <sup>3</sup> /min	—
Energy Consumption	32W	10W	7W	4W	4W
Operating Noise Level	60dB	43dB	34dB	27dB	19dB
Product Measurement	W250×D250×H498 (mm)				
Product Weight	Approx. 6.0kg (Including filter)				

### Power Plug<sup>\*1</sup>

Cord Length	Approx. 2.0m	(Power cord is for AC 220-240VAC.)
-------------	--------------	------------------------------------

\*1 For use in Hong Kong and Europe.

\*2 Suitable Floor Area and Cleaning Time is based on "JEM1467" (during Jet Cleaning Mode).

\*3 Idling mode only functions during Auto mode.

\* This product uses an original "dual counter fan" to effectively clean the air of the entire room. "Total air volume" refers to the amount of air that flows through the 360° Deodorizing Dust Collector Filter that becomes purified and is released through the top air outlet.

\* The energy consumption value during Idling mode is measured when the indicator brightness is halved.

## How to Use/Explanation of Indicators

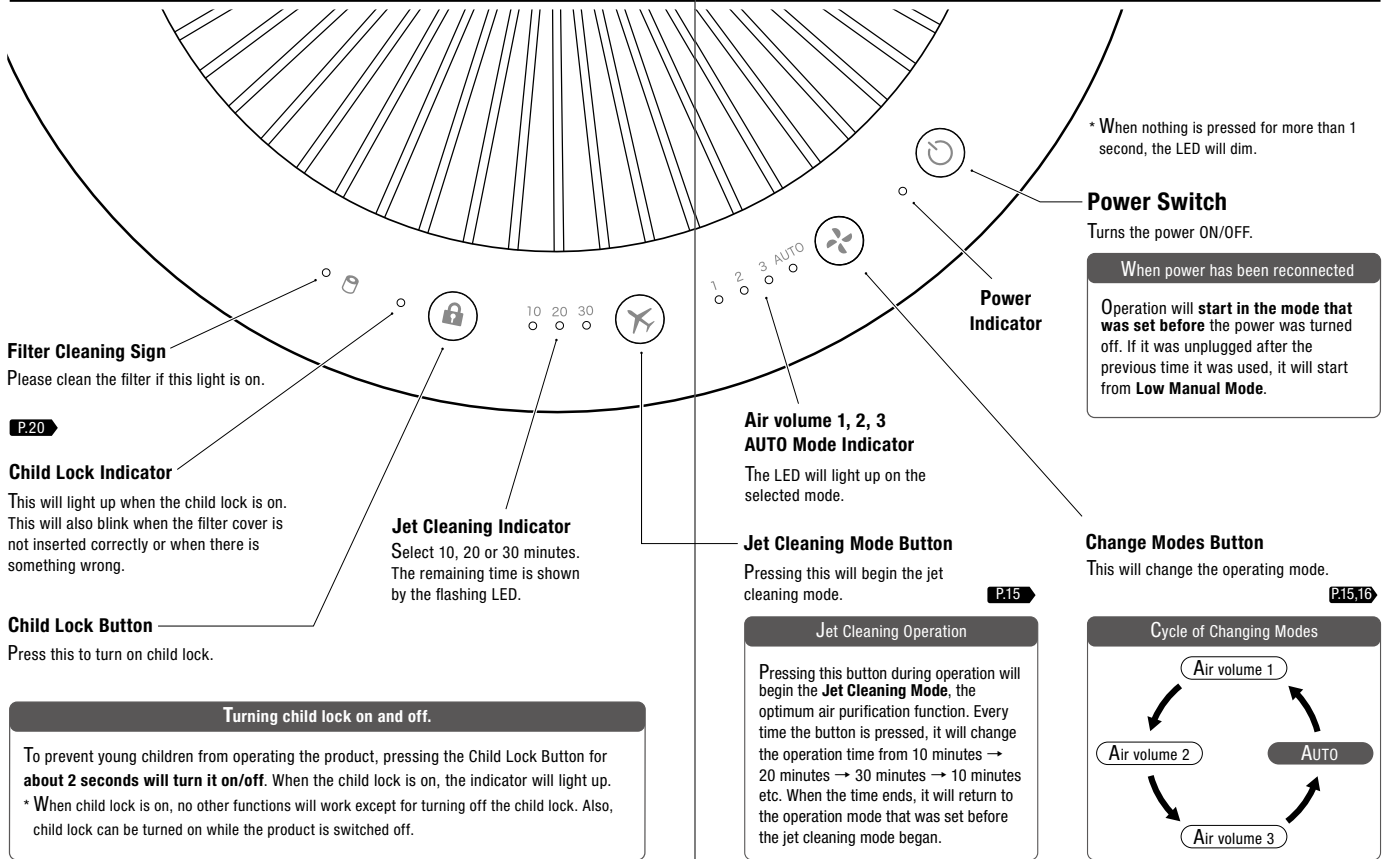

**Filter Cleaning Sign**  
Please clean the filter if this light is on.

P.20

**Child Lock Indicator**  
This will light up when the child lock is on. This will also blink when the filter cover is not inserted correctly or when there is something wrong.

**Child Lock Button**  
Press this to turn on child lock.

**Turning child lock on and off.**

To prevent young children from operating the product, pressing the Child Lock Button for **about 2 seconds will turn it on/off**. When the child lock is on, the indicator will light up.  
\* When child lock is on, no other functions will work except for turning off the child lock. Also, child lock can be turned on while the product is switched off.

**Jet Cleaning Indicator**  
Select 10, 20 or 30 minutes. The remaining time is shown by the flashing LED.

**Air volume 1, 2, 3 AUTO Mode Indicator**  
The LED will light up on the selected mode.

**Jet Cleaning Mode Button**  
Pressing this will begin the jet cleaning mode.

P.15

**Jet Cleaning Operation**

Pressing this button during operation will begin the **Jet Cleaning Mode**, the optimum air purification function. Every time the button is pressed, it will change the operation time from 10 minutes → 20 minutes → 30 minutes → 10 minutes etc. When the time ends, it will return to the operation mode that was set before the jet cleaning mode began.

\* When nothing is pressed for more than 1 second, the LED will dim.

**Power Switch**  
Turns the power ON/OFF.

When power has been reconnected

Operation will **start in the mode that was set before the power was turned off**. If it was unplugged after the previous time it was used, it will start from **Low Manual Mode**.

**Power Indicator**

**Change Modes Button**  
This will change the operating mode.

P.15,16

**Cycle of Changing Modes**

