



## Miiego – AL3 Wireless Headphones

ENGLISH User Manual

### QUICK-GUIDE

1-2-3 – go!:



- 1: Make sure the headset is charged and turned OFF.
- 2: Press and hold the big MFB Button on the headset (right ear pad) for about 7 seconds until the red and blue LED flash alternatively (pairing mode)
- 3: Activate Bluetooth on your mobile phone or device, and “seek for new device”. Find”AL3” on the list and press ”connect”.

If asked for a PIN-code press: 0000

Thank you for buying the **AL3 Wireless Headphones** from Miiego.

This unit uses Bluetooth wireless technology.

- Listen to and enjoy music wirelessly!
- Hands-free communication
- Useful rechargeable battery function

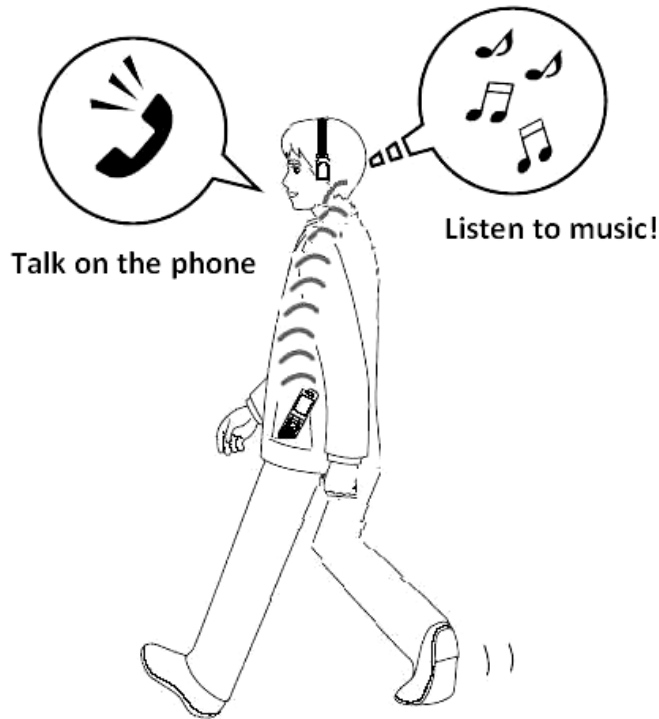

**Disposal of Old Electrical & Electronic Equipment (Applicable in the European Union and other European countries with separate collection systems)**

This symbol on the product or on its packaging indicates that this product shall not be treated as household waste. Instead it shall be handed over to the applicable collection point for the recycling of electrical and electronic equipment. By ensuring this product is disposed of correctly, you will help prevent potential negative consequences for the environment and human health, which could otherwise be caused by inappropriate waste handling of this product. The recycling of materials will help to conserve natural resources. For more detailed information about recycling of this product, please contact your local Civic Office, your household waste disposal service or the shop where you purchased the product.

### **About AL3 Wireless Headphones from Miiego**

AL3 is a stereo Bluetooth headset. It supports the following Bluetooth profiles:

A2DP	——	Advanced Audio Distribution Profile
AVRCP	——	Audio/Video Remote Control Profile
HSP	——	Headset Profile
HFP	——	Hands free Profile

## Bluetooth wireless technology

Bluetooth is a standard of close range radio-communication technology. Through Bluetooth technology, you can achieve the highest transmission rate among mobile phones, computer, printer, PDA and other devices.

The max. transmission range of Bluetooth Class II is 10 meters.

This headset can e.g. be connected to a *Bluetooth enabled* mobile phone, PDA, PC, tablet etc....

## Steps for the Bluetooth functions:

### 1. Overview

*Right Earpad:*

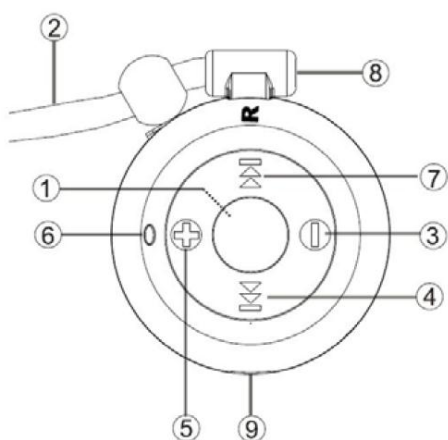

- 1) Multifunction button (MFB): Switch on/off the headset, answer, end and reject call, mute, voice dial and voice transfer, redial last number, pause and revert to play
- 2) Head band
- 3) – key: volume down
- 4) < key : previous song
- 5) +key: volume up
- 6) LED Indicator
- 7) > fast : next song
- 8) Built-in microphone
- 9) Charging port

### 2. Charging the headset

The first time you use the headset we advise you to fully charge the battery in order to ensure the best performance of the battery. The battery is a re-chargeable Lithium-Polymer battery.

#### ***Next time charging***

When you hear a warning tone of “beep” every 30 seconds, at the same time, the red light blinks. It means the battery is low on power and needs to be charged.

## Charging the battery with USB cable

Step1: Insert USB charging cable into USB port of PC.

Step2: Connect charging cable with the charging port of headset.

*When the red light is on, the headset is charging.*

*When the red light is off, the headset is charged fully.*

Step3: It takes about 2-3 hours to charge the headset fully.



### Warning:

1. The battery is recycled.
2. Do not dispose battery in fire, as it may cause explosion.

## ■ How to use

### 1. Switching the headset on / off

Function	Operation	LED indicator
Switch on	Press the MFB for 3-4 seconds, and release till the blue light blinks.	The blue light blinks quickly every 4 sec.
Switch off	Press the MFB for 3-4 seconds, and release till the red light blinks.	The red light blinks quickly every 4 sec.

## 2. Pairing with Bluetooth device

### 1) How to enter into pairing mode

Function	Operation	LED indicator
Enter into pairing mode	Make sure the headset is off. Press and hold the MFB for 7 seconds, and release when the red and blue light blink alternately	The red and blue lights blink alternately.

**Note:** The pairing mode will last 2 minutes, If the headset still can't pair with any Bluetooth devices after 2 minutes, it will switch into standby mode automatically.

## 2) Pairing with Bluetooth mobile phone

Please make sure your mobile phone has a Bluetooth function that can be used. Specific pairing procedures may vary with different mobile phone. Please refer to your mobile phone manual for further information.

Steps as follows:

- a) Please keep the headset and mobile phone in the range of 1 meter when pairing.
- b) Make the headset enter into pairing mode. (Make sure the headset is off. Press and hold the MFB for 7 seconds, and release when the red and blue light blink alternately)
- c) Start the Bluetooth function of mobile phone and search the Bluetooth devices. After searched, select "AL3" in the Bluetooth device list.
- d) According to indication, enter password or PIN No: "0000", and press the key of "Yes" or "confirmed".
- e) After successful pairing, select "AL3" in the Bluetooth device list. and press "connect".
- f) After successful connecting, the blue light of the headset blinks twice every 4 seconds. The headset is now connected to the mobile phone and ready to use.

### **Note:**

- ✧ If the pairing is not successful, please switch off headset firstly, and then re-pair according to the step a-f mentioned above..
- ✧ After pairing is successful, paired devices will remember each other. Unless pairing information is deleted because of new pairing, no need to pair when use next time.
- ✧ The headset will connect with the latest paired device. If you want to pair with other Bluetooth devices, please switch off the Bluetooth function of the current Bluetooth device, and then pair and connect it with the new Bluetooth device according to steps a-f mentioned above.

### **3) Pairing with Bluetooth transmitter**

You can enjoy music wirelessly through connecting the headset with a stereo Bluetooth transmitter,.

*Pairing steps as follows:*

- a) Keep the Bluetooth transmitter and headset in the range of 1 meter (3 ft.) when pairing.
- b) Make the headset enter into pairing mode ((Make sure the headset is off. Press and hold the MFB for 7 seconds, and release when the red and blue light blink alternately)
- c) Turn on the Bluetooth transmitter. It will search Bluetooth device automatically and start pairing.
- d) When the headset requests PIN No, the Bluetooth transmitter need to respond "0000" automatically
- e) After successful pairing and connecting, the blue (or red) light of headset blinks twice every 4 seconds and is now ready to use.

**Note:**

1. The pairing password of AL3 is "0000", so, the headset can't pair with the Bluetooth transmitter which pairing password is not "0000".
2. If the pairing is still not successful after trying several times, please refer to your Bluetooth transmitter manual carefully..

### 3. Making calls with the headset

Function	Status of headset	Operation	Indication tone
<i>Voice dial</i>	Standby mode	Press and hold the MFB for 3 sec, release the key when you hear the indication sound	A short tone
<i>Redial last number</i>	Standby mode	Press the MFB twice	A short tone
<i>Turn up volume</i>	Conversation mode	Short press or long press + key	When max. is reached you hear: "DU DU"
<i>Turn down volume</i>	Conversation mode	Short press or long press - key	Nothing
<i>Answer call</i>	Ringing	Short press the MFB	A short tone
<i>Reject call</i>	Ringing	Press and hold the MFB for 2 sec, and release the key until you hear the indication sound	A short tone
<i>End call</i>	Conversation mode	Short press the MFB	A short tone
<i>Switch conversation between headset and cell phone</i>	Conversation mode	Press and hold the MFB for 2 sec, release the key when you hear the indication sound	A short tone

#### Remarks:

- ✧ Not all mobile phones support all the functions listed above. Please refer to the instruction of your mobile phone.
- ✧ For some mobile phones, when you press the key of accepting a call on the mobile phone, the conversation will be sent to the mobile phone. At this time, you can switch the call to headset by using the conversation switch button or through operating on the mobile phone. Please refer to the instruction of your mobile phone for further information.

#### 4. Playing music

When the headset connects with the mobile phone or a Bluetooth transmitter which supports A2DP, you can enjoy music through the headset wirelessly..

Function	Status of headset	Operation	Indication tone
Volume up	Playing music	Short press or long press + key	When max. is reached you hear: "DU DU"
Volume down	Playing music	Short press or long press - key	nothing
Pause	Playing music	Short press the MFB	A short tone
Revert	Pause	Short press the MFB	A short tone
Last song	Playing music	Short press < key	A short tone
Next song	Playing music	Short press > key	A short tone

#### Remark:

- ✧ For some mobile phones, it happens when they are playing music, the music will transmit to the speaker of the mobile phone. E.g. iPhones. You have to choose "transmit the sound through Bluetooth" in the "setting" of music play interface, and then choose "AL3" in the device list, the music will be transmitted to the headset. Please refer to the instruction of your mobile phone for further information.
- ✧ Remote control the function of previous song/next song/pause/revert, your mobile phone needs to support AVRCP. Please refer to the instruction of your mobile phone or Bluetooth transmitter for further information.



## ■ Care and maintenance

Please read the following suggestions and instructions carefully, that will help you to fulfill any warranty obligations and to enjoy this product.

- ✧ Keep the headset dry and don't put it in a damp place, in case of effecting the interior circuit of the product
- ✧ Don't place the product under sunlight or in hot areas. High temperature will shorten the life of electronic devices, destroy the battery, or distort certain plastic.
- ✧ Don't expose the product in cold areas. This may damage the internal circuit board.
- ✧ Don't try to take apart the product. It may damage the product if you are not professional.
- ✧ Don't use intensified chemicals or detergent to clean the product.
- ✧ Don't scrap the surface with sharp things

## ■ Warnings

**To reduce the risk of fire or electric shock, do not expose this product to rain or moisture**

Do not place objects filled with liquids, such as vases, on or near the product. Do not place this unit in a place where it is exposed to humidity, dust, soot or steam, subject to direct sunlight, or in a car waiting at a traffic signal or the like. It may cause a malfunction. Do not put weight or pressure on the unit, as it may cause the product to deform during longer storage.

Listening with this product at high volume may affect your hearing. It is strongly advised to use precaution. Miiego Aps or any other supplier of the product cannot be held responsible for any hearing damage. It is the responsibility of the user/consumer to control the volume at a proper level. It is advised not to keep a high volume for at longer period of time. If you experience any discomfort while or after using the Bluetooth device, stop using it immediately. For traffic safety reasons, do not use the product while driving or operating motor driven vehicles.

**Keep away from animals and small children!**

Using the Bluetooth device may not function on all mobile phones, depending on radio wave conditions and location where the equipment is being used.

The Bluetooth word mark and logos are owned by the Bluetooth SIG., Inc. Other trademarks and names are those of their respective owners.

## ■ FAQs

- 1 Q: What does it mean when red indicator light is on ?  
A: Battery is low, needs to be recharged
  
  - 2 Q: Why is the red light not bright when charging?  
A:           a) Please make sure the charging device connects with headset. well  
  
              b) You didn't use the headset for a long time, the battery may dry up. At this time, you have to charge the battery for 30 minutes, and then the red light will be bright.
  
  - 3 Q: How far is the effective rang between the headset and mobile phone?  
A: According to the Bluetooth standard, the max. controllable range of Class2 headset is 10 meters. It varies under different conditions and environments.
  
  - 4 Q: Why can't my cell phone search and find the headset?  
A: The mobile phone will not find the headset if the headset and mobile phone are not under pairing mode, Make sure the headset is under pairing mode and within the effective working range, and then the headset can be paired and connected.
  
  - 5 Q: I can't hear the voice of the person I am talking to when making a call?  
A:           a) Make sure the headset has been switched on.  
  
              b) Make sure the volume is not too low or muted  
  
              c) Make sure the headset connects with the mobile phone correctly.  
  
              d) Make sure the distance between the headset and the cell phone is in the normal working scope.
  
  - 6 Q: Why is the voice not clear when having a phone call conversation?  
A: Make sure the mobile phone is in the strong signal area and in the function range of the headset.
  
  - 7 Q: Why can't I control the functions of pause, revert,           previous song and next song when playing music?  
A: This function needs that your Bluetooth device supports CP(Audio/Video Remote Control profile).
-

## ■ Specifications

<b>Bluetooth version</b>	Compatibility Bluetooth V2
<b>Bluetooth profile</b>	Headset, Hands free, HSP/ HFP/ A2DP/ AVRCP
<b>Frequency Range:</b>	2.4020 GHz - 2.4800GHz
<b>Effective range:</b>	10 meters in direct line
<b>Working time :</b>	Music: Up to 5 hours* Talk: Up to 7 hours*
<b>Standby time :</b>	Up to 150 hours*
<b>Battery:</b>	Built-in re-chargeable lithium-polymer battery
<b>Charging time :</b>	Approx. 2-3 hours
<b>Dimensions</b>	95*70*35 mm.
<b>Weight</b>	app. 45g

\*Time stated above may vary, depending on ambient temperature or conditions of use.

**Note:** This Bluetooth stereo headset complies with Part 15 of the FCC Rules. Operation is subject to the following two conditions: (1) This Bluetooth stereo headset may not cause harmful interference, and (2) it must accept any interference received, including interference that may cause undesired operation.



**Buy more accessories for your headset at:**

**[www.miiego.com](http://www.miiego.com)**