

20"
25"

MCLANE MOWER

Owner's Handbook Front Throw Reel Mower

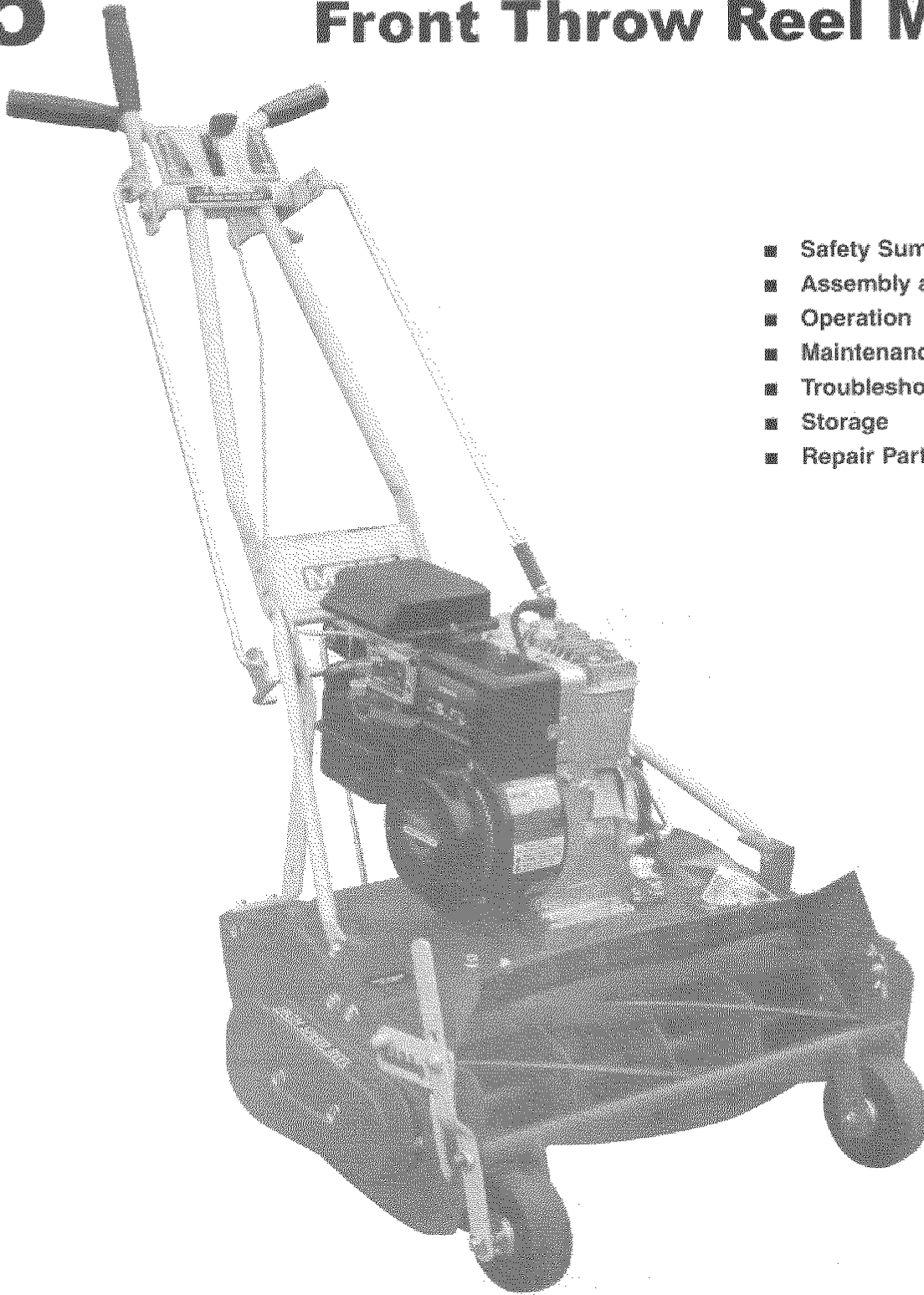

- Safety Summary
- Assembly and Adjustment
- Operation
- Maintenance and Servicing
- Troubleshooting
- Storage
- Repair Parts

MCLANE

MANUFACTURING
INC.

7110 East Rosecrans Ave.

Paramount, CA 90723

Telephone

(562) 633-8158 (323) 636-8336

Fax: (562) 602-0651

CONTENTS

Section Title	Page	Section Title	Page
SAFETY SUMMARY	3	MAINTENANCE AND SERVICING	10
FRONT THROW REEL MOWER FEATURES	4	General Recommendations	10
ASSEMBLY AND ADJUSTMENT	5	Cleaning the Cooling System	10
Tools Required	5	Cleaning the Engine	10
Unpacking	5	Lubrication	10
Assembly	5	Reel Maintenance	10
Clutch Control Rod Adjustment	6	Clutch Belt Maintenance	10
Grass Catcher Installation	7	Clutch Belt Replacement	10
OPERATION	7	TROUBLESHOOTING	11
Fuel and Oil	7	STORAGE	11
Engine Oil Recommendations	7	Mower	11
Fuel Recommendations	7	Engine	11
Cutting Height Adjustment	8	Other	11
Rear Axle Adjustment	8	FRONT THROW REEL MOWER PARTS	12
Operating Controls	9	HEAVY DUTY DROP-OUT REAR AXLE PARTS	14
Operating the Mower	9		
Starting the Mower	9		
Stopping the Mower	9		

NOTICE TO CUSTOMERS IN THE STATE OF CALIFORNIA.
THE ENGINE ON THIS UNIT IS NOT EQUIPPED WITH A SPARK ARRESTING MUFFLER.

- WARNING -

USE OR OPERATION OF THIS ENGINE ON ANY FOREST COVERED, BRUSH COVERED, OR GRASS COVERED LAND WITHOUT A STATE APPROVED SPARK ARRESTOR IN EFFECTIVE WORKING ORDER CONSTITUTES A VIOLATION OF THE LAW OF THE STATE OF CALIFORNIA.

NOTE: For repairs beyond the minor adjustments included in this manual, please contact your local Lawn Mower Service Center.

For engine service, see an Authorized Service Center for your engine type. Refer to the engine manual (provided separately) for more information.

TWO YEAR LIMITED WARRANTY

For two years from purchase (60 days for commercial use) McLane Manufacturing Inc., will replace for the original purchaser, free of charge, any part or parts, found upon examination by any factory-authorized service center, or by the factory in Paramount, California, to be defective in material or workmanship or both. All transportation charges on parts submitted for replacement under this warranty must be borne by purchaser. There are no other expressed warranties. Implied warranties, including those of merchantability and fitness for a particular purpose, are limited to two years from purchase and to the extent permitted by law. Any and all implied warranties are excluded. This is the exclusive remedy and liability for consequential damages. Any and all warranties are excluded to the extent exclusion is permitted by law. Some states do not allow limitations on how long an implied warranty lasts, and some states do not allow the exclusion limitation of consequential damages, so the above limitation and exclusion may not apply to you. This warranty gives you specific legal rights and you may also have other rights which vary from state to state. It is your responsibility to follow the maintenance instructions described in the owner's manual. Routine service (cleaning, blade sharpening) is your responsibility. Defect of engine is covered by manufacturer of engine.

McLane Manufacturing, Inc.

NOTE: Operator abuse and improper assembly of product is not covered by any written or implied warranty. Read your Owner's Manual carefully.

SAFETY SUMMARY

BEFORE USE

- **Read this Owner's Manual** and the engine manual (provided separately) **before** using your mower. Be thoroughly familiar with the locations of operating controls and proper use of the equipment.
- **Never** let children operate the mower.
- Keep children, pets and other persons away from the area of operation.

PREPARATION FOR USE

- Clear all stones, sticks, wire, bones and other foreign objects from the area to be mowed **before** starting and using the mower.
- **Do not** operate the mower while barefoot or wearing open sandals. Always wear suitable footwear, such as work boots.
- Check the fuel level **before** starting the engine. **Do not** fill the gasoline tank indoors, while the engine is running, or while the engine is hot. Clean spilled gasoline from the engine and surrounding area **before** starting the mower.
- For mowers equipped with an automatic drive, disengage the automatic drive mechanism or drive clutch **before** starting the engine.
- Use the mower **only** during daylight hours, or in good artificial light. **Never** use the mower in wet grass.

OPERATION

- **Never** adjust the cutting height while the engine is running.
- **Always** be sure of your footing while mowing. Keep a firm hold on the mower handle.
- **Do not** change the engine governor settings or overspeed the engine.
- **Do not** put hands or feet near or under rotating parts. Keep clear of the discharge opening whenever the engine is running.
- Stop the reel blade(s) by releasing the clutch lever whenever crossing gravel drives, walks or roads.
- If the reel blades strike a foreign object during use, turn the motor off **immediately** and disconnect the spark plug wire from the spark plug. Check the mower thoroughly for damage. Repair any damage before restarting and using the mower.

- If the mower starts to vibrate excessively during use, stop the engine **immediately** and disconnect the spark plug wire from the spark plug. Check the mower thoroughly to locate the cause of the vibration. Excessive vibration can be a sign of loose or worn parts or other trouble.
- **Always** stop the engine whenever you leave the mower unattended.
- **Always** stop the engine before cleaning the mower housing, and whenever making inspections or repairs.
- **Before** cleaning, inspecting or repairing the mower, make sure the reel and other moving parts are **completely** stopped. Disconnect the spark plug wire from the spark plug. Keep the plug wire away from the plug to prevent accidental starting.
- **Never** run the engine indoors.
- Turn the engine off and wait until the reel is **completely** stopped before removing the grass catcher or unclogging the discharge opening.
- **Always** mow across the face of slopes, **never** up-and-down. Use extreme caution when changing direction on slopes. **Do not** mow excessively steep slopes.
- **Never** operate the mower without the factory-installed guards, plates and other protective devices in place.
- **Always** keep washout ports and other mower housing service openings closed when mowing.

MAINTENANCE

- Check all reel and engine mounting bolts **regularly** for proper tightness. Keep all nuts, bolts, and screws tight to keep the mower in safe working condition.
- **Never** store the mower in a building or enclosed area with gasoline in the tank where fumes may reach an open flame or spark. Allow the engine to cool before storing in any enclosed area.
- To reduce fire hazard, keep the engine free of grass, leaves or excessive grease.
- Check the grass catcher **frequently** for wear or deterioration.

FRONT THROW REEL MOWER FEATURES

Notice to customers in the State of California.
The engine on this unit is not equipped with a
spark arresting muffler.

--WARNING--

Use or operation of this engine on any forest
covered, brush covered, or grass covered land
without a state approved spark arrestor in
effective working order constitutes a violation of
the law of the State of California.

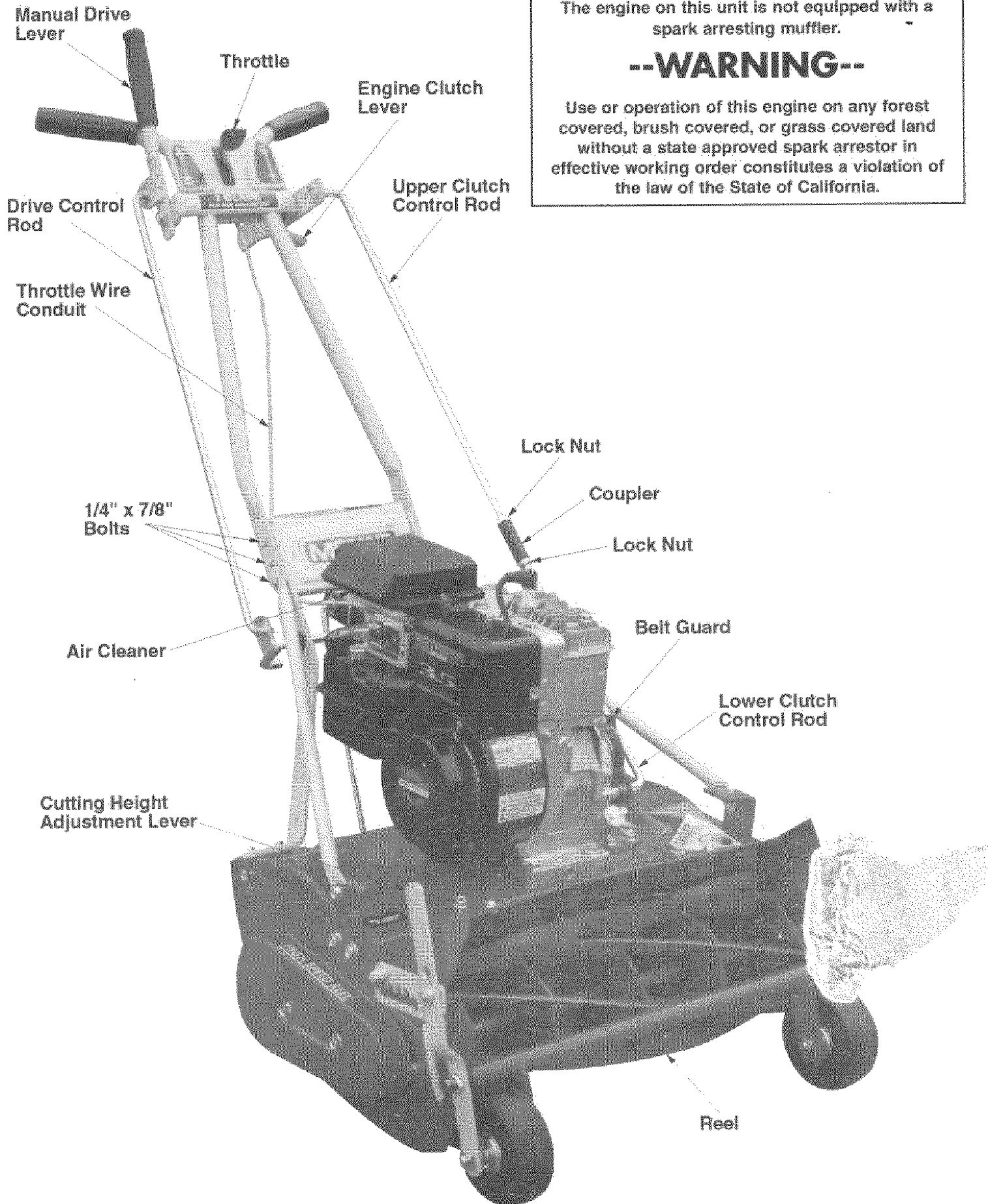

ASSEMBLY AND ADJUSTMENT

TOOLS REQUIRED

Pliers, Screwdriver, 7/16" Wrench, (11/16" Wrench needed to adjust Clutch Tension)

UNPACKING

The lawn mower is shipped fully assembled except for the handle, throttle control, drive control rod and clutch control rod. All items are packed and shipped in one container.

1. Open the carton.
2. Remove the grass catcher, handle assembly, drive control rod and upper clutch control rod.
3. Remove the cardboard packing material from the carton.
4. Cut the back panel of the carton, and fold down flat.
5. Roll the mower out of the carton.
6. Disconnect the spark plug wire from the spark plug, remove the hardware kit, then reconnect the spark plug wire to the spark plug.

ASSEMBLY

NOTE: Reference to left or right side of the mower is made from the user's position at the handle, facing forward.

1. Install the handle assembly:

NOTE: Six bolts and nuts are used to secure the handle assembly; two bolts and nuts are factory-installed, the remaining bolts and nuts are included in the hardware kit.

- A. Remove the bolt and nut securing the left-side handle brace to the lower handle and inner brace (see Figure 1).

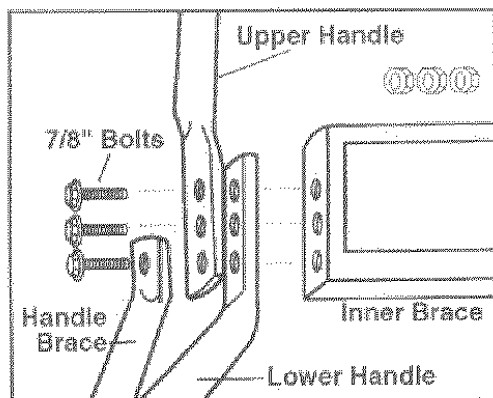

FIGURE 1: Use two factory-installed bolts and nuts, plus four bolts and nuts included in the hardware kit to install the handle.

- B. Position the upper handle between the handle brace and lower handle, aligning the three holes in the upper handle with the three holes in the lower handle. Reinstall the bolt removed in step A through the handle brace, upper handle, lower handle and inner brace. Reinstall the nut **FIN-GER TIGHT ONLY**.
- C. Repeat steps A and B for the right-side of the handle.
- D. Adjust the position of the upper handle as needed to align the holes in the upper handle with the holes in the lower handle; then install the remaining four bolts through the upper handle, lower handle and inner brace.

- E. Install one nut on each bolt, then tighten the nuts **SECURELY** (see Figure 2).

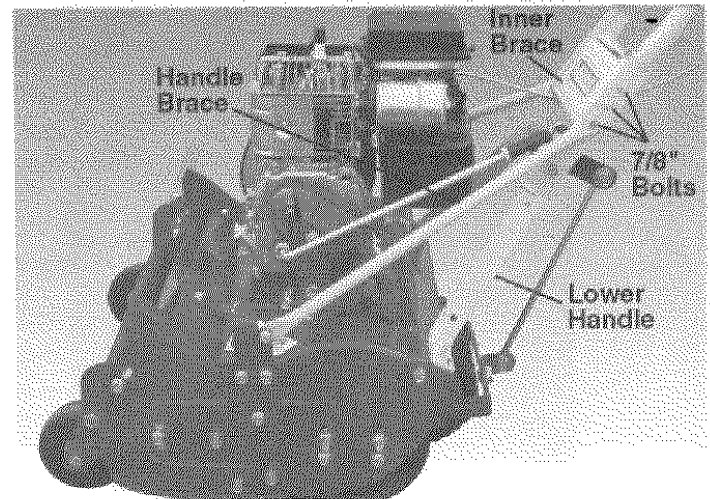

FIGURE 2: Tighten all six handle bolts and nuts **SECURELY**.

- F. Install the three handle grips (included in the hardware kit) on the upper handles and manual drive lever (see Figure 3). Soak the grips in hot water for a few minutes to aid in installation.

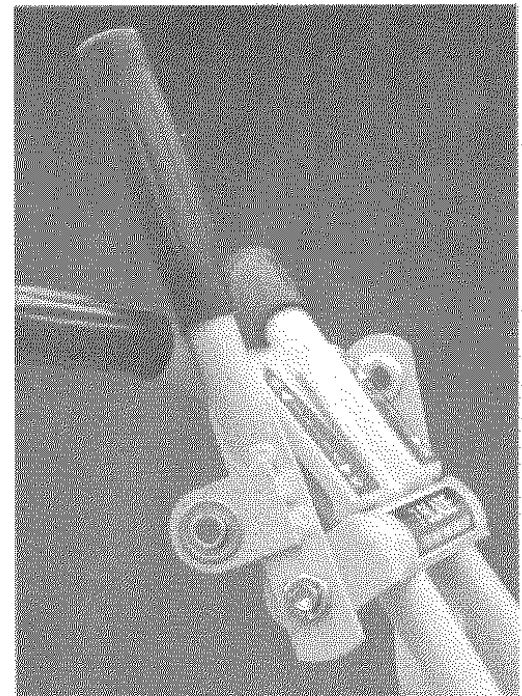

FIGURE 3: Soak the grips in hot water for a few minutes to aid in installation.

2. Install the drive control rod:

NOTE: The drive control rod is a long one-piece rod with a 90-degree bend at each end.

- A. Insert the lower end of the drive control rod through the hole in the drive pivot rod.
- B. Rotate the manual drive lever forward, and insert the upper end of the drive control rod through the manual drive lever bearing (see Figure 4 on page 6).
- C. Install a cotter pin (included in the hardware kit) through the hole in each end of the drive control rod, and bend in place to secure.

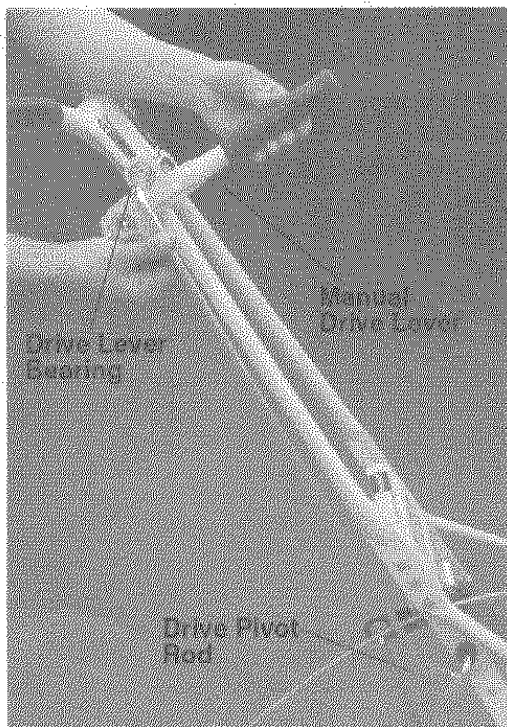

FIGURE 4: Insert the upper end of the drive control rod through the manual drive lever bearing, then secure with a cotter pin.

3. Install the throttle control lever in the upper handle:

NOTE: The carburetor connection of the throttle control cable is factory installed. The throttle control lever must be secured to the control panel in the upper handle.

- A. Route the throttle cable underneath and behind the handle assembly inner brace, and bring the throttle control lever up behind the cutout in the handle assembly control panel.
- B. Hold the control lever at the end of the throttle cable and twist it slightly so the knob can pass through the cutout in the upper handle control panel (see Figure 5).

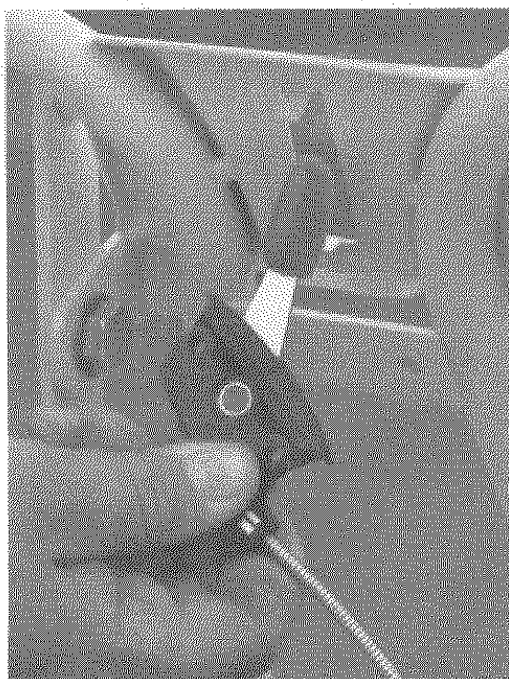

FIGURE 5: Twist the throttle control lever so the knob can pass through the cutout in the panel.

- C. When the knob is completely through the control panel, straighten the throttle cable so the throttle control body can be pushed completely through the cutout in the panel.
- D. Push the entire throttle control body from the back through the panel cutout.
- E. Align the throttle control body with the cutout in the control panel. Use both hands to press the throttle control body into the panel until it locks in place.

4. Install the upper clutch control rod:

NOTE: The clutch control rod assembly consists of an upper clutch control rod, lower clutch control rod, coupler and two lock nuts. The upper clutch control rod is threaded on one end (with a lock nut installed) and has a 90-degree bend at the opposite end. The lower clutch control rod, coupler and one lock nut are factory-installed.

- A. Thread the upper clutch control rod into the coupler by turning clockwise several times.
- B. Insert the upper end of the control rod through the clutch lever bearing (see Figure 6).

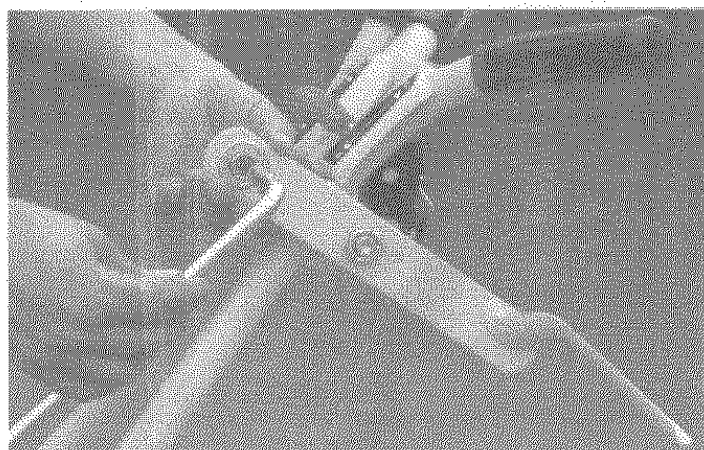

FIGURE 6: Insert the upper end of the control rod through the clutch lever bearing, then insert a cotter pin. **DO NOT** bend the cotter pin until clutch rod tension is adjusted.

- C. Insert a cotter pin (included in the hardware kit) through the hole in the upper end of the control rod. **DO NOT** bend the cotter pin or tighten the lock nut until the clutch rod tension is adjusted (see **ENGINE CLUTCH ROD ADJUSTMENT** for details).

CLUTCH CONTROL ROD ADJUSTMENT

IMPORTANT: Excessive tension will reduce the life of the clutch belt and will result in poor mower performance. Be sure clutch rod tension is adjusted properly.

With the clutch lever engaged (lifted until it contacts the handle), the clutch rod should apply a slight tension to the clutch belt (see Figure 7 on page 7). The tension should be just enough to propel the mower and reel while mowing, without stopping, and without the belt slipping on the pulley.

1. Check for proper clutch rod tension:

WARNING: Disconnect the spark plug wire from the spark plug. **Keep the spark plug wire away from the spark plug** to prevent accidental starting. Keep clear of the reel while checking clutch rod tension.

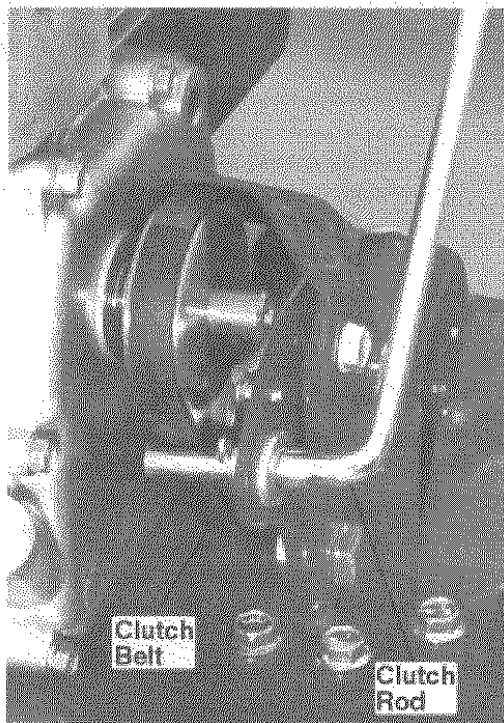

FIGURE 7: When clutch rod tension is properly adjusted, the clutch rod should apply a slight tension to the clutch belt.

- A. Engage the clutch by lifting the clutch lever until it contacts the handle, then pull the rope starter and observe the mower reel.
- B. If the reel turns, the clutch rod tension should be correct. However, make sure the clutch rod is not putting excessive tension on the clutch belt.
- C. If the reel does not turn, the clutch rod must be adjusted to provide more tension.

2. Adjust the clutch rod tension as needed:

- A. Remove the cotter pin from the upper clutch control rod.
- B. To **increase** clutch rod tension, remove the upper clutch control rod from the clutch lever, then turn the clutch control rod counterclockwise one full turn (into the coupler). Insert the upper end of the control rod through the clutch lever bearing, and re-check clutch rod tension as described in step 1. Repeat until the correct clutch rod tension is obtained.

- C. To **decrease** clutch rod tension, remove the upper clutch control rod from the clutch lever, then turn the clutch control rod clockwise one full turn (out of the coupler). Insert the upper end of the control rod through the clutch lever bearing, and re-check clutch rod tension as described in step 1. Repeat until the correct clutch rod tension is obtained.
- D. When the correct clutch rod tension is obtained, install the cotter pin (removed in step A, above) through the hole in the upper clutch control rod, and bend in place to secure. Tighten both lock nuts until they are seated firmly against the coupler.
- E. Reinstall the spark plug wire on the spark plug.

GRASS CATCHER INSTALLATION

1. Refer to Figure 8. Loosen the rear nuts and bolts on the catcher hooks. Remove the front nut and bolt from each catcher hook, then rotate the catcher hooks into the correct position and fasten each hook with the two bolts and nuts. Do not fully tighten the nuts until the grass catcher is adjusted for proper clearance from the reel blades.

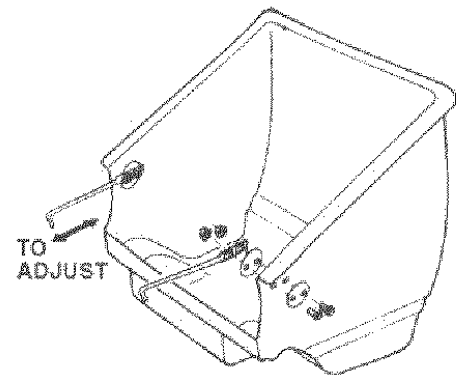

FIGURE 8: Adjust the grass catcher for proper clearance from the reel blades before tightening the catcher hook nuts.

2. Attach the grass catcher to the mower and make sure the catcher does not touch the reel blades. The catcher hooks are slotted so you can easily adjust the catcher so it will clear the reel blades.
3. When proper clearance is obtained, tighten the nuts and bolts holding the catcher hooks to the grass catcher.

OPERATION

FUEL AND OIL

NOTE: Refer to the engine manual (provided separately) for proper procedures to fill the engine crankcase and fuel tank.

Engine Oil Recommendations

The mower is shipped WITHOUT oil. Only use high quality detergent oil rated with API service classification SF or SG. Select the oil's SAE viscosity grade according to your expected operating temperature. For most geographic locations (for operation at 32°F or higher, 30 wt or 10W-30 wt. oil is recommended.

Although multi-viscosity oils (5W-30 wt, 10W-30 wt, etc.) improve starting in cold weather, these oils will result in

increased oil consumption when used at temperatures above 32°F. Check your engine oil level more frequently to avoid possible engine damage from running low on oil. **Do not** use 10Wt-40Wt oil.

Fuel Recommendations

WARNING: Fuel is HIGHLY flammable. Handle with care. Use only approved fuel containers. Never add fuel while the engine is running. Fill the fuel tank outdoors only. NEVER fill the fuel tank indoors. Replace the fuel tank cap securely, and clean up all spilled fuel.

Clean, fresh **lead-free** gasoline is recommended for use with the mower. Leaded gasoline may be used if lead-free is not available. A minimum of 77 octane is recommended. The use of lead-free gasoline results in fewer combustion deposits and longer valve life.

NOTE: We **DO NOT** recommend the use of gasoline that contains alcohol, such as gasohol. However, if gasoline with alcohol is used, it **MUST NOT** contain more than 10 percent Ethanol and **MUST** be removed from the engine during storage. **DO NOT** use gasoline containing Methanol.

CAUTION: Experience indicates that alcohol blended fuels (such as gasohol, or fuels containing ethanol or methanol) can attract moisture, which leads to separation and formation of acids during storage. Acidic gas can damage the fuel system of an engine while in storage.

To avoid engine problems, the fuel system should be emptied whenever placing the mower in storage for 30 days or longer. Drain the gas tank, start the engine and let it run until the fuel lines and carburetor are empty. Use fresh fuel next season. See **STORAGE** Instructions for additional information.

Never use engine or carburetor cleaner products in the fuel tank or permanent damage may occur.

CUTTING HEIGHT ADJUSTMENT

The mower cutting height is adjustable from 1/4" x 1-1/2". Cutting height is determined by the mounted position of the front wheel assembly and the setting selected by the cutting height adjustment lever. Additionally, the 1-1/2" cutting height requires adjustment of the rear axle (see **REAR AXLE ADJUSTMENT** for details).

Three holes in the mower side panels (see Figure 9) allow the position of the front wheel assembly bar to be changed to obtain the desired cutting height range.

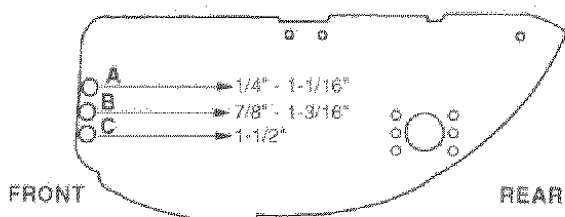

FIGURE 9: Use the front wheel assembly cutting height adjustment holes and height adjustment lever to set the cutting height of the mower.

Once the desired cutting range is set, the cutting height adjustment lever (see Figure 10) is placed in one of four preset positions (notch 1 through notch 4) to select the desired cutting height (see Table 1).

NOTE: When changing the position of the front wheel assembly, the "pivot point" locations of the cutting height adjustment lever must also be changed. When using adjustment hole "A" or "B" hole in the side panel (see Figure 9) for the front wheel assembly position, the "pivot point" locations for the cutting height adjustment lever (see Figure 10) must also be changed to the "A" or "B" positions, as appropriate. When using adjustment hole "C" in the side panel, the cutting height adjustment lever "pivot point" locations should be placed in position "B".

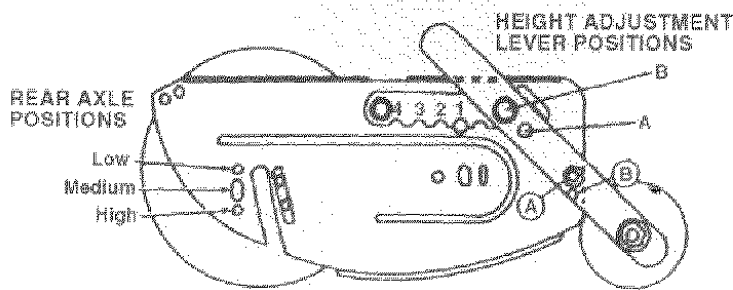

FIGURE 10: Rear axle positions; height adjustment lever positions

Cutting height adjustment holes "A" and "B" are used for all height adjustments EXCEPT for the 1-1/2" height. Adjustment hole "C" is used for the 1-1/2" adjustment ONLY.

TABLE 1. Available cutting heights

LEVER POSITION	HEIGHT		
	A	B	C
Notch No. 1	1/4"	7/8"	-
Notch No. 2	7/16"	1"	-
Notch No. 3	5/8"	1-1/8"	-
Notch No. 4	1-1/16"	1-3/16"	-
Notch No. 4	-	-	1-1/2"

REAR AXLE ADJUSTMENT

The mower is shipped with rear axle in the middle (medium) position, and the cutting heights listed in Table 1 are achieved with the axle in this position. The rear axle must be lowered to the high position (see Figure 10) to obtain the 1-1/2" cutting height.

NOTE: The rear axle height positions may be changed by the mower owner; however, due to the mechanics involved it is recommended the procedure be done by an Authorized McLane Service Center.

To adjust the rear axle position (Figure 11):

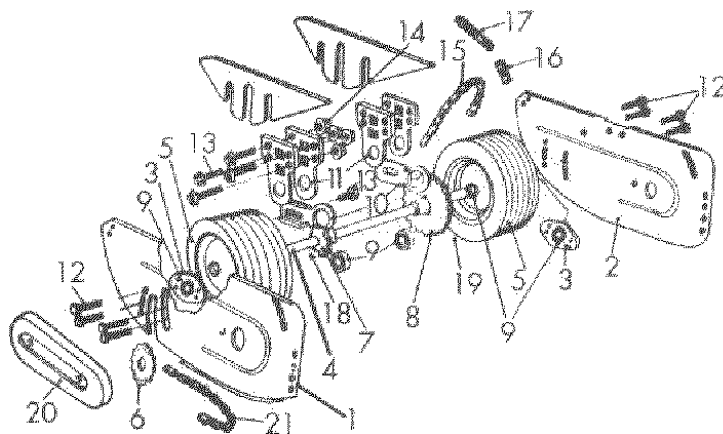

FIGURE 11: Rear axle adjustment

1. Drain the gas and oil from the engine. Position the mower so the front wheels and the engine are resting on the ground or other suitable work surface.
2. Remove chain guard (20).

3. Remove sideplate chain (21), and modify as follows:
 - A. Remove clutch drive chain (15) and add two PN 5016 chain links to the chain.

NOTE: Chain links can be purchased from the factory or from an authorized McLane Service Center.
4. Remove eight retainer bolts (12). Loosen eight hanger bolts (13).
5. Move the rear axle outward until the retainer bolt hole aligns with the high hole in the sideplate (see Figure 10).
6. Replace and tighten eight retainer bolts (12). Tighten eight hanger bolts (13).
7. Replace sideplate chain (21) and clutch drive chain (15).
8. Refill oil and gasoline.

OPERATING CONTROLS (FIGURE 12)

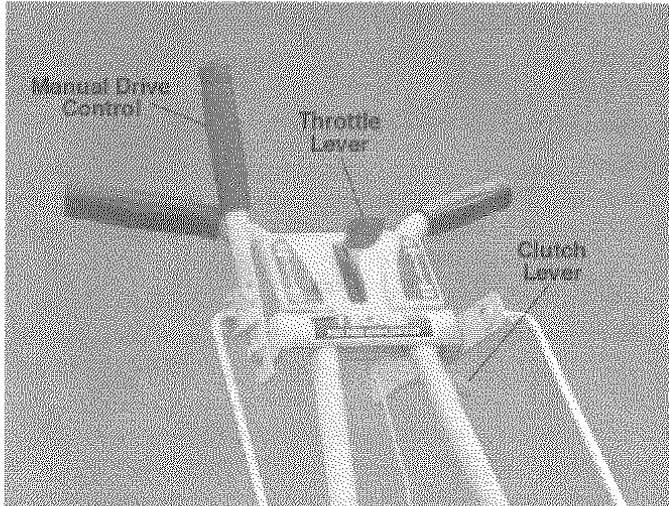

FIGURE 12: Operating controls

■ Throttle Lever

The Throttle Lever is located in the center of the handle assembly control panel. The Throttle Lever is used to control engine speed during operation, and also controls starting and stopping of the engine.

■ Clutch Lever

The Clutch Lever is located on the left side of the handle assembly. When raised, the Clutch Lever engages the clutch, which drives the mower reel. For personal safety, the reel and mower stop immediately when the Clutch Lever is released.

■ Manual Drive Lever

The Manual Drive Lever is located on the right side of the handle assembly. After the Clutch Lever is engaged, pushing the Manual Drive Lever forward causes the drive wheel to engage the ground and drive the mower.

OPERATING THE MOWER

WARNING: Carbon monoxide is generated as a byproduct of operating an internal combustion engine, such as that used on this mower. Carbon monoxide is a dangerous gas that can cause unconsciousness and is potentially lethal. Carbon monoxide gas is colorless and odorless. Take care to avoid inhaling exhaust gases while using the mower. Do not run the engine in a confined area such as a closed garage.

WARNING: Operation of any lawn mower can result in foreign objects thrown into the eyes, which can result in severe eye damage. Always wear safety glasses or eye shields before starting your lawn mower and while mowing. We recommend Wide Vision Safety Mask for over the spectacles or standard safety glasses.

CAUTION: Before starting engine, become familiar with all controls. Read this Operator's Manual thoroughly. Always check engine oil level before starting engine.

Starting the Mower

NOTE: This paragraph provides "general" instructions for starting the mower. Before starting the mower, refer to the engine manual (provided separately) for detailed engine manufacturer's instructions.

1. Move the mower throttle control lever forward (out of the STOP position).
2. **For choke-equipped engines:** Move the choke control lever (located on the engine) to the CHOKÉ position.
3. Grasp and pull the rewind starter handle slowly until you feel resistance, then pull rapidly. Repeat as necessary until the mower engine starts to run. Allow the engine to warm up.
4. **For choke-equipped engines:** Slowly move the choke control lever (located on the engine) toward the RUN position. Pause between adjustments until the engine runs smoothly.
5. Adjust the position of the mower throttle control lever as needed to increase or decrease engine speed.
6. Lift the clutch lever and hold against the handle grip to engage the reel clutch; the reel will begin to rotate.
7. Move manual drive lever to forward (down) to engage the mower drive; the mower will begin to move forward.
8. To disengage the reel drive, immediately release the clutch lever.
9. To stop the engine, move throttle lever back to the STOP position.

Stopping the Mower

1. Release the clutch lever to stop the self-propel mechanism and cutting reel.
2. Move the throttle control lever back to the STOP position to stop the engine.

MAINTENANCE AND SERVICING

GENERAL RECOMMENDATIONS

WARNING: Disconnect the spark plug wire from the spark plug **BEFORE** performing any maintenance or servicing procedure. Keep the spark plug wire away from the spark plug to prevent accidental starting.

1. Replace the spark plug and air filter once a year. This will assure better engine performance and longer engine life.
2. Check all fasteners frequently for security; tighten as needed.
3. Refer to Table 2, Service recommendations and service record, for suggested scheduled maintenance requirements. Spaces are provided to make note of the dates on which service procedures were performed.

NOTE: Refer to the engine manual (provided separately) for detailed procedures for changing engine oil, servicing the air cleaner, and servicing the spark plug.

CLEANING THE COOLING SYSTEM

Grass, chaff or dirt may clog the rotating screen and the air cooling system, especially after prolonged service cutting dry grass. Yearly, or every 100 hours, whichever occurs first, remove the blower housing and clean the areas to avoid overspeeding, overheating and engine damage. Clean more often if necessary. Refer to the engine manual (provided separately) for detailed instructions.

CLEANING THE ENGINE

Remove dirt and debris with a cloth or brush. Cleaning with a forceful spray of water is not recommended, as water could contaminate the fuel.

LUBRICATION

Check oil level regularly. Oil all exposed bearings, linkage and front wheels. Oil chain frequently. The reel and main drive bearings are sealed, and do not require lubrication.

REEL MAINTENANCE

Normally grinding of the wheel is not recommended or necessary to insure proper cutting. This is due to the extreme hardness and great strength of the reel. Sharpening and back lapping when required, should always be done by a properly equipped service center.

CLUTCH BELT MAINTENANCE

Inspect the clutch belt frequently for damage or excessive wear. Worn or damaged belts can cause the clutch to operate improperly, and may result in continuous movement of the reel and self propel mechanism when all levers are disengaged. Replace the belt when excessive wear or damage occurs.

Clutch Belt Replacement

Refer to the Front Throw Reel Mower Repair Parts illustration on page 12.

1. Remove cotter pin (11) from lower clutch control rod (12), and slide control rod from clutch rod bearing (46).
2. Remove belt guard bolt (59) using 1/2" wrench and remove belt guard (61) from the clutch body (45).
3. Detach deadman clutch spring (52) from deadman belt idler arm (47).
4. Remove the worn belt (60).
5. Install new belt (60) by placing around jack shaft pulley (53) first, and then around the engine pulley (63). Make sure the idler bearing (48) rests against the inside of the belt (60). (The belt must be placed over the pulleys and the idler bearing).
6. Replace deadman clutch spring (52) (attach to belt idler).
7. Replace belt guard (61) and belt guard bolt (59). Do not tighten belt guard bolt (59) until belt guard has been adjusted (step 12).
8. Replace clutch control rod (12), making sure rod is placed outside of the belt.
9. Replace cotter pin (11) and check clutch control rod for proper tension (refer to **CLUTCH CONTROL ROD ADJUSTMENT** on page 6 for procedure).
10. Check the clutch belt guard (61) for proper adjustment:
 - A. Engage the clutch by lifting the clutch lever until it contacts the handle.
 - B. Verify there is a 1/16" clearance between the top of the clutch belt (60) and the bottom of the clutch belt guard (61). Adjust the clutch belt guard up or down to obtain the required 1/16" clearance.
11. When the 1/16" clearance is obtained, tighten clutch belt guard bolt (59) firmly.

IMPORTANT: Improper adjustment of the belt guard and tension of the clutch control rod can cause premature wear of the clutch belt, and failure of proper clutch action.

Table 2. Service recommendations and service record

Service Requirements	Frequency					Enter date when service is completed
	Every 5 Hrs	Every 25 Hrs	Every 50 Hrs	Every Season (100 Hrs)	Each Use	
Change Engine Oil	X		X			
Check Engine Oil Level					X	
Service Air Cleaner		X				
Clean/Replace Spark Plug				X		
Lubricate Mower			X			
Check Muffler				X		
Clean Mower					X	

TROUBLESHOOTING

PROBLEM	CAUSE / REMEDY
1. Engine fails to start.	<p>A Check fuel tank for gas.</p> <p>B Spark plug lead wire disconnected.</p> <p>C Throttle control lever not in starting position.</p> <p>D Check spark plug.</p> <p>E Carburetor improperly adjusted. Engine flooded. Remove spark plug, dry the plug, crank engine with plug removed, and throttle in off position. Replace spark plug and lead wire and resume starting procedures.</p> <p>F Old/stale gas. Drain and refill with fresh gas.</p>
2. Hard starting or loss of power.	<p>A Spark plug wire loose.</p> <p>B Carburetor improperly adjusted.</p> <p>C Dirty air cleaner.</p>
3. Operation erratic.	<p>A Dirt in gas tank. Drain, clean and refill.</p> <p>B Dirty air cleaner.</p> <p>C Water in fuel supply. Drain and refill.</p> <p>D Vent in gas cap and/or carburetor plugged. Clear vent.</p> <p>E Carburetor improperly adjusted.</p>
4. Occasional skip (hesitates) at high speed.	<p>A Spark plug fouled, faulty or gap too wide.</p> <p>B Carburetor improperly adjusted.</p> <p>C Dirty air cleaner.</p>
5. Engine idles poorly.	<p>A Carburetor idle speed too slow.</p> <p>B Spark plug gap too close.</p> <p>C Carburetor idle mixture adjustment improperly set.</p>
6. Engine overheats.	<p>A Adjust carburetor.</p> <p>B Remove any obstructions from air passages in shrouds.</p> <p>C Clean cooling fins.</p> <p>D Fill crankcase to proper oil level.</p>

STORAGE

MOWER

- A.** Clean all debris off mower and engine with a rag or brush. Do not use water.
- B.** Oil all chains and wipe off excess oil with a rag.

ENGINE

Engines to be stored over 30 days should be completely drained of fuel to prevent gum deposits forming on essential carburetor parts, fuel filter and tank.

NOTE: The use of a fuel additive, such as STA-BIL®, or an equivalent, will minimize the formation of fuel gum deposits during storage. Such an additive may be added to the gasoline in the fuel tank of the engine, or to the gasoline in a storage container.

- A.** Remove all fuel from the fuel tank. Run the engine until it stops from lack of fuel.
- B.** While engine is still warm, drain oil from crankcase. Refill with fresh oil.
- C.** Remove spark plug, pour approximately 1/2 ounce (15 cc) of engine oil into cylinder and crank slowly to distribute oil. Replace spark plug.

D. Clean dirt and chaff from cylinder, cylinder head fins, blower housing, rotating screen and muffler areas.

E. Store in a clean and dry area.

IMPORTANT: It is important to prevent gum deposits from forming in essential fuel system parts such as the carburetor, fuel filter, fuel hose, or tank during storage. Also, experience indicates that alcohol blended fuels (called gasohol or using ethanol or methanol) can attract moisture which leads to separation and formation of acids during storage. Acidic gas can damage the fuel system of an engine while in storage.

OTHER

Do not store gasoline from one season to another.

- A.** Replace your gasoline can if your can starts to rust. Rust and/or dirt in your gasoline can cause problems.
- B.** Do not store your mower under any plastic cover. Plastic cannot breathe, which allows condensation to form and can cause your mower to rust.

ASSEMBLY AND ADJUSTMENT

TOOLS REQUIRED

Pliers, Screwdriver, 7/16" Wrench, (11/16" Wrench needed to adjust Clutch Tension)

UNPACKING

The lawn mower is shipped fully assembled except for the handle, throttle control, drive control rod and clutch control rod. All items are packed and shipped in one container.

1. Open the carton.
2. Remove the grass catcher, handle assembly, drive control rod and upper clutch control rod.
3. Remove the cardboard packing material from the carton.
4. Cut the back panel of the carton, and fold down flat.
5. Roll the mower out of the carton.
6. Disconnect the spark plug wire from the spark plug, remove the hardware kit, then reconnect the spark plug wire to the spark plug.

ASSEMBLY

NOTE: Reference to left or right side of the mower is made from the user's position at the handle, facing forward.

1. Install the handle assembly:

NOTE: Six bolts and nuts are used to secure the handle assembly; two bolts and nuts are factory-installed, the remaining bolts and nuts are included in the hardware kit.

- A. Remove the bolt and nut securing the left-side handle brace to the lower handle and inner brace (see Figure 1).

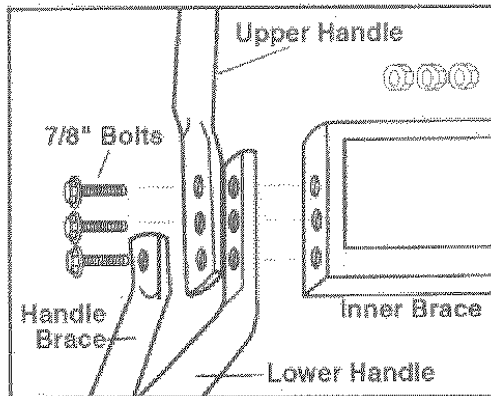

FIGURE 1: Use two factory-installed bolts and nuts, plus four bolts and nuts included in the hardware kit to install the handle.

- B. Position the upper handle between the handle brace and lower handle, aligning the three holes in the upper handle with the three holes in the lower handle. Reinstall the bolt removed in step A through the handle brace, upper handle, lower handle and inner brace. Reinstall the nut **FIN-GER TIGHT ONLY**.
- C. Repeat steps A and B for the right-side of the handle.
- D. Adjust the position of the upper handle as needed to align the holes in the upper handle with the holes in the lower handle, then install the remaining four bolts through the upper handle, lower handle and inner brace.

- E. Install one nut on each bolt, then tighten the nuts **SECURELY** (see Figure 2).

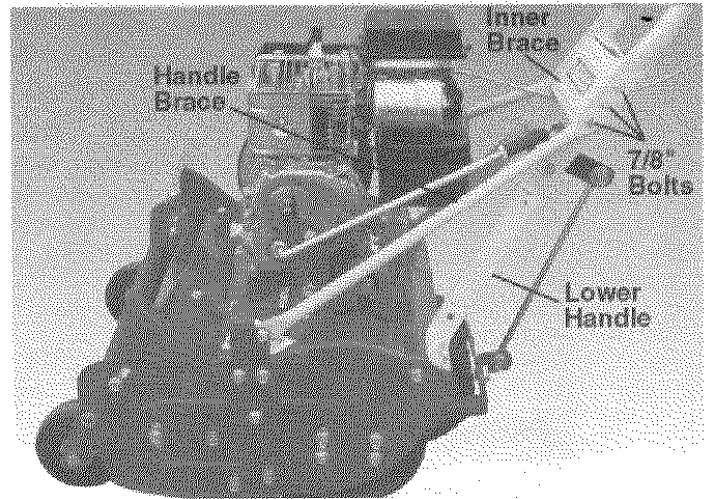

FIGURE 2: Tighten all six handle bolts and nuts **SECURELY**.

- F. Install the three handle grips (included in the hardware kit) on the upper handles and manual drive lever (see Figure 3). Soak the grips in hot water for a few minutes to aid in installation.

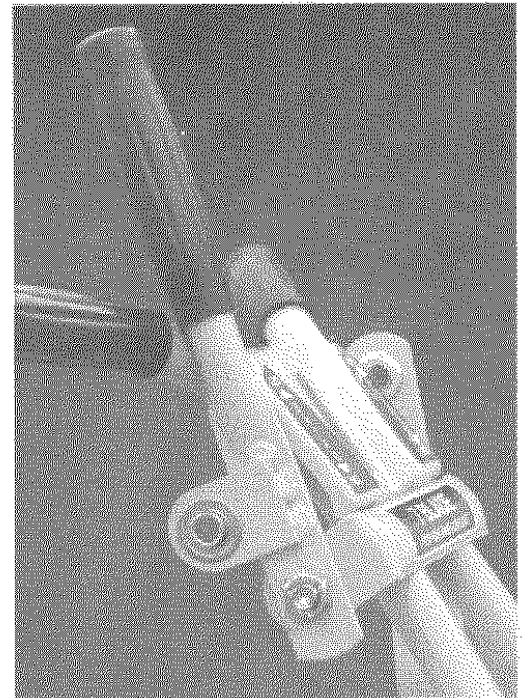

FIGURE 3: Soak the grips in hot water for a few minutes to aid in installation.

2. Install the drive control rod:

NOTE: The drive control rod is a long one-piece rod with a 90-degree bend at each end.

- A. Insert the lower end of the drive control rod through the hole in the drive pivot rod.
- B. Rotate the manual drive lever forward, and insert the upper end of the drive control rod through the manual drive lever bearing (see Figure 4 on page 6).
- C. Install a cotter pin (included in the hardware kit) through the hole in each end of the drive control rod, and bend in place to secure.

REF. NO.	PART NO.	DESCRIPTION	USED ON	REF. NO.	PART NO.	DESCRIPTION	USED ON
1	1001-A	Handle	20"	59	1033	*5/16" - 18 x 1/2" Bolts	ALL
	4001-A	Handle w/Shoulder Bolts	25"	60	1060-B	Clutch Belt	20"
2	7015-A	Shoulder Bolt for Handle	ALL		1060	Clutch Belt	25"
3	1003	Handle Grips (2 req.)	ALL	61	1061	Belt Guard	ALL
4	1004	Drive Control Lever	ALL	62	1062	*5/16" - 18 x 3/8" Bolts	-ALL
5	1005-D	Clutch Control Lever	ALL	63	1063	Engine Pulley	20"
7	1007	Plastic Washer (2 req.) L & R	ALL		4063	Engine Pulley	25"
8	1008	*Lock Nuts 7/16" - 14 (2req.) L & R	ALL	64	1064	*Key For Engine Pulley Shaft 3/16"x3/16"x5/8"	ALL
9	1009	Drive & Clutch Lever Grips	ALL	65	1065	Allen Set Screw 5/16" - 24 x 15/16"	ALL
10	1010	Drive Control Rod	ALL	66	1066-D	Rear Axle shaft	ALL
11	1011	*Cotter Pins 1/8" x 1/2" (3 req.)	ALL	67	1067-D	Retainer	ALL
12	1012-D	Clutch Control Rod	ALL	68	1068	Sprocket (30 teeth with Hub)	ALL
13	1013-97	Throttle Control-Manual Choke	20"	69	1069	Sprocket (8 teeth with Hub)	ALL
	4013	Throttle Control Assembly	25"	70	1070	*Set Screws 7/16" - 20 x 7/16" Half Dog (3 req.)	ALL
14	1014	Handle Brace Plate	20"	71	1071	Axle Support Bearing (2 req.)	ALL
	4014	Handle Brace Plate	25"	72	1072	Roller Bracket Supports (2 req.)	ALL
15	1015	*1/4 - 28 Nuts (6 req.)	ALL	73	1073	Axle hangers (4 req.)	ALL
16	1016	Lower Handle (2 req.)	ALL	74	1074	*Hanger Bolts 5/16" - 24 x 7/8" (8 req.)	ALL
18	1018	*1/4 - 28 x 7/8" Bolts (6 req.)	ALL	75	1075	*5/16" - 24 Nuts (8 req.)	ALL
19	1019	Handle Brace (2 req.) L & R	20"	76	1076-P	Spacer	ALL
	4019	Handle Brace (2 req.) L & R	25"	77	1077-P	Spacer	ALL
20	1020	*1/4 - 28 x 5/8" Bolts (2 req.) L & R	ALL	78	1078-S	Rear Wheels w/Bearings (2 req.)	ALL
21	1015	*1/4" - 28 Nuts (2 req.) L & R	ALL		6058	Bearing For 1078-S	ALL
22	1022	Drive Pivot Rod	20"	79	1037-D	Retainer Bearing	ALL
	4022	Drive Pivot Rod	25"	80	1080	*Roller Drive Chain No. 41-36 Pitch	ALL
23	1023	Drive Pivot Spring	20"	81	1057	*Connecting Link No. 41	ALL
	4023	Drive Pivot Spring	25"	82	5001	Slide Plate w/Chain Guard Bracket	ALL
24	1024	Drive Pivot Arm	ALL	83	1083	Catcher Hook Bracket	ALL
25	1025	*Set Screw 3/8" - 16 x 1/2" Square Head	ALL	84	1028	*5/16" - 18 x 3/4" bolts (4 req.)	ALL
26	1026	Lower Drive Control Rod	ALL	85	5002	Side Plate	ALL
27	1011	*Cotter Pin 1/8" x 1/2"	ALL	86	1086	Catcher Hook Bracket	ALL
28	1028	*5/16 - 18 x 3/4" Bolts (4 req.) L & R	ALL	87	1028	*5/16 - 18 x 3/4" Bolts (4 req.)	ALL
29	1029	Deck	20"	88	1088	Sprocket (17 teeth)	ALL
	4029	Deck	25"	89	1070	*Set Screws 7/16" - 20 x 7/16" Half Dog (4 req.)	ALL
30	1030	Handle Brackets (2 req.)	ALL	90	1033	*5/16" - 18 x 1/2" Bolts (2 req.)	ALL
31	1031	Roller Support Bracket with Bearing	20"	91	1091-A	Sprocket (13 teeth)	ALL
	4031	Roller Support Bracket with Bearing	25"	92	1092	*Reel Drive Chain No. 41-46 Pitch	ALL
32	1032	Roller Support Bracket	20"	93	1057	*Connecting Link No. 41	ALL
	4032	Roller Support Bracket	25"	94	1094	Chain Guard	ALL
33	1033	*5/16 - 18 x 1/2" Bolts (2 req.)	ALL	95	1033	*5/16 - 18 x 1/2" Bolts (2 req.)	ALL
34	1034	Roller Drive Tube	20"	96	1096	Height Adjustment Lever	ALL
	4034	Roller Drive Tube	25"	97	1097	Height Adjustment Notched Bracket	ALL
35	1035	Roller Drive Tires (5 req.)	20"	98	7050	*5/16 - 18 x 3/4" Bolt	ALL
	4035	Roller Drive Tires (6 req.)	25"	98A	1075-A	5/16" - 18 Nut	ALL
36	1036	Roller End Caps (2 req.)	ALL	99	1099	Spacer Bushing	ALL
37	1037	Ind Cap Bearings (2 req.)	ALL	100	1100	Height Adjustment Spring	ALL
38	1038	Roller Drive Sprocket (30 teeth)	ALL	101	1101-2	Shield	20"
39	1039	Roller Drive Bolts (3 req.)	20"		1101-A	Shield Assembly Hardware	20"
	4039	Roller Drive Bolts (3 req.)	25"		4101-2	Shield	25"
40	1015	*1/4" - 28 Drive Nuts (6 req.)	ALL		4101-A	Assembly Hardware	25"
41	1041	Roller Drive Shaft	20"	102	1033	*5/16 - 18 x 1/2" Bolt (2 req.)	ALL
	4041	Roller Drive Shaft	25"	103	1103-A	Bed Knife	20"
42	1042	Spacer	20"		4103-A	Bed Knife	25"
	4042	Spacer	25"	104	1028	*5/16 - 18 x 3/4" Bolts (2 req.)	ALL
43	1043-A	Engine, State Model	ALL	105	1105	Tapered Bolts 5/16" - 18 x 5/8" (6 req.)	ALL
44	1044	*5/16 - 24 x 1-1/2" Bolts (4 req.)	ALL	106	1106	Bushing for Tapered Bolt (6 req.)	ALL
45	1045-D	Main Clutch Body	ALL	107	1107	Reel Assembly 7 Blade	20"
46	1046-D	Clutch Rod Bearing	ALL		4107	Reel Assembly 7-Blade	25"
47	1047-D	Belt Idler Arm	ALL	108	1108	Reel Bearings (2 req.)	ALL
48	1048-D	Idler Bearing	ALL	109	1109	Reel Bearing Retainer	ALL
49	1049	*3/8 - 16 1/2" Flat Head Phillips Head Screw	ALL	110	1033	*5/16 - 18 x 1/2" Bolts (2 req.)	ALL
50	7015-A	Bolt for Clutch Body	ALL	111	1111	Reel Bearing Retainer	ALL
51	1051	Washer	ALL	112	1112	Front Wheel Assembly Bar	20"
52	1052-D	Clutch Spring w/Spring Plate	ALL		4112	Front Wheel Assembly Bar	25"
53	1053	Jack Shaft with Pulley & Sprocket	20"	113	1113	Tie rod	20"
	4053-A	Jack Shaft with Pulley & Sprocket	25"		4113	Tie Rod	25"
54	1054	Jack Shaft Housing (2 req.)	ALL	114	1007	Plastic Washer	ALL
55	1028	*5/16" - 18 x 3/4" Bolts (4 req.)	ALL	115	1008	*7/16" - 14 Nuts (2 req.)	ALL
56	1092	Clutch Drive Chain - No. 41 x 46 Pitch	ALL	115A	1008-A	*7/16" - 14 Jam Nuts (2 req.)	ALL
57	1057	*Connecting Link for No. 41 Chain	ALL	116	1116	Front Wheels with Bearings	ALL
58	1058	Clutch Chain Guard	ALL	117	1002	Front Wheel Bearings (2 req.)	ALL

REF. PART NO.	PART NO.	DESCRIPTION	USED ON	REF. PART NO.	PART NO.	DESCRIPTION	USED ON
118	1118	*7/16" - 14 x 3-1/2" Bolt	20"	122	4122	Grass Catcher	25"
118	4118	7/16"-14 x 6" Bolt	25"	124	1124	Catcher Hook	ALL
119	1008	*7/16" - 14 Nuts (2 req.)	ALL	125	3065	Washer	ALL
120	1120	Flat Washer	ALL	127	1127	Catcher Hook	ALL
121	1121	*7/16" - 14 x 3-1/4" Bolt	20"	128	1028	1/4" - 28 x 7/8" Bolt (4 req.)	ALL
121	4121	7/16"-14 x 5-1/4" Bolt	25"	N/S	3122**	Owner's Handbook - Repair Parts	ALL
122	1122	Plastic Grass-Catcher	20"	N/S	1202E**	Engine Operating Instruction Manual	ALL

* Standard Hardware items, may be purchased locally.

** NOT SHOWN

FRONT THROW REEL MOWER PARTS

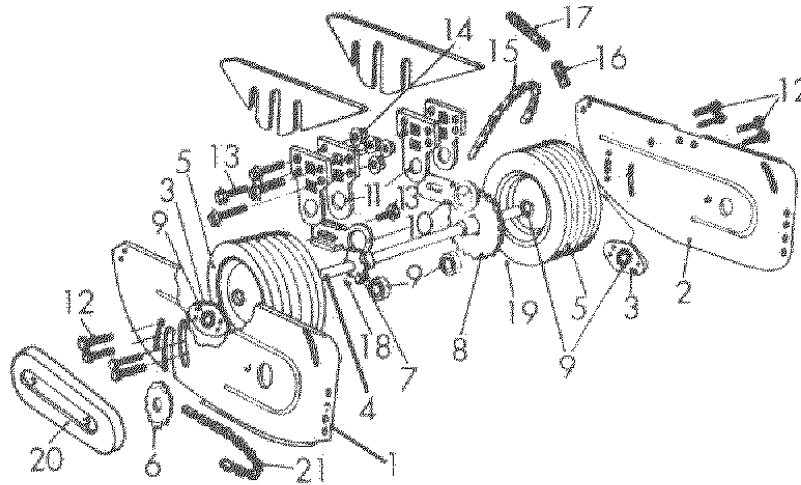

REF. PART NO.	PART NO.	DESCRIPTION	USED ON	REF. PART NO.	PART NO.	DESCRIPTION	USED ON
1	5001	Sideplate (Right)	ALL	11	5011	Axle Hangers	ALL
2	5002	Sideplate (Left)	ALL	12	1033	5/16"-18x1/2" Bolt	ALL
3	5003	Sideplate Bearing Retainer	ALL	13	1074	5/16"-24x7/8" Bolt	ALL
4	5004	Rear Axle	20"	14	1075	5/16"-24 Nut	ALL
	5004-B	Rear Axle	25"	15	1056	Clutch Drive Chain-44 Pitch	ALL
5	5005	Rear Wheels w/Bearings-ea	20"	16	5016	2-Link #41 Chain w/Master Link	ALL
	5005-A	Rear Wheels w/Bearings-ea	25"	17	5017	4-Link #41 Chain w/Master Link	ALL
6	5006	Sprocket (17 Teeth)	ALL	18	5018	Spacer Right	20"
7	5007	Sprocket (8 Teeth)	ALL		5018-B	Spacer Right	25"
8	5008	Sprocket (30 Teeth)-20"	20"	19	5019	Spacer Left	20"
	5008-B	Sprocket (30 Teeth)-25"	25"		5019-B	Spacer Left	25"
9	1008	Sealed Bearing (8 Req)	ALL	20	1094	Chain Guard	ALL
10	5010	Roller Bearing Supports	ALL	21	1092	Sideplate Chain	ALL

MCLANE MANUFACTURING INC.
7110 East Rosecrans Ave., Paramount CA 90723
Telephone (562) 633-8158 636-8336
