



## OPERATION GUIDE

For customer service on this appliance:

Phone: 1300 371 858

Web: [luxline.com.au](http://luxline.com.au) / [luxline.co.nz](http://luxline.co.nz)



GasMark

GMK10191

Thank you for choosing a Luxline Portable 8 hot water system. This manual contains information to help you get years of safe and enjoyable service from your gas hot water system. Please take the time to read it in full before operating.

**IMPORTANT!**

Read these instructions for use carefully. Familiarise yourself with the appliance before connecting it to its gas container. Keep these instructions for future reference.

**IMPORTANT!**

This appliance is designed to be used with a source water temperature of 20°C or below. If the temperature of the outlet water exceeds 50°C the burners will shut off. You will need to turn the water flow off and on again to reignite the burners.

**THIS APPLIANCE IS NOT INTENDED FOR THE SUPPLY OF DRINKING WATER.**

**THIS APPLIANCE IS INTENDED FOR THE SUPPLY OF HEATED WATER FOR THE PURPOSES OF WASHING AND CLEANING ONLY.**

**CHECK AND CONFIRM SAFE WATER TEMPERATURE BEFORE USING THIS APPLIANCE. WATER FROM THIS APPLIANCE MAY BE VERY HOT.**

**THIS APPLIANCE MUST BE PROTECTED FROM RAIN.**

## GENERAL WARNINGS

**This appliance shall only be used with a propane gas refillable container certified to AS2469. It may be hazardous to attempt to fit other types of gas containers.**

**This appliance shall only be used with a propane gas refillable container certified to AS2469. It may be hazardous to attempt to fit other types of gas containers.**

**This appliance shall only be used with the approved 1200mm propane gas hose and regulator assembly that have been supplied.**

**This appliance is to be stored in a dry and well-ventilated location away from direct sunlight. Do not store when still connected to the cylinder.**

**Make sure that the cylinder is disconnected and is stored in a well-ventilated area, out of reach of children, and free from direct sunlight, heat and ignition sources. If being stored indoors, ensure that the location complies with AS/NZS1596.**

**This appliance must only be serviced by an authorised person. It must be returned to its place of purchase for services and repairs.**

## DANGER!

- Use outdoors only.
- Only use in well ventilated areas.
- Caution: Accessible parts may be very hot. Keep young children away.
- Do not use this appliance if it is leaking, damaged, or not operating properly.
- Do not use this appliance if it has damaged or worn seals.
- This appliance shall only be used in an above ground open-air situation with natural ventilation, without stagnant areas, where gas leakage and products of combustion are rapidly dispersed by wind and natural convection.
- Only use the hose assembly as supplied with this appliance for connection to the cylinder. **DO NOT USE ADAPTORS.**
- Children must be supervised by an adult at all times when using this appliance.
- Never leave appliance unattended when operating.
- Do not use as a cooking appliance or modify for any other reason.

## CARBON MONOXIDE HAZARD

**USING THIS APPLIANCE IN AN ENCLOSED SPACE MAY CAUSE DEATH. DO NOT USE IN CARAVANS, TENTS, MARINE CRAFT, CARS, MOBILE HOMES, OR SIMILAR LOCATIONS.**

## IMPORTANT

- **Avoid twisting or kinking the flexible gas hose.**
- **If there is a leak in your appliance (smell of gas), immediately attempt to turn off the cylinder valve. Remove the appliance to a well-ventilated location away from any ignition source. Check for leaks using soapy water. Do not try to detect leaks using a flame.**
- **Do not attempt to move or relocate the appliance when it is operating. Extinguish the burner and allow it to cool. Disconnect the gas cylinder then move the appliance using the handle.**

## CHECKING FOR GAS LEAKS

- Check that seals between the appliance and the gas container are in place and in good condition before connecting the gas container.
- If the O-ring on the POL fitting of the gas hose is missing, worn, or damaged, you must obtain a replacement from an authorised service centre.
- **NEVER** check for leaks with a flame or pilot light.
- To safely check for leaks, use the 'soapy water' method. Coat the connection points (i.e. the connection between the hose and the hot water system, and the connection between the hose and the gas bottle) with a thin layer of soapy water. If you see bubbles appear, turn the cylinder gas control off and retighten the connection before re-testing.
- Inspect the appliance regularly for signs of wear, leaks or incorrect operation. If symptoms such as burner flares, lighting issues, hose or connection damage, or leaks from the seals or gas controls are identified, do not attempt to repair; contact customer service.
- There is a plastic ring seal inside the gas hose adaptor. If the seal is missing, worn, or damaged, you must obtain a replacement from an authorised service centre.
- To check if gas remains in the cylinder, disconnect from the appliance and hold the cylinder in a vertical position then shake from side to side. If there is a sound or feel of liquid movement inside the cylinder contains gas.
- Change the gas cylinder outside in a well-ventilated location away from people, animals, and ignition sources such as naked flames, pilot lights, and electrical equipment such as heaters.



## HANGING THE APPLIANCE

**OUTDOOR USE ONLY** – The appliance must be used outdoors only. Combustible surfaces, fabrics, and flammable materials must be kept at least 1000mm away from the sides and top of the appliance while it is operating.

The appliance is designed to be hung upright against a non-combustible vertical surface. Do not operate from a non-upright position. Doing so can be dangerous and will damage the appliance.

Do not operate the appliance in a dusty environment, or within 300mm of any electrical appliances or electrical wires.

During operation, ensure that the combustion air inlets on the sides of the unit and the combustion air exhaust on the top of the unit are kept free from obstructions.

## APPLIANCE PERFORMANCE

Important – this appliance is designed to be used with a source water temperature of 20°C or below. If the temperature of the outlet water exceeds 50°C the burners will shut off; you will be required to turn the water flow off and on again to reignite the burners.

This appliance is designed to raise the outlet water temperature by a maximum (average) of 25°C above the source water temperature. The temperature increase can be adjusted using the gas regulator and water regulator control knobs located at the front of the device. Increasing the gas flow, or decreasing the water flow, will increase the outlet water temperature.

## SAFETY FEATURES

The appliance is equipped with the following safety features:

**Over temperature sensor.** The appliance will not allow the burner to remain in operation once the outlet water temperature reaches 50°C. To relight the burner you will need to turn the water flow off and back on.

**Water flow sensor.** Water must be flowing through the system to allow the burner to ignite. If the water supply is restricted (for example: if you shut off the water flow at the showerhead), the burner will be extinguished and will not relight until the water flow recommences.

## SAFETY INSTRUCTIONS

This appliance must only be used in an above ground open-air situation with natural ventilation, without stagnant areas, where gas leakage is rapidly dispersed by wind and natural convection.

The following figures show outdoor areas suitable for use with this appliance. Rectangular areas have been used in these figures – the same principles apply to any other shaped areas.

Any enclosure in which the appliance is used shall comply with one of the following:

- A) An enclosure with walls on all sides, but with no overhead cover, such as:

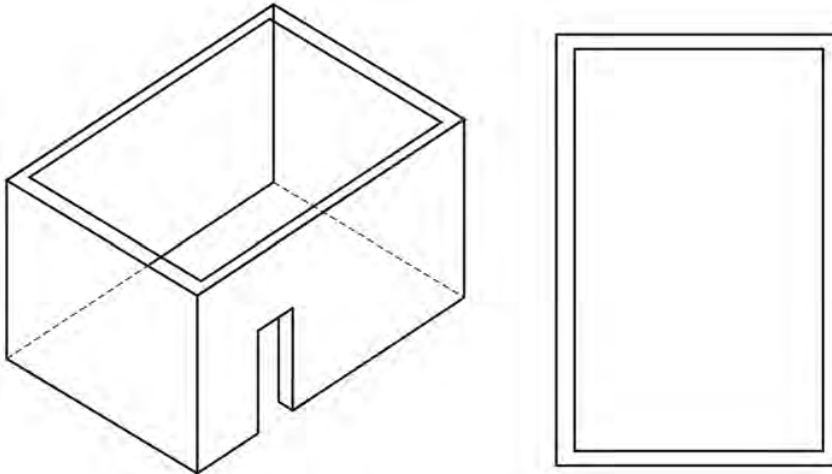

- B) Within a partial enclosure that includes an overhead cover and no more than two walls, such as:

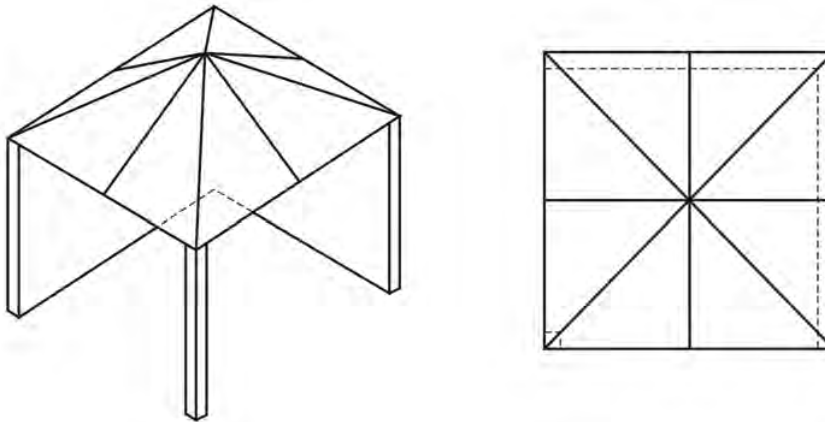

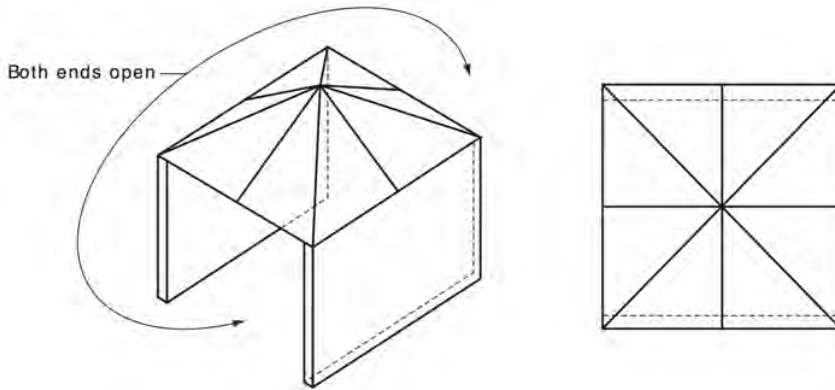



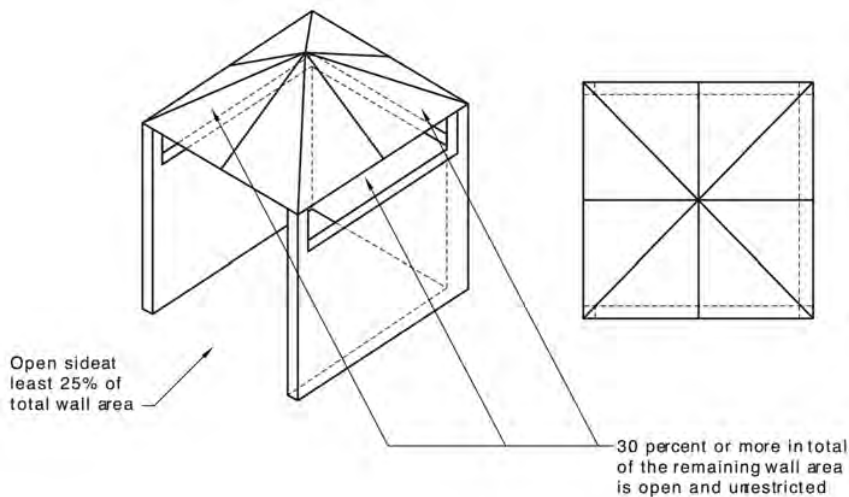
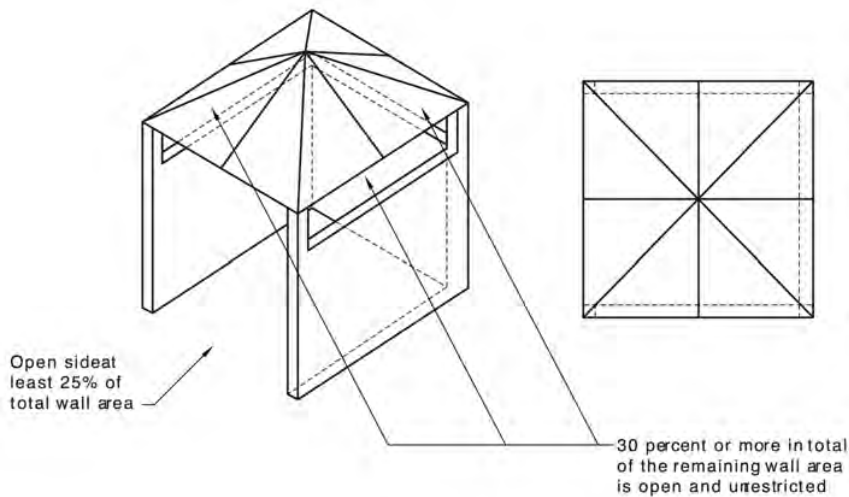

- C) Within a partial enclosure that includes an overhead cover and more than two walls, the following shall apply:
- At least 25% of the total wall area is completely open
  - 30% or more in total of the remaining wall side, back and front wall areas is open and unrestricted.
  - In the case of balconies, 20% or more of the total wall area shall remain open and unrestricted.

For example:



## PARTS INCLUDED

Description	Quantity	Identification	Remarks
Portable gas water heater	1 piece		
Shower head with shower hose	1 set		
Gas regulator with gas hose	1 set		 Test for leaks after fitting (see page 4)
Gas adaptor	1 piece		Already fitted at the factory
Water adaptor	1 piece		
Teflon tape	1 roll		
Batteries	2 pieces		
Washers	2 pieces		
Portable 12V water pump	1 piece		Not required for operation
Hanging kit	1 set		Not required for operation

## TOOLS REQUIRED FOR ASSEMBLY

- Shifting spanner



## PREPARING THE APPLIANCE

Before use, it is important to prepare the appliance by installing the proper adaptors to suit its intended use. In this example, we will be preparing the portable water heater to be used with a garden hose water input. (To use with other water input sources such as a water pump, please consult the pump instruction manual or contact us for advice).

1) Remove the heater and all components from the box and place them on a table in front of you. Remove the Styrofoam. Identify the gas input, hot water output, cold water input, and battery box on the underside of the heater.

2) Insert the two 'D' batteries into the battery box, with polarities as shown, and close the battery box lid.



3) Fit the gas hose with regulator to the gas adapter fitting on the 'gas input'. Tighten the connection with a spanner, taking care not to over-tighten as this could damage the nut or the gas inlet adaptor. Test for leaks after fitting (see CHECKING FOR GAS LEAKS on page 4).

Wrap the 'water input' thread with two rotations of Teflon tape and then install the supplied garden hose adaptor. Tighten the adapter connection with a spanner, taking care not to over-tighten as this could break or crack the inlet pipe.

4) To attach the showerhead to the supplied flexible shower hose, first place one of the supplied washers in the threaded fitting between the shower hose and showerhead. Then screw the fitting onto the showerhead.





5) Attach to the included hand showerhead. Note that you can also apply Teflon tape to this threaded connection to avoid leaks.

## OPERATING THE APPLIANCE

Now that the appliance has been prepared with the proper adapter fittings and connections for our intended use (with a garden hose water supply) we can set it up for operation.

- 1) Find a suitable sturdy, non-combustible vertical surface to hang the appliance. The surface should be at least 1000mm clear from the sides and 1000mm from the top of all combustible surfaces, fabrics, flammable materials, and people. Hang the appliance on a suitable vertical surface by the handle attached to the back cover of the heater. The appliance is ready to be connected to gas and water hoses.
- 2) Attach the flexible hose and regulator to the 'gas inlet'. Tighten this connection with a spanner, taking care not to over tighten as doing so may damage the pipe.
- 3) Connect the other end of the flexible hose and gas regulator to the propane gas cylinder. Hand-tighten the connection in an anti-clockwise direction. Note: never place the gas cylinder directly beside or above the appliance.
- 4) Turn the gas cylinder on (open) in an anti-clockwise direction one full turn, and then check the connections for leaks with soapy water. DO NOT use a flame. If a leak is detected, turn the cylinder valve off (close) and retighten all connections and retest.
- 5) Once you determine that there are no leaks present with the gas valve open, turn the cylinder valve to the off (close) position.
- 6) Place the second supplied washer inside the threaded fitting on the loose end of the shower hose. Attach this fitting to the 'water outlet' connection. If necessary, you can use Teflon tape to avoid leaks.
- 7) Prepare a garden hose with a 'quick fitting' plug and attach it to the male garden hose fitting already installed on the 'water inlet' pipe. (This appliance is also compatible with other forms of water supply including low voltage water pumps. For information on how to connect to this please consult your pump accessory instruction manual or contact us).
- 8) Ensure that the flow regulation switch on the showerhead is in the 'off' position.
- 9) **IMPORTANT:** It is important that when starting the appliance that the gas regulator is set to the minimum position, fully to the left, indicated by the thin dotted end of the curved line.
- 10) **IMPORTANT:** It is important that when starting the appliance that the water regulator is set to the maximum position, fully to the left, indicated by the thick dotted end of the curved line.
- 11) Turn the gas cylinder on in an anticlockwise direction one full turn.
- 12) Open the valve for your water supply. Water should not start to flow out of the showerhead as it is still in the 'off' position.
- 13) When ready, slide the flow regulation switch on the showerhead to the 'on' position. Water will start to flow through the showerhead within a few seconds. You should hear a series of clicks and then the burner should ignite. The burner flame can be seen operating through the viewing window located at the front of the appliance.

14) Adjust the temperature of the water flowing from the showerhead by turning the 'gas' and 'water' knobs.

- a. Turning the gas knob towards the  **Max** symbol will increase gas flow.  
Turning the gas knob towards the  **Min** symbol will decrease gas flow.
- b. Turning the water knob towards the  **Max** symbol will increase water flow.  
Turning the water knob towards the  **Min** symbol will decrease water flow.
- c. For higher temperatures increase the gas flow and decrease the water flow.
- d. You can also adjust the temperature of the water flowing from the showerhead using the 'season' control knob. The 'Summer' setting turns off some burners to save gas. The 'Winter' setting turns on all burners to provide hotter water.

**Warning! Take care to test the temperature of the water flowing from the showerhead, as it may be hot enough to cause injury.**

The water flow can be stopped at any time by sliding the regulation switch on the shower head to the 'off' position. The burner will extinguish.

To reignite the burner, slide the flow regulation switch to the 'on' position. Water will commence to flow and the burner will ignite within 5 seconds.

## WATER CYCLING INSTRUCTIONS

To achieve maximum water temperature at higher flow rates you can 'cycle' the water. To do this, pump the water from a source reservoir (such as a bucket) through the heater and back into the reservoir. You can cycle the water as many times as required to reach your desired temperature, up to 50°C.

## STORING THE APPLIANCE

- 1) After use, turn the cylinder gas valve in a clockwise direction to the 'off' (close) position. The burner will continue to operate until all gas has been bled from the hose and regulator assembly.
- 2) Wait for the flame to go out, then turn the appliance control valve(s) off.
- 3) Turn off the water supply at the garden hose tap. Disconnect the 'quick fitting' garden hose attachment from the 'water inlet'.
- 4) Disconnect the regulator and hose assembly from the appliance and gas cylinder and store away.
- 5) Disconnect the showerhead and hose from the 'water outlet', hold the shower head approximately 1 metre from the ground and allow all water to drain out before rolling up and storing away.

## DISCONNECTING FROM CYLINDER

1. Check that the appliance is fully extinguished, the gas cylinder control valve is in the fully 'off' position and all surfaces are cool.
2. Loosen the connection to the gas cylinder in a clockwise direction.

## DRAINING THE HEATER WHEN STORING BELOW 0°C

When the ambient temperature is below freezing, it is essential to drain the water after using the heater. Failure to do so will void your warranty.

1. Ensure that the heater is disconnected from the gas supply.
2. Ensure that the heater is disconnected from the water supply.
3. Ensure that the shower hose is disconnected from the heater.
4. Turn the water flow knob to  Min.
5. Operate the drain valve at the base of the appliance until all water has drained from the heater.

## CARE INSTRUCTIONS

Using warm soapy water with a mild detergent wipe down all surfaces and areas of the appliance, taking care not to allow water to enter the burner outlets.

Before each use, check that the screen filter on the 'gas inlet' and 'water inlet' pipes is in place and cleaned of any particles.

- **DO NOT submerge the appliance in a sink or bowl.**
- **DO NOT use abrasive cleaners or bleach.**

## TROUBLESHOOTING

This guide should be followed in case of failure of the appliance to operate correctly. If problems persist contact us.

### DO NOT MODIFY THE APPLIANCE. DO NOT ATTEMPT TO REPAIR THE APPLIANCE.

Problem	Cause
The appliance will not light at all	Make sure you have new batteries installed in the correct position. Check the cap of the battery case for instructions on how they should be installed.
	Check for sufficient water pressure. The unit must have a minimum of 0.25 MPa of sustained water pressure to activate the burners.
	There may be debris or epoxy residue in the water regulator. Check that the water inlet filter screen is clean. To flush the system, you can reverse the hookup by taking the water inlet pipe and hooking it up to the water outlet side and back.
	The gas cylinder may be contaminated by air. Turn the unit on and off several times to purge the air from the gas.
	Check that the shower flow water regulator is in the open position.
Water flows through the unit, but is not hot	New batteries may be required for the ignition switch. Check the cap of the battery case for instructions on how they should be installed.
	Check that the water pressure is at least 0.25 MPa to activate the burners.
	Ensure that the liquid propane regulator is threaded all the way to the unit and that you have an adequate amount of gas in your propane bottle.
	Verify that you have hooked up both the incoming and outgoing water supply properly. The showerhead should be attached to the water outlet (located at the centre) and the water inlet should be attached to your incoming connection (located at the far right) as labelled.
Water is not hot enough	Adjust the gas regulator and water regulator to meet your desired temperature. To increase temperature, turn the gas regulator control from minimum to maximum and turn the water regulator control from maximum to minimum.
	Turn the burner control knob, in the centre of the unit, to the Winter setting. This will activate more burners.
	Check source water temperature. If the source water temperature is too cold then you can 'cycle' the water (see <a href="#">WATER CYCLING INSTRUCTIONS</a> on page 11).
	Check that there is a blue flame in the 'viewing window'. If you see a yellow flame it could mean a breakdown in the gas regulator. Please call us directly if this happens; do not attempt to use the heater.

The unit starts for a short amount of time and then shuts off	Check your gas cylinder to ensure it is not empty. If using a new cylinder, try to cycle the unit on and off by using the showerhead switch several times to purge the air from the gas lines.
	You can check if the gas cylinder is empty by using a scale. Disconnect the bottle and place it on a scale, making sure the valve is firmly closed. The tare (empty) weight of the bottle is stamped on the neck ring. The difference between the scale reading and the tare weight indicates approximately how much gas is in the bottle.
	Do not expose the water heater to strong winds.
	This unit activates at a sustained water pressure of 0.25 MPa. If your supply water pressure is below the minimum, the unit will not ignite.

## SPECIFICATIONS

Model number	<b>Portable 8</b>
Injector size	<b>0.62 mm</b>
Total nominal gas consumption	<b>28 MJ/h</b>
Gas pressure	<b>2.8 kPa</b>
Min water pressure	<b>0.25 MPa</b>
Max water pressure	<b>1.0 MPa</b>
Size	<b>500 x 300 x 135 mm</b>
Weight	<b>5.3 kg</b>
Gas input connection	<b>G ¼ (with pre-fitted adaptor)</b>
Water input connection	<b>G ½</b>
Water output connection	<b>G ½</b>

## WARRANTY INFORMATION

The Luxline Portable 8 Hot Water System comes with a 2 year warranty (parts and labour), provided it has been operated and maintained as per the manufacturer's specifications outlined in the instruction manual. (These specifications comply with AS2658.)

In the event of defects arising from faulty workmanship and/or materials for a period of two years from the date of purchase, Luxline will replace or repair the unit free of charge. In accordance with Australian Consumer law, you are entitled to a refund or a replacement in the event of a major failure, and compensation for any other reasonably foreseeable loss or damage. You are also entitled to have the unit replaced or repaired if it fails to be of acceptable quality and the failure does not amount to a major failure.

When a legitimate warranty claim is made, Luxline is responsible for the cost of the repairs, which include:

- Any transport or postage costs associated with sending the Luxline Hot Water System from the repair centre to the customer.
- Parts and labour for up to two years after the date of purchase.

Luxline is not responsible for:

- Any transport or postage costs associated with sending the Luxline Hot Water System to an approved repair centre for an under-warranty assessment
- Any costs for repairs (including labour and call-out fees) where a Luxline Service Agent was not used.

### Warranty Conditions

These are the benefits provided to you by this warranty and in addition to other rights and remedies available to you under the law.

All Luxline Portable 8 Hot Water Systems must be used and serviced in accordance with the manufacturer's instruction manual (which complies with AS2658).

Any service, inspection, repair or replacement activities associated with Luxline products must only be carried out by an approved Luxline agent. To claim this warranty, the customer will need to provide proof of purchase in the form of a receipt or financial transaction statement in the name of the purchaser.

This warranty only applies to the Luxline Portable 8 Hot Water System and its internal components. The warranty does not include any accessories, fittings, attachments or pumps after the initial 30 days of purchase.

In the circumstance where a failed component is replaced under warranty, the balance of the original warranty will remain effective. The replacement part does not carry a new warranty.

If the Luxline Portable 8 Hot Water System is deemed not to be faulty or not covered under warranty, a service fee will be charged. Return postage costs will be the responsibility of the customer.

Customers who want to make a warranty claim must contact the Luxline Service Centre. No hot water systems will be assessed without proof of purchase.

### Warranty Exclusions

The warranty will become void in the following circumstances:

- The tamper sticker has been damaged or removed from the hot water system.
- The hot water system has been damaged through accidental damage, abuse, improper use, acts of god, or improper maintenance.
- The hot water system has been altered or repaired by persons other than a Luxline approved repairer.
- The hot water system has been damaged through sediment and/or sludge in the water supply.
- The hot water system has been damaged through frozen water in the pipes. (The instruction manual includes instructions for drainage).

Additionally, the warranty only applies to the original purchaser – it cannot be transferred.



1300 371 858  
[luxline.com.au](http://luxline.com.au) / [luxline.co.nz](http://luxline.co.nz)