

Job Name : \_\_\_\_\_  
 Purchaser : \_\_\_\_\_  
 Engineer : \_\_\_\_\_  
 Submitted To : \_\_\_\_\_  
 Submitted By : \_\_\_\_\_  
 Unit Designation : Schedule No.: \_\_\_\_\_

Location : \_\_\_\_\_  
 P.O. No. : \_\_\_\_\_  
 Architect : \_\_\_\_\_  
 Date : \_\_\_\_\_  
 For :  Reference  Approval  Construction  
 Model No.: \_\_\_\_\_

## Submittal Data : LA091CNP



### Capacities :

Cooling ..... 9,800 Btu/h  
 Outdoor Design Temp.(°F,DB/WB)  
 Cooling ..... 95/75  
 SEER ..... 13  
 EER..... 10

### Indoor Unit :

Power Supply (V,Ph,Hz) ..... 36V DC  
 Maximum Fuse Size..... Powered by  
 Minimum Ampacity..... Outdoor Unit  
 Weight (lbs)..... 33.1  
 Sound (dB(A),H/M/L Cool)..... 41/35/29  
 Air Circulation (CFM)..... 330  
 Dehumidification (pts/hr) ..... 3.0

### Outdoor Unit :

Power Supply (V,Ph,Hz) ..... 115,1,60  
 Maximum Fuse Size..... 15  
 Minimum Ampacity..... 9.4  
 Weight (lbs)..... 70.5  
 Sound (dB(A), High Cool) ..... 48

### Refrigerant Piping :

Maximum Length (ft)..... 50  
 Maximum Height Difference (ft)..... 25  
 Liquid Side (O.D)..... 1/4"  
 Gas Side (O.D)..... 1/2"

### Standard Features :

- Five Year Compressor Warranty
- Three Year Functional Parts Warranty
- Customizable Art Panel
- R-410a Refrigerant
- Plasma Air Purifying System
- Chaos Swing Air Circulation
- Jet Cool™
- LCD Wireless Remote Controller
- Auto Restart
- 24 Hour On/Off Timer

### Note :

### LAN091CNP

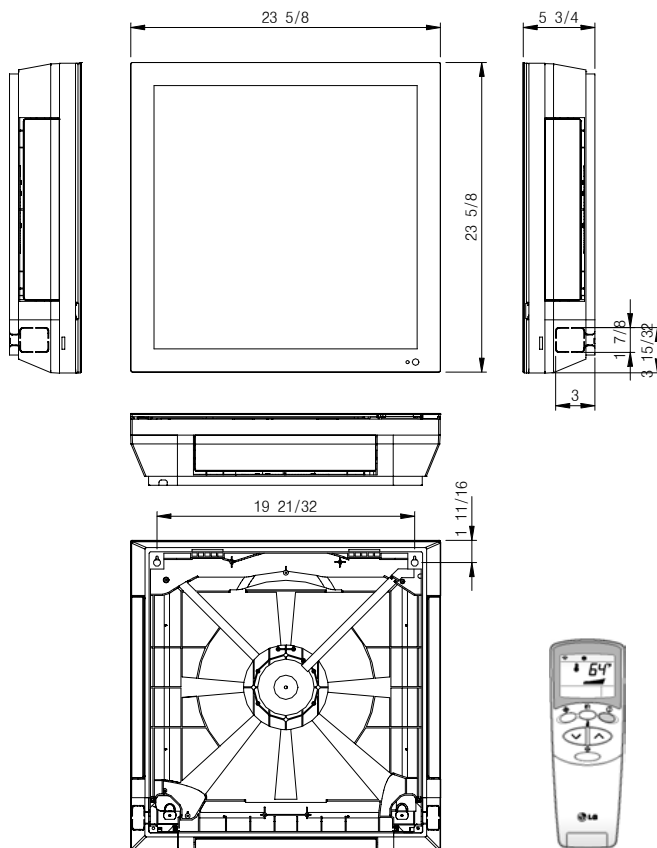

### LAU091CNP

