

Installation and User Manual/Warranty

ONLINE Drinking Water System

Model Numbers: KRAUSEN 800 WHITE

KRAUSEN 800 ADVANCE

KRAUSEN 800 EVOLUTION

Dear customer,

Thank you for purchasing KRAUSEN water purifier!

You now have water treatment equipment that is at the world's leading position in today's water treatment field. It produces pure water that can be consumed directly so the water you drink is cleaner and also beneficial to your health.

Before you install and use this water purifier, please be sure to read the user manual, this enables qualified and standardized installation as well as reasonable use and maintenance to maximize the effectiveness of your water purifier.

If you experience difficulties during installation or usage, please contact your local distributor to carry out repairs or maintenance for you.

Contents **Page**

Safety Considerations.....	3
Product Introduction.....	4
Installation Method.....	7
◆ Pre-Installation Preparations.....	7
◆ Instructions for Proper Installation.....	7
◆ Installation Notes.....	9
Adjustment Methods.....	9
Usage Methods.....	9
Maintenance and Upkeep.....	10
◆ Computer board control.....	10
◆ Filter Replacement Time.....	10
◆ Filter Replacement Method.....	11
◆ Notes	11
Failure Diagnosis and Resolution.....	11
After-Sales Service.....	12
Packing List.....	12

Safety Considerations (Be sure to read and remember these safety considerations)

In order to avoid property damage and harm to you and others, make note of the following safety precautions.

★Ignoring the following safety precautions could result in a risky situation:

⚠ Warnings If you ignore contents in this section, it may cause permanent damage to the water purifier or cause serious property damage.

⚠ Notes If you ignore the contents in this section, it may lead to damage of some parts of the water purifier or may result in some property damage.

⚠ Warnings

Do not disassemble or modify this water purifier on your own!

Unauthorized disassembly or modification of the machine could lead to machine malfunctions or leakage accidents. Please check with the store where you purchased this product for product consultation in order to arrange for repairs.



Do not put things on the top of the machine!

Obstructing the heat dissipation may lead to machine damage or fires.



Do not put heavy things on the machine!

if you put heavy things on the machine, it may damage the spare parts inside, cause the leakage, malfunction even serious property damage..



Do not use this water purifier under high water pressure conditions!

Operating under high-pressure conditions may cause the water purifier pipes to rupture, resulting in leakage, the machine working improperly, or even serious property damage. Recommended inlet pressure is 0.05MPa to 0.35MPa.



Do not let the machine come in contact with corrosive materials!

These materials could corrode the outer cover and affect the water parts or some toxic and hazardous compounds could penetrate the water purifier pipes, leading to contaminated water production and machine leakage, which could even cause bodily and property damage.



Do not put the water purifier close to the fire!

Do not put the water purifier near a fire source or place where the temperature is too high, this may cause deformation or melting of the machine, causing damage or leakage, which could lead to serious bodily and property damage.



Notes

Do not use the water purifier when the sewer is blocked up!



If it is used while the sewer is blocked, it may cause the waste water to back up or pollution to get inside the water purifier.

The waste water discharge pipe and wastewater ratio device cannot be blocked!



When the waste water discharge pipes and waste water ratio device are clogged, it may lead to high TDS effluent, the RO membrane may get blocked or the water purifier may not work.

Water purifier inlet water temperature should not exceed 38°C!



If the inlet water temperature is over 38°C, it will damage the reverse osmosis membrane leading to membrane failure.

Do not use in conditions under 5°C!

If the temperature in the room is below 5°C, please be sure to take measures to prevent freezing, such as starting the heater or air conditioner to prevent leakage or cracked pipes caused from water freezing inside the machine.



Do not use this water purifier outdoors!

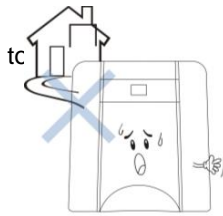

If this water purifier is used outdoors, it can lead to accelerated aging of the water purifier pipes and parts, which can cause leaking or machine failure.

Do not use the water purifier in direct sunlight!



When the water purifier is in sunlight for a period of time, it may create a breeding ground for microorganisms so the water purifier water quality will decrease, and they may pollute the internal components of the water purifier.

Product Introduction

1. Blown-up profile of the water purifier

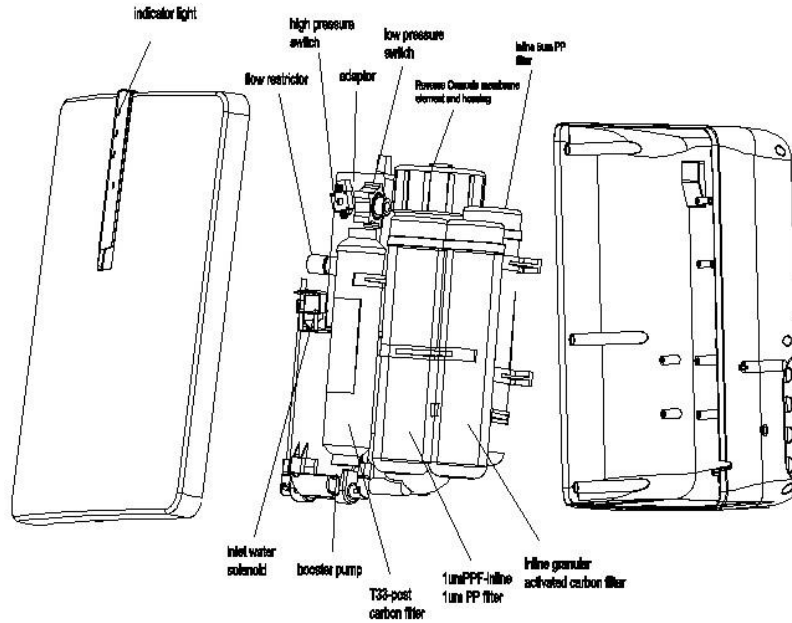

1 (a)

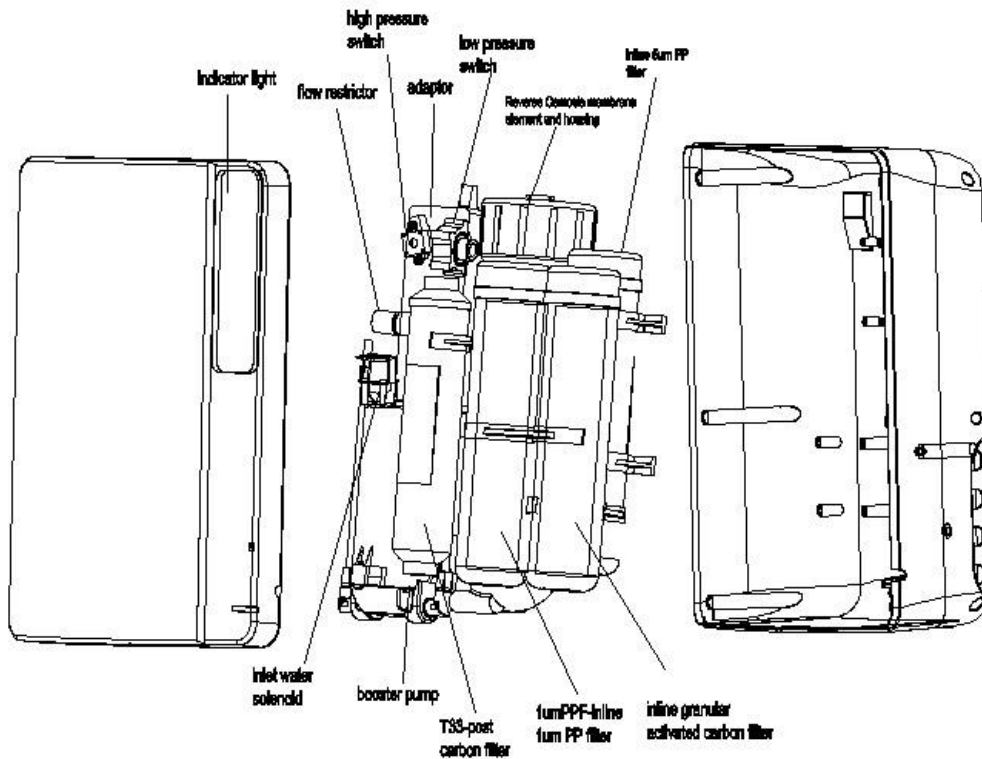

1 (b)

2. Electrical diagram

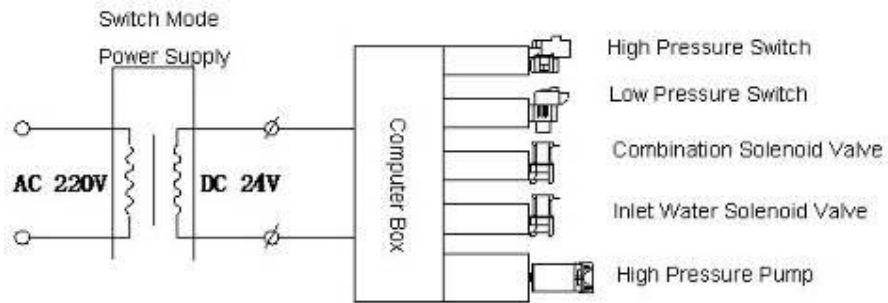

Diagram 2

3. Water route map

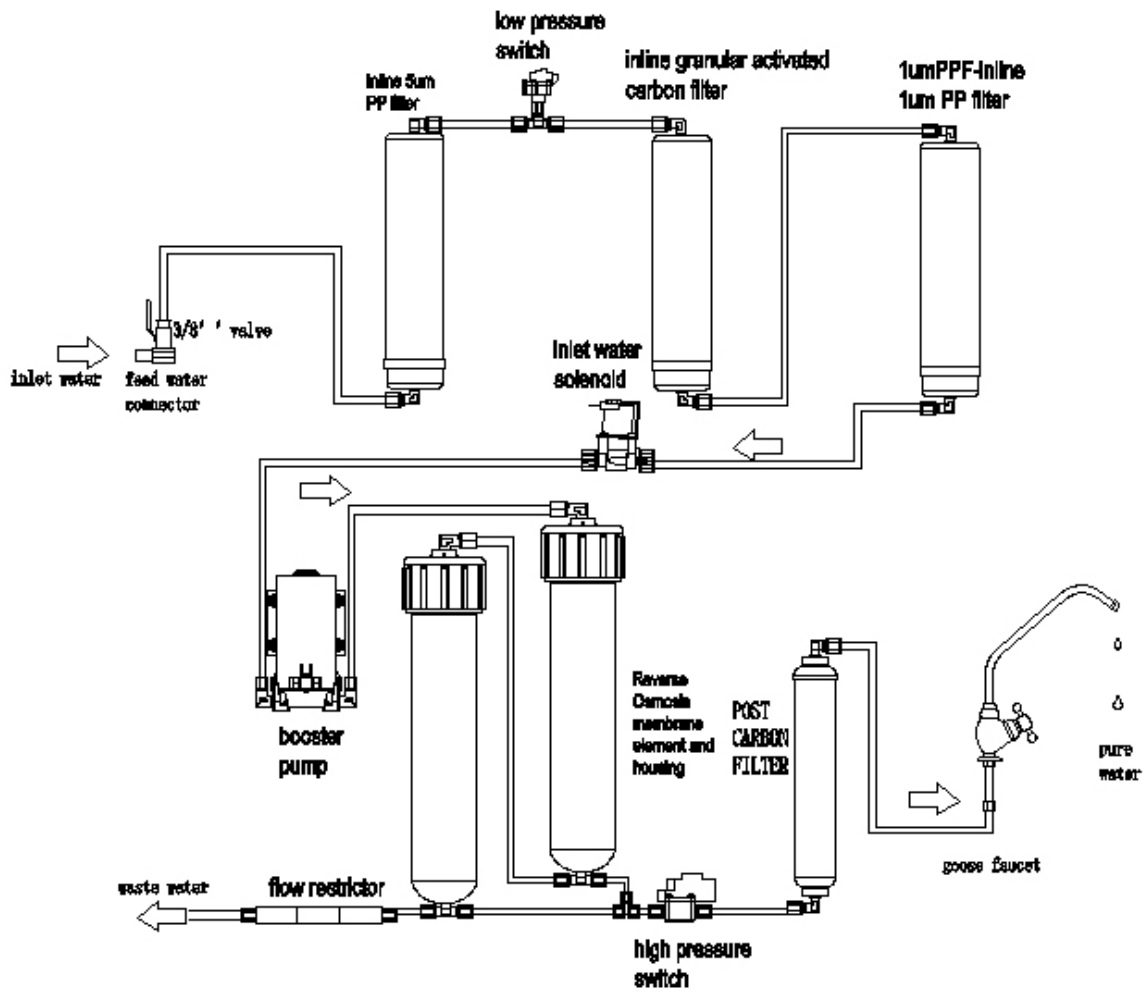

Diagram 3

4. Technical Parameters

Voltage	AC 220V 50HZ
Power Rating	75W
Suitable Water Pressure	0.05MPa~0.35MPa
Operating Pressure	≤0.85MPa
Inlet Temperature	5-38°C
Maximum Inlet Water TDS Value	≤1000PPM
Maximum Daily Water Production Volume	800 Gallons, approximately 2880 Liters
Electric Shock Protection Type	Type II
Suitable Water Quality	Municipal tap water meeting the GB5749-2006 standards

Note: Due to product improvements, the above parameters may change but the product name plate shall stay the same. TDS refers to the influent total dissolved solids.

5. Water Purifier Main Parts Function Introduction

Using the current most advanced international RO technology, **standard configuration** is as follows:

① First is a Inline 2.5` 5-micron PP filter:

The aperture of the PP filter is 5 microns, can effectively filter rust, sand, other larger particles and solid impurities in water.

② Second is a Inline 2.5` granular activated carbon filter:

Can effectively adsorb chlorine, humus, disinfection by-products, odors, colors, and other materials.

③ Third is Inline 2.5` 1-micron PP filter:

Can further remove small particles in the water, suspended solids, colloids, etc.

④ Fourth stage is 2 x RO membranes:

Aperture is 0.0001 micron (0.1 nm), reduces bacterium by 4,000 fold, reduces viruses by over 200 fold, so you can effectively remove bacteria, viruses, heavy metals, pesticide residues, and other harmful substances from the water.

⑤ The fifth-stage is a post-activated carbon filter:

Regulates water taste, keeps water fresh.

Note: This machine also has an optional configuration:

Pretreatment Filter: KDF two stage filter, KDF three stage filter

Post-filter: Alkaline filter, infrared mineralization activated carbon filter, alkaline sterilization filter, sterilizing filter

6. Water Purifier Accessory Functions

High Pressure Pump:	Boosts pressure to create a stable environment for the RO membrane.
Low Voltage Switch:	To prevent pump idling. When the inlet water pressure is less than 0.03 MPa or when the inlet water stops, the low-voltage switch automatically shuts off the power source so the machine stops.
High-Voltage Switch:	Prevents pump from fully turning. When the pressure tank is full or has reached the set pressure, power supply is automatically cut off to stop the machine.
Inlet Water Solenoid Valve:	Connects or cuts off incoming water. Operating pressure range is less than 0.6MPa.
Non Return Valve:	controls the flow direction.
Flow restrictor:	control the ratio of pure and waste water

7. Direct flow purifier features:

1. **Design without storage tank:** New advanced design. The water flow is equal to the normal one with tank. The user can get the pure water at the same time the machine is producing water. This design solves the contamination problem (such as odors, bacteria etc) caused by long time pure water storage in tank. It supplies the real “pure and fresh water”.
2. **Large Production Capacity and Big Water Flow:** Use a 2 x 400G RO membranes. The production capacity is 15-16 times of the standard 50G one, and is equal to the water flow of 50G model with tank. It can reach 1.5L/min~2.0L/min
3. **Suitable for low water pressure:** It can start working if the feed water pressure is no less than 0.03Mpa.
4. **Digital Computer Box Automatic Control System:** The system can automatically control the water auto flush process for the RO water purifier to ensure more reliable and safe operation of this machine;
5. **Indicator light Display:** Indicator light show the working status, it is easy for the maintenance.
6. **The inlet and outlet water is on the side:** easy for the machine's installation.
7. **Quick connector: New advanced design, quick connectors make it easy for installation, usage and maintenance.**
8. **Inline filter, easily dismantle: only dismantle the inline filter to make easily changing**

Installation Method

This company recommends that professionals install the machine for you, because you must use drills and other power tools in the installation process. If you are installing it yourself, please refer to the following steps and diagrams:

1. Pre-Installation Preparations

- ① Confirm the location the water purifier will be installed (when installing, it should depend on the actual circumstances)
- ② Confirm the various tools required for installation

Adjustable spanner	1
Drill	1
6.2mm drill bit	1 (waste water hole)
Hole saw, ϕ 14mm	1 (high-speed steel or marble hole saw)
Phillips and flathead screwdrivers	1 of each
Scissors	1 pair
18-21mm wrench	1
14-16mm wrench	1
Needle nose pliers	1
- ③ Confirm that you have all the connectivity accessories required for installation
- ④ Prior to installation turn off the water and/or electricity

2. Instructions for Proper Installation

- ① Inlet water metal hose and 3-way inlet water joint installation method (if the metal hose diameter is 3/8" the 3-way inlet water joint must be purchased separately)
First close the inlet water valve. Unscrew from the metal hose. Remove the 3-way inlet water joint from the water purifier accessories box, thread one end of the inlet water 3-way joint into the inlet water valve outlet; one end of the newly unscrewed metal hose should be screwed into the 3-way inlet water joint screw nut (See Diagram 4).

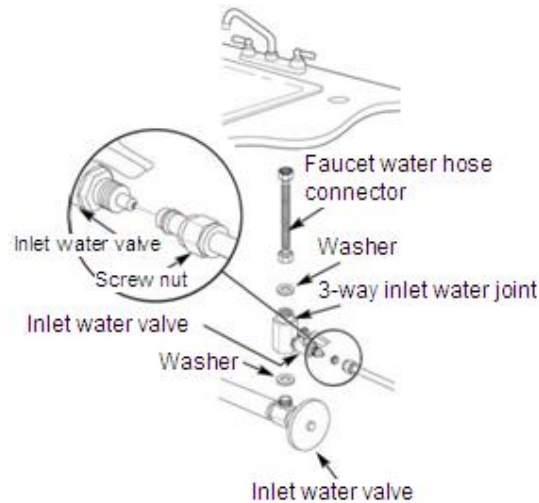

Diagram 3

② 3-way inlet water joint and inlet water ball valve installation method

Take out the inlet water ball valve from the water purifier accessories box, wrap one end of the ball valve external threads with the appropriate Teflon tape (See Diagram 5), if you have silica gel, spread a little on and then screw the ball valve into the corresponding hole of the 3-way inlet water joint (See Diagram 6). Take out the Ø 9mm water pipe from the accessories box, using scissors cut a suitable length of pipe, connect one end of the pipe with the inlet water ball valve (See Diagram 4), finally screw the nut in place.

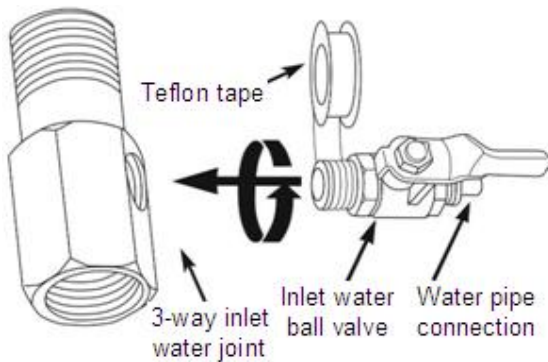

Diagram 5

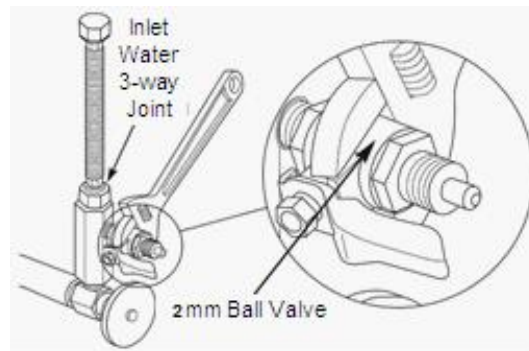

Diagram 6

③ Gooseneck faucet installation

In the counter where the faucet is to be installed drill a $\phi 14\text{mm}$ hole in an appropriate position, then take out the faucet from the water purifier accessory box. Start the faucet installation: first put the stainless steel neck on the faucet main body (See Diagram 7), then lower the main part of the faucet into the already drilled hole, and then put the spacer on the lower part of the faucet. Screw the fixed nut into the bottom end of the faucet to fix the faucet to the counter, finally put the

appropriate length of Ø6mm pipe into the water inlet connection, put on the nut and hollow ball, screw to the bottom of the faucet (see Diagram 7). If you want to fix the faucet to the wall, please use the faucet hanging piece. (when installing be sure to tighten the joints to prevent leakage)

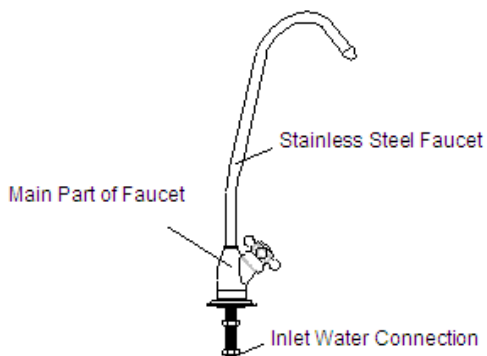

Diagram 7

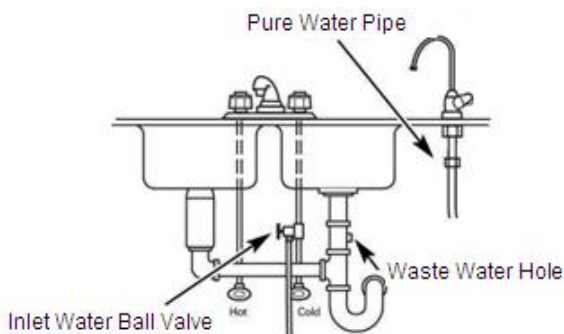

Diagram 8

④ Waste water pipe installation

Using a φ6mm drill punch a small hole into the sink drain pipe, take a suitable length of the 6mm water pipe, lay one end just inside the hole (See Diagram 8), put some silica gel where the 6mm pipe and the drain pipe connect to prevent leakage, use a cable tie to fix the waste water pipe to the drain pipe. (for large flow water purifiers you need waste water clip inserted into the already drilled drain pipe hole)

⑤ RO Membrane Installation

First take the water purifier out from the packaging, open the water purifier outer cover, unscrew the membrane shell cover inlet water connection end, take out the inlet water pipe, then use the membrane shell wrench to unscrew the membrane shell cover. Take the RO membrane from its packaging, put the end of the membrane with the O-ring into the reverse osmosis membrane shell (See Diagram 9) and push it in, finally screw the membrane shell cover back on, and use the membrane shell wrench to tighten the membrane shell cover, put the inlet water pipe into the membrane shell inlet water connector and screw in the nut, then put the membrane shell card into the large single clip and put the water purifier cover back on.

! Warning:

- ◆ When installing the RO membrane, you should pay attention to the direction of the membrane;
- ◆ When installing the RO membrane, you should first make sure that one end of the membrane has two O-ring;
- ◆ When installing, be sure to put the end with the O-ring into the end of the membrane shell with the pure water connection, when installing correctly you only need a little force to put the reverse osmosis membrane into the membrane shell, if you encounter too much resistance, please do not force the reverse osmosis membrane into the membrane shell, doing so may cause permanent damage to the membrane shell or membrane components (the membrane manufacturer does not assume responsibility for returned components due to damage during installation);
- ◆ Damage to the membrane shell and reverse osmosis membrane element caused as a result of the above reasons is not covered under the water purifier warranty.

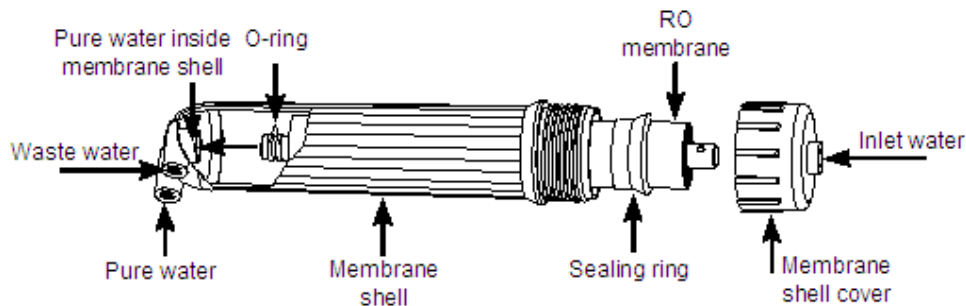

Diagram 9

3. Installation Considerations

- ① When installing the water pipes, cannot install a drain stopper, in addition, for the water pipe bottom connector, the screw nut should have no wire teeth exposed.
- ② If the inlet water pipe is 9mm, should ensure that the inlet water tube and connector have 30-40cm of straight piping to avoid burst pipe accidents caused by bending in the pipe.
- ③ If the power cord wiring needs to be longer, then according to the wiring requirements use a $\Phi 8\text{mm}$ pinched tube to wrap around the connection, then on the outside wrap around insulating electrical tape, do not place it on the floor, it should be suspended in the air or in another place away from the ground.
- ④ When installing, if you need to make a hole in the wall, you should first make sure that there are no electricity or water lines in the location you plan to drill.
- ⑤ This machine must be connected to the safety socket that has the earth wire. Otherwise the manufactory should not be responsible for any accident.
- ⑥ This machine is installed with the adaptor, it must not touch in much water when installing, otherwise it would cause the electrical accident.

Adjustment Methods

After confirming that the water route connections are correct, confirm that you have a power supply and/or water supply. Then follow these steps to troubleshoot the machine:

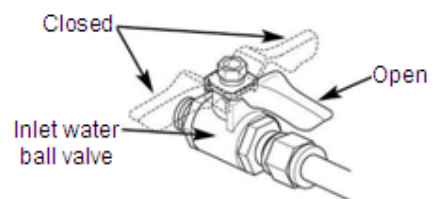

Diagram 10

1. Open the tap water inlet valve as well as the water purifier inlet water ball valve, plug in the power source (See Diagram 10), close the storage tank ball valve, then automatically start a 120 second flushing process, water will start to drain through the discharge outlet.
2. Wait for the water purifier to operate stably (about 5-10 seconds), check each connection to make sure it is secure, see if there is any leakage from the membrane shell, filters, etc.
3. Close the pure water gooseneck faucet and storage tank ball valve, wait approximately 30 seconds, check whether or not the water purifier waste water has stopped.
4. Open the gooseneck faucet, observe whether pure water is flowing through the faucet, if no pure water is flowing, check whether the tap water pressure is too low or whether the high pressure

switch cannot be reset.

5. Wait until the machine is operating, close the inlet water ball valve, after a short time observe whether it has stopped operating, if it has stopped operating, check whether the low-voltage switch can be reset.
6. Wait some time to make sure everything is correct, then the water purifier can be used safely.

Usage Methods

1. The major components of this product are plastic, when using the product always observe the integrity of the water purifier to ensure safe use.
2. In order to prevent microbial contamination of membrane components during storage and transportation the reverse osmosis membrane element package contains a small amount of protective solution while the post-activated carbon filter will emit activated carbon powder the first time it is used. So for the first hour the water purifier is operated, do not open the water storage tank. It is recommended that the water produced is thrown out, otherwise the pure water taste may be unusual.
3. When you start operating the water purifier the pure water TDS value may be a little high, after running for some time the TDS value for pure water will gradually decrease until it is stable.
4. When you are using the water purifier, the inlet water ball valve should be opened and the pure water faucet needs to be turned on. When you are not using water turn off the water faucet, the high pressure switch will automatically cut off the water supply.
5. In these “usage methods”, “usage” refers to when the power supply is connected and/or the inlet water ball valve is open so the water purifier is in a working condition.

Maintenance and Upkeep

1. Filter Replacement Time

- ① This machine's filter replacement cycle for the various filters is derived from statistical indicators on average tap water use estimates. If there are big discrepancies between the user's actual water quality and utilization rate and the average indicators, there will be more obvious differences between the filter's actual use time and the estimated cycle such as premature filter clogging, premature failure, etc. If this happens, filter replacement should be based on actual use, you should also promptly contact your local after-sales service department.
- ② This machine's estimated filter replacement cycle is based on average household water consumption and is suitable only for residential use, do not install this machine in places that require large volumes of water. If the water volume requirements are large, this company has appropriate machines for business purchase.
- ③ According to economic statistics on municipal tap water, a three person family on average uses 10L of water a day, according to the water volume and inlet water quality conditions, overall filter volume is approximately as follows (the following data is for reference only):

Progression	Water Volume (tons)
First: Inline 2.5` 5-micron PP filter	7.5
Second: Inline 2.5` 85C granular activated carbon filter	7.5
Third: Inline 2.5` 1-micron PP filter	10
Fourth: RO membrane	According to the using conditon
Fifth: Post-activated carbon filter	6

Note: It is recommended that filter element replacement is carried out by after-sales staff. Water quality has a great influence on the life of the filter, the RO membrane's lifespan is affected by many factors, the above table expresses lifespan under standard conditions, in actual usage, because the water quality may be different, the lifespan may exceed the above estimate, it may also be lower than the estimate, this data is for reference only. Under normal circumstances if the following situations are experienced, you should consider replacing the filter:

- ◆ Poor water quality, taste declines, TDS value of water rises;
- ◆ Water flow is significantly reduced, check to see if the filter or membrane is blocked (and determine that it was not caused by a temperature drop);
- ◆ If the filter's outer surface is covered in mud or the filter has significantly changed color;
- ◆ If serious filter clogging leads to no pure water from the water purifier.

2. Filter Replacement Method

① Replacing the filters

First close the inlet water ball valve and unplug the power supply. Open the front cover of the machine. Unscrew the nuts on both sides of the old filter, and pull out the water pipe. Take out the old filter and remove the connectors on both ends. Wrap each of the connector with Teflon tap (If you have silica gel, it's better to have a little on), then mount onto the both ends of the new filter. Finally assemble the water pipe back and place the filter back onto the single clip. Pay attention to the arrow on the filter, and connect pipes according to arrow indicating (left—water inlet, right—water outlet).

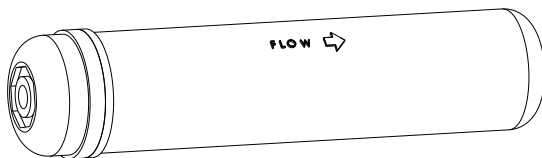

Diagram 12

② For replacement of membrane elements please see “RO Membrane Installation” (Page 10).

3. Computer box control

(a) indicator light display (from top to bottom): 1.full, 2.sleep, 3.shortage, 4.leakage。



full	This light will be on when the tank is full
sleep	The machine is not working now
shortage	The low pressure switch is shut off, check the inlet water and its pressure,
leakage	The needle on the bottom show the league inside, pls check the pipe or the connector.

A

(b) indicator light display (from top to bottom): 1.full, 2.sleep, 3.shortage, 4.leakage。



full	This light will be on when the tank is full
sleep	The machine is not working now
shortage	The low pressure switch is shut off, check the inlet water and its pressure,
leakage	The needle on the bottom show the league inside, pls check the pipe or the connector.

B

The computer box controls the working status, to ensure the machine work normally, and the RO membrane is in excellent working condition.

1. The machine will protect itself by stopping to work too long time in sleep condition. (this machine is for domestic use, it would not happen to sleep condition when use normally. Only you forget to close the faucet or exceed the standard volume, the computer box would automatically stop the machine for protection.)
2. when the light turns on from the top to bottom, it means working normally.
3. when the light shines, it means you need to change the filter. Light 1,2,3,4 separately represent the first, second, third and fifth stage filter
4. If the machine continuously works more than 45 minutes, it would stop 45 minutes for protection(sleep condition). After the sleep period, the machine can work normally.
5. when the inlet water comes from the shortage condition to normal water pressure, the low pressure switch will last 5 seconds to normal work, and at that time the shortage light will be on for 5 seconds.
6. when the leakage needle examine the water leakage, the machine will delay 5 seconds to stop, in

this condition the light will keep the same before leakage, then the leakage light will be on. If the leakage disappears, the machine will delay 10 minutes (leakage light is still on) to the former normal work..

7. when it comes to the filter life span, the step to the original: press the moving button on the full condition, when heard the reminding voice, the full light shining means the first stage filter is ready to renew. Press the renew button and heard the reminding voice, then the full light keep turning on, now the first stage filter finished renew. When you want to renew the second, third, and fifth stage filter, pls press the moving button until it comes the corresponding shining, then follow the above step.

A is for moving button, B is for renew button.

4. Notes

- ① RO membrane water production volume

The RO membrane component water volume is influenced by the inlet water pressure and water temperature, this machine's stated volume of 800GPD is tested with net pressure of 0.5MPa and inlet water temperature of 25°C, if the net pressure is less than 0.5MPa or if the inlet water temperature is less than 25°C, the RO membrane element water production will be less than 800GPD.

- ② Disposal of old filters

After replacing old filters, they cannot be cleaned and reused; it is recommended that you dispose of them with solid waste garbage



Notes

★ When any of the following situations occur, immediately disconnect the water purifier water source (close the inlet water ball valve) and/or the power source and carry out repairs.

- If the water purifier pipes or related components are leaking.
- If the water purifier's related components stop working.
- If any components leak electricity.
- If there are any other anomalies or failures.

★ When you go out or do not use the machine, disconnect the water purifier water source (close the inlet water ball valve) and/or power source.

★ If the water purifier parts are damaged, it is recommended that the water purifier be entrusted to the manufacturer or distributor, service center, or specialized technical personnel for replacement to prevent loss caused by improper operation, the manufacturer is not liable for losses caused by operation or use not in accordance with the instructions and reminders

Failure Diagnosis and Resolution

Failure Experienced	Reason	Resolution Method
The machine will not start	<ul style="list-style-type: none"> The power source is not connected 	<ul style="list-style-type: none"> Check the power source or the power source plug
	<ul style="list-style-type: none"> Low inlet water pressure or no water 	<ul style="list-style-type: none"> Check the inlet water pressure
	<ul style="list-style-type: none"> Low-pressure switch failure, cannot connect the power source 	<ul style="list-style-type: none"> After connecting the inlet water, measure the resistance, replace
	<ul style="list-style-type: none"> High-pressure switch cannot be restored 	<ul style="list-style-type: none"> After letting off the pressure, measure the resistance, replace
	<ul style="list-style-type: none"> Switch Mode Power supply is burned out 	<ul style="list-style-type: none"> Measure the output voltage, replace
	<ul style="list-style-type: none"> Fuse in the computer box burned out 	<ul style="list-style-type: none"> Measure the output voltage, replace
The high pressure pump is working properly, but no water is being produced	<ul style="list-style-type: none"> High-pressure pump has lost pressure 	<ul style="list-style-type: none"> Measure the water pump pressure, replace
	<ul style="list-style-type: none"> Inlet water solenoid valve is faulty, no water can get in (no pure water) 	<ul style="list-style-type: none"> Replace the solenoid valve
	<ul style="list-style-type: none"> A pre-filter is blocked 	<ul style="list-style-type: none"> Observe the pure water and waste water, replace the pre-filter
	<ul style="list-style-type: none"> Non return valve is blocked (waste water, no pure water) 	<ul style="list-style-type: none"> Replace the non return valve
	<ul style="list-style-type: none"> The RO Membrane is plugged 	<ul style="list-style-type: none"> Clean or replace the RO membrane
The machine is turned off but waste water has not stopped	<ul style="list-style-type: none"> Inlet solenoid valve failed, cannot effectively cut off the water supply 	<ul style="list-style-type: none"> Observe the waste water, replace the inlet solenoid valve
	<ul style="list-style-type: none"> Non return valve has lost pressure (small waste water flow rate) 	<ul style="list-style-type: none"> Observe the waste water, replace the non return valve
After the machine is filled with water (stand by), the machine starts repeatedly	<ul style="list-style-type: none"> Non return valve has lost pressure 	<ul style="list-style-type: none"> Replace the non return valve
	<ul style="list-style-type: none"> High-pressure switch failure 	<ul style="list-style-type: none"> Replace the high pressure switch
	<ul style="list-style-type: none"> System is exhibiting a loss of pressure 	<ul style="list-style-type: none"> After checking the non return valve, check whether there is water leakage in the pipelines
The pure water flow is small or not flowing	<ul style="list-style-type: none"> Pre-filter is plugged 	<ul style="list-style-type: none"> Replace the pre-filter
	<ul style="list-style-type: none"> RO membrane is plugged 	<ul style="list-style-type: none"> Wash or replace the RO membrane
	<ul style="list-style-type: none"> Inlet solenoid valve failure 	<ul style="list-style-type: none"> Replace the inlet solenoid valve
	<ul style="list-style-type: none"> High pressure pump pressure is not enough 	<ul style="list-style-type: none"> Measure the high pressure pump water pressure, replace

After-Sales Service

1. The warranty is valid from the date of installation.
2. Warranty period: One-year machine warranty. The warranty does not include consumables (consumables include filters, RO membranes, and storage tanks).
3. Please keep the warranty in a safe place, for maintenance you must have your purchase invoice, only then is the warranty effective.
4. No invoice, altered machine number, the user replacing parts or modifying the water purifier on their own, the user not following the requirements of the user manual, and men-made damage do not fall under the scope of the warranty.
5. If your water purifier exhibits abnormal behavior, please immediately turn of the water source, cut off the power, and contact your local vendor.

Notes:

The company reserves the right to change product design, configuration, and specifications without notice.

The company has the final explanation rights if this manual is unclear, has mistakes, or if there were printing problems which caused problems.

Packing List

· Main machine (including 2 x RO membranes)	1 unit
· Water pipe (ø6mm and ø9mm)	Each 1 roll
· Installation and User Guide	1 copy
· Gooseneck faucet	1
· Membrane shell wrench	1
· Accessory pack	1 package

Notes:

Unit Conversion: $0.1\text{MPa} = 1.02\text{Kg/cm}^2 = 14.5\text{Psi}$

$1\text{Psi} = 0.07\text{ Kg/cm}^2$

$1\text{ Gallon} = 3.785\text{ Liters}$