



# 550R RECUMBENT BICYCLE

MODEL NO. \_\_\_\_\_

SERIAL NO. \_\_\_\_\_

The Model and Serial numbers are located on frame just below the motor hood cover. Please write down these numbers in the spaces provided above for future reference.

## QUESTIONS?

DO NOT RETURN this product to the store where purchased.

CALL OUR TOLL FREE HELPLINE

USA: (888) 340-0482  
Canada: (800) 897-6025

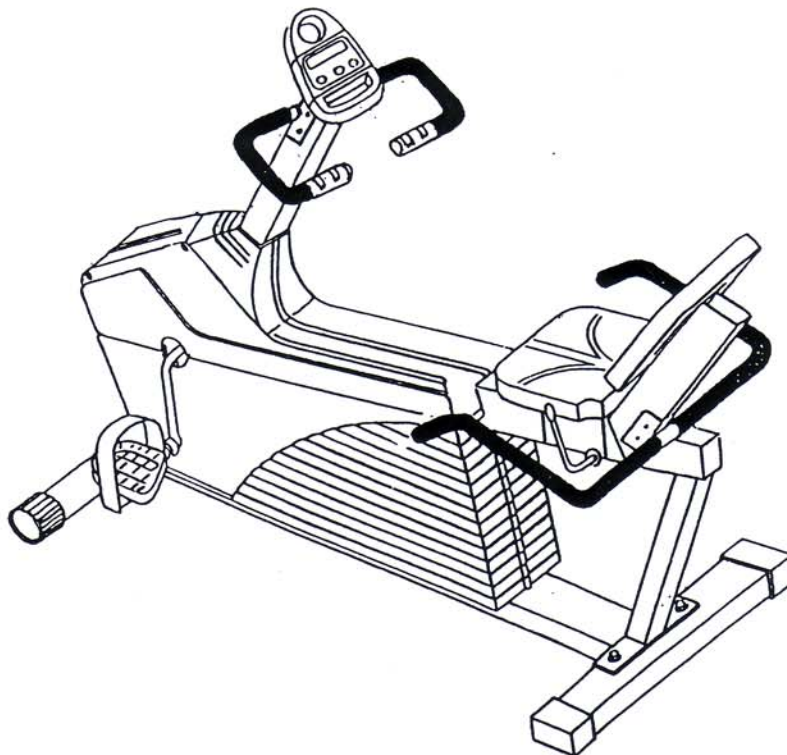

## CAUTION!

Please read the precautions and instructions in this manual before using this equipment. Please save this manual for future reference.

# OWNER'S MANUAL

KEYS FITNESS PRODUCTS, L.P.  
PO Box 551239  
Dallas, Texas 75355-1239

MADE IN TAIWAN

# KEYS FITNESS LIMITED WARRANTY

## 1 YEAR FRAME & 1 YEAR PARTS

**WARNING: Before beginning this or any exercise program consult your physician. This is especially important for persons over the age of 35 or persons with pre-existing health problems. Read all instructions in this manual before using this product. KEYS FITNESS assumes no responsibility for personal injury or property damage sustained by or through the use of this product.**

This Warranty applies only in the United States to products manufactured or distributed by Keys Fitness, Inc. under the Keys Fitness brand name. Keys Fitness warrants that the Product you have purchased for non-commercial, personal, family, or household use from Keys Fitness or from an authorized Keys Fitness reseller is free from defects in materials or workmanship under normal use during the warranty period. Your sales receipt, showing the date of purchase of the product, is your proof of the date of purchase. This warranty extends only to you, the original purchaser. It is not transferable to anyone who subsequently purchases the Product from you. It excludes expendable parts. This Warranty becomes VALID ONLY if the Product is assembled / installed according to the instructions / directions included with the product.

To obtain warranty service, you must return the product and/or the defective part to Keys Fitness in its original container (or equivalent). You must pre-pay any shipping charges, export taxes, customs duties and taxes, or any other charges associated with transportation of the Product. In addition, you are responsible for insuring any Product shipped or returned. You assume the risk of loss during shipment. You must present Keys Fitness with proof-of-purchase documents (including the date of purchase). Any evidence of alteration, erasing or forgery of proof-of-purchase documents will be cause to void Warranty. This warranty covers only parts, not labor or receive charges for installation. This warranty does include wear and tear on all parts.

This Warranty does not extend to any Product not purchased from Keys Fitness or from an authorized Keys Fitness reseller. This warranty does not extend to any Product that has been damaged or rendered defective; (a) as a result of accident, misuse, or abuse; (b) by the use of parts not manufactured or sold by Keys Fitness; (c) by modification of the Product; (d) as a result of service by anyone other than Keys Fitness, or an authorized Keys Fitness warranty service provider. Should any product submitted for Warranty service be found to be ineligible, an estimate of repair cost will be furnished and the repair will be made if requested by you upon Keys Fitness receipt of payment or acceptable arrangement of payment.

EXCEPT AS EXPRESSLY SET FORTH IN THE WARRANTY KEYS FITNESS MAKES NO OTHER WARRANTIES, EXPRESSED OR IMPLIED INCLUDING ANY IMPLIED WARRANTIES OF MERCHANTABILITY AND FITNESS FOR A PARTICULAR PURPOSE. KEYS FITNESS EXPRESSLY DISCLAIMS ALL WARRANTIES NOT STATED IN THIS WARRANTY. ANY IMPLIED WARRANTIES THAT MAY BE IMPOSED BY LAW ARE LIMITED TO THE TERMS OF THIS WARRANTY. NEITHER KEYS FITNESS NOR ANY OF ITS AFFILIATES SHALL BE RESPONSIBLE FOR INCIDENTAL OR CONSEQUENTIAL DAMAGES. SOME STATES DO NOT ALLOW LIMITATIONS ON HOW LONG AN IMPLIED WARRANTY LASTS OF THE EXCLUSION OR LIMITATION OF INCIDENTAL OR CONSEQUENTIAL DAMAGES, SO THE ABOVE LIMITATIONS OR EXCLUSION MAY NOT APPLY TO YOU. This Warranty gives you express warranty applicable to Keys Fitness branded products. Keys Fitness neither assumes nor authorizes anyone to assume for it any other express warranty.

Before returning a product you must call Keys Fitness at 1-888-340-0482 to obtain a Return Authorization Number. No returns will be accepted without the Return Authorization Number.

Original purchaser must pre-pay all freight charges on warranty claims. Keys Fitness will not accept Freight Collect shipments or return shipments on freight collect basis.

You must fill out Warranty Registration Card completely, and return it to KEYS FITNESS within 30 days of purchase for this warranty to be valid. Be sure to include a copy of your original receipt.

**KEYS FITNESS  
P.O. Box 551239  
DALLAS, TEXAS 75355-1239**

# Important Safety Information

## WARNING!

- 1) Before using this recumbent bicycle or starting any exercise program, consult your physician. This is especially important for persons over the age of 35 and/or persons with pre-existing health problems. Keys Fitness Products LP assumes no responsibility for personal injury or property damage sustained by or through the use of this product.
- 2) To reduce the risk of electrical shock, burns, fire, or other possible injuries to the user, it is important to review this manual and the following precautions *before* operation.

## SAFETY PRECAUTIONS AND TIPS

- It is the owner's responsibility to ensure that all users of this recumbent bicycle have read the Owner's Manual and are familiar with warnings and safety precautions.
- This recumbent bicycle has a user maximum capacity of 400 pounds.
- The recumbent bicycle should only be used on a level surface and is intended for indoor use only. The recumbent bicycle should not be placed in a garage, patio, or near water. Keys recommends a bicycle mat be placed under the bicycle to protect floor or carpet and for easier cleaning.
- Wear comfortable, good-quality walking or running shoes and appropriate clothing. Do not use the recumbent bicycle with bare feet, sandals, socks or stockings!
- Always examine your recumbent bicycle before using to ensure all parts are in working order.
- Do not leave children unsupervised near or on the recumbent bicycle.
- Never operate the recumbent bicycle where oxygen is being administered, or where aerosol products are being used.
- Never insert any object or body parts into any opening.
- Service to your recumbent bicycle should only be performed by an authorized service representative, unless authorized and/or instructed by a Keys technician. Failure to follow these instructions will void the warranty.

## **Before You Start**

Thank you for purchasing a Keys recumbent bicycle! This quality product you have chosen was designed to meet your needs for cardiovascular exercise.

- Before you start, please read the Owner's Manual and become familiar with the operation of your new recumbent bicycle.
- If you are taking medication, consult your physician to see if the medication will affect your exercise heart rate.
- If you have heart problems, you are not active, and/or are over the age of 50 years, do not use the pre-set recumbent bicycle programs or start an exercise program without first contacting and getting approval from your physician.
- To avoid the risk of electrical shock, always keep the console dry. Do not spill liquids on the console. Keys recommends a sealed water bottle for beverages consumed while using the recumbent bicycle.

**CM550R**  
**KEYS FITNESS WARRANTS**  
**THIS PRODUCT FOR**  
**PERSONAL, FAMILY, OR**  
**HOUSEHOLD USE ONLY.**  
**THIS PRODUCT IS NOT FOR**  
**COMMERCIAL USE.**

**WEIGHT LIMIT 400LB**

**WARRANTY :**

**FRAME 1YRS**

**PARTS 1YRS**

# Assembly Instructions

Attach **HANDLEBAR** to **BACK SUPPORT BRACKET** with two **M8 x 45 BUTTON HEAD SCREWS**, two **M8 FLATWASHERS**, and two **M8 LOCKNUTS**.

Securely tighten **M8 LOCKWASHERS**.

Insert **SEAT CARRIAGE** into **FRAME**. Fasten with **M8 x 15 BUTTON HEAD SCREWS** and **M8 FLAT WASHERS**.

Pull up **CAM LOCK** to loosen.

Insert **SEAT SUPPORT BRACKET** into **SEAT CARRIAGE**.

Pull down **CAM LOCK** until tight to **remove any looseness**.

## IMPORTANT

**CAM LOCK** must be pulled down tightly before you sit on the **SEAT CUSHION**.

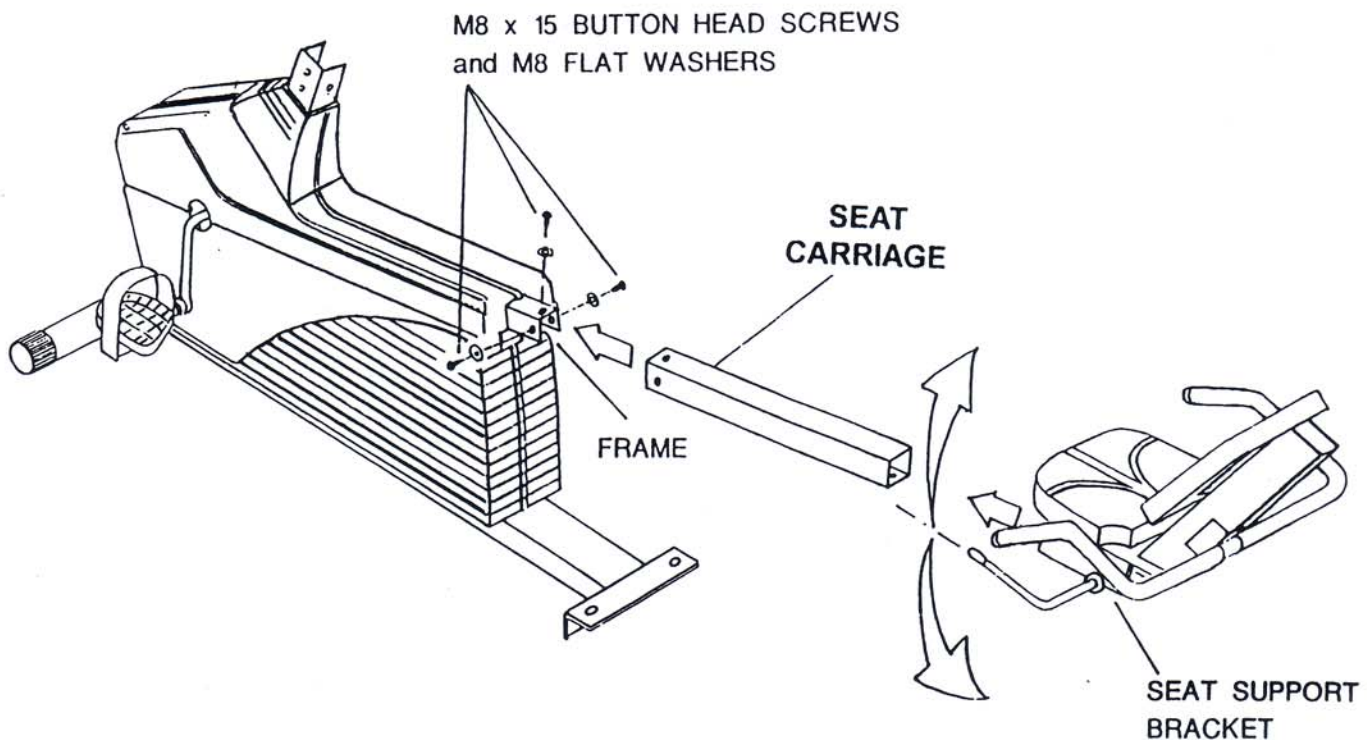
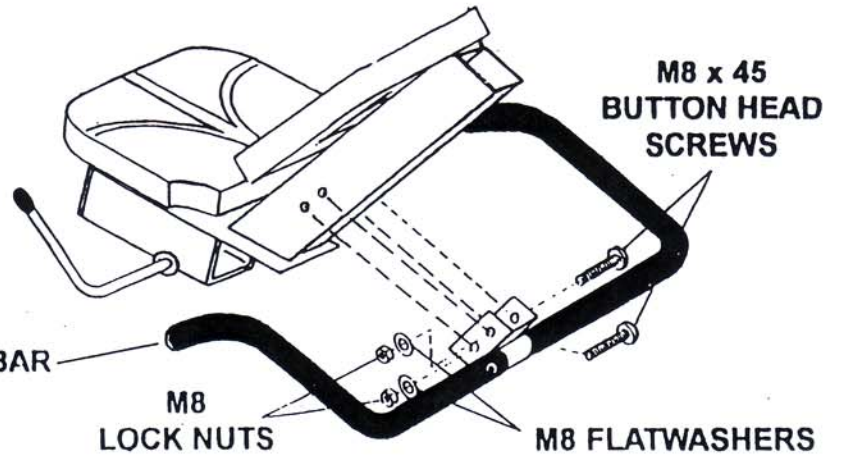

# Assembly Instructions

**A** Fasten REAR SUPPORT TUBE to SEAT CARRIAGE with M8 x 15 BUTTON HEAD SCREW.

**B** Push SQUARE CAP over end of SEAT CARRIAGE.

**C** Insert two M8 x 1.25 x 60 CARRIAGE BOLTS through square holes in REAR FOOT TUBE and FRAME.

**D** Fasten with 8mm WASHERS and M8 x 1.25 CAP NUTS and tighten CAP NUTS.

**E** Push FOOT CAPS over ends of REAR FOOT TUBE.

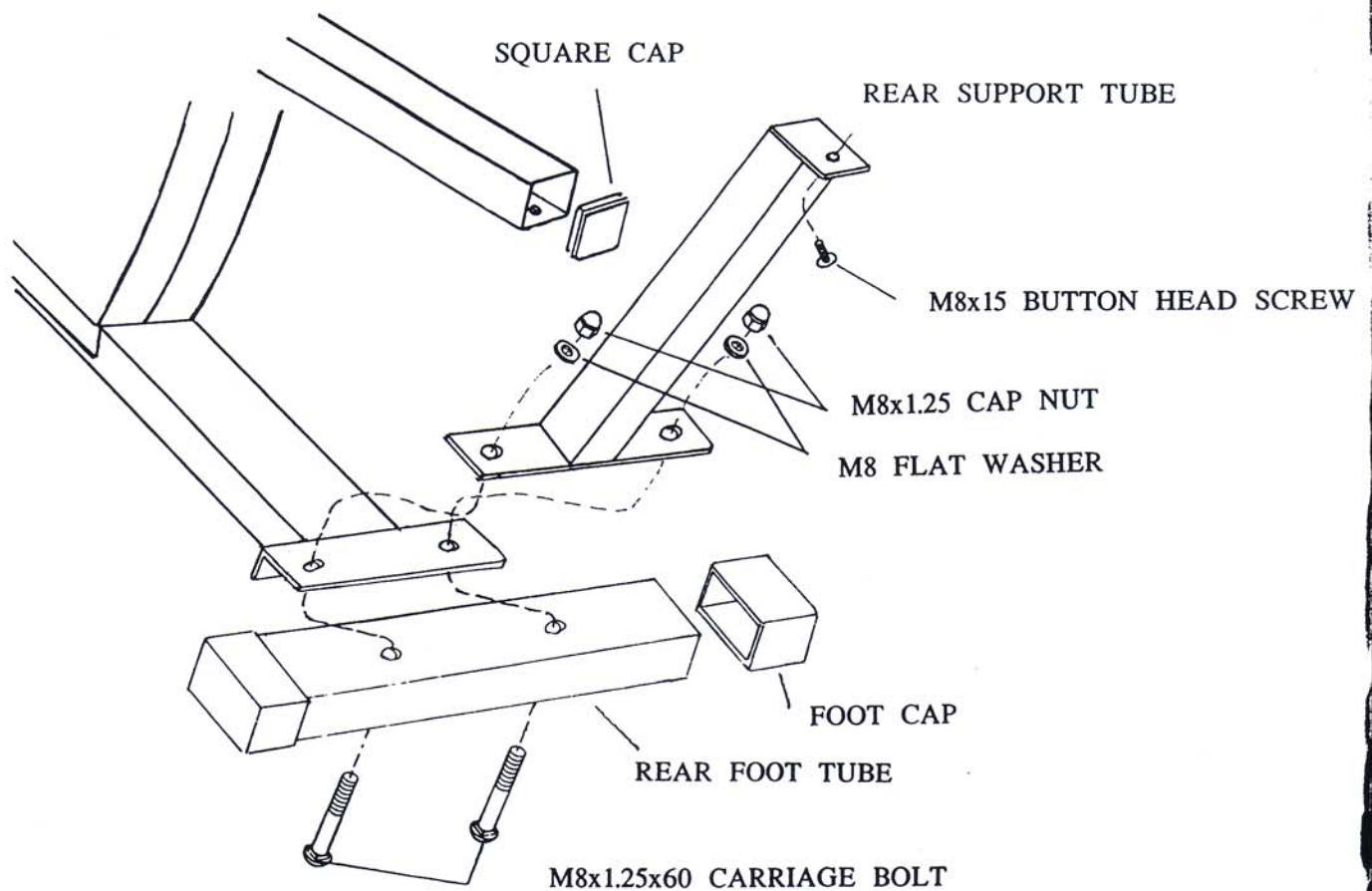

# Assembly Instructions

## Insert BATTERIES.

**NOTE:** Batteries are not included with this unit.

**CAUTION: DO NOT** use rechargeable batteries. Using rechargeable batteries will cause a short circuit and destroy monitor.

- A** Open BATTERY COVER.
- B** Install 4 "D" size BATTERIES. The + and - end of each BATTERY must face in same direction as + and - shown inside case.

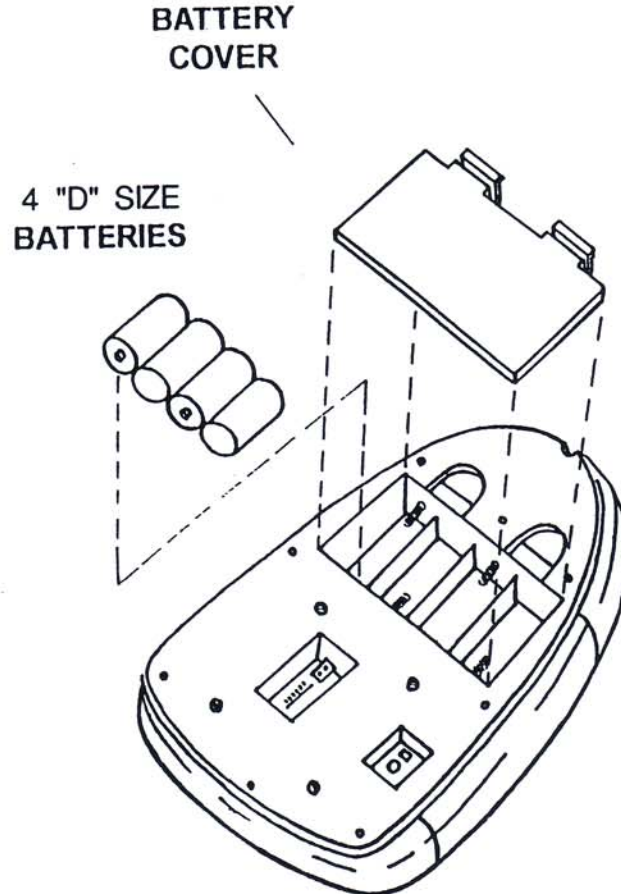

# Assembly Instructions

- A.** Slide the **SLEEVE** onto the **HANDLEBAR**. Push **BALL PLUG** into the end of the **HANDLEBAR**.
- B.** Attach the **HANDLEBAR** to the **CONSOLE TUBE** with **M8X57 BUTTON HEAD SCREWS**, **M8 FLAT WASHERS**, and **M8 LOCKNUTS**.

- C.** Carefully plug **HAND PULSE**, **PICK UP WIRE** and **EXTENSION WIRE** into bottom of **CONSOLE**.
- NOTE:** Make sure wires are correctly attached.
- D.** Fasten **CONSOLE** to **CONSOLE TUBE PLATE** using **M5X20 BUTTON HEAD SCREWS**.
- E.** Fasten **CONSOLE TUBE** to **FRAME** with **M8X15 BUTTON HEAD SCREWS** and **M8 FLAT WASHERS**

**NOTE:** Liquid Soap applied to handlebars will Help Sleeve Slide easier.

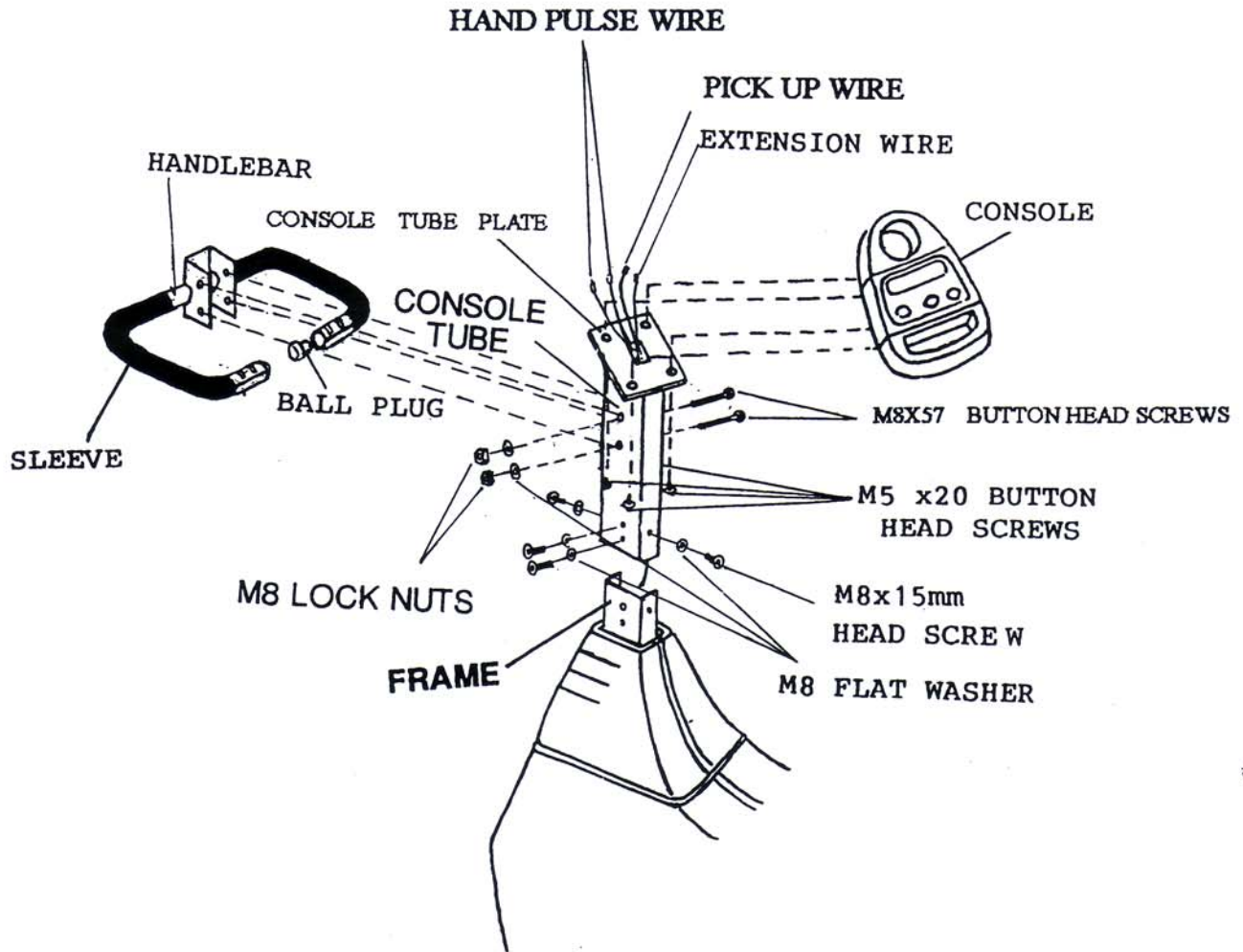



# Operating Instructions

To turn on your monitor, press the ON/OFF button (Step 1) or start to pedal recumbent bicycle and display will automatically turn on.

After turning your monitor on, choose one of the courses PLATEAU, INTERVAL, or MANUAL (Step 2).

After selecting a program choose a resistance level between 1 and 8 by using the + or - arrows (Step 3). Then press ENTER button.

After selecting a resistance level the TIME function will appear in the upper left hand corner of the display. Using the + or - arrows of the TIME function, select between 1-99 minutes. Press ENTER/START and begin workout.

## \* IMPORTANT

1. Make sure the batteries have enough power before using the monitor.
2. Replace the batteries shortly after using the bike for the first few times.



# Console Functions

Your bike is equipped with programmable monitor to help you track your progress and motivate you to reach your fitness goals.

This monitor provides different programs designed to tailor to your fitness goals. Simply choose the program you like, set the time limit and begin exercising-your monitor will then show your pulse, approximate calories burned, elapsed time, speed and distance traveled.

## TIME

- **TIME:** Indicates elapsed time after pressing start in minutes and seconds (0-99 minutes, 0-59 seconds). You can also program your monitor to count down from a set value by using the + and - buttons.

## SPEED

- **SPEED:** Indicates MPH (miles per hour)

## DISTANCE

- **DISTANCE:** Displays the cumulative distance traveled during each workout up to a maximum of 99.9 miles. The distance will be displayed in hundredths of a mile until you reach 10 miles. Then distance will be displayed in tenths of a mile. Example 0.00 - 9.99, then 10.0 - 99.9 miles.

## CALORIES

- **CALORIES:** Your monitor will estimate the cumulative calories burned at any given time during your workout. Calorie expenditure on your monitor is based on realistic expectations; however, your computer is not individually programmable for all necessary variables to accurately monitor actual calories burned.

## LEVEL

- **LEVEL:** Indicates the level of resistance between 1 - 8. The higher the level the more resistance.

## HEART RATE

- **HEART RATE:** Indicates current heart rate in beats per minute during your workout.

# Monitoring Your Heart Rate

Before beginning your workout, check your normal resting heart rate. Place your fingers lightly against your neck, or against your wrist over main artery. After finding your pulse, count the number of beats for 10 seconds. Multiply the number of beats by six to determine your pulse rate per minute. A chart is provided for you to log your heart rate at rest; after warming up, during your workout, and two minutes during your cool down, then 10 minutes after your cool down. We recommend taking your heart rate at these times to accurately track your progress as it relates to better physical fitness.

Your maximum heart rate and aerobic capacity naturally decreases as you age. In general, to determine your maximum heart rate, subtract your age from 220. This may vary from one person to another, but use this number to find your approximate effective target zone.

(MHR) = Maximum Heart Rate

(THR) = Target Heart Rate

$220 - \text{age} = \text{maximum heart rate (MHR)}$ .  $\text{MHR} \times .70 = 70\%$  of your heart rate.

$\text{MHR} \times .85 = 85\%$  of your maximum heart rate.

For example, if you are 30 years old, your calculations will be as follows:

$$220 - 30 = 190$$

$$190 \times .70 = 133 \text{ (low end or 70\% of THR)}$$

$$190 \times .85 = 161 \text{ (High end or 85\% of THR)}$$

See Table No 1 on next page for additional calculations.

If exercise is new to you, don't push yourself too fast. Be conscious of your body and what it is telling you. If pain develops anywhere in your body, slow down. Heart rhythm disturbances may occur if you stop abruptly, so always remember to cool down.

You are an individual and your body is unique. All of the information in this manual is for an average person with average physical fitness. Use these instructions as a guide.

# HEART RATE TARGET ZONE FOR CARDIOVASCULAR FITNESS

**TABLE 1**

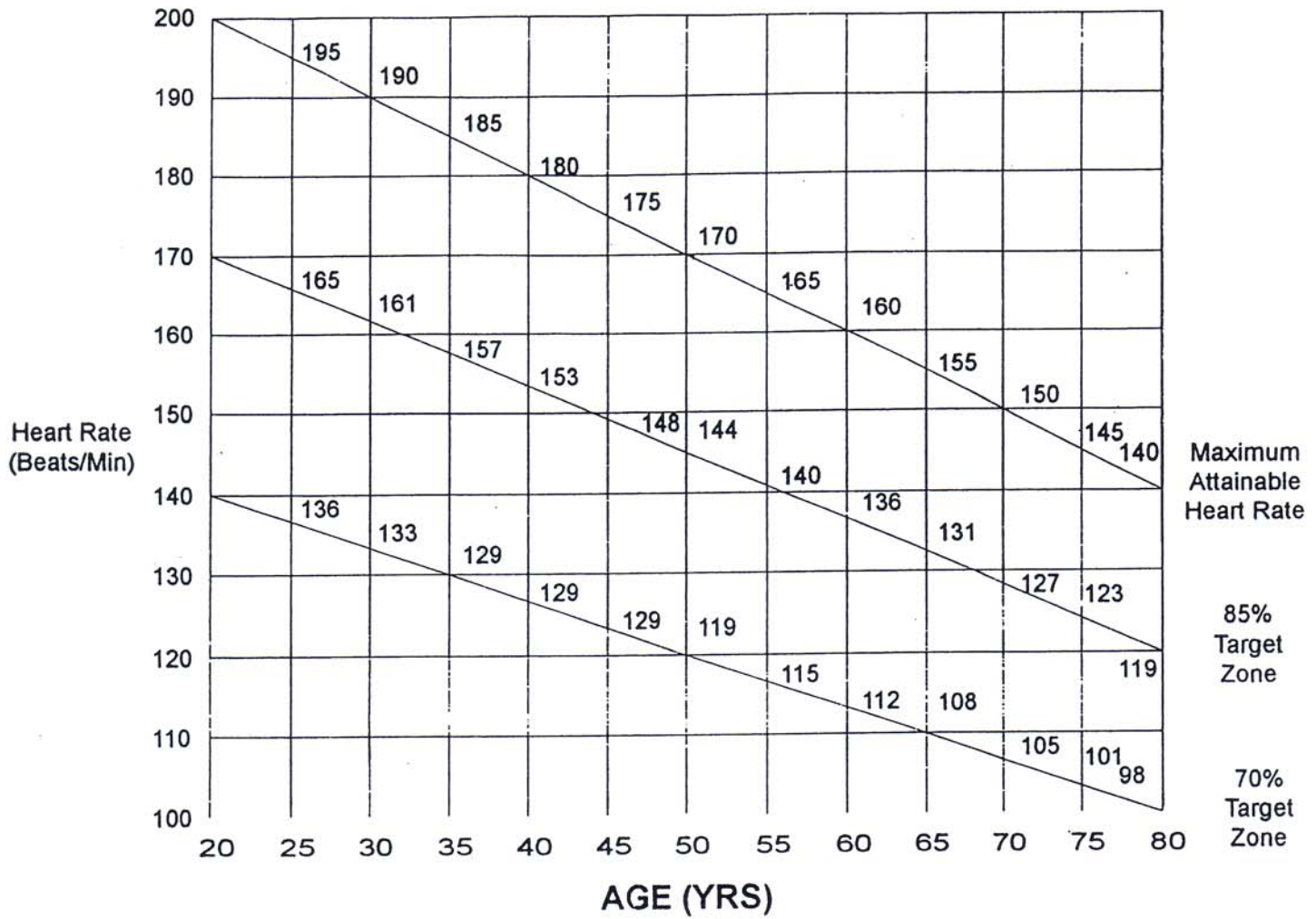

**TABLE 2**

Exercise Week	Warm Up Period	THR% Minutes	Cool Down Period	Total Time	Sessions Per Wk.	Total Time Per Wk.
1 & 2	4	60-65% -8	5	17	3	51
3 & 4	5	65-70% -10	5	20	3	60
5 & 6	5	70-75% -15	5	25	3	75
7 & 8	5	70-80% -20	5	30	3	90
9 & 10	5	70-85% -25	5	35	3	105
11 & 12	5	70-85% -25	5	35	3	105

# Exercise Guide

## WARNING!

Before using this recumbent bicycle or starting any exercise program, consult your physician. This is especially important for persons over the age of 35 and/or persons with pre-existing health problems. Keys Fitness Products LP assumes no responsibility for personal injury or property damage sustained by or through the use of this product.

### WARM UP

Warming up prepares the body for exercise by increasing circulation, supplying more oxygen to the muscles and raising body temperature. Begin each workout with 5 to 10 minutes of stretching and light exercise to warm up. The drawings on this page show several forms of basic stretching you may perform before your workouts. Again, consult a physician before starting this or any other exercise program!

- 1) **Toe Touch Stretch (Repeat 3 times).** Stand bending your knees slightly and slowly bend forward from your hips. Allow your back and shoulders to relax as you reach down toward your toes as far as possible. Hold for 15 counts, then relax. This will stretch your hamstrings, back of knees, and back.
- 2) **Hamstring Stretch (Repeat 3 times).** Sit with one leg extended. Bring the sole of the opposite foot toward you and rest it against the inner thigh of your extended leg. Reach toward your toes as far as possible. Hold for 15 counts, then relax. Repeat with the other leg. This will stretch your hamstrings, lower back, and groin.
- 3) **Calf/Achilles Stretch (Repeat 3 times).** With one leg in front of the other, reach forward and place your hands against a wall. Keep your back leg straight and your back foot flat on the floor. Bend your front leg, lean forward and move your hips toward the wall. Hold for 15 counts, then relax. To cause further stretching of the Achilles tendons, bend your back leg as well. Repeat with the other leg. This will stretch your calves, Achilles tendons, and ankles.
- 4) **Quadriceps Stretch (Repeat 3 times).** With one hand against a wall for balance, reach back and grasp one foot with your other hand. Bring your heel as close to your buttocks as possible. Hold for 15 counts, then relax. Repeat with the other leg. This will stretch your quadriceps and hip muscles.
- 5) **Inner Thigh Stretch (Repeat 3 times).** Sit with the soles of your feet together and your knees outward. Pull your feet toward your groin area as far as possible. Hold for 15 counts, then relax. This will stretch your quadriceps and hip muscles.

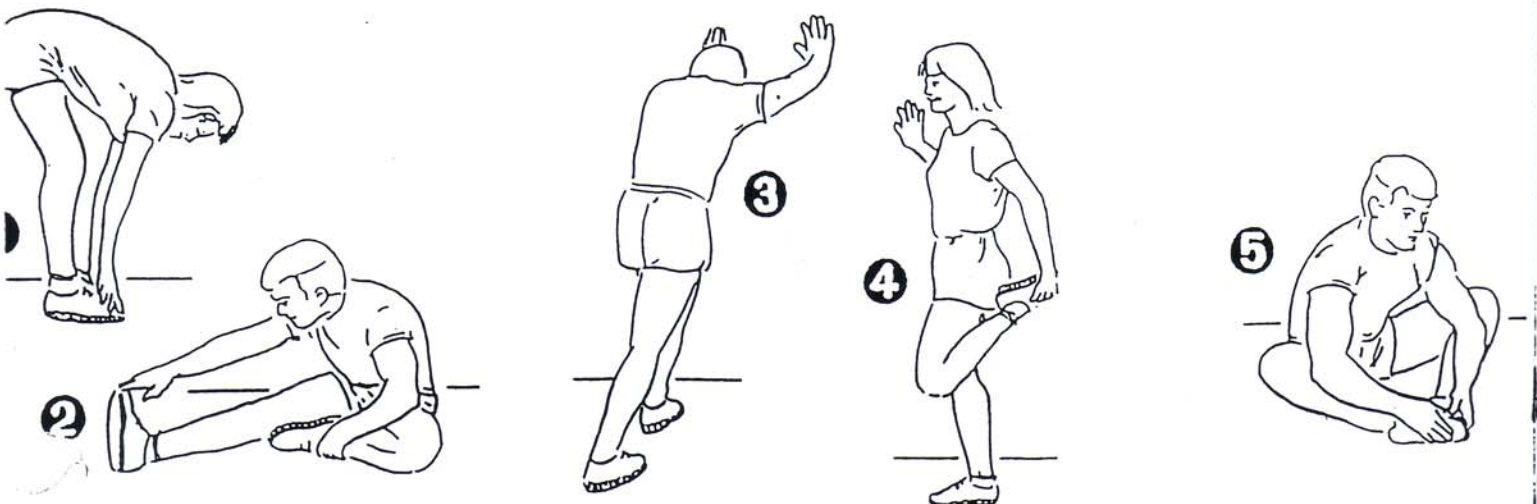

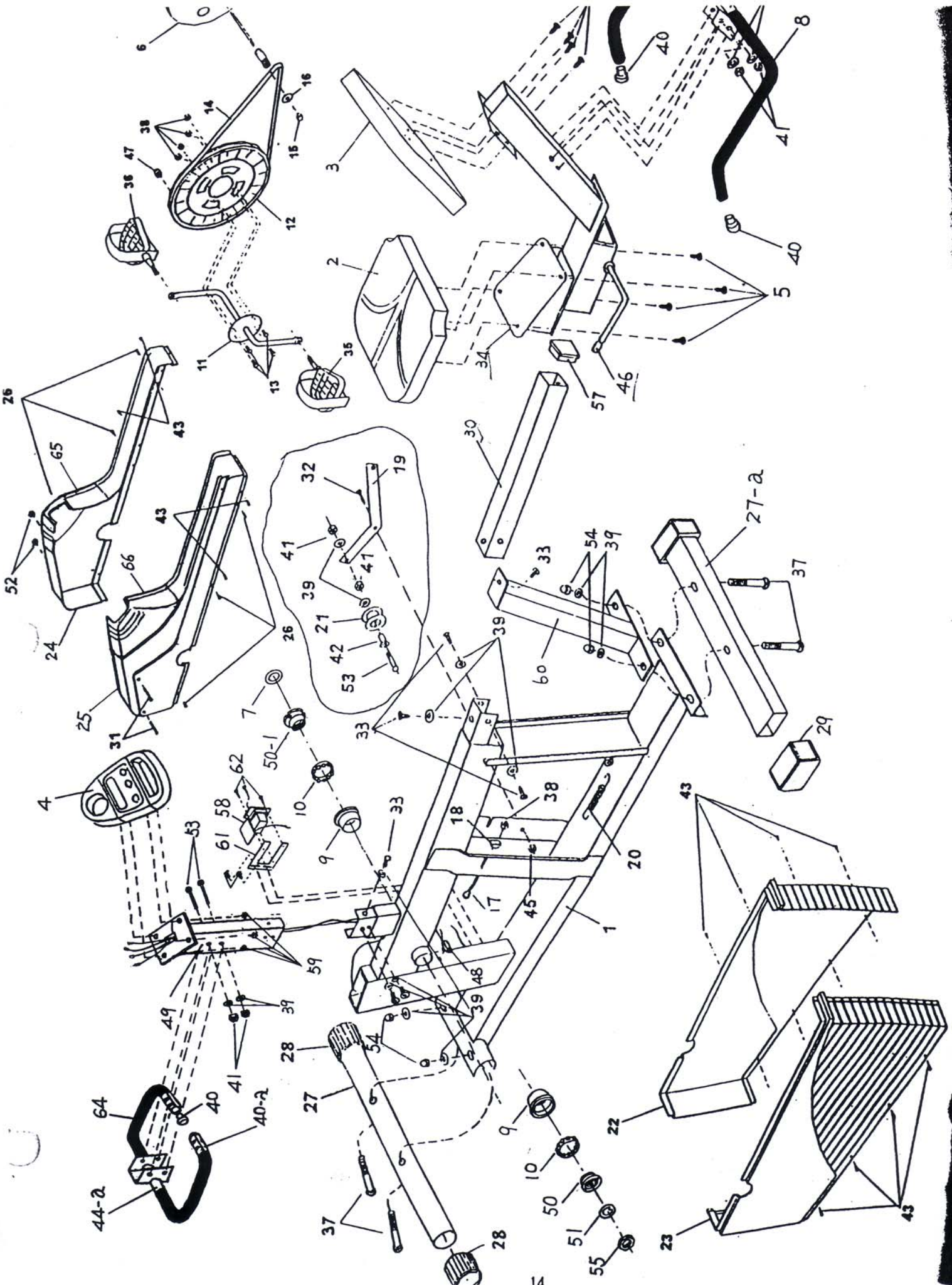

ATTN: BRUCE

**PARTS LIST**

NO.	DESCRIPTION	Q'TY	NO.	DESCRIPTION
1	Frame	1	34	Seat Support Bracket
2	Seat Cushion	1	35	Left Pedal
3	Back Cushion	1	36	Right Pedal
4	Monitor	1	37	M8x1.25x60mm Carriage
5	M6x1x12 Long Allen Head Screw	8	38	M6x1 Nut
6	Mag Brake	1	39	M8 Flat Washer
7	Crank Washer	1	40	1" Ball Plug
8	Sleeve	2	40-a	Hand Pulse
9	Bearing Cup	2	41	M8 Locknut
10	Bearing	2	42	Idler Bushing
11	Crank	1	43	M4x16mm Sheet Metal S
12	Pulley	1	44	Seat Handlebar
13	M6x1x10mm Machine Screw	4	44-a	Handlebar
14	"V" Belt	1	45	M6x1 Locknut
15	M10x1 Cap Nut	2	46	Cam Lock
16	10mm IDx22mm OD Washer	2	47	Magnet
17	Eyebolt	2	48	Reed Switch
18	Adjustment Channel	2	49	Console Tube
19	Belt Tension Bracket	1	50	Notched Bearing Nut
20	Spring	1	50-1	Slotted Bearing Nut
21	Idler Pulley	1	51	Crank Washer
22	Bottom Right Cover	1	52	M5x8 Hex Nut
23	Bottom Left Cover	1	53	M8x45mm Button Head S
24	Top Right Cover	1	54	M8x1.25 Cap Nut
25	Top Left Cover	1	55	Crank Nut
26	M4x12mm Sheet Metal Screw	6	56	Owner's Manual
27	Front Foot Tube	1	57	2" Square Cap
27-a	Rear Foot Tube	1	58	Gear Box
28	Wheel	2	59	M5x20 Button Head Scre
29	Foot Cap	2	60	Rear Support Tube
30	Seat Carriage	1	61	Gear Box Plate
31	M5x8x70 Screw	2	62	M3.5x15mm Sheet Metal
32	M6x1x20 Screw	1	63	M8x57mm Button Head S
33	M8x15 Button Head Screw	7	64	Sleeve
			65	Connecting Right Cover
			66	Connecting Left Cover

★

★

★

★

*[Large scribbled-out area with faint handwritten text]*

CM



## QUESTIONS?

CALL OUR TOLL FREE  
HELPLINE

USA: (888) 340-0482

or  
(214) 340-8888

Canada: (800) 897-6025

### CAUTION!

Please read the precautions and instructions in this manual before using this equipment. Please save this manual for future reference.

Dear Keys' Recumbent Bicycle Customer!

Thank you for purchasing a Keys' recumbent bicycle! You have now invested in a superior quality product and a fitness lifestyle. We here at Keys Fitness Products have produced what we believe is the finest recumbent bicycle with exceptional value.

Should you ever have a question concerning your recumbent bicycle, please feel free to give us a call at 1-888-340-0482. We will be glad to be at your service.

Sincerely yours in fitness!

Keys Fitness Products, LP

# OWNER'S MANUAL

**KEYS FITNESS PRODUCTS, L.P.**  
**PO Box 551239**  
**Dallas, Texas 75355-1239**

**MADE IN TAIWAN**