



Safety Interlocking Switch GS (Non-contact) Instruction Manual



Detailed information and use of the GS (Non-contact) is also described in the "GS (Non-contact) User's manual". In order to acquire the "GS (Non-contact) User's manual", download it from the KEYENCE website or call the nearest KEYENCE office.
 <KEYENCE website> www.keyence.com/global.jsp

This manual explains items such as the handling, operation, and precautions for the Safety Interlocking Switch GS (Non-contact). Read this manual carefully and thoroughly understand its contents to use the GS (Non-contact) to the full extent of its capabilities.

Also, keep this manual in a safe place for future reference. Ensure that the end user of this product receives this manual.

This manual is the original instruction manual.

Symbols

	It indicates a hazardous situation which, if not avoided, will result in death or serious injury.
	It indicates a situation which, if not avoided, could result in product damage as well as property damage.
	It indicates cautions and limitations that must be followed during operation.
	It indicates additional information on proper operation.
	It indicates tips for better understanding or useful information.

Safety Precautions

General precautions

	<ul style="list-style-type: none"> KEYENCE does not guarantee the function or performance of the GS (Non-contact) if it is used in a manner that differs from the GS (Non-contact) specifications contained in this manual or if the GS (Non-contact) is modified by the customer. The GS (Non-contact) can only be used in combination with dedicated actuators. It cannot be used in combination with other actuators or similar devices. Do not bypass the GS (Non-contact), remove it or change its installation orientation after installation. Do not use a replacement actuator to bypass the GS (Non-contact). Store replacement actuators strictly to prevent their easy access. When using the GS (Non-contact) to protect machine operators against a hazard or hazardous zone or when using the GS (Non-contact) as a safety component for any purpose, always follow the applicable requirements of the laws, rules, regulations and standards in the country or region where the GS (Non-contact) is used. For such regulations, you should directly contact the regulatory agency responsible for occupational safety and health in your country or region. Depending on the type of machine on which the GS (Non-contact) is installed, there may be special safety regulations related to the use, installation, maintenance, and operation of the safety component. In such a case, you must fulfill such safety regulations. The responsible personnel must install the GS (Non-contact) in strict compliance with such safety regulations. The responsible personnel must do the training to the assigned personnel for the correct use, installation, maintenance, and operation of the GS (Non-contact). The user of the machine must receive specialized training related to the GS (Non-contact), and must then understand and adhere to the safety restrictions, laws, and regulations in the country or area in which the GS (Non-contact) is being used. If the GS (Non-contact) does not operate correctly, the user of the machine must report this information to the party responsible for the use of the GS (Non-contact) and immediately stop the machine.
--	--

	<ul style="list-style-type: none"> The GS (Non-contact) is designed with the assumption that it would be correctly installed in accordance with the installation procedures described in this manual and correctly operated according to the instructions in this manual. You must perform an appropriate installation of the GS (Non-contact) after performing a sufficient risk assessment for the target machine. Be sure to absolutely confirm that there is nobody in the hazardous zone, before you remove the GS (Non-contact) from the machine for replacement or disposal.
--	---

	<ul style="list-style-type: none"> When disposing of the GS (Non-contact), always follow the applicable requirements of the laws, rules, regulations and standards in the country or region where the GS (Non-contact) is used. Dispose of this product as industrial waste.
--	--

Environment of use

	<ul style="list-style-type: none"> Do not use the GS (Non-contact) in an environment (temperature, humidity, interfering light, etc.) that does not conform to the specifications contained in this manual. Do not use a device that emits strong electromagnetic waves near the GS (Non-contact). This product is not intended for use as an explosion-proof product. Do not use this product in a hazardous location and/or potentially explosive atmosphere. Do not use the GS (Non-contact) in the presence of substances, such as heavy smoke, particulate matter, or corrosive chemical agents, that may induce deterioration in product quality. Be sure to absolutely confirm that there is nobody in the hazardous zone, before the interlock is released (i.e. the machine system restarts) by the interlock reset mechanism. Indoor use only.
--	--

Target machines for installation

	<ul style="list-style-type: none"> It must be possible to perform an emergency stop on the machine to which the GS (Non-contact) is installed at any and all operation points during the operation cycle. Also, do not use the GS (Non-contact) on machines that have irregular stop times. Do not use the GS (Non-contact) to control (stop forward motion, etc.) trains, cars and other transportation vehicles, aircraft, equipment for use in space, medical devices, or nuclear power generation systems.
--	--

Circuit design and wiring

	<ul style="list-style-type: none"> Be sure to turn the power supply off before performing electrical wiring. Perform electrical wiring according to the electrical conventions, restrictions, standards, and laws in the country or area in which the GS (Non-contact) will be used. Use cables with length less than or equal to the specification in this manual. Usage of cables longer than the specified value may cause the improper operation of safety functions and may cause a dangerous situation.
--	--

Precautions on Regulations and Standards

CE Marking

KEYENCE Corporation has confirmed that this product complies with the essential requirements of the applicable EU Directive(s), based on the following specifications. Be sure to consider the following specifications when using this product in the Member States of European Union.

- Machinery Directive
- RE Directive

The GS (Non-contact) is a safety component defined in the EU Machinery Directive Annex V and has been certified by TÜV SÜD Product Service GmbH. The GS (Non-contact) complies with the following EN Standards.

- EN 61508
- EN 62061
- EN ISO13849-1
- EN ISO14119
- EN 60947-5-3
- EN300 330

The full text of the EU declaration of conformity is available at the following internet address: <http://www.keyence.com/cedoc>

- Frequency band of operation 123kHz
- Maximum radio-frequency power 60 dBµV/m

These specifications do not give any guarantee that the end-product with this product incorporated complies with the essential requirements of RE and Machinery Directive. The manufacturer of the end-product is solely responsible for the compliance on the end-product itself according to these Directives.

CSA Certificate and North American Regulations

The GS (Non-contact) complies with the following UL and CSA standards and regulations, and has received CSA certification.

Applicable standards:

- CAN/CSA C22.2 No. 61010-1
- UL61010-1

Be sure to consider the following specifications when using this product as a product certified by CSA.

- Overvoltage category II
- Pollution degree 3.
- Install this product at the altitude of 2000 m or less.
- Indoor use only.
- When using this product, use the following power supply. CSA or UL certified power supply that provides Class 2 output as defined in the CEC (Canadian Electrical Code) and NEC (National Electrical Code)

Applicable standard:

- FCC Part15 Subpart B, Class A Digital Device
- FCC Part15 Subpart C
- ICES-003, Class A Digital Apparatus
- RSS-210

This device complies with part 15 of FCC Rules and Innovation, Science and Economic Development Canada's licence-exempt RSSs. Operation is subject to the following two conditions: (1) this device may not cause harmful interference, and (2) this device must accept any interference received, including interference that may cause undesired operation.

Le présent appareil est conforme à la partie 15 des règles de la FCC et aux normes des CNR d'Innovation, Sciences et Développement économique Canada applicables aux appareils radio exempts de licence. L'exploitation est autorisée aux deux conditions suivantes : (1) l'appareil ne doit pas produire de brouillage, et (2) l'appareil doit accepter tout brouillage subi, même si le brouillage est susceptible d'en compromettre le fonctionnement.

FCC CAUTION

Changes or modifications not expressly approved by the party responsible for compliance could void the user's authority to operate the equipment.

Note: This equipment has been tested and found to comply with the limits for a Class A digital device, pursuant to part 15 of the FCC Rules. These limits are designed to provide reasonable protection against harmful interference when the equipment is operated in a commercial environment. This equipment generates, uses, and can radiate radio frequency energy and, if not installed and used in accordance with the instruction manual, may cause harmful interference to radio communications. Operation of this equipment in a residential area is likely to cause harmful interference in which case the user will be required to correct the interference at his own expense.

Chapter 1 Before Operation

1-1 Overview and Configuration

The GS (Non-contact) is a Type4 Interlocking Device without guard lock based on ISO14119.

Coding level: Low or high (switchable)

📖 "4-6 Coding Level" (page 6)

By combining the GS (Non-contact) with a door or similar movable safety guard and with a safety-related control system, it is possible to stop hazardous machine operations if the door or similar part opens during hazardous machine operations.

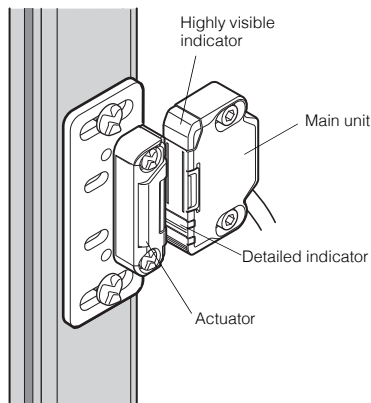

Reference

The GS (Non-contact) can also be used for other purposes such as protecting manufacturing processes.

1-2 Product List

■ Main unit

For details on the main unit models, see 📖 "5-1 Model Number Description" (page 7).

■ M12 connector type cables

● Standard cables

Use this cable in combination with a main unit (connector type), Y-shaped connector, or extension cable.

Type	Model	Number of pins	Length
Simple function	GS-P5C5	5	5 m
	GS-P5C10		10 m
Standard	GS-P8C5	8	5 m
	GS-P8C10		10 m
Advanced function	GS-P12C5	12	5 m
	GS-P12C10		10 m
	GS-P12C20		20 m

● Extension cables

Type	Model	Number of pins	Length
Simple function	GS-P5CC5	5	5 m
	GS-P5CC10		10 m
Standard	GS-P8CC1	8	1 m
	GS-P8CC5		5 m
	GS-P8CC10		10 m

■ Mounting brackets

- GS-B01
- GS-B11

■ Optional parts

● Y-shaped connector

GS-Y01

● End connector

GS-Y02

● Replacement actuator

GS-A01

1-3 Package Contents

■ Main unit

- Sensor (main unit)
- Actuator
- Instruction Manual

Chapter 2 Installation

2-1 Installation Conditions

Note the following items before installation.

■ The effect of surrounding metal

⚠ DANGER The sensor's operating distance may be affected by the presence of metal in the surrounding area. After installation, check that an appropriate safety distance based on the detecting distance is used.

■ Sensor and actuator orientation

Correct installation orientations

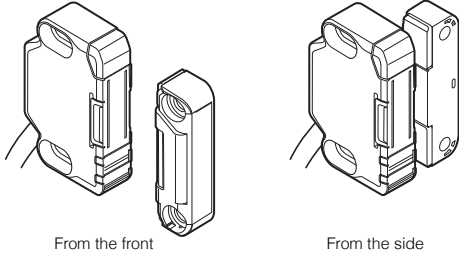

Incorrect installation orientations

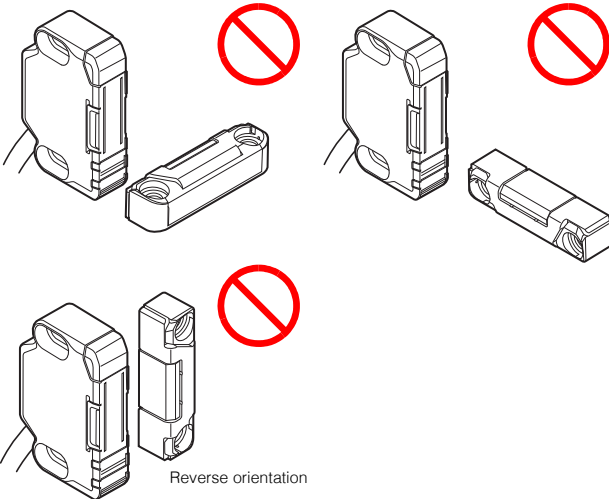

■ Operating area

ON area

Front installation

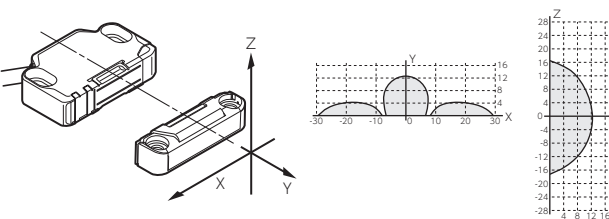

Side installation

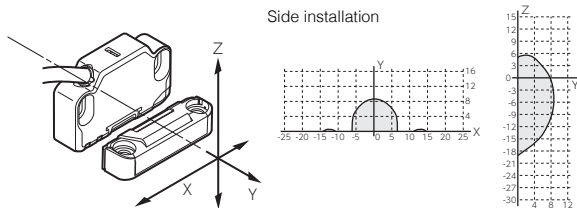

⚠ DANGER

- The above values indicate the recommended distance. Check whether there are issues in the actual installation environment.
- When installing the unit on a sliding door, do so at a distance of 6 mm or more to prevent the effect of the side lobe.

■ Mutual interference

When using multiple GS (Non-contact) units in close proximity, they may malfunction due to mutual interference. To prevent mutual interference, install the GS (Non-contact) units as shown below.

Distance between sensors

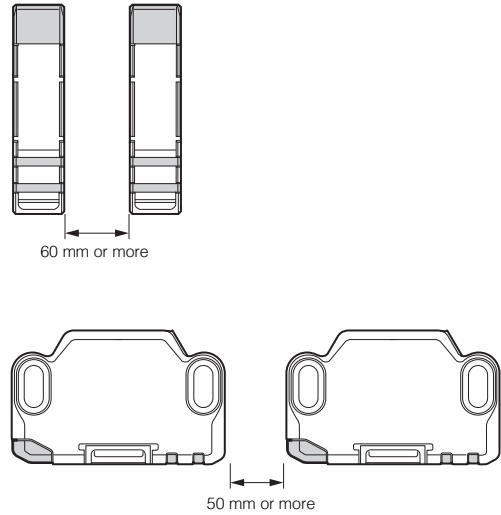

Distance between actuators

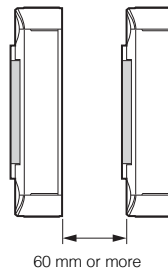

2-2 Installation Method

■ Installing the unit to a hinged door

1

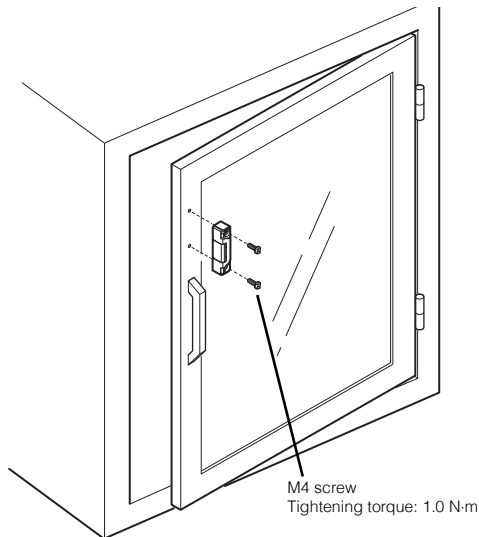

2

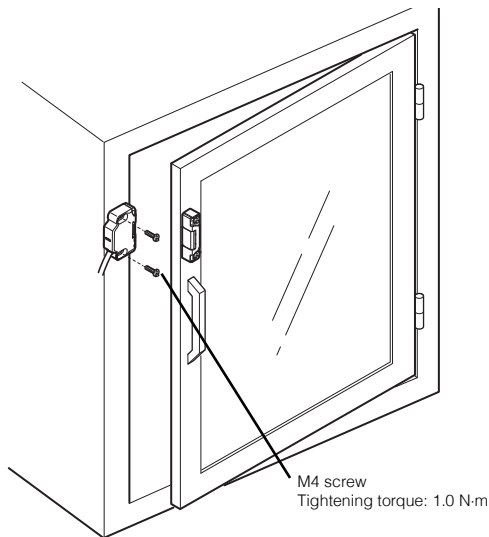

- To minimize defeat possibilities, GS (Non-contact) should be installed in a position where the accessibility to GS (Non-contact) is prevented (e.g. mounting out of reach, physical obstruction or shielding or mounting in hidden position), otherwise use non-detachable fixing to prevent dismantling or de-positioning of GS (Non-contact) (e.g. Using a flat head screw and plugging the slot on the screw head with a high-strength threadlocker after tightening the screw or other equivalent fixing system). Refer ISO 14119 for more information to minimize defeat possibilities.
- Securely tighten the screws for the sensor, actuator, and mounting brackets according to the specified tightening torque.
- To prevent self-loosening, use screw locker on the screws fixing the GS (Non-contact).

⚠ DANGER

Reference

- When replacing the sensor or actuator, do so by following the same procedure.
- The appropriate screws must be purchased separately.

2-3 Cascade Connection Between Units

Multiple GS (Non-contact) and GS (Lock) units can be connected in series (in a cascade connection).

This makes it possible to monitor the opening and closing of multiple doors or similar items on the same machine.

For the wiring method, see "Cascade connection wiring example" (page 5).

Chapter 3 Wiring

3-1 Power Supply

If the power supply for the GS (Non-contact) is the converting type, the power supply for the GS (Non-contact) must meet the conditions listed below in order to meet the requirements specified in ISO 14119, IEC 60947-5-3, UL 61010-1, and CAN/CSA-C22.2 No. 61010-1.

- The rated output voltage is within 24 V DC $\pm 20\%$ (Ripple P-P 10 % or less, Class2, SELV, Overvoltage category II).
- The insulation between the primary and secondary circuits is reinforced or double insulation.
- The power supply complies with the laws, regulations, and standards related to items such as electrical safety and electromagnetic compatibility (EMC) in the country or area in which the GS (Non-contact) will be used.

▶ Important

When the power supply used with the GS (Non-contact) is shared with other machines or electrical products, the voltage supplied to the GS (Non-contact) may drop due to temporary increases in the current consumption of these other machines and the GS (Non-contact) may also be affected by the noise generated by these other machines. Errors or other such problems may occur with the GS (Non-contact) in this situation, so it is strongly recommended to avoid sharing the power supply of the GS (Non-contact) with other machines or electrical products.

3-2 Cable Wire Colors and Functions

Simple function type (M12 connector, 5 pins)

Pin number	Wire color	Function
1	Brown	+24 V
2	White	OSSD2
3	Blue	0 V
4	Black	OSSD1
5	Gray	AUX output1

Standard type (loose wires or M12 connector, 8 pins)

Pin number	Wire color	Function
1	Gray	AUX output1
2	Brown	+24 V
3	Light blue	Not used
4	Red/white	Safety input 2
5	Black	OSSD1
6	White	OSSD2
7	Blue	0 V
8	Red/black	Safety input 1

Advanced function type (loose wires or M12 connector, 12 pins)

Pin number	Wire color	Function
1	Brown	+24 V
2	Red/black	Safety input 1
3	Blue	0 V
4	Black	OSSD1
5	Gray	AUX output 1
6	Red/white	Safety input 2
7	White	OSSD2
8	Pink	Interlock/EDM selection input
9	Gray/black ^{*1}	Not used
10	Light blue ^{*1}	Not used
11	Yellow	Reset/EDM input
12	Light blue/black ^{*1}	Not used

*1 This is not present on loose wire types.

■ Pin layout (sensor main unit, M12 connector type)

Simple function (M12, 5 pins, male)

Standard type (M12, 8 pins, male)

Advanced function type (M12, 12 pins, male)

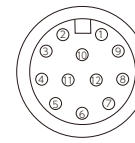
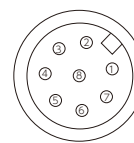
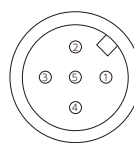

3-3 Wiring Example

■ Cascade connection wiring example

Wire the safety inputs of a GS (Non-contact) to the OSSDs of the next GS (Non-contact) to implement a cascade connection.

- “4-1 OSSD” (page 5)
- “4-2 Safety Input” (page 6)

1st unit
GS (Non-contact)
PNP output
Advanced function type
Interlock: Manual
EDM: Use
Cascade connection: Yes

2nd unit
GS (Non-contact)
PNP output
Advanced function type
Interlock: Automatic
EDM: Do not use
Cascade connection: No

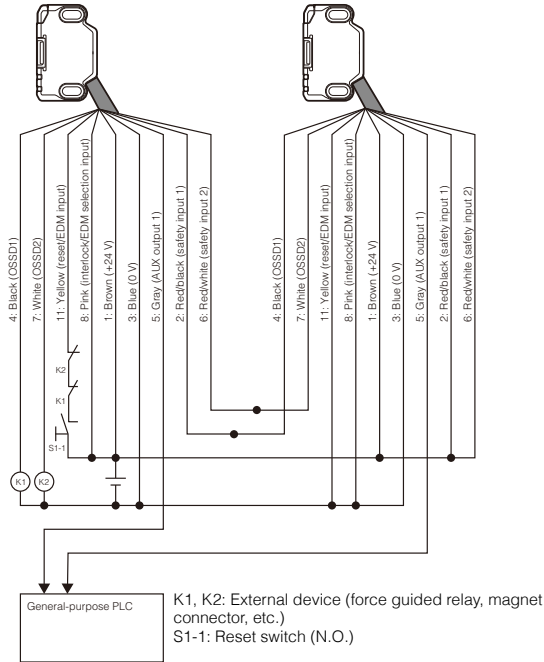

■ Cable length and number of connected units (Standard)

A: Maximum cable length	30.3 m
B: Maximum number of connected units	30

Contact KEYENCE for the maximum number of connected units when using a cascade connection that also includes GS (Lock) units.

3-4 I/O Circuit Diagrams

Output circuit (PNP type)

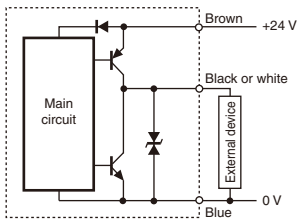

Output circuit (NPN type)

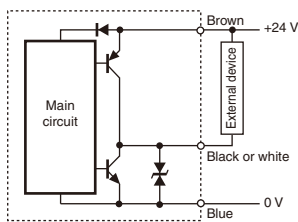

Input circuit (PNP type)

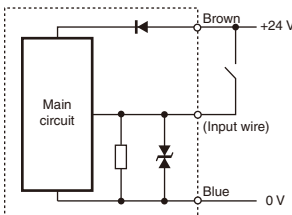

Input circuit (NPN type)

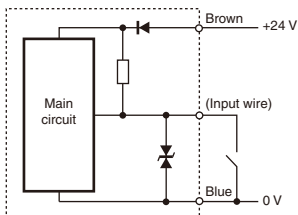

AUX output circuit (PNP/NPN common)

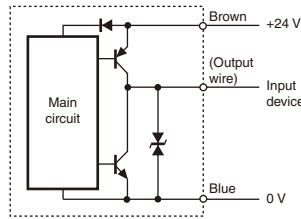

Chapter 4 Functions

The functions that can be used with the GS (Non-contact) vary depending on the model of the main unit (simple function type/standard type/advanced function type).

	Simple function type	Standard type	Advanced function type
Number of pins	5	8	12 (*1)
OSSD	✓	✓	✓
Safety input		✓	✓
Interlock function			✓
EDM function			✓
Number of AUX outputs	1	1	1
Coding level switching	✓	✓	✓

*1 The loose wire type has nine cores.

4-1 OSSD

An OSSD output is a safety output for the safety-related part of a machine control system.

OSSD 1/2 is a pair of safety outputs that are redundant.

The GS (Non-contact) generates self-diagnosis signals on its internal control circuit to perform diagnostics on the OSSD. These signals periodically force the OSSD into a temporary OFF-state when the OSSD is in the ON-state.

If the internal control circuit receives a feed-back signal (OFF-signal) based on the self-diagnosis, the GS (Non-contact) determines that its OSSD is operating normally. If the OFF-signal is not returned to the internal control circuit, the GS (Non-contact) determines that there is a problem with the OSSD or wiring and goes to an error state.

■ OSSD operation

The OSSDs go to OFF state:

- During startup, in the error state, when switching the coding level

When all the conditions shown below are met during normal operation, the OSSDs go to ON state. (*1)

- The sensor has detected an actuator.
- Safety inputs are ON.

*1: The OSSDs go to OFF state in the interlock reset ready state.

• For the wiring to a safety-related machine control system, the output of both OSSD 1 and OSSD 2 must be used by the safety-related machine control system in order to create a safety system.

• If only one OSSD output is used to construct the machine's control system, an OSSD malfunction will make it impossible to stop the machine, which may lead to extremely dangerous situations including serious injury to or death of the machine's user.

• When using a PNP sensor, do not cause a short-circuit between the OSSD and +24V. Otherwise, the OSSDs will stay in the ON-state and it will cause a dangerous situation.

• When using an NPN sensor, be sure to connect the load between the OSSD and 0 V. Connecting this between the OSSD and +24 V by mistake will invert the OSSD operation from its normal behavior, which is extremely dangerous.

• When using an NPN sensor, do not cause a short-circuit between the OSSDs and 0V. Otherwise, the OSSDs stay in the ON-state and it will cause a dangerous situation.

• When using an NPN sensor, be sure to connect the load between the OSSD and +24 V. Connecting this between the OSSD and 0 V by mistake will invert the OSSD operation from its normal behavior, which is extremely dangerous.

• To prevent malfunctions caused by ground faults on the OSSD output wire, perform wiring in a manner such that the requirements specified in paragraph 9.4.3 of IEC 60204-1 are met.

4-2 Safety Input Standard type Advanced function type

This function controls the OSSDs of the GS (Non-contact) with input signals from sensors or similar devices connected to the safety inputs. Safety input 1 and safety input 2 form a safety input pair. If safety input 1 or safety input 2 turns OFF, the OSSDs turn OFF. Multiple GS units can be connected and used in an expanded system (with a cascade connection) by connecting the OSSDs of a different GS (Non-contact) or GS (Lock) to the safety inputs. The system can be expanded to include up to thirty units in the case of the GS (Non-contact).

Point The simple function type has no safety input.

- Reference**
- Wire the safety inputs as shown below when they are not in use. PNP type: Short circuit to 24 V. NPN type: Short circuit to 0 V.
 - If safety input 1 and safety input 2 are mismatched for 3 seconds or more a Safety Input Error will occur.

Emergency stop switch/button wiring

Wiring an emergency stop switch/button to the safety inputs makes it possible to perform an emergency stop on the machine by pressing the emergency stop switch/button.

DANGER

- Use an emergency stop switch/button that has two or more independent, NC (normally closed) contacts. For the requirements related to emergency stop switches, see IEC 60204-1, ISO 13850, and all other requirements, regulations, standards, and laws related to occupational safety and health in the country or area where the GS (Non-contact) will be used. For such regulations, you should directly contact the regulatory agency responsible for occupational safety and health in your country or region.
- Ensure that the device does not start or restart automatically when the emergency stop switch/button is reset.
- Only the devices shown below can be connected to the safety inputs. Do not connect any other devices.
 - GS (Non-contact) OSSDs, GS (Non-contact) OSSDs, and emergency stop switch/button
- When using a PNP sensor, please connect the OSSDs of the PNP type GS (Lock) or GS (Non-contact) to the safety inputs.
- When using a NPN sensor, please connect the OSSDs of the NPN type GS (Lock) or GS (Non-contact) to the safety inputs.

4-3 Interlock Function Advanced function type

Interlock is a function that prevents the OSSDs from automatically going into the ON-state from the OFF-state. This prevents the unintended start-up and/or the unintended restart of the machine if the interlock is applied to the GS (Non-contact). It is necessary to perform the reset operation in order for the GS (Non-contact) to go back to normal operation from the interlock condition.

Point The interlock function cannot be set on the simple function type and standard type. The interlock function is fixed to Automatic.

On the advanced function type, the interlock function setting can be selected from two types: Automatic and Manual.

Automatic and Manual indicate the following operations.

Automatic:

The OSSDs immediately switches to the ON state when the conditions for doing so-such as the door closed-are met.

Manual:

Even if the conditions for switching the OSSDs to the ON state are met, the OSSDs maintain the OFF state (interlock state).

<Terminating the interlock state>

To set the OSSDs to the ON state and to start the machine, close the door to which the GS (Non-contact) has been installed and perform the reset operation after the preparations for starting the machine are complete. This sets the OSSDs to the ON state and terminates the interlock state.

Interlock function settings

Use the wiring to configure the settings. The wiring method varies depending on whether the "4-4 EDM Function" (page 6) is used.

Interlock function	EDM function	Reset/EDM input	Interlock/EDM function selection input
Automatic	Do not use	0 V	0 V
Automatic	Use	Connected to 24 V via a relay NC contact	Open
Manual	Do not use	Connected to 24 V via an NO reset switch	Connected to 24 V
Manual	Use	Connected to 24 V via an NO reset switch and a relay NC contact	Connected to 24 V

DANGER

- Be sure to absolutely confirm that there is nobody in the hazardous zone before the interlock condition is terminated (i.e. the machine system restarts) by the interlock reset mechanism.
- Install the switch, etc. for releasing the interlock state in a position where it is possible to check the entirety of the hazardous zone and where the switch, etc. cannot be operated from within the hazardous zone.
- When the interlock function is set to Automatic, it is necessary to ensure the safety of the entire control system in order to prevent unexpected starts from occurring.
- Exercise caution to prevent the reset/EDM input from forming a short circuit with other inputs or outputs.

4-4 EDM Function Advanced function type

The GS (Non-contact) can monitor the state of external devices, such as a safety relay or contactors that are connected to the OSSDs, in order to detect the failure of the external device. This monitoring function is called the EDM function.

EDM function settings

Use the wiring to configure the settings. The wiring varies depending on whether the interlock function is used. For details, see "4-3 Interlock Function" (page 6).

4-5 AUX Output

This is an informational output used to check the operating status of the GS (Non-contact).

DANGER The AUX outputs cannot be used as the safety outputs to a safety-related control system.

4-6 Coding Level

The GS (Non-contact) has two coding levels.

Coding level: Low (multi operation)	Any actuator is detected when it enters the range of the operating distance from the sensor. (Initial setting)
Coding level: High (unique operation)	Only the specific actuator that the sensor has been taught to detect is detected when it enters the range of the operating distance from the sensor. The sensor does not respond if an actuator other than the actuator that it has been taught to detect is within the range of the operating distance.

Chapter 5 Specifications

5-1 Model Number Description

Main unit

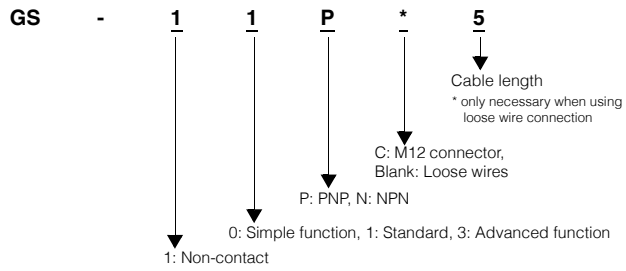

Cable

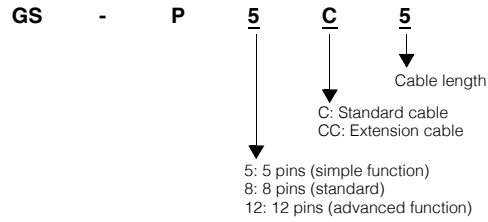

5-2 Specifications

Specifications

Model	GS-10PC	GS-11P5	GS-11N5	GS-11P10	GS-11N10	GS-11PC	GS-13P5	GS-13PC	
Type	Simple function type		Standard type				Advanced function type		
Output type	PNP	PNP	NPN	PNP	NPN	PNP	PNP	PNP	
Operating distance	Front	Sao (OFF → ON)		10 mm					
	Front	Sar (ON → OFF)		18 mm					
Side	Side	Sao (OFF → ON)		6 mm					
	Side	Sar (ON → OFF)		14 mm					
Response time (ms) ¹	Detection	Detect → Not detect		20 ms + 2 ms × (number of cascaded unit - 1)					
		Not detect → Detect		30 ms + 25 ms × (number of cascaded unit - 1)					
Door operation	Acceptable operation frequency	3 Hz							
	Standard	-	Max. 30 units						
Cascading	Using Y-shaped connector	-	-				Max. 4 units ²	-	
	Output	Transistor outputs × 2							
Control output (OSSD output)	Max. load current	PNP: Max. 150 mA, NPN: Max. 100 mA							
	Residual voltage (during ON)	Max 2.5 V (with a cable length of 5 m)							
	OFF state voltage	Max 2.0 V (with a cable length of 5 m)							
	Leakage current	Max. 500 μA							
	Max. capacitive load	2.2 μF							
	Load wiring resistance	Max. 2.5 Ω							
AUX (Non-safety-related output)	Output	Transistor output							
	Number of output	1							
	Max. load current	50 mA							
	Residual voltage (during ON)	Max 2.5 V (with a cable length of 5 m)							
External input (Short-circuit current)	Safety input	-	Approx. 1.5 mA × 2						
	Reset/EDM input	-	-				Approx. 5.0 mA × 1		
Power supply	Power voltage	24 V DC ±20 % (Ripple P-P 10 % or less, Class2)							
	Power consumption	0.8 W							
Protection circuit		Reverse current protection, short-circuit protection and surge protection for each output							
Environmental resistance	Enclosure rating	IP65/67(IEC60529), IP69K(ISO20653) (TUV SUD certified) Enclosure Type 3/4X/12/13 (NEMA250)							
	Operating ambient temperature	-20°C to +55°C (No freezing)							
	Storage temperature	-25°C to +70°C (No freezing) ³							
	Operating relative humidity	5% to 95%RH							
	Storage relative humidity	5% to 95%RH							
	Vibration resistance	10 to 55 Hz, Double amplitude 3.0 mm, 5 minutes in each of the X, Y, and Z directions (IEC 60947-5-3)							
Shock resistance	30 G in X, Y, Z directions 6 times each axis (IEC 60947-5-3)								
Material	Sensor main unit	Case	Zinc die cast (Nickel chrome plating), PBT, PAR						
	Cable	PVC							
	Actuator	Case	SUS430, SUS304, PBT						
Weight	Approx. 80 g		Approx. 270 g		Approx. 480 g		Approx. 80 g	Approx. 280 g	Approx. 80 g

¹ Risk time according to IEC60947-5-3 is 150 ms + 2 ms × (number of cascaded units - 1).

² When AUX outputs of each unit are not used, it is possible to cascade up to 10 units.

³ When stored for a long period of time, please store it at temperature of 55°C or lower.

Safety-related parameters

Mission time	20 years
Hardware fault tolerance	1
Type of element	B
Performance level	e
Category	4
SIL	3

PFH (IEC 61508)

Interlocking function	4.78×10 ⁻¹⁰
-----------------------	------------------------

Chapter 6 Appendix

6-1 Indicator Descriptions

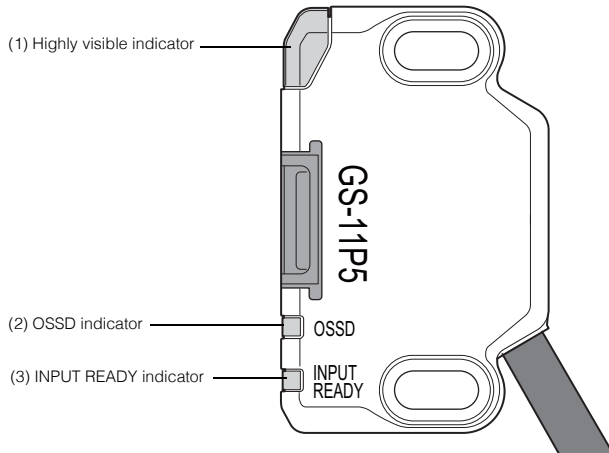

(1) Highly visible indicator

Light color	Status	Details	OSSD status	Actuator detection status
Green	ON	During normal operation.	ON	Detected
Orange	Blinking (fast)	During operation with the "High" coding level, an actuator different from the one that was taught was detected.	OFF	Incorrect actuator detected
		Error during coding level switching		Uncertain
Red	Blinking	Switching coding level or teaching for an actuator	OFF	Uncertain
	ON	Door, etc. is open.	OFF	Not detected
Red	Blinking	Error state. The GS (Non-contact) has detected an error.	OFF	Uncertain
OFF	—	Power OFF.	OFF	Uncertain

(2) OSSD indicator

Light color	Status	Details	OSSD status	Actuator detection status
Green	ON	The OSSD is ON.	ON	Detected
	Blinking	The OSSD is ON but the state is unstable such as the door starting to open.	ON	Detected
Red	ON	The OSSD is OFF.	OFF	Uncertain

(3) INPUT READY indicator

Light color	Status	Details	OSSD status	Actuator detection status
Yellow	ON	Interlock release wait state (waiting for reset input).	OFF	Detected
	Blinking	Safety inputs are OFF.	OFF	Uncertain
OFF	—	Other state.	Uncertain	Uncertain

6-2 Dimensions

Direct mounting

Sensor main unit

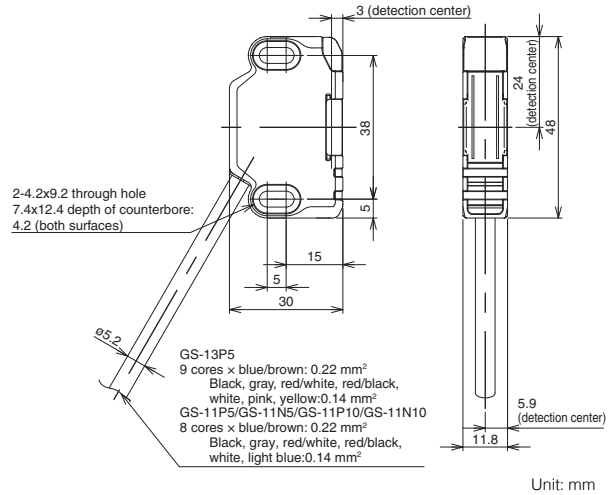

Actuator

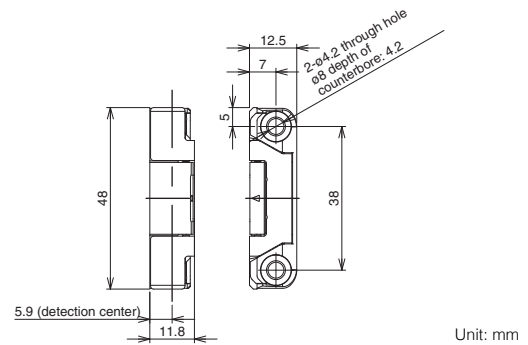

6-3 Troubleshooting

If the operation of the GS (Non-contact) is abnormal, identify the cause of the error and carry out the countermeasures according to the following tables.

■ [A] The OSSD does not turn ON (or turns OFF unexpectedly).

Possible cause	Confirmation method	Countermeasure
The GS (Non-contact) is in the error state.	The highly visible indicator is blinking in red.	Identify the cause of the error and implement countermeasures according to "Display details when an error occurs."
The actuator is not detected correctly.	The highly visible indicator is ON in red.	Bring the actuator within the detection range.
The actuator is broken.		Replace the actuator.
During operation with the "High" encoding level, an actuator different from the one that was taught was detected.	The highly visible indicator is blinking in orange.	Use the actuator that was taught to the unit.
Safety input is not ON.	The INPUT READY indicator is blinking in yellow.	Turn ON the safety input.
The unit is in the interlock reset ready state.	The INPUT READY indicator is ON in yellow.	Release the interlock state by turning the RESET/EDM input ON.
The sensor and actuator are at a greater distance than the specified operating distance Sao (OFF → ON).	-	Check the installation.
The unit is affected by the surrounding metal.	-	Check the installation.
The unit is affected by interference from other sensors.	-	Check the installation.

■ [B] The OSSD does not turn OFF (or turns ON unexpectedly).

Possible cause	Confirmation method	Countermeasure
The sensor and actuator are at a shorter distance than the specified operating distance Sar (ON→OFF).	-	Check the installation.
The unit is affected by the surrounding metal.	-	Check the installation.
The unit is affected by interference from other sensors.	-	Check the installation.
The cascade connection wiring is incorrect.	The INPUT READY indicator is off.	Check the safety input wiring.

■ [C] The OSSD sometimes turns ON and OFF.

Possible cause	Confirmation method	Countermeasure
The sensor is subject to noise.	-	Check the noise environment around the wiring.
The unit is affected by the surrounding metal.	-	Check the installation.
The unit is affected by interference from other sensors.	-	Check the installation.
The sensor and actuator are at a distance between the specified operating distance Sao (OFF→ON) and Sar (ON→OFF).	-	Check the installation.

■ [D] The connected device repeatedly turns the OSSD ON/OFF at high speed (chattering).

Possible cause	Confirmation method	Countermeasure
The OSSDs turn OFF periodically by the self-diagnosis function, but the connected device may be recognizing this short OFF signal.	-	Select a device that does not detect the OSSD's periodic OFF signal for the connected device.

■ [E] No indicators light.

Possible cause	Confirmation method	Countermeasure
The power is off or the power supply voltage is insufficient.	Power supply voltage or power supply wiring	Ensure that the power supply voltage is within the range in the specifications. Wire the power supply correctly.
An extension cable or other such connector cable is not connected correctly.	Connection status of connector cables	If necessary, connect the parts again.

6-4 Inspection and Maintenance

Inspect the safety function of the GS (Non-contact) on the basis of the results of a risk assessment of the target machine. It is strongly recommended that, at minimum, the following items and periods be met.

	<ul style="list-style-type: none"> • To prevent danger due to the machine starting, thoroughly ensure that no one is present in the hazardous zone during inspection. • If some error is found on the GS (Non-contact) as a result of the inspection, do not operate the machine.
---	---

• Initial inspection

Items

- The sensor and actuator are installed on the basis of the installation conditions, installation methods, and wiring specifications specified in this manual.
- The safety functions being used ("4-1 OSSD" (page 5), "4-2 Safety Input" (page 6), "4-3 Interlock Function" (page 6), or "4-4 EDM Function" (page 6)) operate as intended.

• Periodic inspection

Periods

SIL3/PLe: Once/month or more, SIL2/PLd: Once/year or more (ISO 14119)

Items

- If an emergency stop switch is connected to the safety input, the safety function acts correctly when the emergency stop switch is pressed.
- There are no changes in the mounting conditions of the sensor and actuator or in the doors, etc. to which these devices are installed.
- The door, etc. is not deformed.
- There are no changes to the installation status that will affect the results of the risk assessment carried out at the start of the installation.
- The mounting screws and seals (in the case that seals have been applied to the manual release) have been applied correctly.
- No excessive damage or dirt is present.

Especially in the following cases, check the same details as the initial inspection.

- When a change is made to the installation, wiring, or functions
- When the sensor or actuator is replaced
- When the equipment is not used for a long period of time
- When a defect occurs

Store the inspection results together with the machine's records.

Errors found on the sensor or actuator cannot be repaired by the customer. Replace the product with a new one or contact the nearest KEYENCE office.

WARRANTIES AND DISCLAIMERS

- (1) KEYENCE warrants the Products to be free of defects in materials and workmanship for a period of one (1) year from the date of shipment. If any models or samples were shown to Buyer, such models or samples were used merely to illustrate the general type and quality of the Products and not to represent that the Products would necessarily conform to said models or samples. Any Products found to be defective must be shipped to KEYENCE with all shipping costs paid by Buyer or offered to KEYENCE for inspection and examination. Upon examination by KEYENCE, KEYENCE, at its sole option, will refund the purchase price of, or repair or replace at no charge any Products found to be defective. This warranty does not apply to any defects resulting from any action of Buyer, including but not limited to improper installation, improper interfacing, improper repair, unauthorized modification, misapplication and mishandling, such as exposure to excessive current, heat, coldness, moisture, vibration or outdoors air. Components which wear are not warranted.
- (2) KEYENCE is pleased to offer suggestions on the use of its various Products. They are only suggestions, and it is Buyer's responsibility to ascertain the fitness of the Products for Buyer's intended use. KEYENCE will not be responsible for any damages that may result from the use of the Products.
- (3) The Products and any samples ("Products/Samples") supplied to Buyer are not to be used internally in humans, for human transportation, as safety devices or fail-safe systems, unless their written specifications state otherwise. Should any Products/Samples be used in such a manner or misused in any way, KEYENCE assumes no responsibility, and additionally Buyer will indemnify KEYENCE and hold KEYENCE harmless from any liability or damage whatsoever arising out of any misuse of the Products/Samples.
- (4) **OTHER THAN AS STATED HEREIN, THE PRODUCTS/SAMPLES ARE PROVIDED WITH NO OTHER WARRANTIES WHATSOEVER. ALL EXPRESS, IMPLIED, AND STATUTORY WARRANTIES, INCLUDING, WITHOUT LIMITATION, THE WARRANTIES OF MERCHANTABILITY, FITNESS FOR A PARTICULAR PURPOSE, AND NON-INFRINGEMENT OF PROPRIETARY RIGHTS, ARE EXPRESSLY DISCLAIMED. IN NO EVENT SHALL KEYENCE AND ITS AFFILIATED ENTITIES BE LIABLE TO ANY PERSON OR ENTITY FOR ANY DIRECT, INDIRECT, INCIDENTAL, PUNITIVE, SPECIAL OR CONSEQUENTIAL DAMAGES (INCLUDING, WITHOUT LIMITATION, ANY DAMAGES RESULTING FROM LOSS OF USE, BUSINESS INTERRUPTION, LOSS OF INFORMATION, LOSS OR INACCURACY OF DATA, LOSS OF PROFITS, LOSS OF SAVINGS, THE COST OF PROCUREMENT OF SUBSTITUTED GOODS, SERVICES OR TECHNOLOGIES, OR FOR ANY MATTER ARISING OUT OF OR IN CONNECTION WITH THE USE OR INABILITY TO USE THE PRODUCTS, EVEN IF KEYENCE OR ONE OF ITS AFFILIATED ENTITIES WAS ADVISED OF A POSSIBLE THIRD PARTY'S CLAIM FOR DAMAGES OR ANY OTHER CLAIM AGAINST BUYER.** In some jurisdictions, some of the foregoing warranty disclaimers or damage limitations may not apply.

BUYER'S TRANSFER OBLIGATIONS:

If the Products/Samples purchased by Buyer are to be resold or delivered to a third party, Buyer must provide such third party with a copy of this document, all specifications, manuals, catalogs, leaflets and written information provided to Buyer pertaining to the Products/Samples.

E 1101-3

Document Control No. 1477BAE201

KEYENCE CORPORATION

1-3-14, Higashi-Nakajima, Higashi-Yodogawa-ku,
Osaka, 533-8555, Japan
PHONE: +81-6-6379-2211

www.keyence.com

AUSTRIA Ph: +43-2236-378266-0	HONG KONG Ph: +852-3104-1010	NETHERLANDS Ph: +31-40-20-66-100	TAIWAN Ph: +886-2-2721-8080
BELGIUM Ph: +32-15-281-222	HUNGARY Ph: +36-1-802-73-60	PHILIPPINES Ph: +63-2-981-5000	THAILAND Ph: +66-2-369-2777
BRAZIL Ph: +55-11-3045-4011	INDIA Ph: +91-44-4963-0900	POLAND Ph: +48-71-36861-60	UK & IRELAND Ph: +44 1908-696-900
CANADA Ph: +1-905-366-7655	INDONESIA Ph: +62-21-2966-0120	ROMANIA Ph: +40-269-232-808	USA Ph: +1-201-930-0100
CHINA Ph: +86-21-3357-1001	ITALY Ph: +39-02-6688220	SINGAPORE Ph: +65-6392-1011	VIETNAM Ph: +84-24-3772-5555
CZECH REPUBLIC Ph: +420-220-1847-00	KOREA Ph: +82-31-789-4300	SLOVAKIA Ph: +421-25939-6461	
FRANCE Ph: +33-1-56-37-78-00	MALAYSIA Ph: +60-3-7883-2211	SLOVENIA Ph: +386-1-4701-666	
GERMANY Ph: +49-6102-3689-0	MEXICO Ph: +52-55-8850-0100	SWITZERLAND Ph: +41-43-455-77-30	

Specifications are subject to change without notice.

A6WW1-MAN-1058

Copyright (c) 2018 KEYENCE CORPORATION. All rights reserved.
15311E 1098-1 [96M15311] Printed in Japan

