

# HORIZONTAL ROTOR

## MODEL **KR-600 RC**

### **INSTRUCTION MANUAL**

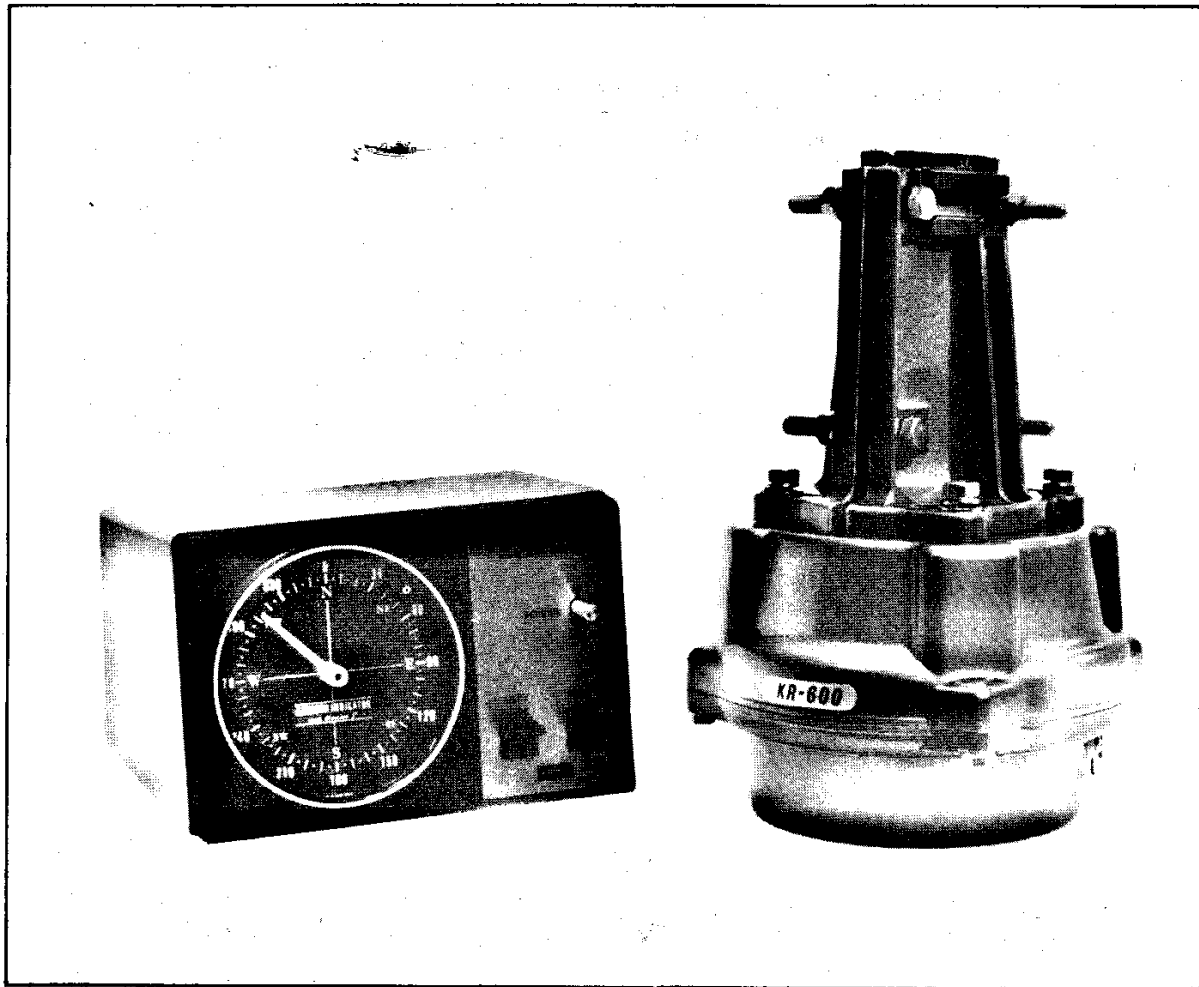

INSTRUCTION MANUAL FOR  
KR-600RC ROTOR

The KENROTOR KR-600RC is designed to support and rotate medium-sized short wave amateur antenna or heavy TV antenna arrays.

When installing your antenna, follow the instructions given carefully for highly dependable long-life performance.

Careless or erroneous installation might result in poor durability.

**SPECIFICATIONS:**

Input Voltage	117/230VAC, 50/60Hz
Power Consumption	40VA
Motor	24V Split Phase
Rotation Time	Approx. 53 sec/60Hz 63 sec/50Hz
End-of-Rotation Stopper	Electrical and Mechanical
Rotation Torque	600 kg-cm(520 Lbs-in)
Stationary Brake Torque	4000kg-cm(3,470Lbs-in)
Vertical Load	200 kg (440 Lbs.)
Permissible Mast Size	38~63 $\phi$ (1 $\frac{1}{2}$ ~2 $\frac{1}{2}$ in)
Cable	6 conductor cable #22 or larger
Weight	
Rotor	4.5kg (9.9 Lbs)
Controller	3.2kg (1.5 Lbs)

KENROTOR KR-600RC features:

**DEPENDABILITY:** Rotor unit is housed in a weather-sealed and factory-lubricated die-cast aluminum housing with melamine-resin coating.

**QUIET OPERATION:** Reduction gear train with moulded plastic pinions and die-cast spurs assures smooth and practically silent operation  
Gears in lower revolution part are surfacehardened throughout for dependable long-life operation.

**NEWLY DESIGNED CONTROLLER:** Large round type meter for direct-point direction indication.  
Solid state stabilized power supply in the meter circuit provides precisely resettable direction, independent of line voltage fluctuation.  
Once set, no recheck of calibration is necessary.

**MECHANICAL END-OF-ROTATION STOPS:** Rotation stops automatically at the end of each 360° rotation.

**EASY-ALIGNING MAST CLAMPS:** Our new mast gauge (pat. pending) eliminates any aligning problem.  
An antenna mast of 38~6sø (1½~2½ in) in diameter can be accomodate.

**SIMPLE AND EASY WIRING:** Only a screw-driver is all that is required. No other tool is necessary.  
Drip-proof plastic cover protects terminal on the rotor unit.

**EASY SETTING START POSITION OF THE NEEDLE:** The KR-600RC can be used in any conditions of location as starting position of indicator needle can be freely changable as you like.

Fig. 1.

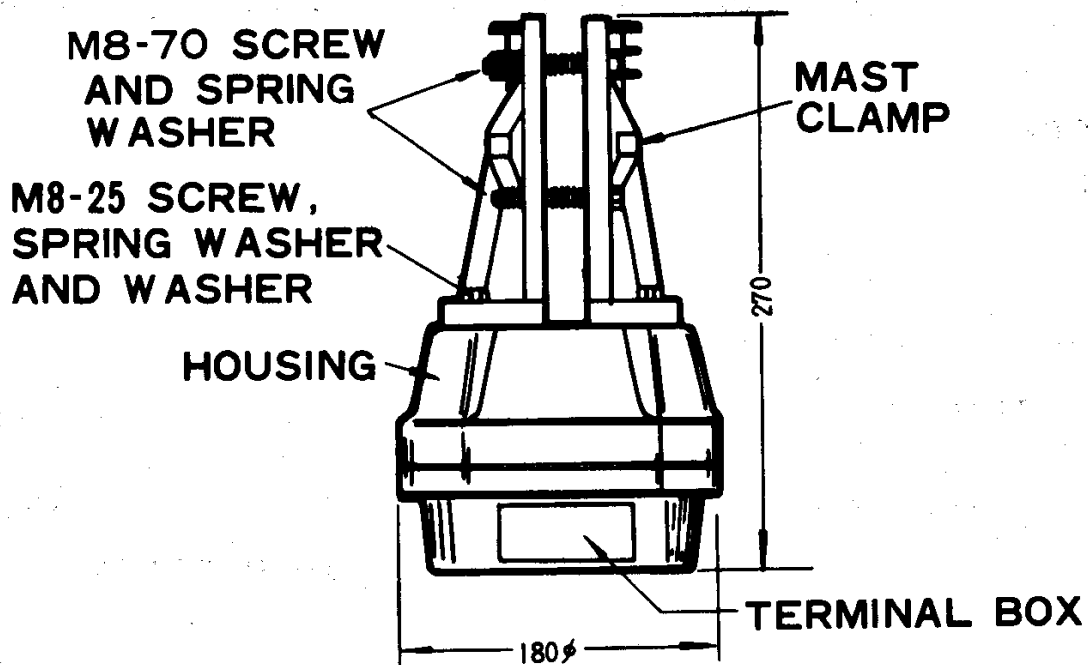

MUST BE USE M8-16 SCREW  
IN CASE OF MOUNTING  
ON A TOWER

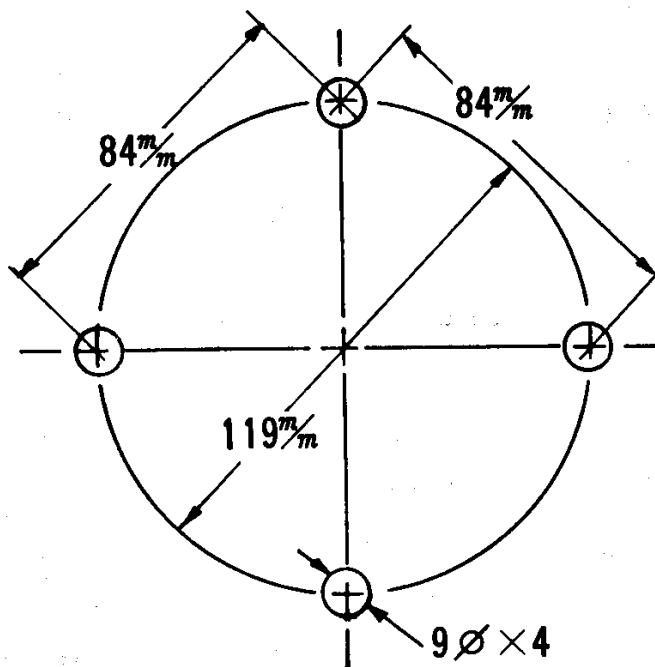
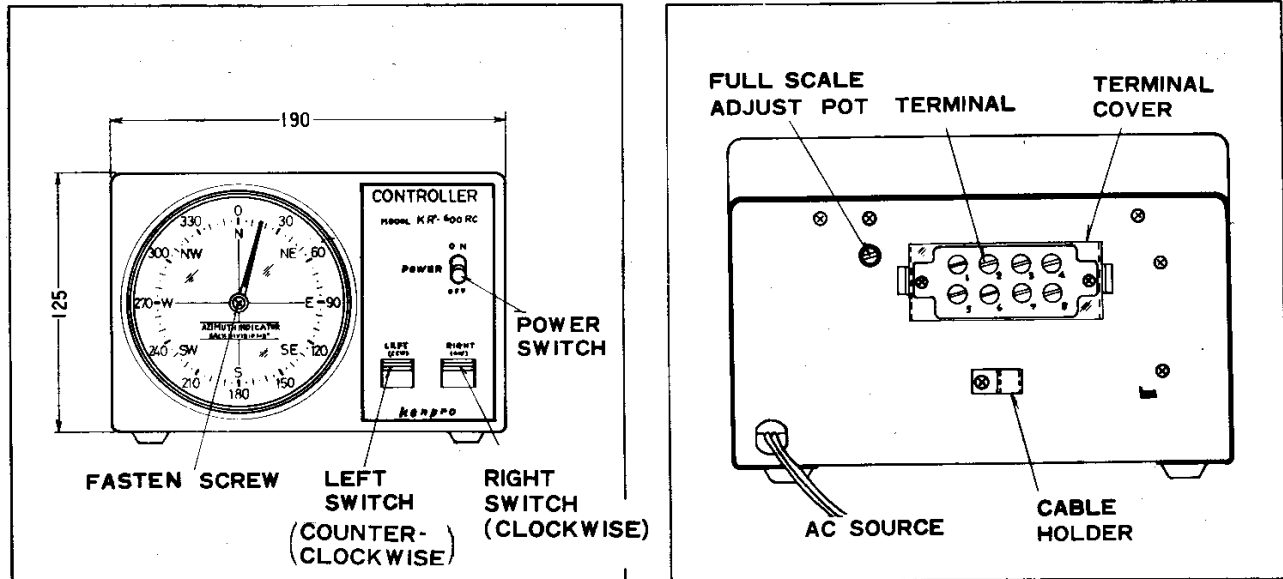

Fig.2



**UNPACKING**

Remove your KENROTOR KR-600 from its packing carton and check each item.

Rotator Unit	1
Controller Unit	1
Mast Clamp	1
Hex. Hd. Bolt	
M8-16	4
M8-25	4
M8-70	4
Hex. Nut M8	4
Spring Washer	12
Washer	4
Instruction Manual	1

Examine if the equipment has been damaged in shipment,  
 save the carton and packing material and notify the transportation company immediately.

## ELECTRICAL INTER CONNECTION

IT IS RECOMMENDED THAT AN ON-THE-GROUND CHECK BE MADE PRIOR TO ACTUAL INSTALLATION TO DISCOVER ANY POSSIBLE WIRING ERRORS

Referring to Fig.3, slide the terminal cover to the rotator unit over the 6 conductor cable.

Strip, twist the standards of each conductor and tin them lightly with solder.

Wire each conductor to each terminal.

The other end of the cable to be connected to the corresponding terminals of the control unit, as illustrated Fig.3.

Replace the terminal cover on the rotor unit.

Plug the line cord into an AC power outlet of the correct voltage depending on control box model.

The power switch ON and pilot lamp should light, and direction needle moves until position of rotor direction which is set up in advance and stops.

Press LEFT or LIGHT switch the needle turns to varantaly direction and rotor rotates to same direction.

WHEN PRESSING BOTH RIGHT AND LEFT SWITCHES  
SIMULTANEOUSELY, MOTOR RUNS TO COUNTER-CLOCKWISE.

Fig. 3

## INTERCONNECTION

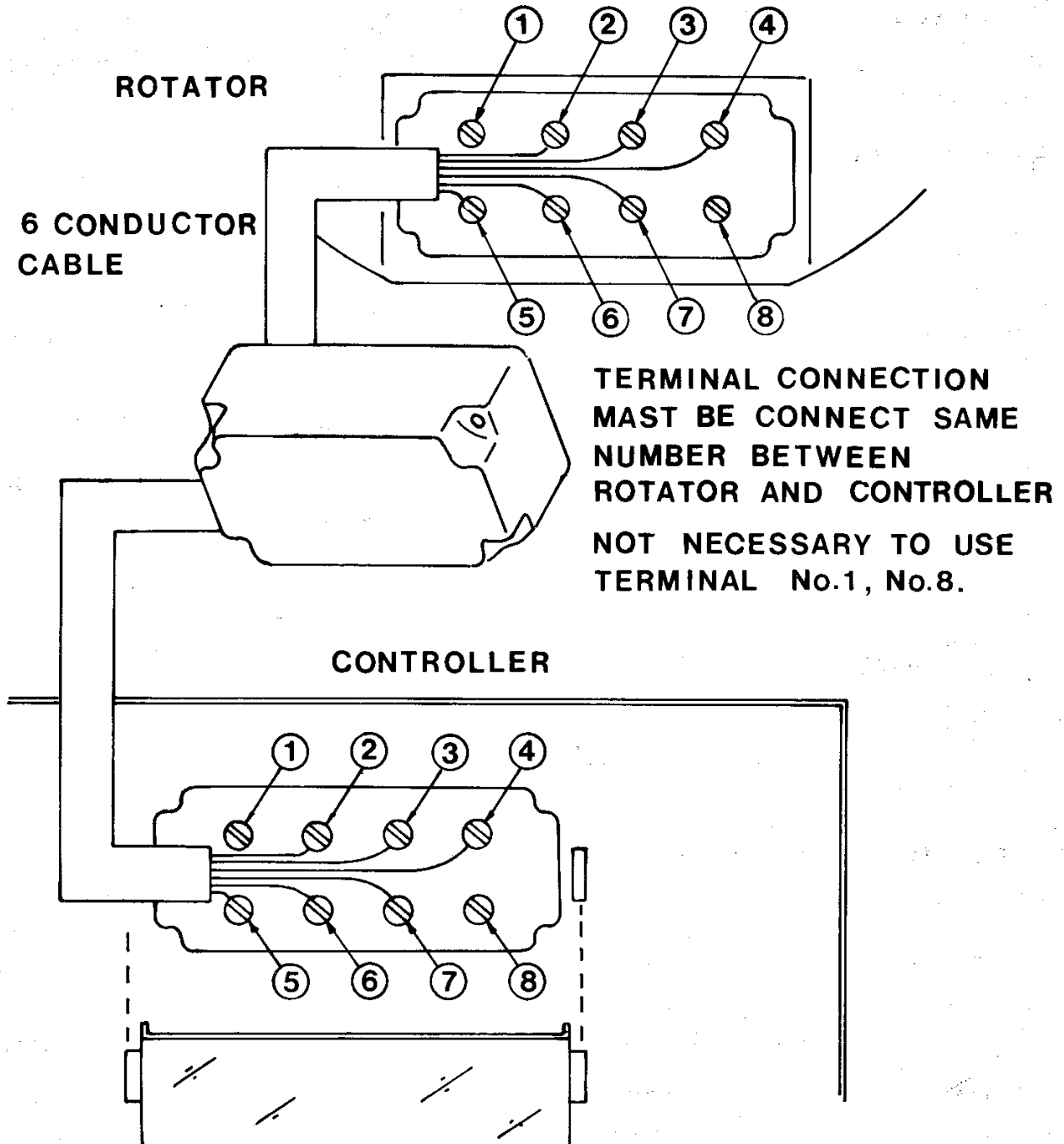

## CALIBRATION

Press LEFT switch and rotates to full counter-clockwise the indicator needle will indicate N(0°).

If not, unfasten the screw and remove indicator needle, then set up to the N(0°) position.

Fig. 4

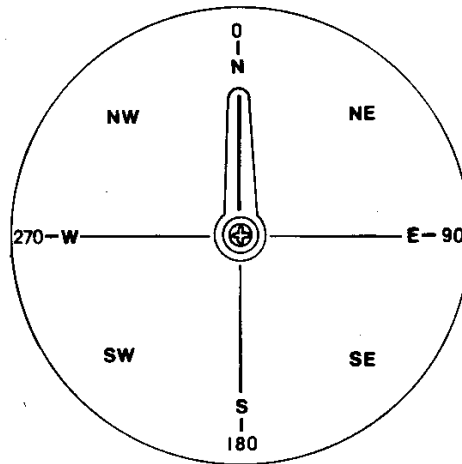

Press RIGHT switch and rotates to full clockwise, the needle will indicate 360°.

If not, adjust to 360° by potentiometer on the rear panel.

Fig. 5

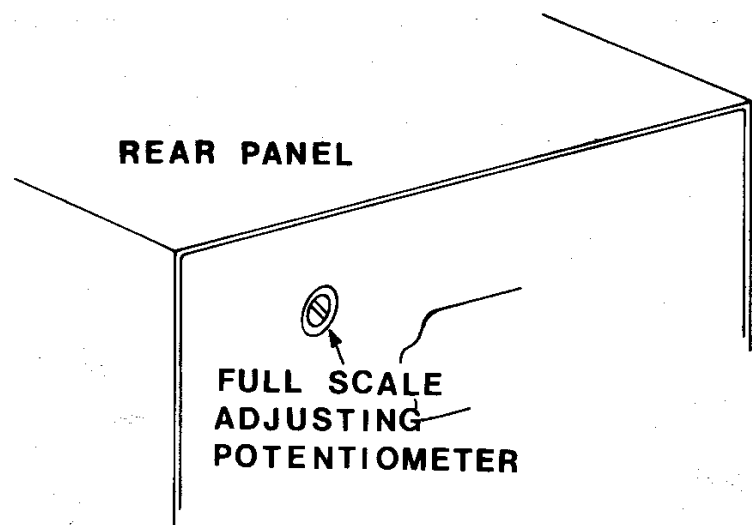
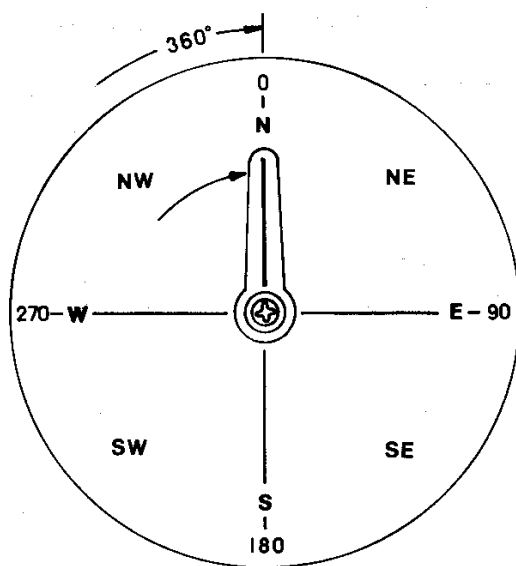



## INSTALLATION:

The KENROTOR KR-600RC can be mounted on a mast top of a tower or inside tower.

It is designed for use with medium-sized antennas. The maximum load capability of a rotator is quite dependent on the physical size of antenna, mechanical installation, location of your shack and wind velocity.

Illustrated in Fig. 6 and 7 are the result of our long field experience and accumulation of know-how.

An Antenna should be mounted as close to the rotor as possible. Wind pressure against the antenna produces a bending force on the mast which is proportional to the length of the mast used. we suggest three feet of antenna support pipe as the practical limit.

Weight of the antenna should be balanced on either side of the boom at the mast-to-boom clamp.

Balanced weight produces only axial down thrust on the rotor and our KR-600RC has the axial load rating of as high as 440 Lbs.

Unbalanced installation results in some leverage force which strains the mast at the clamping point on the rotor. Great care to be given especially in high wind areas.

When installing a bigger-than-medium-sized antenna, inside tower mounts with our KS-065 BEARING located at the top of the tower is recommended.

Extreme care must be taken to get the TOP BEARING ALIGNED exactly to the center of rotor.

Size of 6 conductor cable is important. #22 cable is good to about 100 feet, beyond that #20 cable

or larger should be used

When running co-axial cable be sure to leave enough slack to allow the antenna to rotate a full 360°.

Fig.6

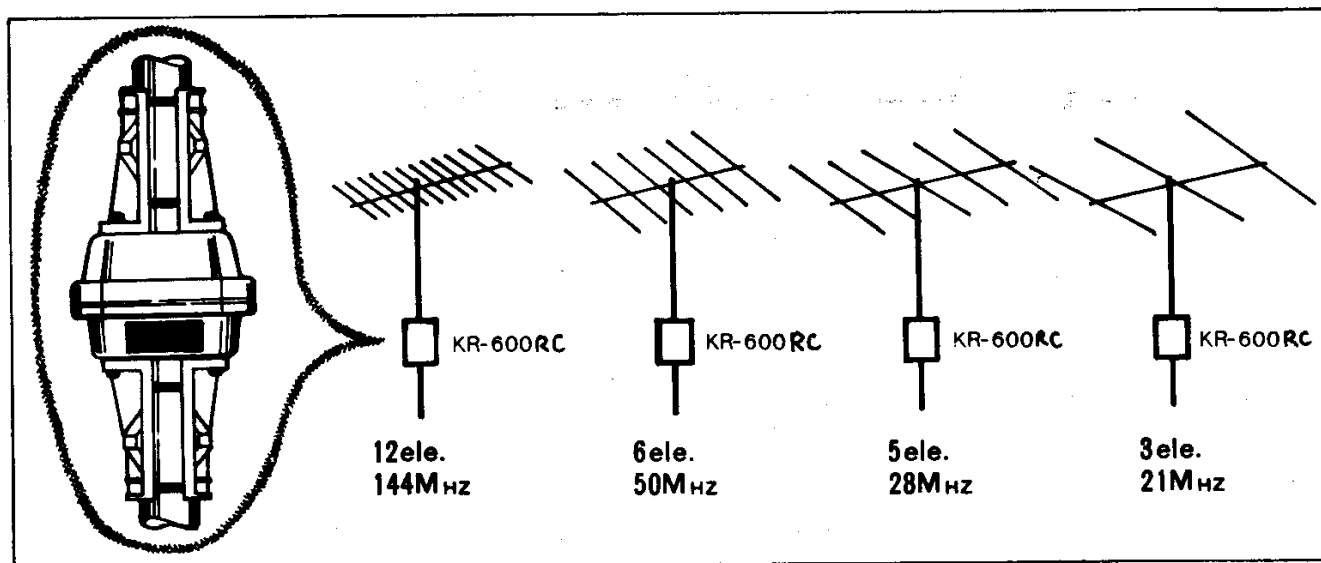
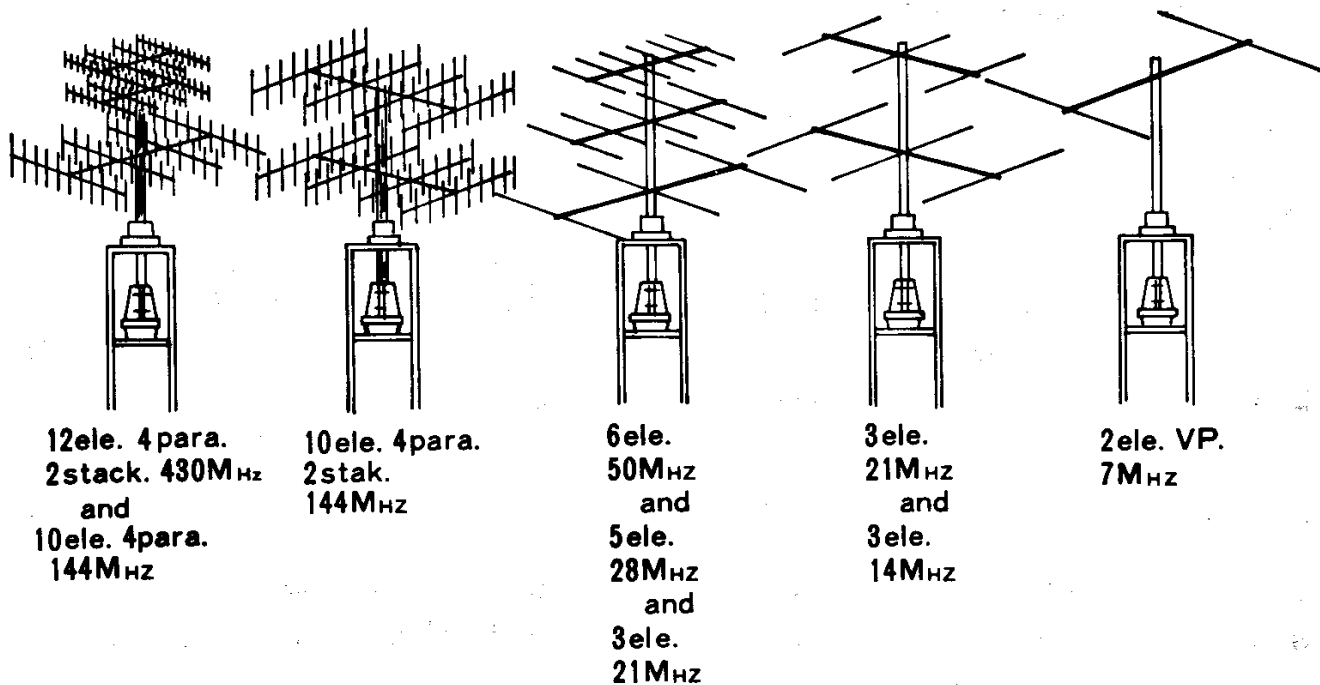

Fig.4 Inside Tower Installation



**CAUTION:**

When not in use, turn the power switch to OFF.

Rotor gear train is braked mechanically, when the indicator reads STOP at each end.

Release the switch immediately.

If keep pressing switch, damage on the motor or gear train might occur.

The motor used is of a five minutes intermittent rating. However it can continuously run for as long as ten minutes, provided the motor be brought to rest for no less than ten minutes afterwards.

# MODEL KR-600RC ROTOR

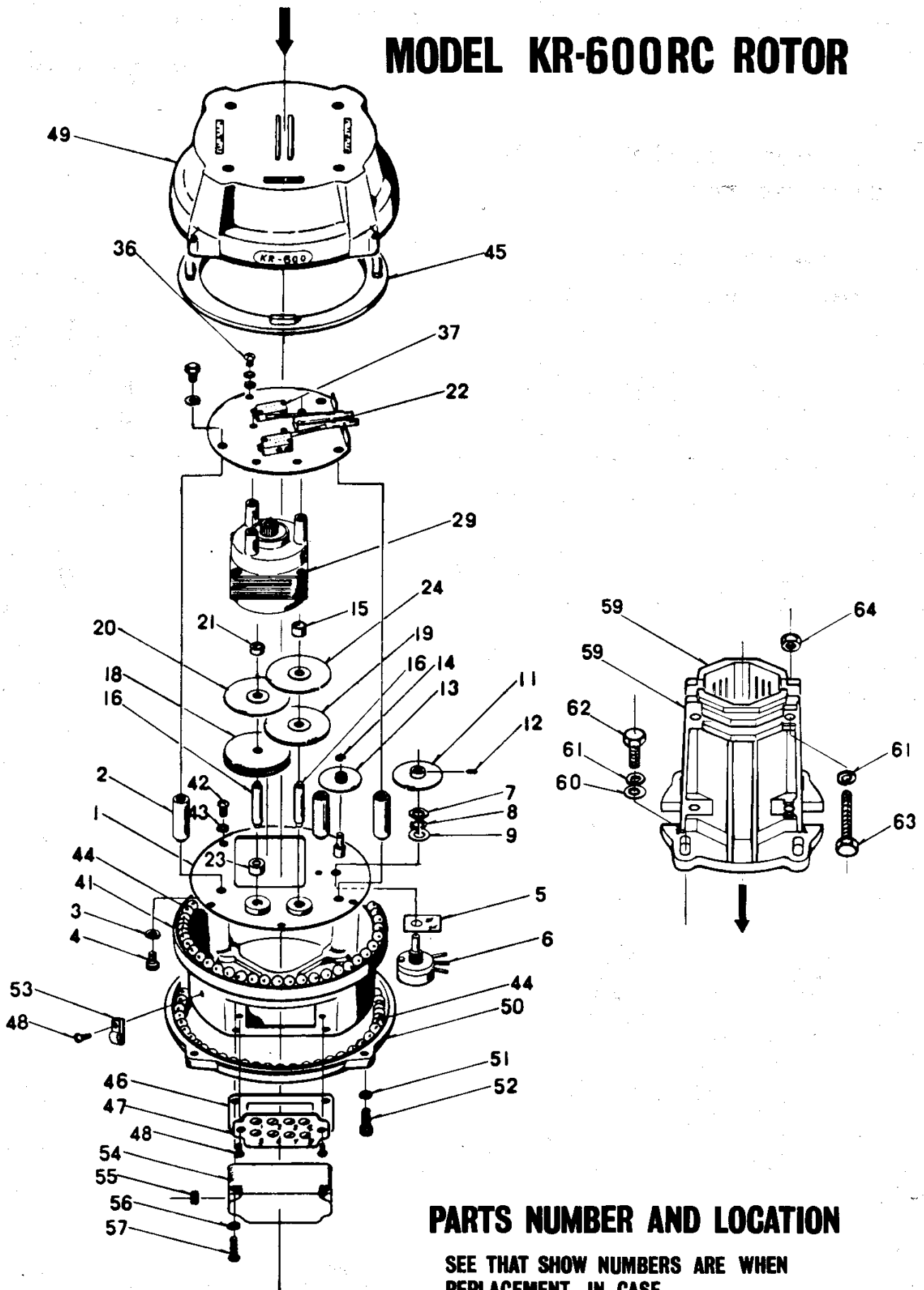

## PARTS NUMBER AND LOCATION

SEE THAT SHOW NUMBERS ARE WHEN REPLACEMENT IN CASE

PARTS LIST (ROTOR)

- |  |                                      |
|--|--------------------------------------|
| 1. Gear Mount Plate Ass'y                    |                                      |
| 2. Gear Mount Support                        |                                      |
| 3. Washer (6 $\phi$ )                        |                                      |
| 4. Gear Mount Screw                          |                                      |
| 5. Insulation Sheet                          |                                      |
| 6. Potentiometer                             |                                      |
| 7. Nut (9 $\phi$ )                           |                                      |
| 8. Spring Washer (9 $\phi$ )                 |                                      |
| 9. Washer (9 $\phi$ )                        |                                      |
| 11. Pot Divider Gear                         |                                      |
| 12. Gear Stopper Screw                       |                                      |
| 13. Plastic Pot Gear                         |                                      |
| 14. E Ring (2.5 $\phi$ )                     |                                      |
| 15, 21. Stud Support Sleeve                  |                                      |
| 16, 17. Gear Shaft                           |                                      |
| 18. Gear                                     |                                      |
| 19, 20. Pinion/Gear Ass'y                    |                                      |
| 22. Gear/Motor Mount Ass'y                   |                                      |
| 29. Motor Ass'y                              |                                      |
| 34, 35, 56. Washer (4 $\phi$ )               |                                      |
| 36. Screw for Motor Holder (4 $\phi$ )       |                                      |
| 37. Limit Switch                             |                                      |
| 41. Case                                     |                                      |
| 42. Screw for Mount Plate Holder (5 $\phi$ ) |                                      |
| 43. Washer (5 $\phi$ )                       |                                      |
| 44. Ball Bearing                             |                                      |
|  | 45. Internal Gear                    |
|  | 46. Rubber Sheet                     |
|  | 47. Terminal                         |
|  | 48. Terminal/Cable Holder Screw      |
|  | 49. Rotor Housing                    |
|  | 50. Housing                          |
|  | 51. Washer (6 $\phi$ )               |
|  | 52. Housing Screw                    |
|  | 53. Cable Holder                     |
|  | 54. Terminal Cover                   |
|  | 55. Rubber Grommet                   |
|  | 57. Terminal Cover Screw (4 $\phi$ ) |
|  | 58, 59 Mast Clamp                    |
|  | 60. Washer (8 $\phi$ )               |
|  | 61. Spring Washer (8 $\phi$ )        |
|  | 62, 63. Screw (8 $\phi$ )            |
|  | 64. Hex. Nut M8                      |

KR-600RC SCHEMATIC DIAGRAM

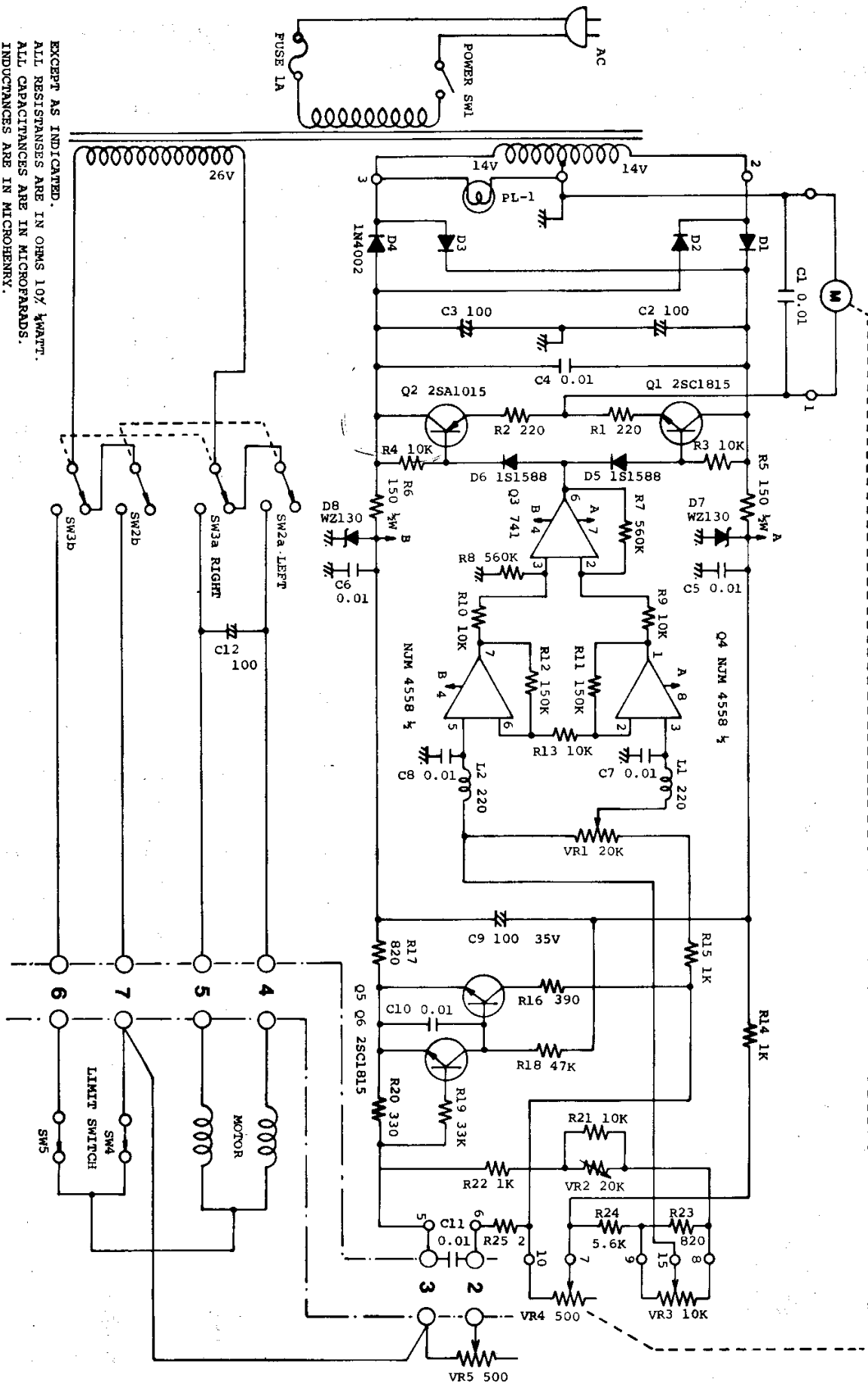

EXCEPT AS INDICATED,  
ALL RESISTANCES ARE IN OHMS 10% WATT.  
ALL CAPACITANCES ARE IN MICROFARADS.  
INDUCTANCES ARE IN MICROHENRY.

## WARRANTY

TOYOMURA ELECTRONICS CO., LTD. warrants the KR-600RC ANTENNA ROTOR to be free from defect in material arising from normal usage. Its obligation under this warranty is limited to replacing, or at its option repairing the rotor which, after regular installation and under normal usage and the validity of this warranty is for ONE YEAR from date of original consumer purchase.

The obligation of TOYOMURA ELECTRONICS CO., LTD. does not include either the making or the furnishing of any labour in connection with the installation of such repaired responsibility for any transportation expense.

This warranty does not extend if model KR-600RC antenna rotor has been subjected to misuse neglect accident, interconnect wiring, improper installation or to use in violation of the instructions furnished by us, nor does it extend to units which have been repaired or altered outside our service department, nor in cases where the serial number has been removed, defaced, or changed nor to units used with accessories not manufactured or recommended by us.

**KENPRO INDUSTRIAL CO.,LTD**

SUGAWARA BLDG

NO.1-26-6, KITAOTSUKA, TOSHIMA-KU

TOKYO, JAPAN

TEL:03(576)8743 FAX:03(576)8745

---