

**GENERAL  
INSTALLATION  
& OPERATION  
INSTRUCTIONS**



**JETMASTER (VIC) PTY LTD**

ACN 005 872 159 ABN13 659 821 337

444 Swan St. Richmond VIC 3121 PO Box 5051 Burnley 3121

Phone: (03) 9429 5573 Fax: (03) 9427 0031

Website: [www.jetmaster.com.au](http://www.jetmaster.com.au) Email: [info@jetmastervic.com.au](mailto:info@jetmastervic.com.au)

# CONTENTS

JETMASTER UNIVERSAL - General Installation Instructions ..... 1

Summary of Minimum Jetmaster Installation Specs..... 2 - 3

Jetmaster Installation into an Existing Fireplace..... 4

OPEN WOOD JETMASTER - Minimum Flue Height ..... 5

Construction Specifications - Jetmaster Traditional Victorian..... 6

Construction Specifications - Jetmaster Brick Veneer Installation ..... 7

Construction Specifications - Jetmaster Installation Using Hebel..... 8

Construction Specifications - Jetmaster Traditional Space Saver ..... 9

Construction Specifications - Jetmaster Traditional Edwardian On Stud Wall ..... 10

Construction Specifications - Jetmaster Free Standing Metal Casing "A" ..... 11

Construction Specifications - Jetmaster Free Standing Metal Casing "B" ..... 12

Construction Specifications - Jetmaster Double Sided "A" ..... 13

Open Gas Jetmaster..... 14 -15

OPEN GAS FIREPLACE - Minimum Flue Height..... 16

Open Gas Jetmaster..... 17 - 18

Operating and Maintenance Instructions - For wood burning Jetmaster ..... 19 - 20

How to Fit Fascias..... 21

## JETMASTER UNIVERSAL - General Installation Instructions

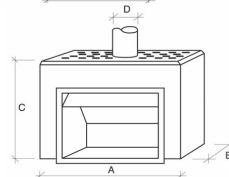
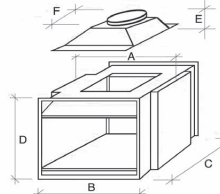
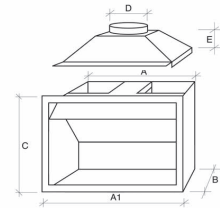

JETMASTER UNIVERSAL							
DIMENSIONS IN MILLIMETRES							Heating capacity Cu. Meters
MODEL	A	A1	B*	C	D	E	Wood
440	470	510	330	610	200	200	75
500	570	600	350	650	200	200	85
600	670	700	350	650	200	200	100
600 LOW	670	700	350	600	200	200	100
700 SH	770	800	350	650	200	200	130
700 SH LOW	770	800	350	600	200	200	130
700D	770	800	400	700	225	200	160*
850	920	950	450	750	250	220	180
850 LOW	920	950	450	700	250	220	180
1050	1120	1150	500	800	300	240	220
1200	1250	1300	605	1020	250**	400	300
1500	1550	1600	605	1020	300**	400	350

\*Tested to 15Kw at maximum burning.  
\*\* Requires 2 flue outlets (single flue option also available)

JETMASTER DOUBLE-SIDED							
DIMENSIONS IN MILLIMETRES							Heating capacity Cu. Meters
MODEL	A	B	C	D	E	F	Wood
700	800	800	610	700	220	345	200
1050	1205	1150	600	770	233	415	300

JETMASTER FREESTANDING					
DIMENSIONS IN MILLIMETRES					Heating capacity Cu. Meters
MODEL	A	B	C	D	Wood
600	1000	390	810	200	160
700 SH	1050	390	810	200	180
700D	1100	440	911	225	200
850	1200	490	983	250	240

### ASSEMBLY AND INSTRUCTION

- Position unit on finished hearth level - ensure air intake at base of unit is not obstructed;
- Bolt gather to unit;
- Insulate entire unit and gather where painted red;
- Bolt Lintel (optional) to unit - insulate between unit and Lintel;
- Rivet inner flue to collar of gather at three places;
- Rivet all further inner flues at three places;
- If using double skin flues space inner and outer flues using 3 x 25mm self tapping screws through outer casing at bottom, at each join and at top. Also ensure that flues are ventilated at top and bottom, and when using a cover cone drill a series of holes into the outer flue below the cover cone to ensure adequate ventilation;
- Fit cowl to flue or chimney breast.

### RECOMMENDATIONS

- Do not recess unit by more than 110mm
- Use a minimum of 3.6 metres lengths of flue

**1. HEARTH**

Must be constructed from a non combustible material such as concrete, brick, or autoclaved aerated lightweight concrete block.

- Models 400-700D must be minimum 26mm thick.
- Models 850 - 1500 must be minimum 100mm thick. This includes selected finish such as ceramic tiles, marble or granite.
- Must project forward of aperture by a minimum of 300mm.
- Must project either side of aperture by a minimum of 200mm.

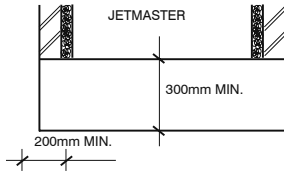
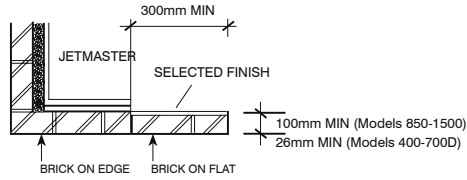

**2. FLUE**

- Single skin flue (stainless steel) must be enclosed with single skin brickwork, concrete, or autoclaved aerated concrete block.
- Twin skin flues (stainless steel inner, and galvanised outer) can either be left exposed or enclosed with stud walls and sheet plaster or timber. A minimum of 50mm clearance must be maintained between the outer flue and any combustibles. If using double skin flues space inner and outer flues using 3x25mm self tapping screws through outer casing at bottom, at each join and at top. Also ensure that flues are ventilated at top and bottom, and when using a cover cone drill a series of holes into the outer flue below the cover cone to ensure adequate ventilation.
- Fit cowl to flue or chimney breast.



**3. ENCLOSURE**

- A minimum of single skin brickwork, concrete, or autoclaved aerated concrete block must surround the firebox and gather at back, sides and front. A minimum of 25mm air gap filled with insulation material provided must be maintained.

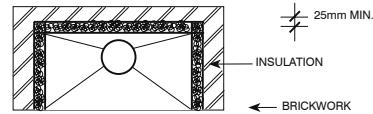

## Jetmaster Installation into an Existing Fireplace

- Step 1.** Measure the width, depth and height of your recess, too large or too small a recess presents no problem at all.
- Too Large** – The recess can be reduced by inserting bricks at the sides, and/or back, and, where necessary, between the top of the unit and the underside of the lintel.
  - Too Small** – The recess can be made deeper by removing the Rollback and Smokeshef. If the sides have to be removed this can be done, however, it is suggested that an experienced builder carry out this work, as the sides support the inner flues of the chimney. If the height is too low, remove the lintel and replace it at the required height.
- Step 2.** Check that your chimney is clean and free from obstructions. From the measurements taken select the size of your Jetmaster.
- Step 3.** Any cracks or cavities in the recess must be repaired and sealed.
- Step 4.** Tape the insulation to the back and sides of the Jetmaster, and slide it into place.
- Note 1. Do not recess unit by more than 110mm.  
 Note 2. Do not have exhaust openings at top of unit obstructed.  
 Note 3. Do not have air intake at bottom of unit obstructed.
- Step 5.** It is a good idea to light a fire at this stage, to check that all is well.
- Step 6.** Seal the unit into position with either silicone, a metal flange, or masonry. Allow masonry work to dry for minimum of three days before lighting the fire.

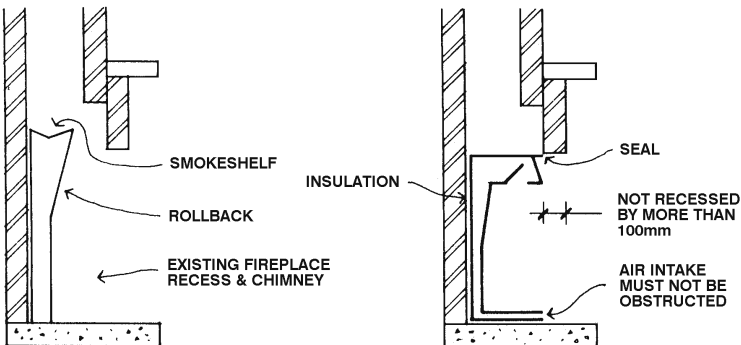

## OPEN WOOD JETMASTER - Minimum Flue Height

**Flue Termination**  
 The minimum flue length is 3.5 metres or above the ridge line (which ever is greater).

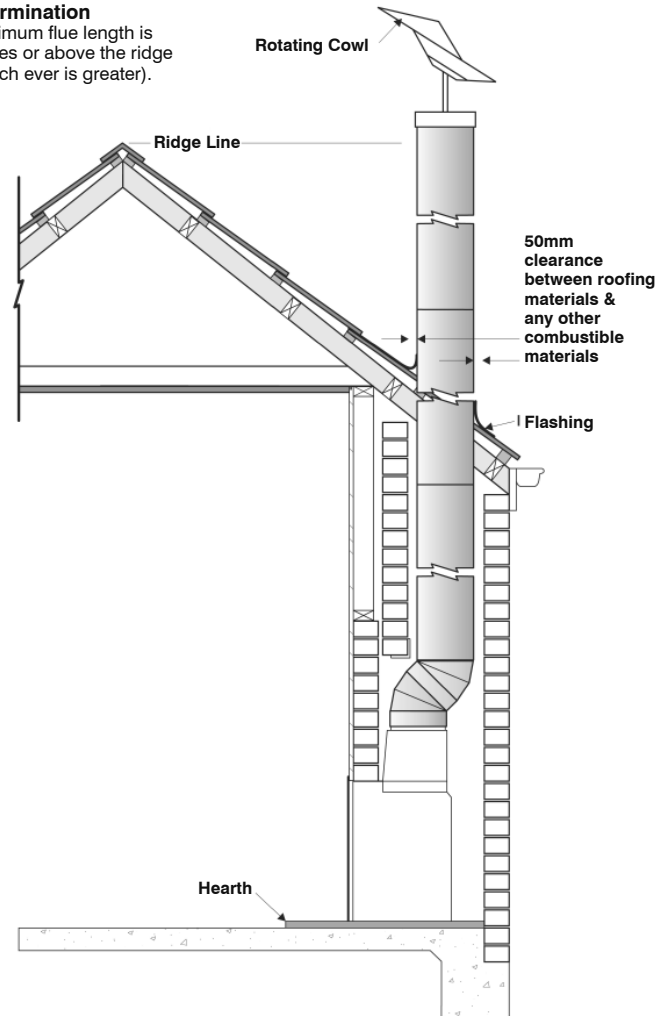

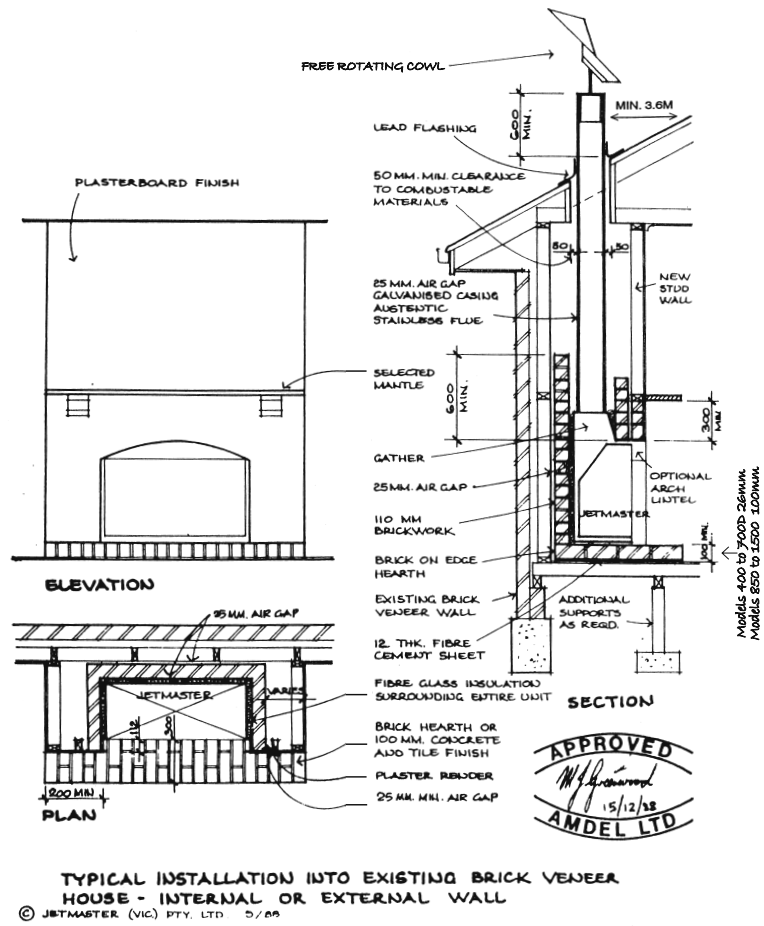
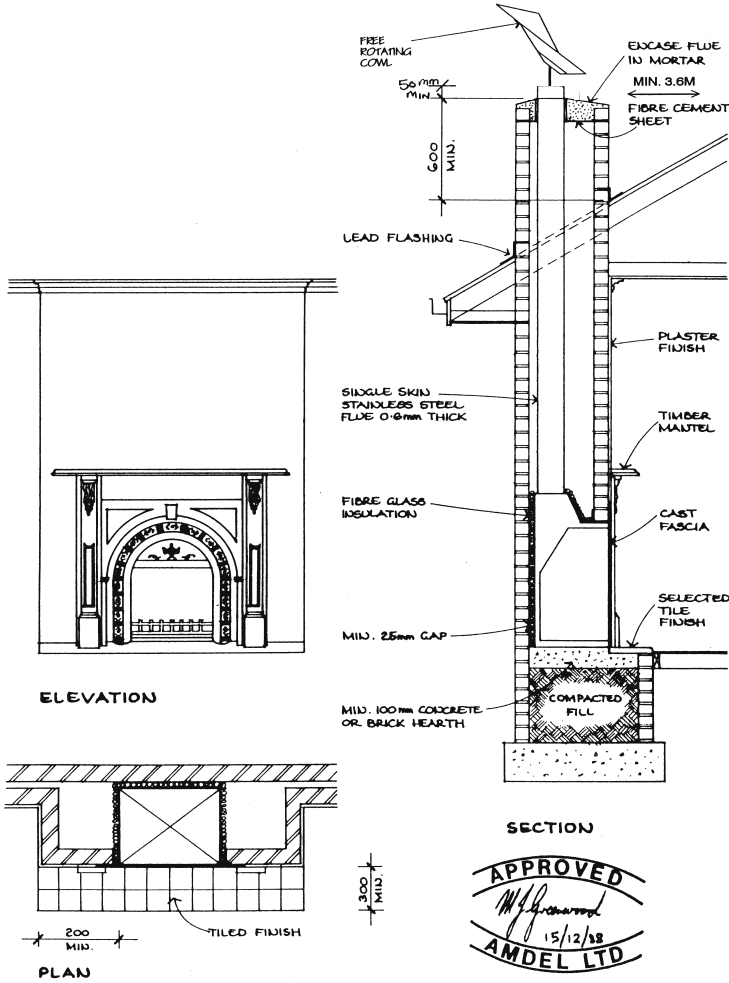

TYPICAL INSTALLATION INTO EXISTING BRICK VENEER HOUSE - INTERNAL OR EXTERNAL WALL

© JETMASTER (VIC) PTY. LTD 5/88

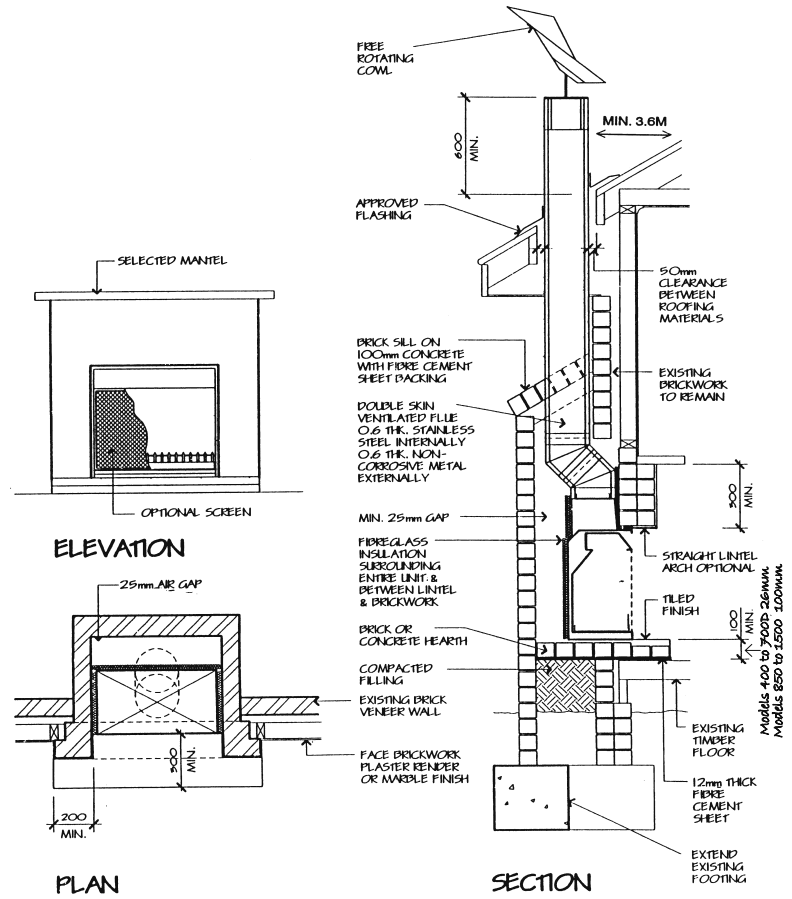
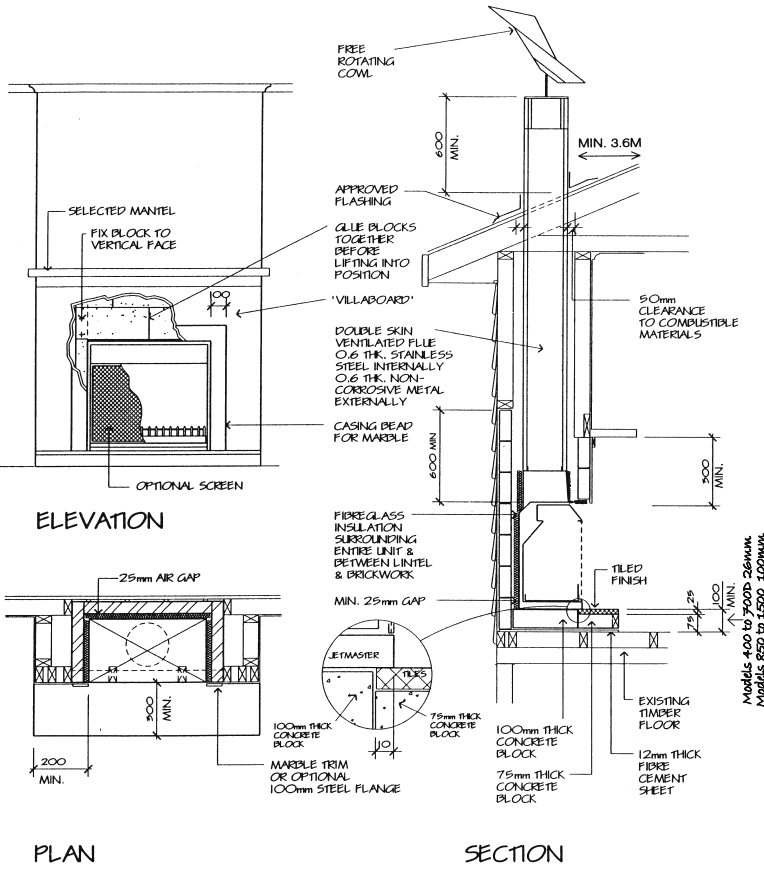

Construction Specifications - Jetmaster Traditional Edwardian On Stud Wall

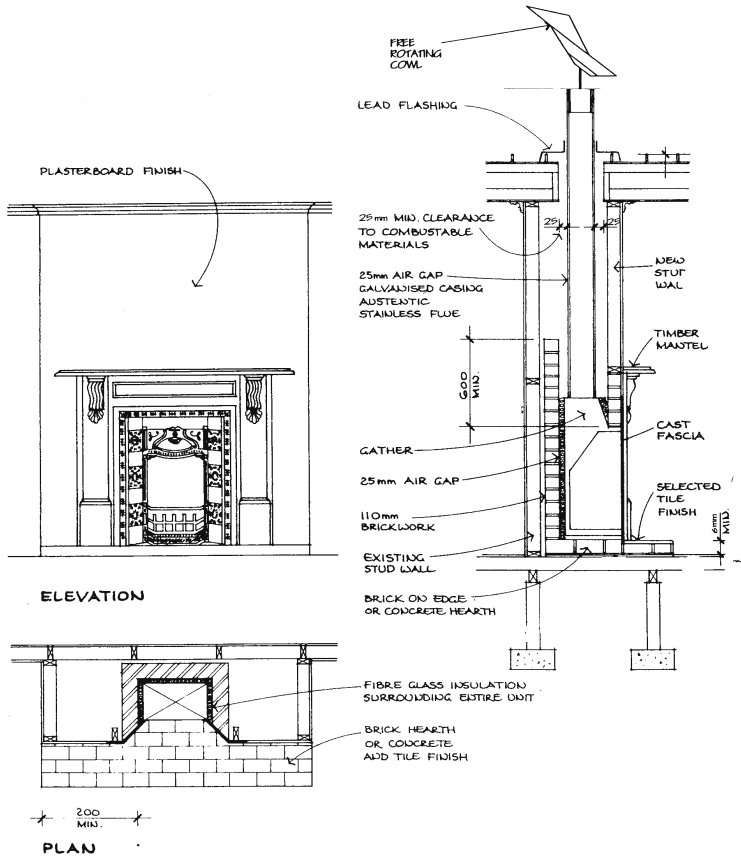

Construction Specifications - Jetmaster Free Standing Metal Casing "A"

Typical installation with exposed "flue" and/or one length heat shield, refer to deco mesh diagram for firebox and flue clearances to combustibles.

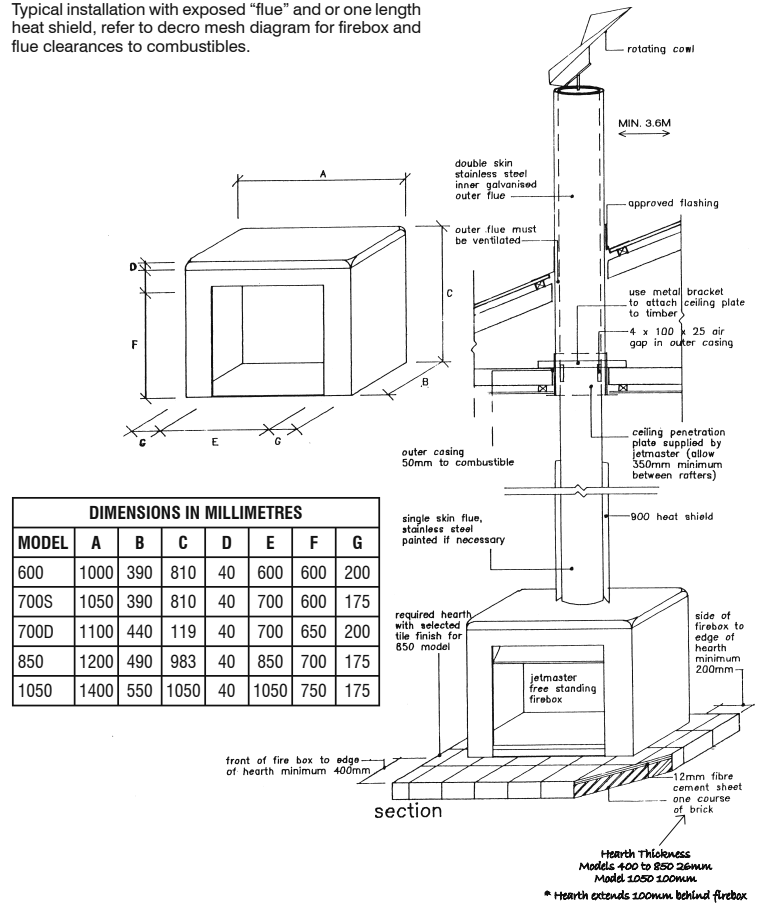

DIMENSIONS IN MILLIMETRES							
MODEL	A	B	C	D	E	F	G
600	1000	390	810	40	600	600	200
700S	1050	390	810	40	700	600	175
700D	1100	440	119	40	700	650	200
850	1200	490	983	40	850	700	175
1050	1400	550	1050	40	1050	750	175

Typical installation with deco mesh heat shield to ceiling.

FIREBOX AND FLUE CLEARANCES TO COMBUSTIBLES			
Jetmaster 600, 700S, 700D & 850 Freestanding			
	A	B	C
Flue Pipe	250	175	50
Flue Pipe with 900 Heat Shield	100	175	50
Flue Pipe with Decro Mesh	100	175	50

NOTE: min. 400mm from front of firebox to edge of hearth

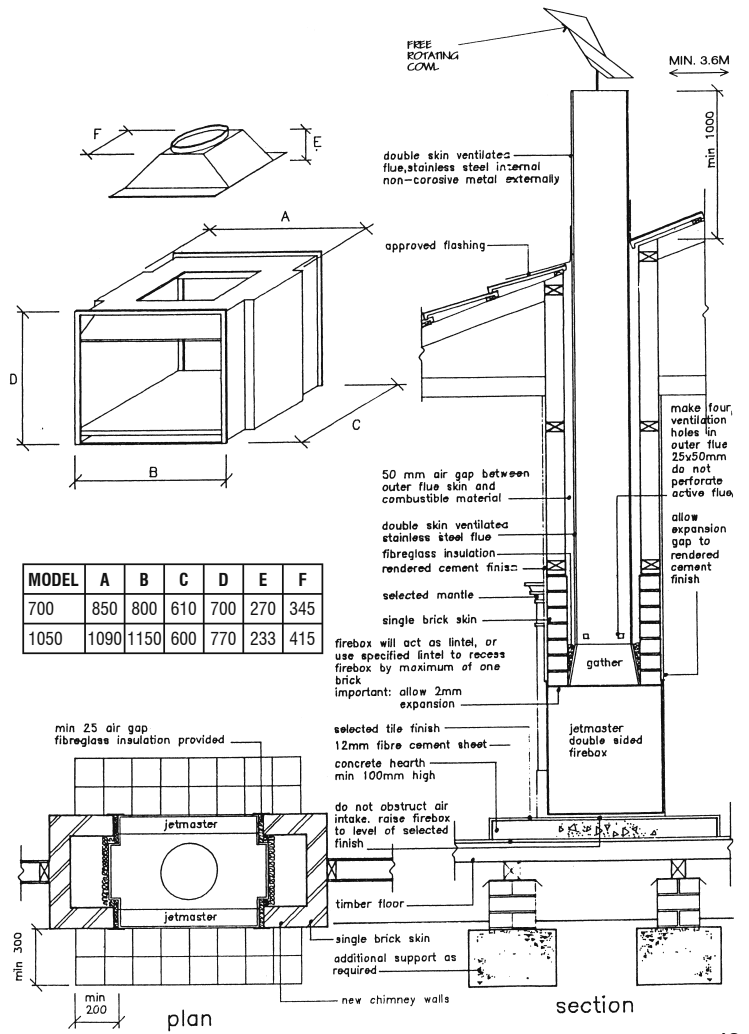
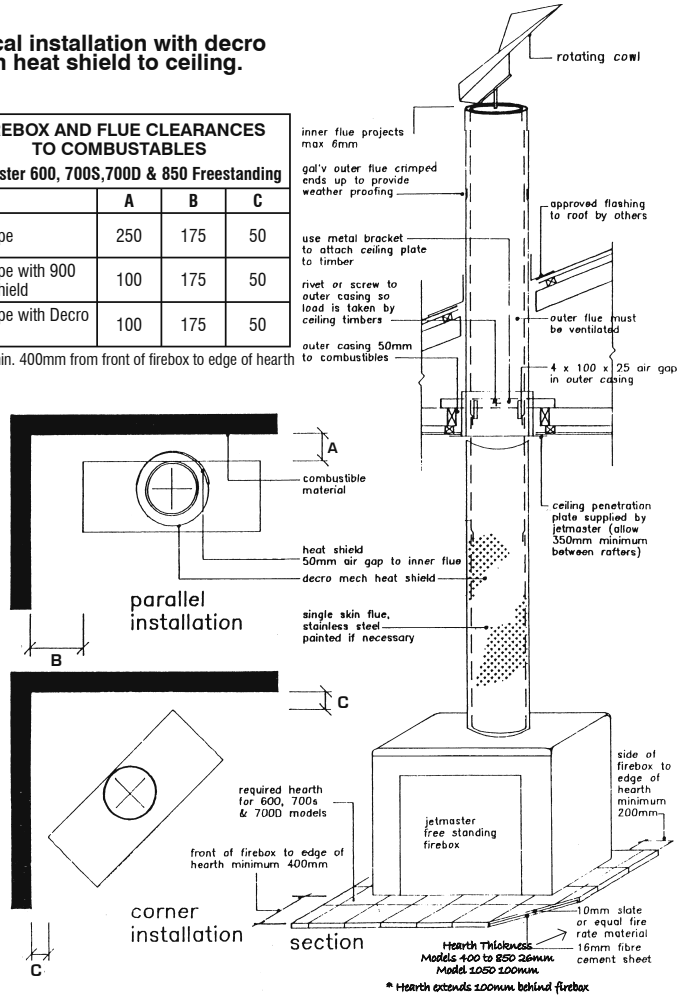



**Jetmaster Gas Open Fireplaces**

- Refer to the relevant specification in "Wood Fires" section of this manual.
- An approved gas cowl must be fitted to the top of the flue or chimney.
- All open gas fires require fixed fresh vents in the room. See next page for ventilation requirements.
- **Air movement systems** A decorative gas log fire must not be installed where the operation of any ventilation system, fan or air blower could under any circumstances cause the air pressure to be less than atmospheric at the appliance, or otherwise adversely affect the operation of the appliance.
- Do not block or restrict chimney or flue opening.
- After installing the appliance, check that the chimney/flue system draws well.
- Jetmaster recommends that all gas fires be serviced every 2 years.
- All gas units must be fitted by a licensed gas fitter.
- It is the responsibility of the gas fitter to follow the regulations set out in the Gas Code that dictate the procedures to follow when installing a gas appliance, particularly regarding gas pipe sizing and checking of pressures. (see summary page)
- For installation of the gas burner, see instruction manual supplied with gas burner.

**ROOMS WITH GAS OPEN FIRES  
REQUIRE FRESH AIR VENTS  
AS PER GAS REGULATIONS**

**For Example:**

**1 OFF: WOODFLOW VENT:**

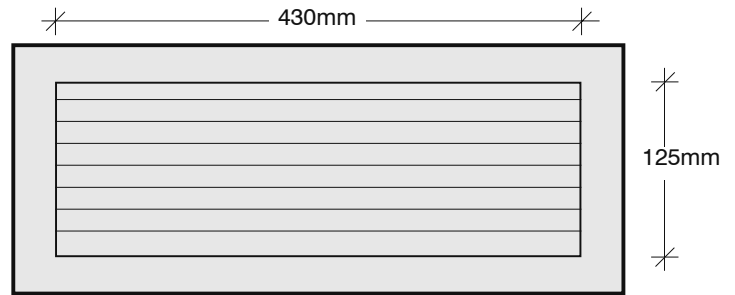

**Or:**

**2 OFF VENTS REQUIRED:**



**IMPORTANT - PLEASE NOTE**

**Failure of the gas fitter to install the appliance as per manufacturer's specifications and in line with the Gas Code will invalidate the warranty.**

**Flue Termination**

The Flue Terminal shall be located so that wind from any direction is not likely to create a downdraught in the flue. A Flue Cowl, AGA approved to AS4566 (AG604) must be fitted to the end of the flue pipe. The minimum flue length must not be shorter than 3.5 metres. Maintain a minimum of 500mm from the bottom of the flue cowl to the nearest part of the roof if the flue cowl is at least 1m from a neighbouring structure. If less than 1m, the flue terminal must be located at least 500mm above that structure. Refer to AS5601 - 2004 (AG601) sections 5.13.6.2 and 5.13.6.4 to ensure that the location of the flue terminal fully complies for installations with a trafficable roof, a chimney, another flue terminal or near any openings into a building.

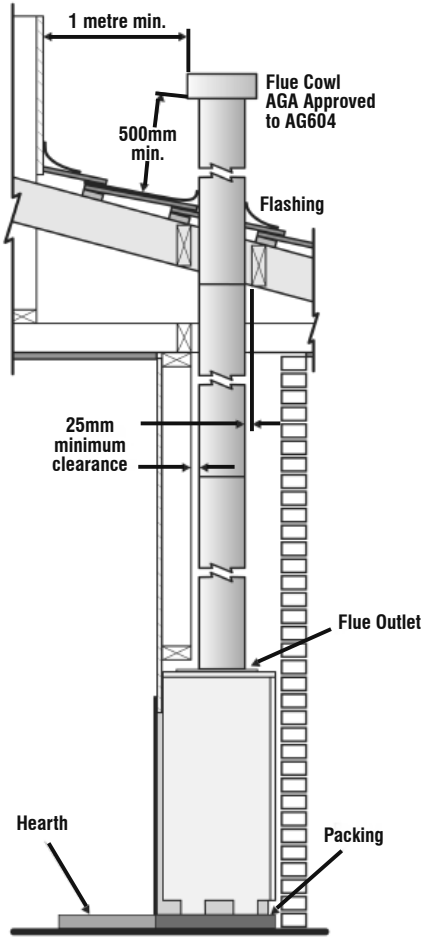

**HOW TO SET GAS PRESSURES**

**PRESSURE ADJUSTMENT FOR CAMPFYRE LOG  
GRL-24, GRL-700, GRL-830, GRL-850**

It is critical that all gas products be properly installed. Proper installation must include:

1. Vent configuration in line with requirements stated in manual.
2. Vent cap/terminal meets all clearance stated in manual.
3. Gas pressure is checked and adjusted at the time of installation.

**Note:** Pressures must be checked and adjusted to the correct specified pressure otherwise warranty will be invalid.

The pressure is measured on the gas valve and the regulator can be adjusted by turning the screws on the gas valve located either side of the pressure test points. (Refer to diagram in installation manual).

If the gas pressure is not checked it can lead to "sooting", "delayed ignition" or performance issues. Proper gas outlet pressure ensures that the fireplace is operating within the standards it was tested.

Ensure that the gas pressure does not change when other gas appliances in the home are activated. If the "inlet" pressure into the gas fireplace was to change when other appliances are activated this will cause the pilot flame to reduce in size, drop the millivolt output and possibly cause the unit to shut down.

Reminder: The inlet pressure of the gas fireplace is an unregulated pressure. Only the outlet pressure is held by the regulator located on the front of the gas valve.

Once installation is complete, it is imperative to do a smoke test to ensure that the gas fumes are consistently drawn up the flue.

\* This page does not take the place of the manual for each individual product, but is merely stressing the above points. Always read and understand the manual prior to installing any fireplace product.

*Thank you for ensuring that our products are installed and operated safely.*

Pressure "taps" are located at the face of the valve. There are two taps, one marked "IN" and the other marked "OUT".

- To check gas pressure simply turn the brass screw located in the "OUT" tap counter clockwise several turns.
- Hook up a manometer tube to the "OUT" tap.
- Turn the fireplace on and turn the flame adjustment (if applicable) to high. The outlet pressure should be set to the pressure stated on the compliance plate on the floor of the unit.
- Turn the fireplace off.
- Remove manometer tube from "OUT" tap.
- Tighten the screw by turning clockwise until snug.
- Soap water test to check for gas leaks.

## OPEN GAS JETMASTER

### PRESSURE ADJUSTMENT FOR IRONBARK, STANDARD COAL, TOPAZ & DELUXE LOGS & COALS

Put manometer onto test nipple on regulator and adjust regulator to 1 kpa with burner on high.

### PRESSURE ADJUSTMENT FOR SUPERCOAL

- Test point for outlet pressure is located on the on the left of the gas valve.
- Adjust to pressure stated on compliance plate.
- Check unit on low setting.

### SUMMARY TAKEN FROM THE GAS INSTALLATIONS AUSTRALIAN STANDARDS AS5601-2002 AG601-2002

**IMPORTANT: THIS IS A SUMMARY ONLY. THE GAS FITTER MUST REFER TO THE GAS INSTALLATIONS AUSTRALIAN STANDARDS IN DETAIL.**

#### Appendix F Sizing Consumer Piping

- **New Consumer Piping Systems**  
When sizing a new consumer piping system, consideration should be given to foreseeable future needs.
- **Existing Consumer Piping Systems**  
When an additional appliance is to be connected to an existing consumer piping system, the existing piping, metre and regulator should be checked to ensure that adequate capacity is available for the additional load.
- **Information Required Prior To Pipe Sizing**  
The following information is required prior to pipe sizing:
  - a. The type of gas, including the heating value and relative density.
  - b. The gas consumption of each appliance.
  - c. An allowance, if any, where there is a probability that not all appliances will be used at the same time.
  - d. The pressure available at the start of the consumer piping.
  - e. The allowable pressure drop shall be such as to ensure that at least the minimum inlet pressure required by the appliance is available at the appliance.
  - f. The proposed layout of the consumer piping system including all pipe lengths and the location of each appliance.

**NOTE:** See tables in this appendix

## OPERATING AND MAINTENANCE INSTRUCTIONS

Your JETMASTER fireplace is designed not to smoke and by following a few instructions you will achieve optimum heat output, convenience and fuel economy.

**Please note that the first fire could result in a few odours coming from the firebox. Do not be alarmed. This is not unusual when first using a metal finished product and will soon cease.**

### LIGHTING A FIRE

1. Using a number of crumpled sheets of newspaper, some kindling and a few small split logs arrange your fire in a "Teepee tent" style.
2. With the tool provided, fully open the DAMPER by pulling the control lever towards you. (Not always applicable with Double Sided Firebox.)
3. Light the fire at both ends as well as at the centre.
4. When the kindling and small split logs are burning well, start to build up your fire with larger **split logs**.
5. When the fire is well established you can start closing the Damper. The amount you can close it will depend on the type of wood used and the general weather conditions. Experience will soon show you how far; however, the damper should never be closed more than half way.
6. When the fire has gone out completely, you can close the Damper fully thus preventing any loss of heat from the room up the chimney.

### CLEANING

1. The Jetmaster Log Pan is designed to give greater heat and fuel efficiency. For the duration of the cold season **the Log Pan should never be emptied**. The resulting bed of ash and coals from previous fires will soon become a heatbank generating more heat than the burning logs. This ashbed also insulates and greatly extends the life of the Log Pan. This is why an ashbed must be maintained at all times.  
When the level of the ashbed becomes too high, the top layer can be removed. Depending on frequency of use and quality of wood, this skimming procedure should not be required more than once or twice a Season!
2. To prevent chimney fires as well as enabling the chimney to draw properly, the chimney/flue should be swept at least once a season, subject to the quality of timber used in the fire.

## OPERATING AND MAINTENANCE INSTRUCTIONS

### General Maintenance

The visible parts of your Jetmaster can be cleaned with a damp cloth or soft brush. Should you wish you could repaint the unit with a heat resistant paint.

### Safety

The Jetmaster is a safety-tested unit. However, you must never leave an open fire unguarded. Jetmaster has a screen that is designed to prevent sparks leaving the fireplace and very resistant to being accidentally knocked over by young children.

### Fuels

1. Medium density woods are preferred for open fireplaces. Softer woods (Pines etc) burn fast, leaving a lot of ash and creosote. Hard woods (Red Gum etc) can be best used when mixed with medium woods and should not be used to start a fire.
2. A split log will burn better than a full log.
3. Wood should be stored (seasoned) in a dry ventilated area for at least 12 months. "Green" wood can have 50% moisture, which results in a very poor heat emission. Box woods (e.g. Grey Box and Yellow Box) are highly recommended as they produce fine coals.

***Burning well seasoned medium density wood is the most important step towards achieving optimum results from your JETMASTER!***

## HOW TO FIT FASCIAS

1. Use lugs and bolts provided and attach to flange on firebox.  
**OR**
2. Use masonry plugs and drill through corners of fascia and attach to bricks.  
**OR**
3. If neither of the above is suitable, then use heat resistance bonding silicon.

**Note:** Mantelpiece will hold fascia in position.

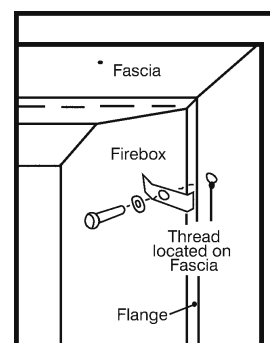

### 100mm Stainless Steel Trim Method for Attachment

1. Score the back of the stainless steel trim and the surface to which the trim will be attached, to allow the two surfaces to adhere well to each other.
2. Place a bead of Silicone onto the back of the stainless steel trim.
3. Place another bead of Liquid Nails around the outer edge of the frame. This will cure quickly and hold the frame into position.
4. Clamp the trim onto the unit for 24 hours until the adhesives have cured.

---