

DDL-5550N-7 DDL-5550-7 INSTRUCTION MANUAL

Congratulations on your purchase of a JUKI sewing machine. Please read this Instruction Manual carefully before using the unit in order to get the most out of it and to enjoy using it for a long time.

BEFORE OPERATION

1. Never operate the machine unless its oil pan has been filled with oil.
2. After setting up the machine, check the direction of motor rotation. To check it, turn the handwheel by hand to bring the needle down, and turn the power switch ON while observing the handwheel. (The handwheel should turn counterclockwise as observed from the handwheel side.)
3. Run the sewing machine at a speed of 4,000s.p.m. or less for the first one month.
4. Confirm that the voltage and phase (single- or 3-phase) are correct by checking them against the ratings shown on the motor nameplate.

OPERATION PRECAUTIONS

1. Keep your hands away from the needle when you turn the power switch ON or while the machine is operating.
2. Do not put your fingers into the thread take-up cover while the machine is operating.
3. Be sure to turn the power switch OFF before tilting the machine head or removing the V belt.
4. When an operator leaves from the machine, make sure to turn off the power.
5. During operation, be careful not to allow your or any other person's head or hands to come close to the handwheel, V belt, bobbin winder or motor. Also, do not place anything close to them. Doing so may be dangerous.
6. If your machine is provided with a belt cover, finger guard or any other protectors, do not operate your machine with any of them removed.

1. INSTALLATION

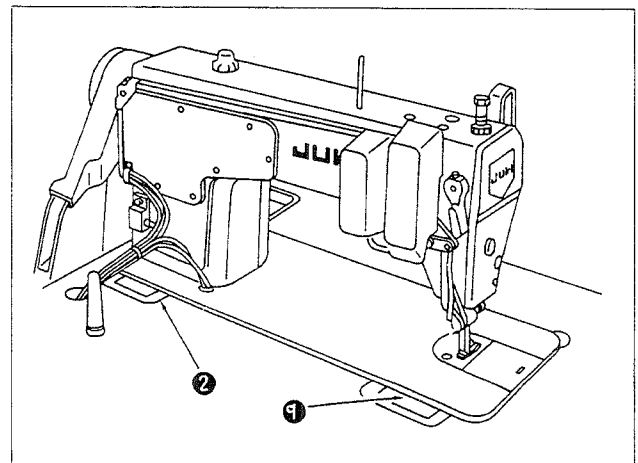
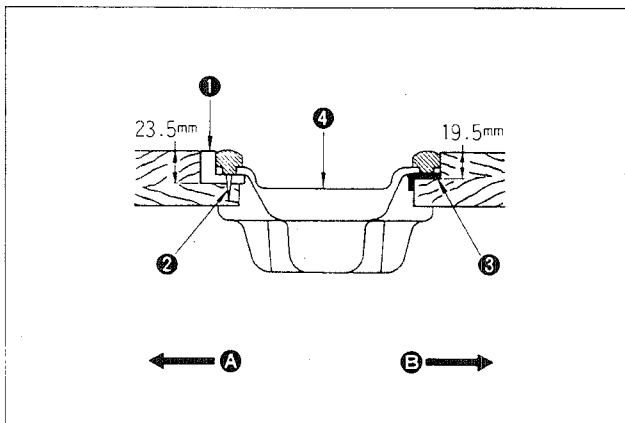
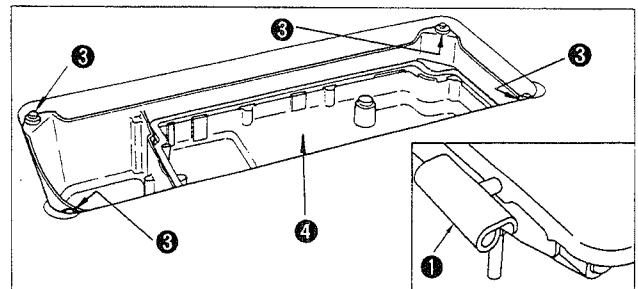
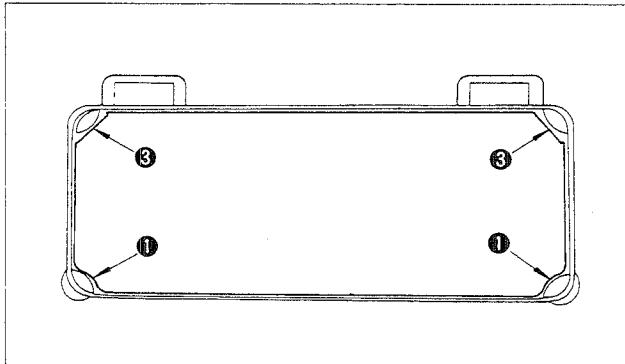

1. Installing the oil pan

- 1) The oil pan should rest on the four corners of the machine table groove.
- 2) Fix two rubber seats ① on side A (operator's side) using nails ② as illustrated above. Fix two cushion seats ③ on side B (hinged side) using a rubber-based adhesive. Then place oil pan ④ on the fixed seats.

- 1) Fit hinge ① into the opening in the machine bed, and fit the machine head to table rubber hinge ② before placing the machine head on cushions ③ on the four corners.

2. LUBRICATION

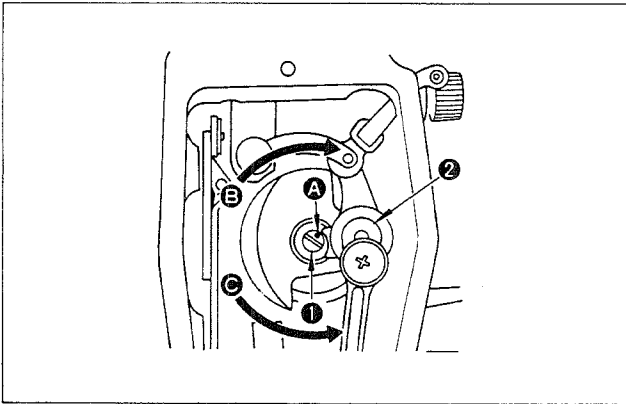
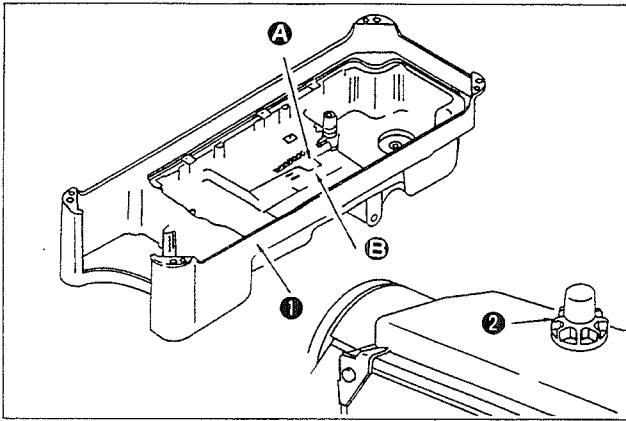

1. Information on lubrication

- 1) Fill oil pan ① with JUKI New Defrix Oil No. 1 up to HIGH mark ②.
- 2) When the oil level lowers below LOW mark ③, refill the oil pan with the specified oil.
- 3) When you operate the machine after lubrication, you will see splashing oil through oil sight window ④ if the lubrication is adequate.
- 4) Note that the amount of the splashing oil is unrelated to the amount of the lubricating oil.

(Precaution) When you first operate your machine after setup or after an extended period of disuse, run your machine at 3,000s.p.m. to 3,500 s.p.m. for about 10 minutes for the purpose of break-in.

2. Adjusting the amount of oil supplied to the face plate parts

- 1) Adjust the amount of oil supplied to the thread take-up and needle bar crank ② by turning adjust pin ①.
- 2) The minimum amount of oil is reached when marker dot ④ is brought close to needle bar crank ② by turning the adjust pin in direction ⑤.
- 3) The maximum amount of oil is reached when marker dot ④ is brought to the position just opposite from the needle bar crank by turning the adjust pin in direction ⑥.

3. ADJUSTING THE AMOUNT OF OIL (OIL SPLASHES) IN THE HOOK

① Amount of oil (oil splashes) confirmation paper

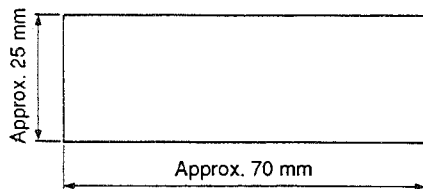

* Use any paper available regardless of the material. (Rough paper will do.)

② Position to confirm the amount of oil (oil splashes)

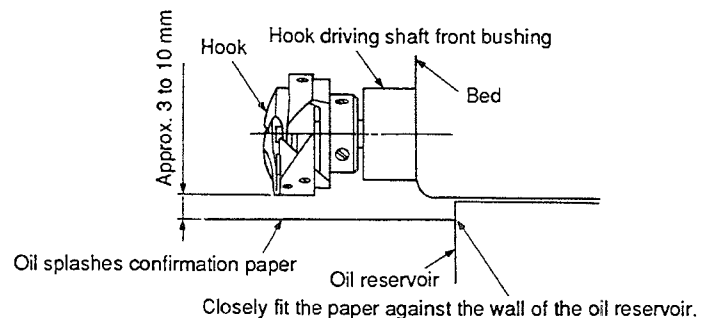

* Place the amount of oil (oil splashes) confirmation paper under the hook.

- 1) If the machine has not been sufficiently warmed up for operation, make the machine run idle for approximately three minutes. (Moderate intermittent operation)
- 2) Place the amount of oil (oil splashes) confirmation paper under the hook while the sewing machine is in operation.
- 3) Confirm that the height of the oil surface in the oil reservoir is within the range between "HI" and "LOW."
- 4) Confirmation of the amount of oil should be completed in five seconds. (Check the period of time with a watch.)

● Sample showing the appropriate amount of oil

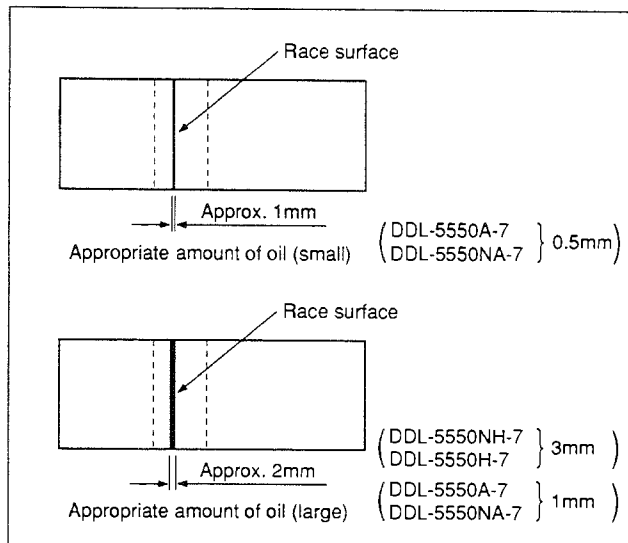

- 1) The amount of oil shown in the samples on the left should be finely adjusted in accordance with sewing processes. Be careful not to excessively increase/decrease the amount of oil in the hook. (If the amount of oil is too small, the hook will be seized (the hook will be hot). If the amount of oil is too much, the sewing product may be stained with oil.)
- 2) Confirm the amount of oil (oil splashes) with three sheets of the confirmation paper on the premise that the amount of oil (oil splashes) on the respective three sheets of paper do not change.

● Adjusting the amount of oil (oil splashes) in the hook

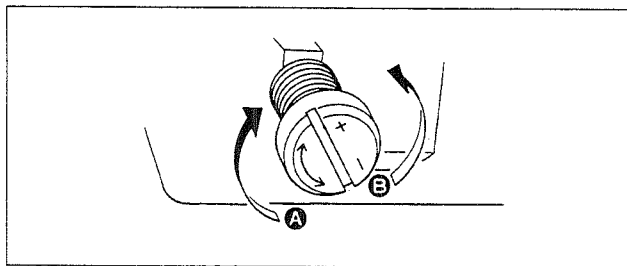

- 1) Turning the oil amount adjustment screw mounted on the hook driving shaft front bushing in the "+" direction (in direction A) will increase the amount of oil (oil splashes) in the hook, or in the "-" direction (in direction B) will decrease it.
- 2) After the amount of oil in the hook has been properly adjusted with the oil amount adjustment screw, make the sewing machine run idle for approximately 30 seconds to check the amount of oil (oil splashes) in the hook.

4. ATTACHING THE NEEDLE

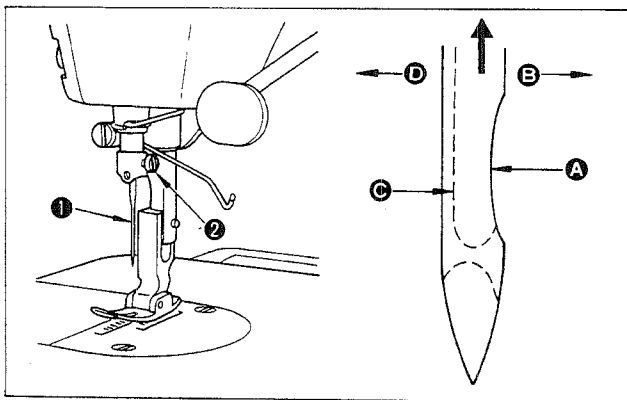

● Turn the motor power OFF before starting to attach the needle.

A needle of DB × 1 (DA × 1 for DDL-5550A-7, -5550NA-7) should be used. Select a proper needle size according to the count of thread and the type of material used.

- 1) Turn the handwheel until the needle bar reaches the highest point of its stroke.
- 2) Loosen screw ②, and hold needle ① with its indented part A facing exactly to the right in direction B.
- 3) Insert the needle in the direction of the arrow until it will go no further.
- 4) Securely tighten screw ②.
- 5) Check that long groove C of the needle is facing exactly to the left in direction D.

5. SETTING THE BOBBIN INTO THE BOBBIN CASE

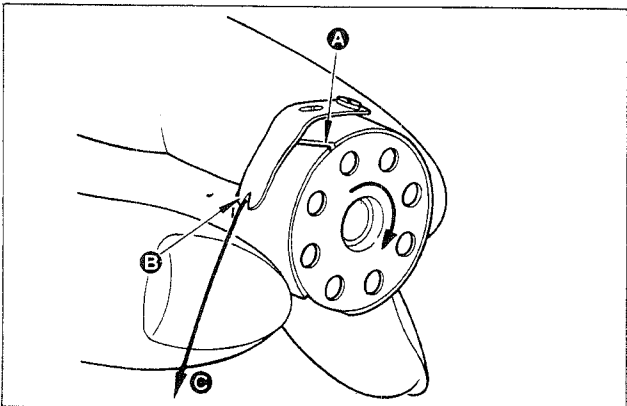

- 1) Hold the bobbin in a way that the thread open end is directed to the right as observed from you, and set the bobbin into the bobbin case.
- 2) Pass the thread through thread slit A, and pull the thread in direction B. By so doing, the thread will pass under the tension spring and come out from notch B.
- 3) Check that the bobbin rotates in the direction of the arrow when thread C is pulled.

6. THREADING THE MACHINE HEAD

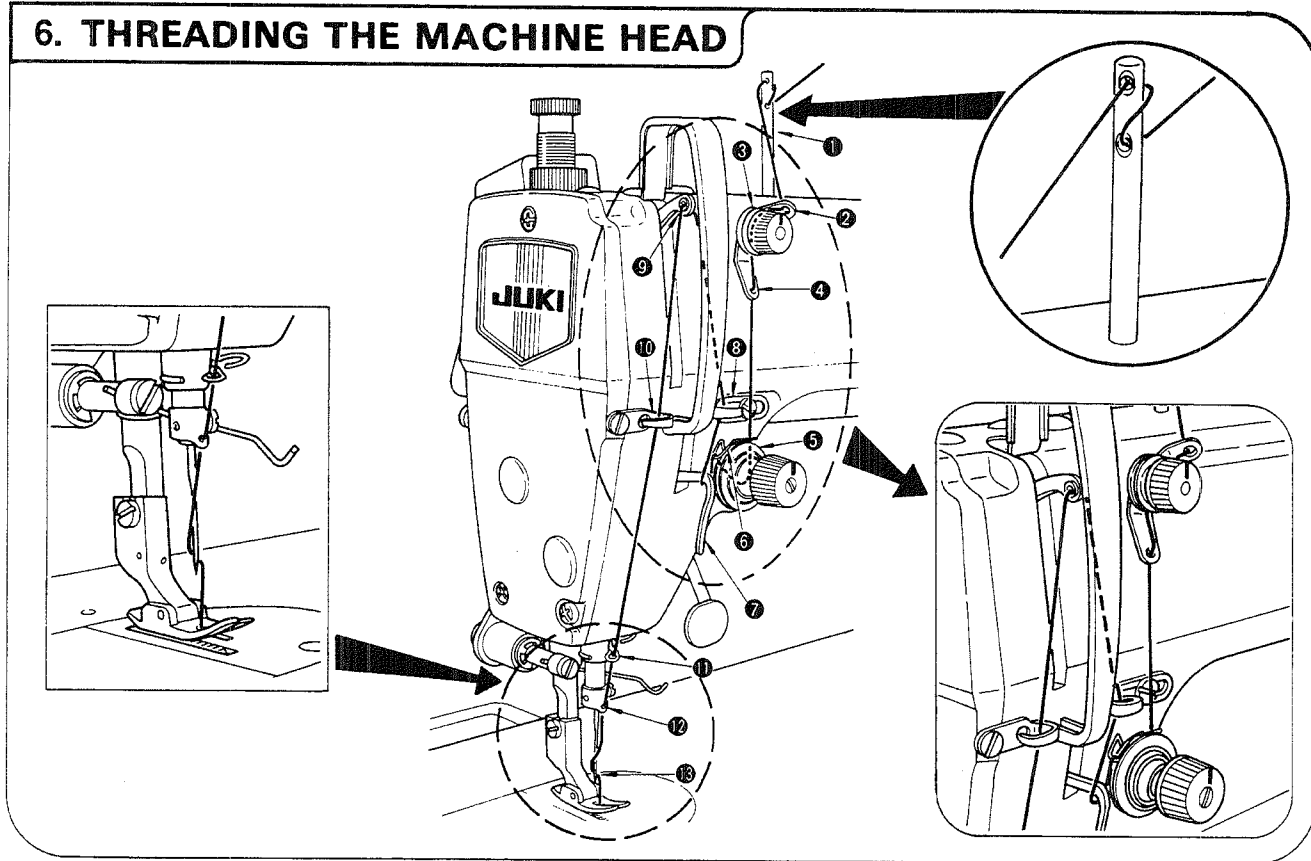

7. ADJUSTING THE STITCH LENGTH

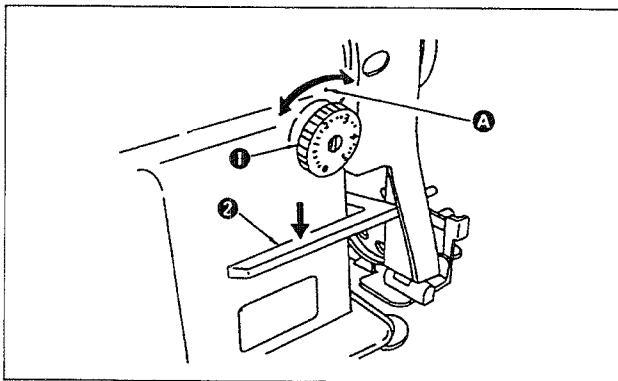

- 1) Turn stitch length dial ① in the direction of the arrow, and align the desired number to marker dot A on the machine arm.
- 2) The dial calibration is in millimeters.
- 3) When you want to decrease the stitch length, turn stitch length dial ① while pressing feed lever ② in the direction of the arrow.

8. INSTALLING THE THREAD STAND

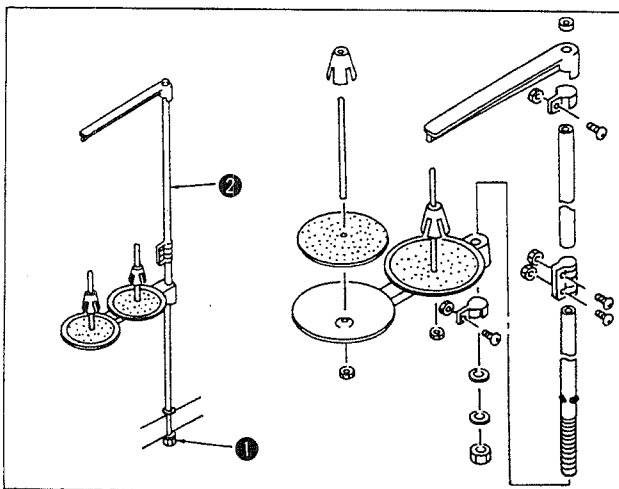

- 1) Assemble the thread stand unit, and insert it in the hole in the machine table.
- 2) Tighten locknut ① to fix the thread stand.
- 3) For ceiling wiring, pass the power cord through spool rest rod ②.

9. INSTALLING THE BELT COVER AND THE BOBBIN WINDER

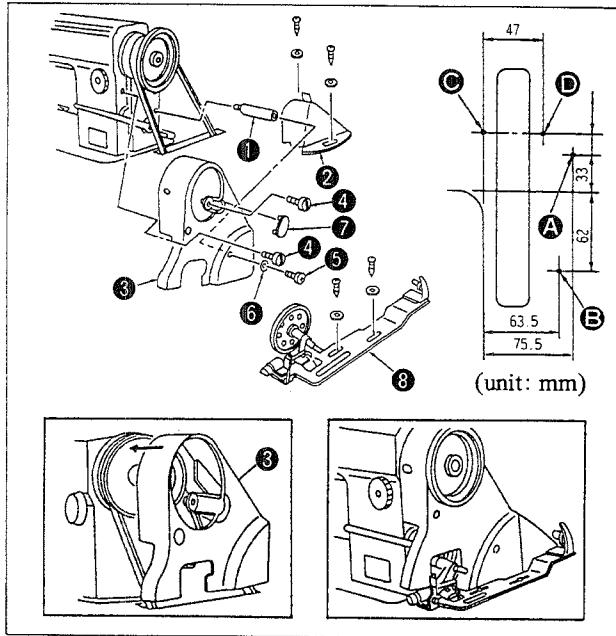

How to install the belt cover and the bobbin winder

1. Installation procedure

- 1) Drill four guiding holes **A**, **B**, **C** and **D** for wooden screws in the table.
- 2) Install belt cover support **1** in the tapped hole in the arm.
- 3) Pass the handwheel through the hole in belt cover **A** **3**, then set the handwheel on the arm. At this time, you can smoothly install the handwheel diagonally from the rear of the handwheel by tilting belt cover **A** **3** as illustrated in the figure.
- 4) Place belt cover **B** **2** on guiding holes **C** and **D**.
- 5) Fix belt cover **A** **3** on the arm using screws **4**, **5** and washer **6**. At this time, tighten screw **4** with a tightening torque of 30 kgf/cm and screw **5** with a tightening torque of 25 kgf/cm. If you tighten further these screws, the securing state of the belt cover will not change.
- 6) Fit cat **7** to the belt cover **A**.
- 7) Move belt cover **B** **2** backward until the rubber section of belt cover **B** **2** comes in contact with belt cover **A** **3**. Then, further move the belt cover **B** in the same direction by 0.5 to 1 mm. Now, fix the belt cover **B** in position using wooden screw and washer.
- 8) Fix bobbin winder **8** in guiding holes **A** and **B** using wooden screws and washers.

10. ADJUSTING THE HEIGHT OF THE KNEE LIFTER

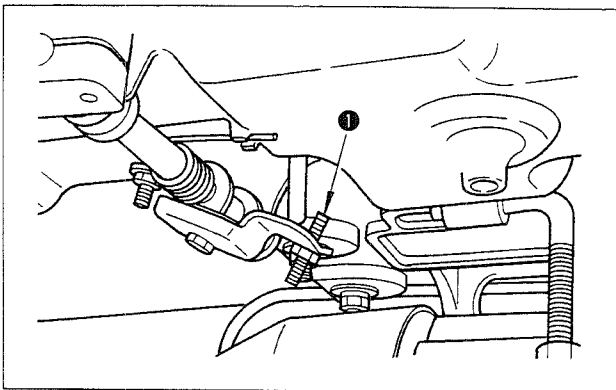

- 1) The standard height of the presser foot lifted using the knee lifter is 10 mm.
- 2) You can adjust the presser foot lift up to 13 mm using knee lifter adjust screw **1**. (The max. lift should be 9 mm for the A type.)
- 3) When you have adjusted the presser foot lift to over 10 mm, be sure that the bottom end of needle bar **2** in its lowest position does not hit presser foot **3**.

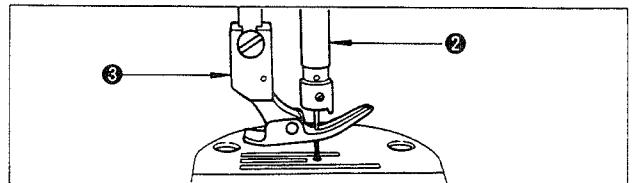

11. PEDAL OPERATION

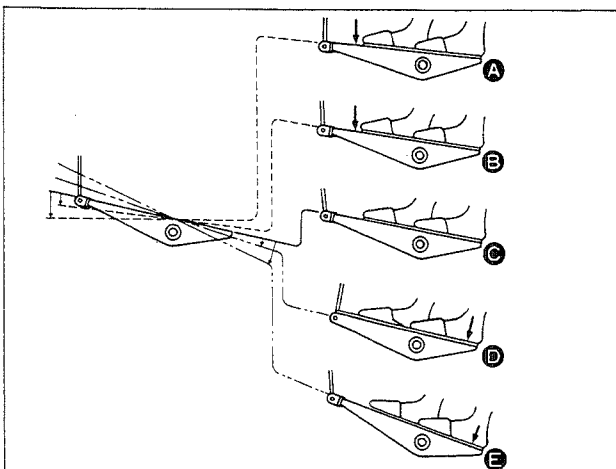

1. The pedal is operated in the following four steps:

- 1) The machine runs at low sewing speed when you lightly depress the front part of the pedal. **E**
- 2) The machine runs at high sewing speed when you further depress the front part of the pedal. **A** (If the automatic reverse feed stitching has been preset, the machine runs at high speed after it completes reverse feed stitching.)
- 3) The machine stops (with its needle up or down) when you reset the pedal to its original position. **C**
- 4) The machine trims threads when you fully depress the back part of the pedal. **E**

* If your machine is provided with the Auto-lifter (AK-85), an addition step is given between the machine stop and thread trimming step.

The presser foot goes up when you lightly depress the back part of the pedal **D**, and if you further depress the back part, the thread trimmer is actuated.

- The machine will completely perform thread trimming even if you reset the pedal to its neutral position immediately after the machine started thread trimming action.
- When the machine stops with its needle down, and if you want to bring the needle up, depress the back part of the pedal once.

- If you reset the pedal to its neutral position during the automatic reverse feed stitching at seam start, the machine stops after it completes the reverse feed stitching.
- The machine will perform normal thread trimming even if you depress the back part of the pedal immediately following high or low speed sewing.

12. THREAD TENSION

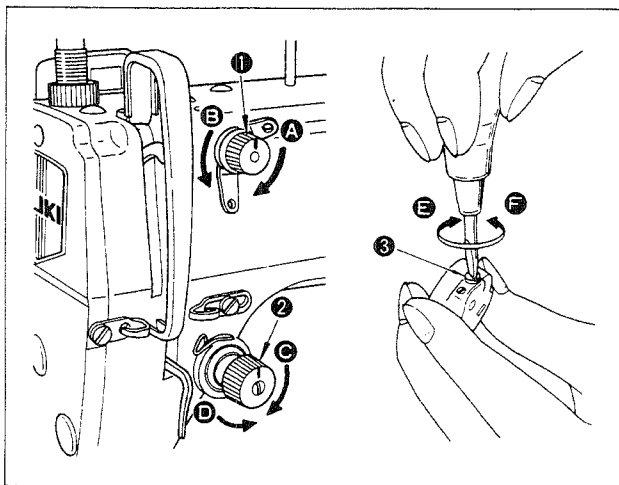

1. Adjusting the needle thread tension

- 1) As you turn thread tension No. 1 nut ① clockwise (in direction A), the thread remaining on the needle after thread trimming will be shorter.
- 2) As you turn nut ① counterclockwise (in direction B), the thread length will be longer.
- 3) As you turn thread tension No. 2 nut ② clockwise (in direction C), the needle thread tension will be increased.
- 4) As you turn nut ② counterclockwise (in direction D), the needle thread tension will be decreased.

2. Adjusting the bobbin thread tension

- 1) As you turn tension adjust screw ③ clockwise (in direction E), the bobbin thread tension will be increased.
- 2) As you turn screw ③ counterclockwise (in direction F), the bobbin thread tension will be decreased.

13. THREAD TAKE-UP SPRING

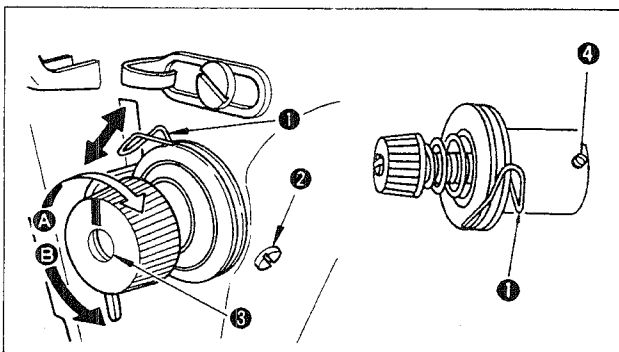

1. Changing the stroke of thread take-up spring ①

- 1) Loosen setscrew ②.
- 2) As you turn tension post ③ clockwise (in direction A), the stroke of the thread take-up spring will be increased.
- 3) As you turn the knob counterclockwise (in direction B), the stroke will be decreased.

2. Changing the pressure of thread take-up spring ①

- 1) Loosen setscrew ②, and remove tension post ③.
- 2) Loosen setscrew ④.
- 3) As you turn tension post ⑤ clockwise (in direction A), the pressure will be increased.
- 4) As you turn the post counterclockwise (in direction B), the pressure will be decreased.

14. HAND LIFTER

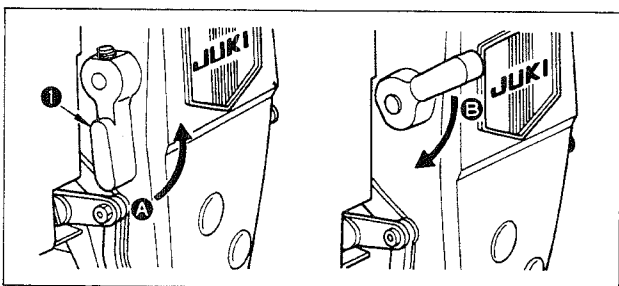

- 1) To stop the machine with its presser foot up, turn hand lifter ① in direction A.
- 2) The presser foot will go up about 5.5 mm (4 mm for A type) and stop.
- 3) The presser foot will go back to its original position when hand lifter is turned down in direction B.
- 4) Using the knee lifter, you can get the standard presser foot lift of about 10 mm and the maximum lift of about 13 mm (max. 9 mm for A type).

15. PRESSER FOOT PRESSURE

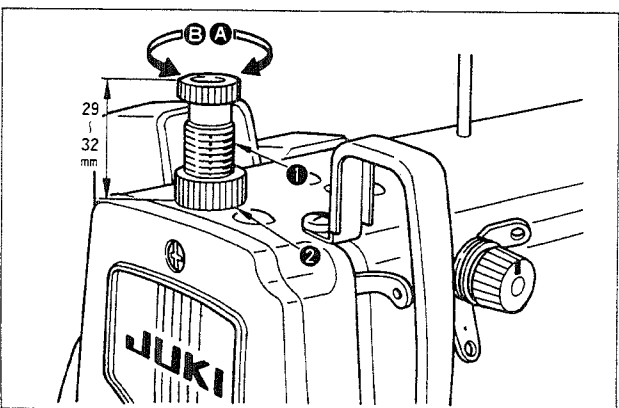

- 1) Loosen nut ②. As you turn presser spring regulator ① clockwise (in direction A), the presser foot pressure will be increased.
- 2) As you turn the presser spring regulator counterclockwise (in direction B), the pressure will be decreased.
- 3) After adjustment, tighten nut ②.
- 4) For general fabrics, the standard height of the presser spring regulator is 29 to 32 mm (5kg) (7 kg for DDL-5550H-7, and -5550NH-7)

16. ADJUSTING THE FEED TIMING

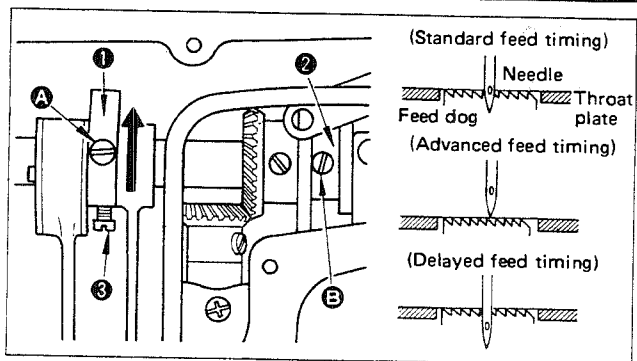

- 1) To obtain the standard feed timing, align setscrew **A** on feed eccentric cam **1** with setscrew **B** on main shaft thrust collar **2**.
- 2) To make adjustment, loosen two setscrews **C** to release the feed eccentric cam. Then retighten the setscrews.
- 3) To advance the feed timing in order to prevent uneven material feed, move the feed eccentric cam in the direction of the arrow.
- 4) To delay the feed timing in order to increase stitch tightness, move the feed eccentric cam in the opposite direction from the arrow.
- 5) Be careful not to move the feed eccentric cam too far, or else needle breakage may result.

17. TILT OF THE FEED DOG

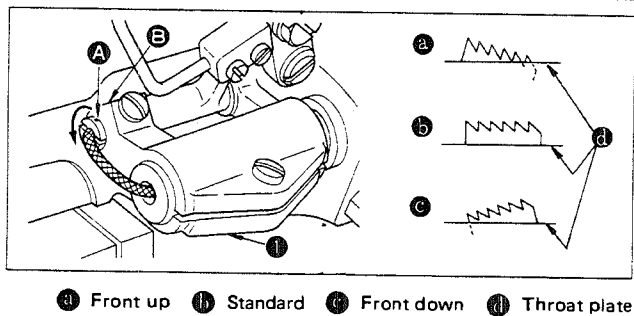

- 1) The standard tilt (horizontal) of the feed dog is obtained when marker dot **A** on the feed bar shaft is aligned with marker dot **B** on feed rocker **1**.
(The standard tilt for DDL-5550H-7, 5550NH-7 of the feed dog is obtained when marker dot **A** is aligned with center of feed rocker shaft.)
- 2) To tilt the feed dog with its front up in order to prevent puckering, loosen the setscrew, and turn the feed bar shaft 90 degrees in the direction of the arrow, using a screwdriver.
- 3) To tilt the feed dog with its front down in order to prevent uneven material feed, turn the feed bar shaft 90 degrees in the opposite direction from the arrow.
(The standard tilt for DDL-5550H-7, NH-7)

(Precaution) Whenever the feed dog tilt is adjusted, the feed dog height will be changed. So, it is necessary to check the feed dog height after tilt adjustment.

18. HEIGHT OF THE FEED DOG

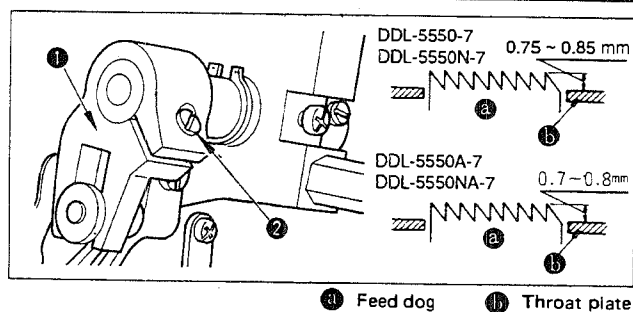

- 1) The feed dog is factory-adjusted so that it just out from the throat plate surface 0.75 to 0.85 mm (1.15 to 1.25 mm for DDL-5550H-7, 5550NH-7, 0.7 to 0.8 mm for DDL-5550A-7, DDL-5550NA-7).
- 2) If the feed dog just out too much, puckering may result when sewing light-weight materials. (Recommended protrusion: 0.7 to 0.8 mm)
- 3) To adjust the height of the feed dog:
 - ① Loosen screw **2** of crank **1**.
 - ② Move the feed bar up or down to make adjustment.
 - ③ Securely tighten screw **2**.

19. NEEDLE-TO-HOOK RELATIONSHIP

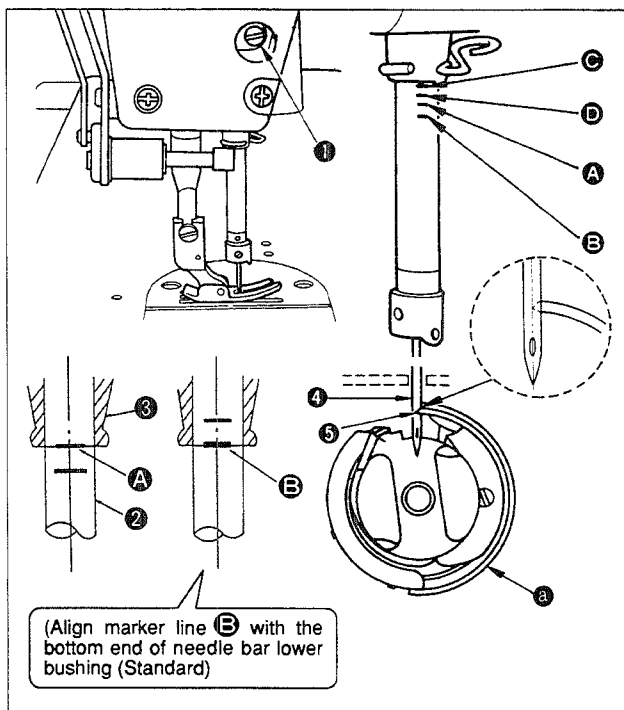

1. Adjust the timing between the needle and the hook as follows:

- 1) Turn the handwheel to bring the needle bar down to the lowest point of its stroke, and loosen setscrew ①. (Adjusting the needle bar height)
- 2) (For a DB needle) Align marker line A on needle bar ② with the bottom end of needle bar lower bushing ③, then tighten setscrew ①. (For a DA needle) Align marker line C on needle bar ② with the bottom end of needle bar lower bushing ③, then tighten setscrew ①. (Adjusting position ④ of the hook)
- 3) (For a DB needle) Loosen the three hook setscrews, turn the handwheel, and align marker line B on ascending needle bar ② with the bottom end of needle bar lower bushing ③. (For a DA needle) Loosen the three hook setscrews, turn the handwheel, and align marker line D on ascending needle bar ② with the bottom end of needle bar lower bushing ③.
- 4) After making the adjustments mentioned in the above steps, align hook blade point ⑤ with the center of needle ④. Provide a clearance of 0.04 mm to 0.1 mm between the needle and the hook, then securely tighten the hook setscrews.

* When replacing the hook, specify its part No. 11141355 (11092251 for DDL-5550H-7 and DDL-5550NH-7).

20. ADJUSTING THE HEIGHT OF THE PRESSER BAR

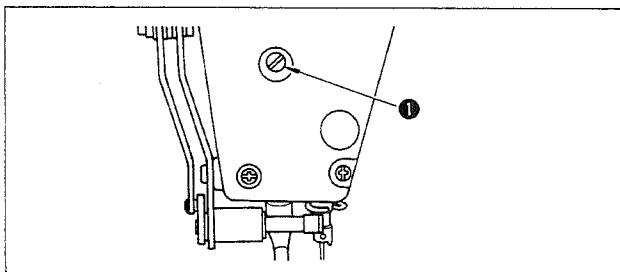

- 1) Loosen setscrew ①, and adjust the presser bar height or the angle of the presser foot.
- 2) After adjustment, securely tighten the setscrew.

21. COUNTER KNIFE

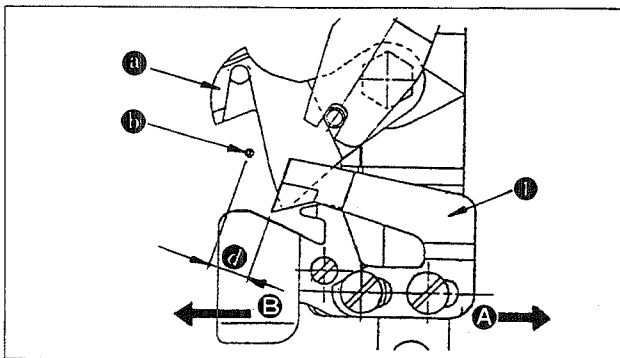

DDL-5550H-7, DDL-5550NH-7

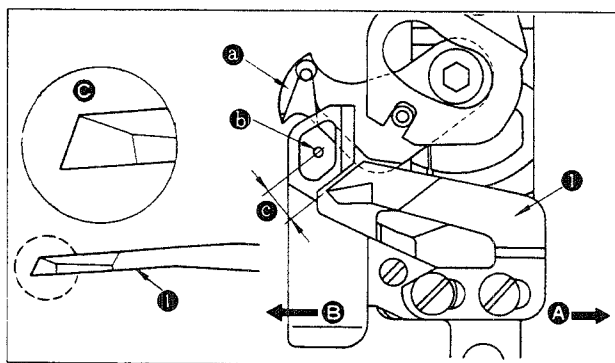

DDL-5550-7, DDL-5550A-7, DDL-5550N-7, DDL-5550NA-7

1. When the knife sharpness has deteriorated, resharpen counter knife ① as illustrated in ③, and properly reinstall it.
- 1) If the mounting position of the counter knife is moved in direction A from the standard mounting position, the thread length after thread trimming will be increased accordingly.
- 2) If the mounting position is moved in direction B, the thread length will be decreased accordingly.

- ③ Moving knife
- ④ Center of needle
- ⑤ Standard : 4.0 mm (DDL-5550-7, DDL-5550A-7, DDL-5550N-7, DDL-5550NA-7)
- ⑥ Standard : 4.5 mm

22. ADJUSTING THE THREAD TAKE-UP STROKE

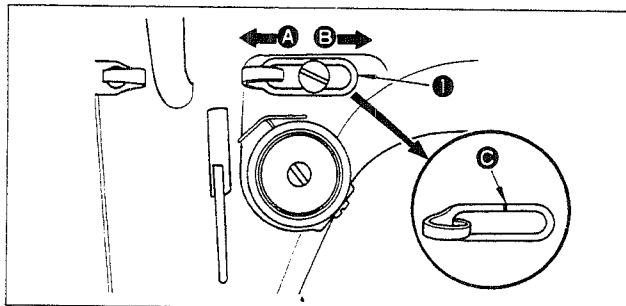

- 1) When sewing heavy-weight materials, move thread guide ① to the left (in direction A) to increase the length of thread pulled out by the thread take-up.
- 2) When sewing light-weight materials, move thread guide ① to the right (in direction B) to decrease the length of thread pulled out by the thread take-up.
- 3) Normally, thread guide ① is positioned in a way that marker line C is aligned with the center of the screw.

23. ADJUSTING THE NEEDLE STOP POSITION

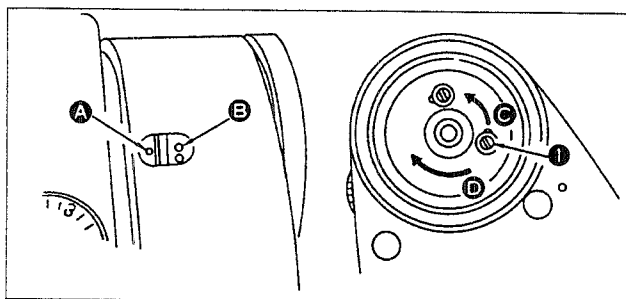

1. Stop position after thread trimming

- 1) The standard needle stop position is obtained by aligning red marker dot A on the machine arm with white marker dot B on the handwheel.
- 2) Stop the needle in its highest position, loosen screw ① to perform adjustment within the slot of the screw.
 - ① The needle stop timing is advanced if you move the screw in direction C.
 - ② The needle stop timing is delayed if you move the screw in direction D.

(Precaution) Do not operate the machine with screw ① loosened. Just loosen the screw, and do not remove it.

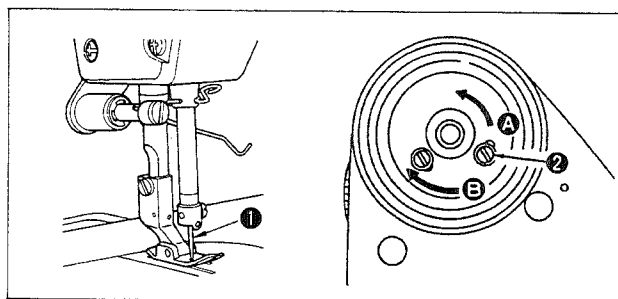

1. Lower stop position

- 1) The lower needle stop position when the pedal is returned to the neutral position after the front part of the pedal is depressed can be adjusted as follows: Stop needle ① in its lowest position, loosen screw ②, and make adjustment within the slot of the screw. Moving the screw in direction A advances the needle stop timing. Moving the screw in direction B delays the timing.

(Precaution) Do not operate the machine with screw ② loosened. Just loosen the screw, and do not remove it.

24. PEDAL PRESSURE AND PEDAL STROKE

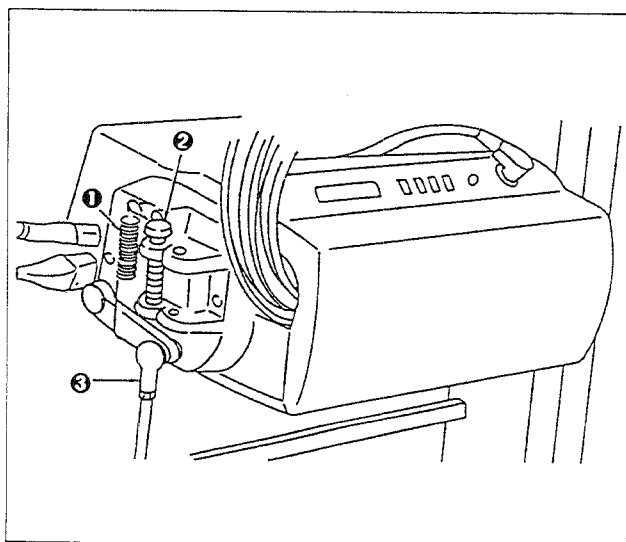

1. Adjusting the pressure required to depress the front part of the pedal

- 1) This pressure can be changed by altering the mounting position of pedaling pressure adjust spring ①.
- 2) The pressure decreases when you hook the spring on the left side.
- 3) The pressure increases when you hook the spring on the right side.

2. Adjusting the pressure required to depress the back part of the pedal

- 1) This pressure can be adjusted using regulator screw ②.
- 2) The pressure increases as you turn the regulator screw in.
- 3) The pressure decreases as you turn the screw out.

3. Adjusting the pedal stroke

- 1) The pedal stroke decreases when you insert connecting rod ③ into the left hole.

25. ADJUSTMENT OF THE PEDAL

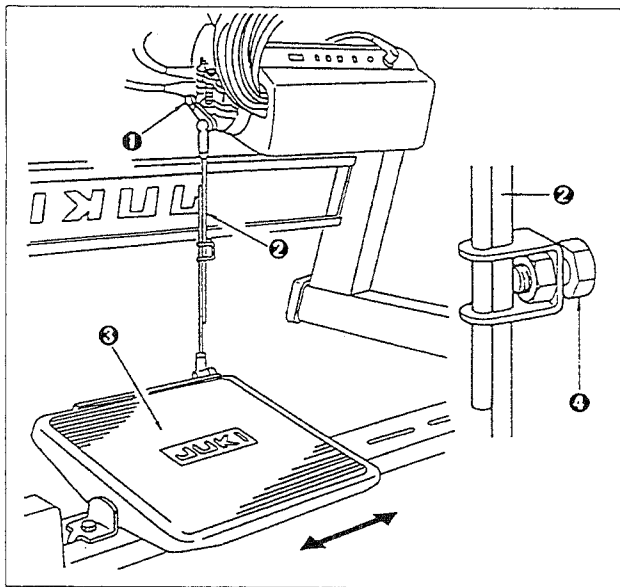

1. Installing the connecting rod

- 1) Move pedal ③ to the right or left as illustrated by the arrows so that motor control lever ① and connecting rod ② are straightened.

2. Adjusting the pedal angle

- 1) The pedal tilt can be freely adjusted by changing the length of the connecting rod.
- 2) Loosen adjust screw ④, and adjust the length of connecting rod ②.

26. ONE-TOUCH TYPE REVERSE FEED STITCHING MECHANISM

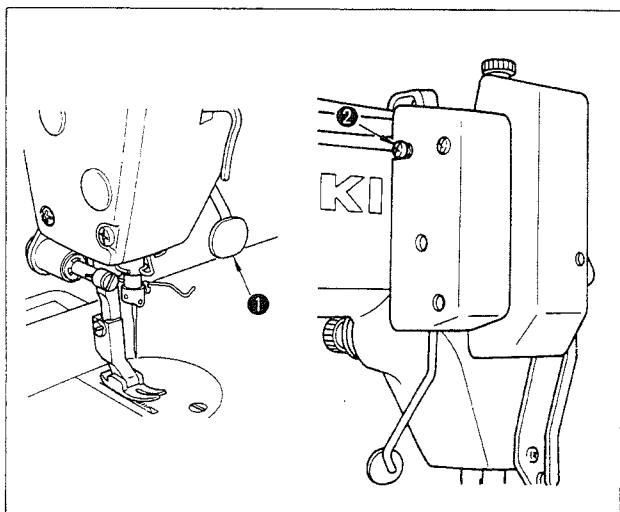

1. How to operate

- 1) The moment switch lever ① is pressed, the machine performs reverse feed stitching.
- 2) The machine performs reverse feed stitching as long as the switch lever is held depressed.
- 3) The machine resumes normal feed stitching the moment the switch lever is released.

2. Height of the switch lever

- 1) Adjust the height of switch lever ① so that it can be easily operated.
- 2) Loosen screw ②, and move the switch lever up or down to adjust its height.

27. WIPER (DDL-5550-7, DDL-5550A-7, DDL-5550H-7, DDL-5550N-7, DDL-5550NA-7, DDL-5550NH-7)

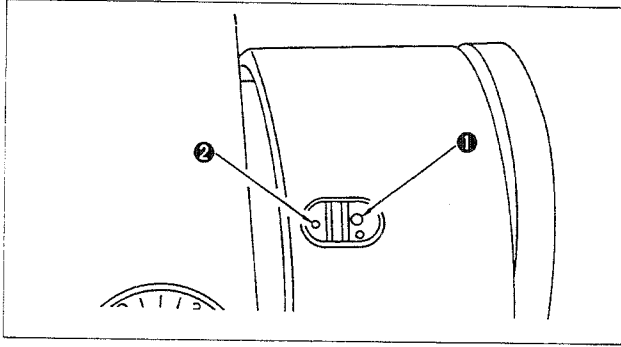

1. Positioning the wiper

Adjust the position of the wiper according to the thickness of the material sewn. The adjustment procedure is as follows:

- 1) Turn the handwheel in the normal direction of rotation to align white marker dot ① on the handwheel with red marker dot ② on the machine arm.

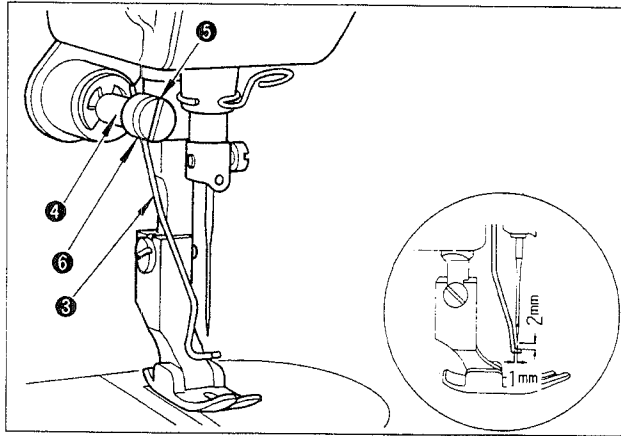

- 2) Adjust the distance between the flat part of the wiper and the center of the needle to 1 mm. Tighten wiper adjust screw ⑤ so that the wiper is pressed and fixed by wiper collar ⑥.

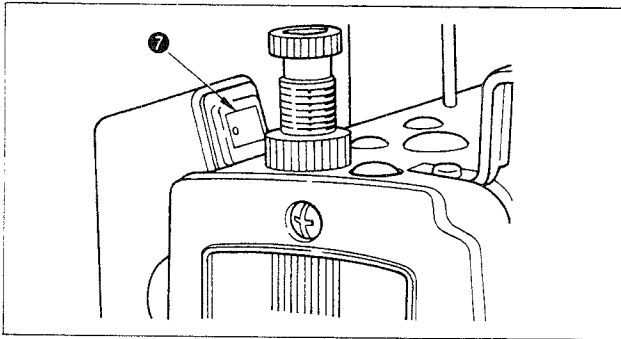

- 3) When the wiper is unnecessary, turn wiper switch ⑦ OFF.

28. SPECIFICATIONS

	DDL-5550-7 DDL-5550N-7	DDL-5550A-7 DDL-5550NA-7	DDL-5550H-7 DDL-5550NH-7
Application	General fabrics, light-weight materials and medium-weight materials	General fabrics and light-weight materials	Medium-weight materials and heavy-weight materials
Sewing speed	Max. 5,000 s.p.m.	Max. 4,000 s.p.m.	Max. 4,000 s.p.m.
Stitch length	Max. 4 mm		Max. 5 mm
Needle	DB x 1 #9 ~ 18	DA x 1 #9 ~ 11	DB x 1 #20 ~ 23
Presser foot lift (by knee lifter)	10mm (standard) 13mm(max.)	9 mm (max.)	10mm (standard) 13mm(max.)
Lubricating oil	Juki New Defrix Oil No. 1		

JUKI

JUKI CORPORATION

HEAD OFFICE
8-2-1 KOKURYO-CHO
CHOFU-CITY, TOKYO 182, JAPAN

BUSINESS OFFICE
1-23-3 KABUKI-CHO
SHINJUKU-KU, TOKYO 160, JAPAN
PHONE : 03(3205)1188, 1189, 1190
FAX : 03(3203)8260, (3205)9131
TELEX : J22967, 232-2301

To order or for further information, please contact :

Please do not hesitate to contact our distributors or agents in your area for further information when necessary.
*The description covered in this instruction manual is subject to change for improvement of the commodity without notice.