



Air-to-water Heat Pump Monobloc Versati

Design and Selection

GREE ELECTRIC APPLIANCES, INC.OF ZHUHAI

CONTENTS

1 Installation Example	1
2 Model Selection	3
2.1 Speculations of Power Supply	3
2.2 Operation Conditions	3
2.3 Flowchart of Model Selection	3
2.4 Design Principle	3
3 Selection of the Underfloor Coils	4
3.1 Calculation of Unit Load for Floor Heating	4
3.2 Selection of Tube Spacing of the Underfloor Coils.....	4
4 Quantity and Location of the Water Traps and Collectors.....	5
4.1 Design Requirements on Loop Quantity for Circulation Water.....	5
4.2 Requirements on Installation of the Water Trap (Collector)	6
5 Section of FCU	7
5.1 FCU Type Selection	7
5.2 Matching of Capacity.....	7
6 Selection of the Water Tank	8
6.1 Specifications of the Water Tank	8
6.2 Volume Selection of the Water Tank	8
7 Examples for Model Selection	8
7.1 General Introduction to the Example Project	8
7.2 Heat Load Calculation	9
7.3 Model Selection.....	10

1 Installation Example

CASE 1: Connecting Heat Emitters for Heating and Cooling(Under floor loop,Fan Coil Unit,and Radiator)

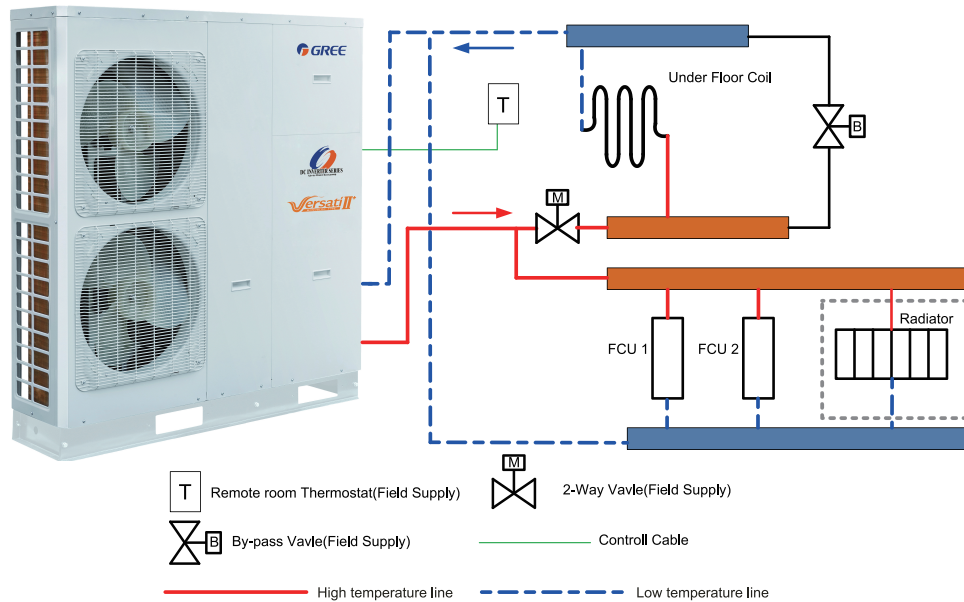

Notes

- ① The two-way valve is very important to prevent dew condensation on the floor and Radiator while cooling mode;
- ② Type of thermostat and specification should be complied with installation of this manual;
- ③ The Bypass valve must be installed to secure enough water flow rate, and should be installed at the collector.

CASE 2: Connecting Sanitary Water Tank

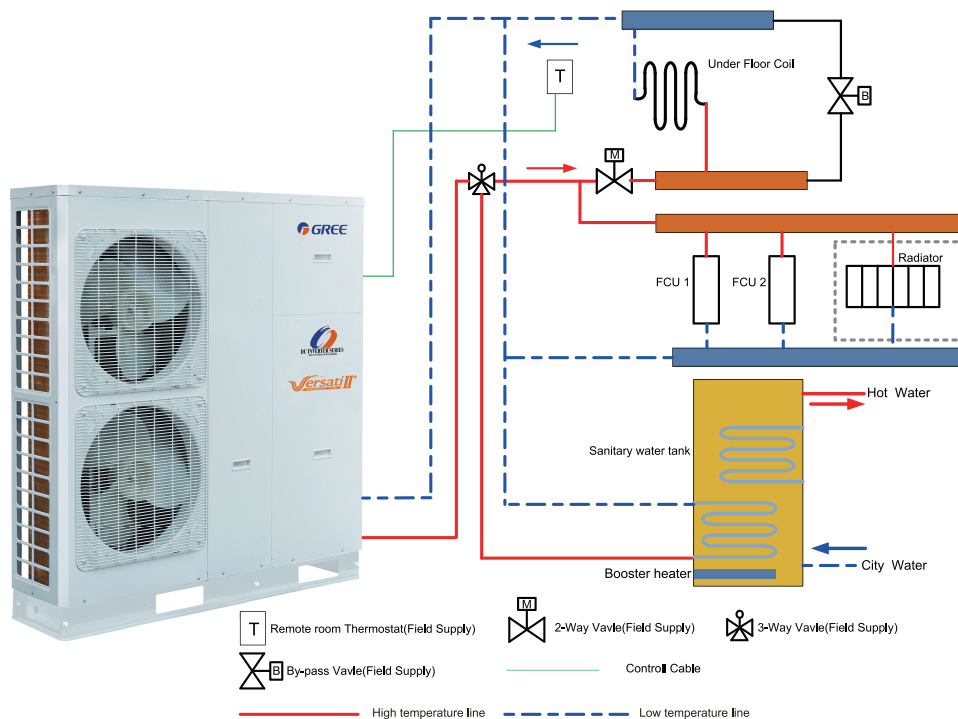

Notes

- ① In this case, three-way valve should be installed and should be complied with installation of this manual;
- ② Sanitary water tank should be equipped with internal electric heater to secure enough heat energy in the very cold days;

CASE 3 : Connecting Solar thermal system

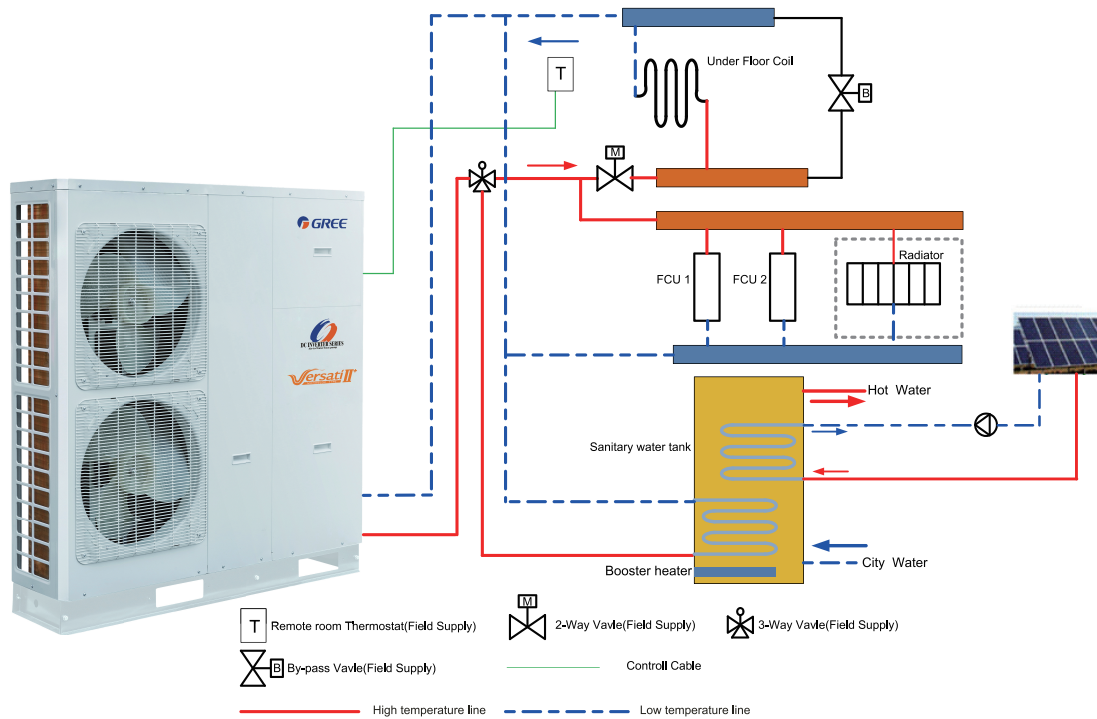

Two-way valve is very important to prevent dew condensation on the floor and Radiator while cooling mode.

CASE 4 : Connecting Swimming pool system

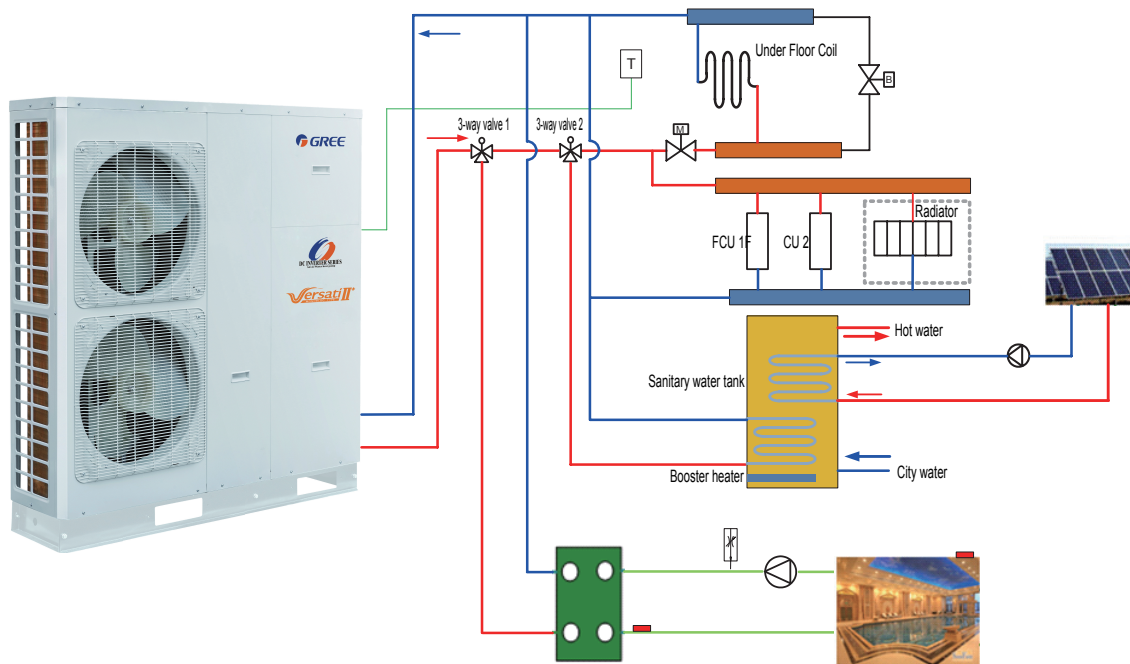

Notes:

- ① Two-way valve is very important to prevent dew condensation on the floor and Radiator while cooling mode.
- ② 3-Way valve 1 is controlled by user, while the pool pump is activated, 3-Way valve 1 switches to pool loop; while the pool pump is shut down, 3-Way valve 1 switches to under floor/FCU loop.
- ③ 3-Way valve 2 is automatic controlled by monobloc unit, while running water heating mode, 3-Way valve 2 switches to water tank loop; while running cooling/heating mode, 3-Way valve 2 switches to under floor/FCU loop.

2 Model Selection

2.1 Speculations of Power Supply

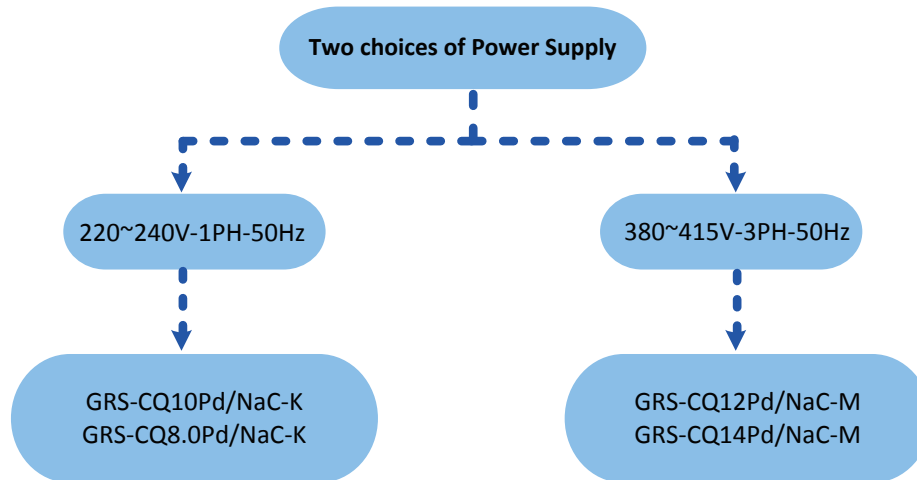

2.2 Operation Conditions

Capacities and power inputs are based on the following conditions (floor heating /cooling)	
a. Cooling conditions	b. Heating conditions
Indoor Water Temp 23°C/18°C;	Indoor Water Temp 30°C/35°C;
Outdoor Air Temp 35°C DB/24°C WB	Outdoor Air Temp 7°C DB/6°C WB
Capacities and power inputs are based on the following conditions (FCU or radiator)	
a. Cooling conditions	b. Heating conditions
Indoor Water Temp 12°C/7°C;	Indoor Water Temp 40°C/45°C;
Outdoor Air Temp 35°C DB/24°C WB	Outdoor Air Temp 7°C DB/6°C WB

2.3 Flowchart of Model Selection

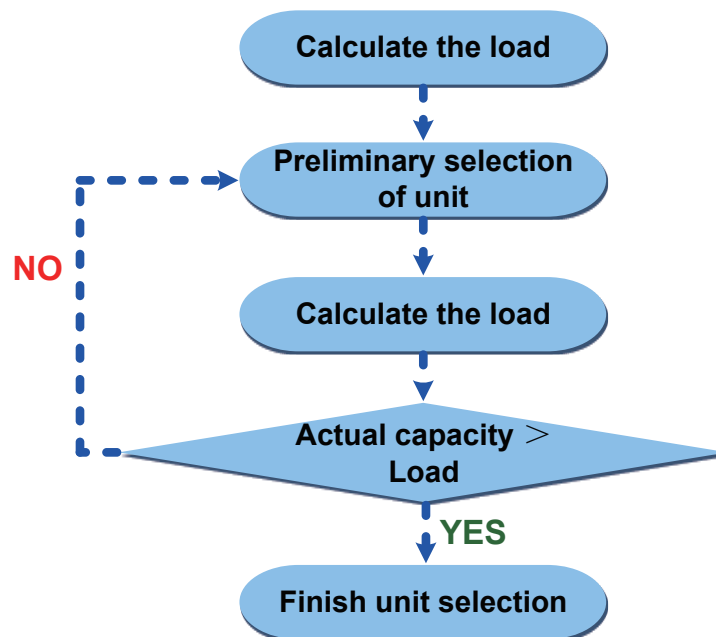

2.4 Design Principle

- ◆ Cooling: capacity of the unit \geq cooling load of the air conditioning
- ◆ Heating: capacity of the unit \geq max{ heating load, floor heating load, water heating load}
- ◆ Water Tank: it should be selected based on the sanitary outfit or quantity of users. Each unit can accommodate only one water tank.

3 Selection of the Underfloor Coils

3.1 Calculation of Unit Load for Floor Heating

Empirical Values of Floor Heating Load Per Square Meter

House W/m ²		
Dining Room		100~120
Mater Room		100~110
Guest Room		110~130
Study Room		90~110
Villa W/m ²		
Dining Room		110~140
Mater Room		100~120
Guest Room		100~130
Study Room		100~120

Notes

- ① Villas whose load is generally larger than the houses should take the value between the middle and the maximum empirical values listed above.
- ② The top lever whose load is generally larger than the middle or bottom layer should take the maximum empirical value.
- ③ The guest room whose load is generally much large should take the value between the intermediate and the maximum empirical values listed above.
- ④ For those whose external walls or glass areas are large, it is recommended to take the load calculation.
- ⑤ The heating load for the bathroom is generally 500W/room.

3.2 Selection of Tube Spacing of the Underfloor Coils

Tube spacing of the underfloor coils which will directly affect heat dissipation of the floor depends on the tube material, indoor design temperature, supply water temperature and floor material.

Heat Dissipation of Commonly Used Coils

(Tube material: PE-X, Indoor temperature:18°C, Average water temperature:45°C)

Floor Material	Thermal Resistance m ² -K/W	Tube Spacing mm	Heat Dissipation W/m ²	Tube Spacing mm	Heat Dissipation W/m ²
Stone	0.02	200	147.0	150	159.8
Wood	0.075	200	111.2	150	117.8

The dissipated heat of the floor coil is larger than the load for the floor heating system; however the deviation cannot be larger than 10%.

3.3 Selection of Loop Quantity of Coils for Each Room

3.3.1 Type of Underfloor Coils

When selecting underfloor coils, we should consider both their comfortability and heating capacity. The most commonly used coils are as shown below.

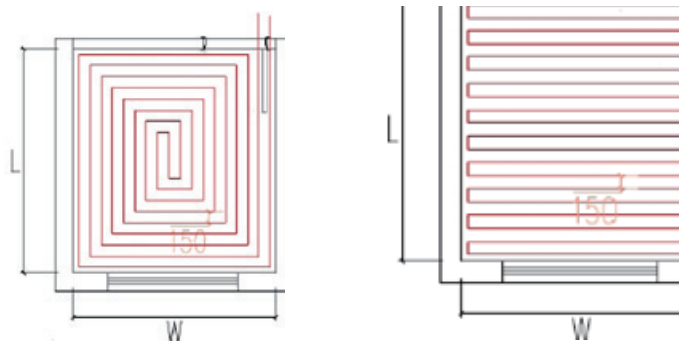

Square-shaped Coil (Recommended)

U-shaped Coil

Length of coils are calculated as below:

Square-shaped coil: $=L*W/tube\ spacing=area/tube\ spacing$

U-shaped coil: $=L-1+L*W/tube\ spacing=L-1+area/tube\ spacing$

The reason why the square-shaped coils are recommended is because they can keep even temperature

distribution. Special demand can be met by adjusting the tube spacing.

Distance from the room to the water trap/collector should be estimated according to the actual conditions of the project and generally should not exceed 30m.

3.3.2 Selection of Loop Quantity for Each Room

- ◆ Length of a single loop should not exceed 100m. If so, it should be divided into multiple loops.
- ◆ Area of a single loop=tube length×tube spacing=100m×150mm=15m²

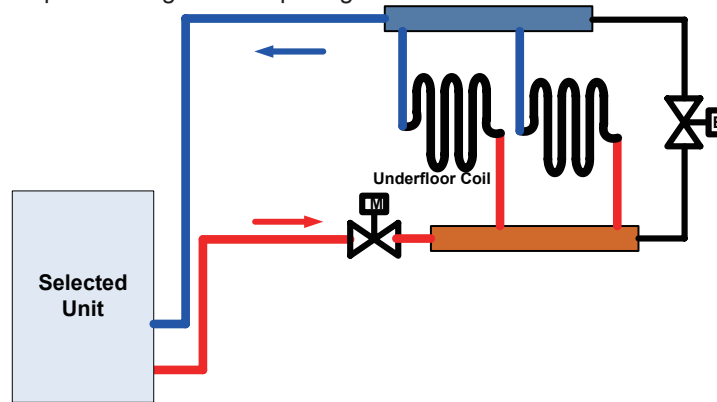

Length of underfloor coils is recommended to be within 100m and length of each branch should be kept the same to the most extent.

4 Quantity and Location of the Water Traps and Collectors

The water trap (collector) is a kind of device for distributing water for the water supply and return tubes.

4.1 Design Requirements on Loop Quantity for Circulation Water

- 1) One water trap (collector) is allowed for at most eight loops. When quantity of loops exceeds 12, then two traps (collectors) should be used, or it will cause uneven water distribution.
- 2) The maximum flow rate of the water trap (collector) should be less than 0.8m/s.
- 3) The inlet and outlet of each loop should be connected to the water trap (collector) and the inner diameter of the water trap (collector) should be or larger than that of the main water supply/return tube.

Calculation of loop quantity for circulation water can be done as per the formula below

$$N=A/A1$$

N——loop quantity

A—— total floor heating area (unit: m²)

A1—— floor heating area per single loop (unit: m²)

Example for how to calculating the floor heating area per single loop: when the tube length is 120m, and tube spacing is 200mm, then the floor heating area per single loop is 120×0.2=24m².

- 4) One trap (collector) cannot be used for different floors, or it would cause uneven water distribution.

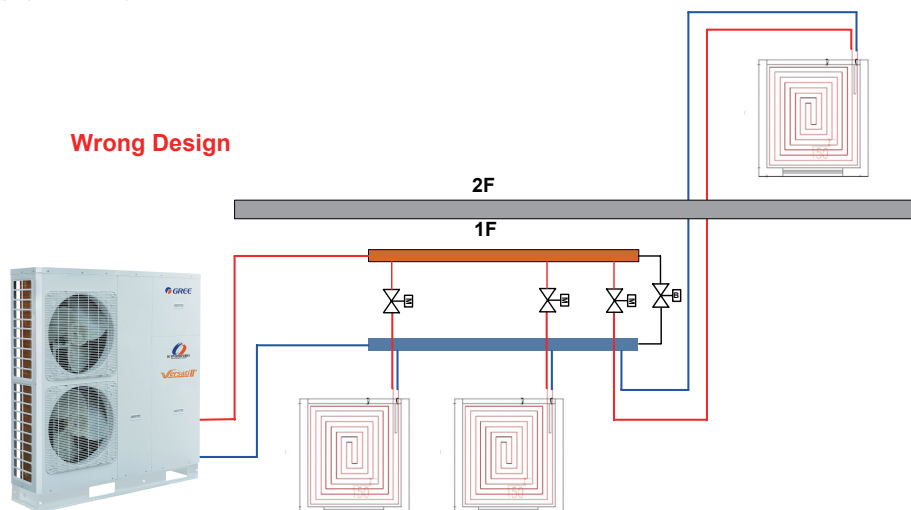

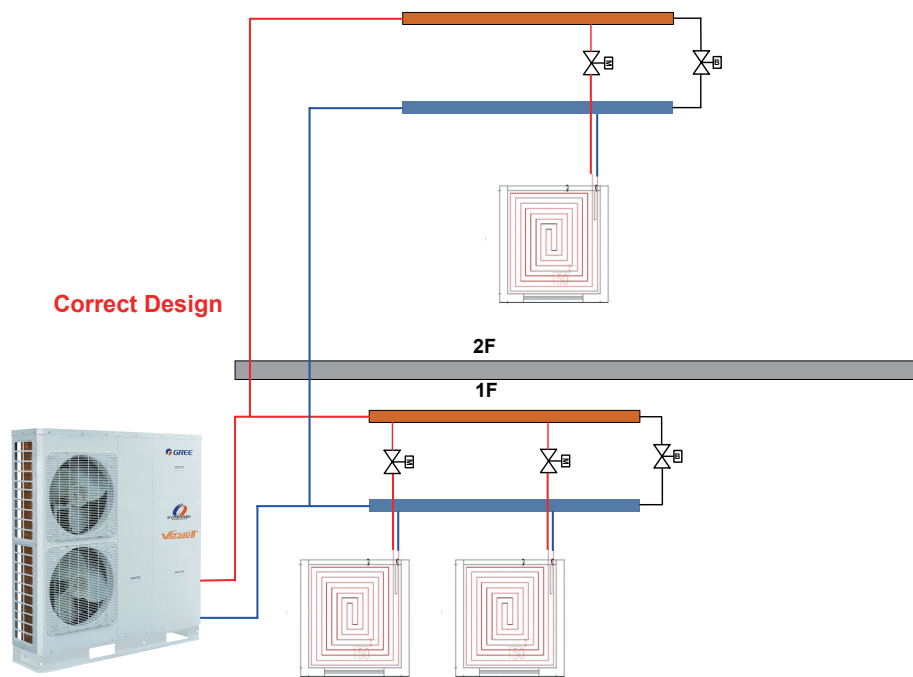

5) Distance between the unit and the water trap (collector) should be within 15m. If the distance exceeds 20m, then it is required to calculate the hydraulic power.

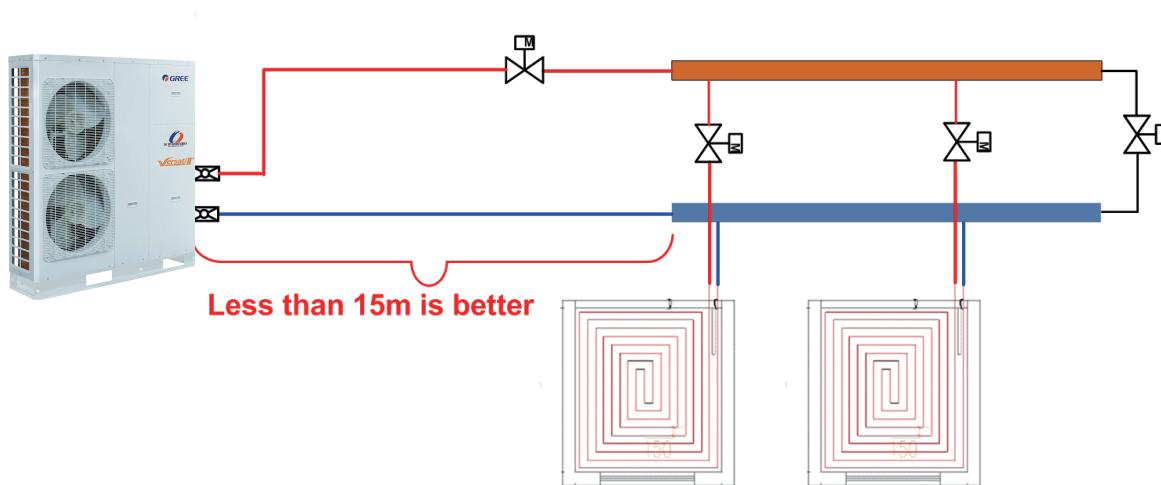

4.2 Requirements on Installation of the Water Trap (Collector)

1) The water trap (collector) should be installed on the wall or inside the special box. For housing constructions, it is generally installed in the kitchen.

2) The valve for the water trap (collector) should be installed horizontally and keep a distance of at least 300mm to the ground.

3) The water supply valve should be installed upstream of the water trap (collector) and the return valve should be installed downstream of the water trap (collector)

4) A filter is required upstream of the water trap (collector).

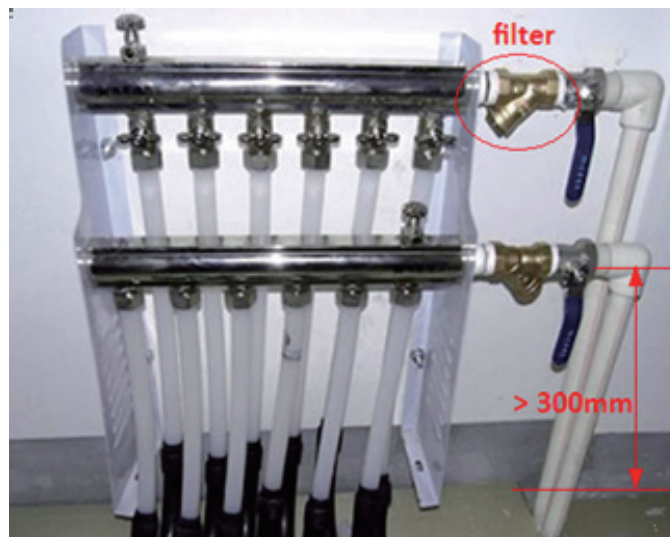

5 Section of FCU

5.1 FCU Type Selection





The air-water fan coil unit is optional for Versati units

5.2 Matching of Capacity

Load of the FCU is better to be between 70%~120% of the Versati unit.

Notes:

- ① When load of the FCU is too small, the unit would start/stop frequently, which is adverse for oil return.
- ② When load of the FCU is too large, the unit would always run under high frequency, which is unhelpful for energy conservation.

Type	Air Volume (m ³ /h)	Cooling Capacity (kW)	Heating Capacity (kW)	Static Pressure (Pa)	Appearance
Wall mounted type	166~1020	2.1~5.4	3.15~8.5	—	
Concealed ceiling type	213~2380	1.85~12.8	3.1~21	12, 30	
Floor ceiling type	213~2040	1.9~10.8	2.8~16.2	—	
Cassette type	480~1700	4.5~9	6.8~13.7	—	

6 Selection of the Water Tank

6.1 Specifications of the Water Tank

SXVD200LCJ/A-K	220~240V-1Ph-50Hz
SXVD300LCJ/A-K	A single coil with the electric heater is integrated, used for floor heating system
SXVD200LCJ2/A-K	220~240V-1Ph-50Hz
SXVD300LCJ2/A-K	Dual coils with the electric heater are integrated, used for floor heating system and the solar system
SXVD200LCJ/A-M	380~415V-3Ph-50Hz
SXVD300LCJ/A-M	A single coil with the electric heater is integrated, used for floor heating system
SXVD200LCJ2/A-M	380~415V-3Ph-50Hz
	Dual coils with the electric heater are integrated, used for floor heating system and the solar system

6.2 Volume Selection of the Water Tank

6.2.1 Selection Based on Water Consumption Per Capita

Building Type	Unit	Daily Water Consumption (L)	Water Temperature (°C)
House	Per person, Per day	40~80	60
Villa	Per person, Per day	70~110	60

6.2.2 Selection Based on Sanitary Utensils

Utensil Type	Daily Water Consumption (L)	Water Temperature (°C)
Bathtub, Sprinkler system (with shower)	150	40
Bathtub, Sprinkler system (without shower)	125	40
Shower	70~100	37~40
Wash Basin	3	30

6.2.3 Selection of the Water Tank

Selection of the water tank should consider the flow rate of the shower head, duration of use per person and daily water consumption.

$$\text{Volume of the Water Tank} = \frac{t(\text{design temperature}) - t(\text{entering cold water temperature})}{t(\text{water tank temperature set point}) - t(\text{entering cold water temperature})} \cdot \text{consumption}$$

$$= \alpha \cdot \text{consumption}$$

t (design temperature): generally it is 60°C ;

t (entering cold water temperature): it differs for different regions.

t (water tank temperature set point): it is the target heating temperature of the water tank

α: correction factor

Empirical Values for Volume Correction of the Water Tank

Duration of Use (min/Person) Flow Rate of the Shower Head (L/min)	Duration of Use (min/Person)					
	10	15	20	25	30	40
4	0.48	0.71	0.94	1.18	1.42	1.89
6	0.71	1.06	1.42	1.77	2.12	2.83
8	0.95	1.42	1.89	2.36	2.83	3.77
10	1.18	1.77	2.36	2.95	3.54	4.72
15	1.76	2.65	3.54	4.42	5.31	7.08

Empirical values are worked out under conditions of 80L consumption (per day per person), 8L/min flow rate of the shower head, and 10 minutes use duration per person.

7 Examples for Model Selection

7.1 General Introduction to the Example Project

For a two-floor house, there is a master room and a both room for each floor and both of them require floor heating. Other rooms use the heat pump for heating in winter. The master room covers 28m² and the both room covers 12m².

7.2 Heat Load Calculation

7.2.1 Load Calculation of a Single Floor

Room	Area	Heat Index (W/m ²)	Heat Load (W)
Master Room	28	82	2296
Bathroom	12	72	900
Total Load			2296+900=3196w

7.2.2 Arrangement Design of the Underfloor System for A Single Floor

Assumed conditions: the floor is cement or ceramics, the normal external diameter of the heating pipe is 20mm, thickness of the stuffer is 50mm, thickness of PS foam insulation is 20mm, supply water temperature is 45°C, return water temperature is 35°C, indoor design temperature is 20°C.

$$\text{Average Temperature of the Heating Pipe}=(45+35)/2=40^{\circ}\text{C}$$

7.2.3 Arrangement Design of the Underfloor System for the Bath Room

Heat load of the bath room is 900W, heat dissipation per unit area is 75W/m², tube spacing of the heat pipe is 30mm, and heat loss is 25.4 W/m², then the total heat loss is:

$$25.4 \times 12 = 304.8\text{W}$$

Based on the heat load listed in the table above, the heating load for the bathroom is:

$$900 + 304.8 = 1204.8\text{W}$$

According to the formula $Q=C_pG\Delta T$, the flow rate of the heating pipe for the bathroom is:

$$G = \frac{Q}{C_p\Delta T} = \frac{1.2048\text{kJ}/(1/3600\text{h})}{4.186\text{kJ}/(\text{kg}\cdot^{\circ}\text{C}) \times 1000\text{kg}/\text{m}^3 \times (45-35)^{\circ}\text{C}} = 0.104\text{m}^3/\text{h}$$

If the outer diameter of the heating pipe is 20mm and thickness is 2mm, then the minimum flow for the heating pipe is:

$$G = \pi/4 D^2v = 3.14/4 \times (20-2 \times 2)^2 \times 10^{-6} \times 0.25 \times 3600 = (0.18\text{m}^3)/\text{h}$$

It can be seen that the arranged piping system for the bathroom does not meet the technical requirement and must be used in common for the master room.

7.2.4 Arrangement Design of the Underfloor System for the Master and Both Rooms

According to the calculation results, the total heat load for the master and bath rooms is 3196W, heat dissipation per unit area is 82W/m², tube spacing of the heating pipe is 300mm, and heat loss 25.4 W/m² is, then the total heat loss is:

$$3196 + 1016 = 4212\text{W}$$

According to the formula $Q= C_pG\Delta T$, the flow rate is

$$G = \frac{Q}{C_p\Delta T} = \frac{4.212\text{kJ}/(1/3600\text{h})}{4.186\text{kJ}/(\text{kg}\cdot^{\circ}\text{C}) \times 1000\text{kg}/\text{m}^3 \times (45-35)^{\circ}\text{C}} = 0.3622\text{m}^3/\text{h} > 0.18\text{m}^3/\text{h}$$

Loop quantity is $0.3622/0.18=2.012$ and the round-off number is 2.

7.2.5 Check

- ◆ A. Check for the flow rate

$$\frac{0.3622/2}{3.14 \times 0.008^2 \times 3600} = 0.2503\text{m/s}$$

Floor rate of each loop is within 0.25~0.5m/s and the system can run stably.

- ◆ B. Check for the tube length

When the average tube spacing is 30mm, the required length of the heating pipe per square meter is 3.5m, length of total coils is $3.5 \times 40 = 140$ and length for each loop is $140/2 = 70$.

It can be seen that the length for each loop is less than 120m and there it meets the design requirement.

- ◆ C. Check for the ground average temperature

$$t_p = t_n + 9.82 \times (q_x/100) \quad 0.969 = 20 + 9.82 \times (82/100) \quad 0.969 = 28^{\circ}\text{C}$$

Upper Limits and Average Floor Temperature

Average Floor Temperature		
Area	Average Temperature	Maximum Temperature
Long-term Dwelling Area	24~26	28
Short-term Dwelling Area	28~30	32
Nobody Area	35~40	42

7.3 Model Selection

Heat demand for a single layer: 3196W

Heat loss for a single layer: 1016W

Total heat load for a single layer: 4212W

Total heat load of the building: 8424W

Capacity of the main unit should be larger than 8424W, so we can select: **GRS-CQ10Pd/NaC-K**

GREE ELECTRIC APPLIANCES, INC. OF ZHUHAI

Add: West Jinji Rd, Qianshan, Zhuhai, Guangdong, China, 519070

Tel: (+86-756) 8522218 Fax: (+86-756) 8669426

E-mail: gree@gree.com.cn www.gree.com



For continuous improvement in the products, Gree reserves the right to modify the product specification and appearance in this manual without notice and without incurring any obligations.
