

GKD TECHNOLOGIES

2RCI User Manual

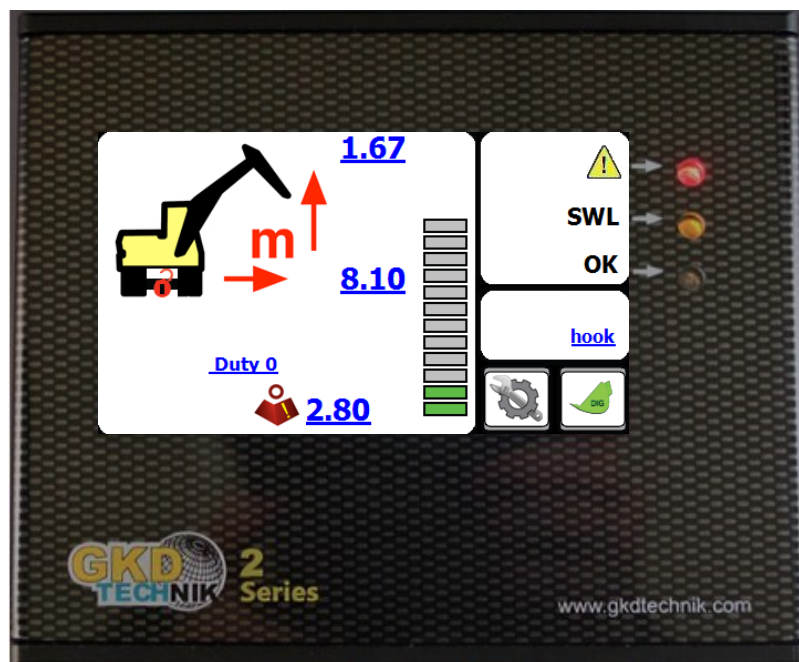

Change History

Issue	Date	Changes	Job
V1.0	01/09/2014	Document created. Update from the NPN V5 version	
V1.1	26/11/2014	Add Slew and I/O module options	
V1.2	04/07/2016	General update and reformat of entire document	
V1.3	16/08/2017	Added new Virtual wall functionality	
V1.4	20/11/2017	Update to new branding and part numbers	

Contents

	Page no
Change History	2
Introduction	4
<i>Operation</i>	4
<i>Front Screen</i>	4
Lifting Operation	5
<i>Lifting Duties</i>	5
<i>Selection of Lift Attachment - Options</i>	5
<i>Manual Lifting Duty Selection (Jib and Forks Versions)</i>	5
Lifting Mode	6
<i>Hook/Bucket Duty</i>	6
<i>Forks Duty</i>	6
<i>Jib Duty</i>	6
Mode Menu	7
<i>Setting a Height Limit</i>	7
<i>Cancelling a Height Limit</i>	8
<i>Setting a Slew Limit</i>	8
<i>Virtual Walls</i>	9
Dig Mode	12
<i>Depth Setting</i>	13
Automatic Slew Based Lifting Duties	14
Full Motion Cut on Overload	15
Test Function	15
System Layout	16
<i>Component Location</i>	16

Introduction

This is the operation manual for the 2RCI range of rated capacity indicators.
This product is a safety product.

**WARNING - DURING NORMAL OPERATION THE RATED CAPACITY OF A CRANE SHOULD NOT BE EXCEEDED. THEREFORE THE OVERLOAD WARNING SHOULD NOT BE USED AS A NORMAL MODE OF OPERATION. STATUTORY REQUIREMENTS DO NOT PERMIT THE RATED CAPACITY TO BE EXCEEDED EXCEPT FOR THE PURPOSE OF TESTING.
THIS RCI IS NOT FOR USE IN EXPLOSIVE ATMOSPHERES.
ADJUSTMENT BY NON AUTHORIZED PERSONNEL WILL INVALIDATE THE WARRANTY.**

Operation

The 2RCI system is wired to automatically start whenever the machine is started. There is no operator ON/OFF control. At switch on the system will initially show a blank screen and the green LED on the front panel will blink. Once self tests are complete the indicator screen will illuminate. The system will automatically start in the lift mode.

Front Screen

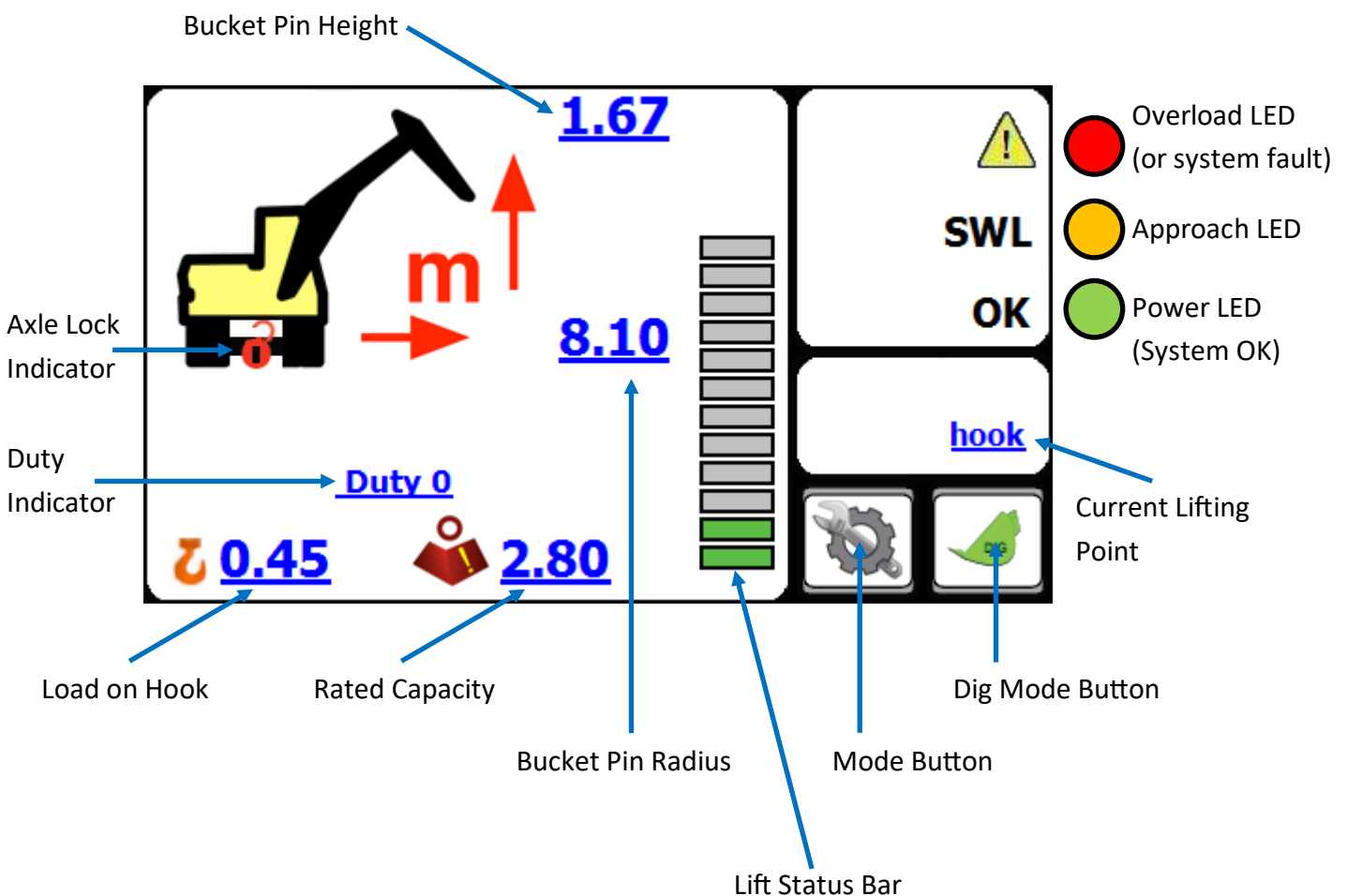

Lifting Operation

In lifting mode the 2RCI system displays the current radius and height of the lifting point and the related maximum rated capacity. The status graph shows the current load relative to the maximum. The red and amber LEDs on the front panel provide an indication of approach to and exceeding of rated capacity. An external and internal (where fitted) sounder will also indicate the current status.

Lifting Duties

The 2RCI system may be calibrated to provide lifting capacity ratings for different configurations of machine. The switching between duties may be automatic via external limit switches or automatically selected from machine slew position (slew module option only), or manual via the 'MODE' screen. The lifting duty number is shown on the front screen.

Selection of Lift Attachment - Options

2RCI supports the use of Forks or Demountable Jibs for lifting and height limiting purposes. In the standard configuration, only the Bucket Pin is defined as the lift attachment, and no other selection is available unless they have been enabled and set up within the system calibration menus.

Manual Lifting Duty Selection (Jib and Forks Versions)

Selection of the lifting mode is made from the MODE screen. Access to this screen is by pressing the MODE button on the front screen. There are three available lift configurations. The mode is selected by repeatedly pressing the coloured lift duty button.

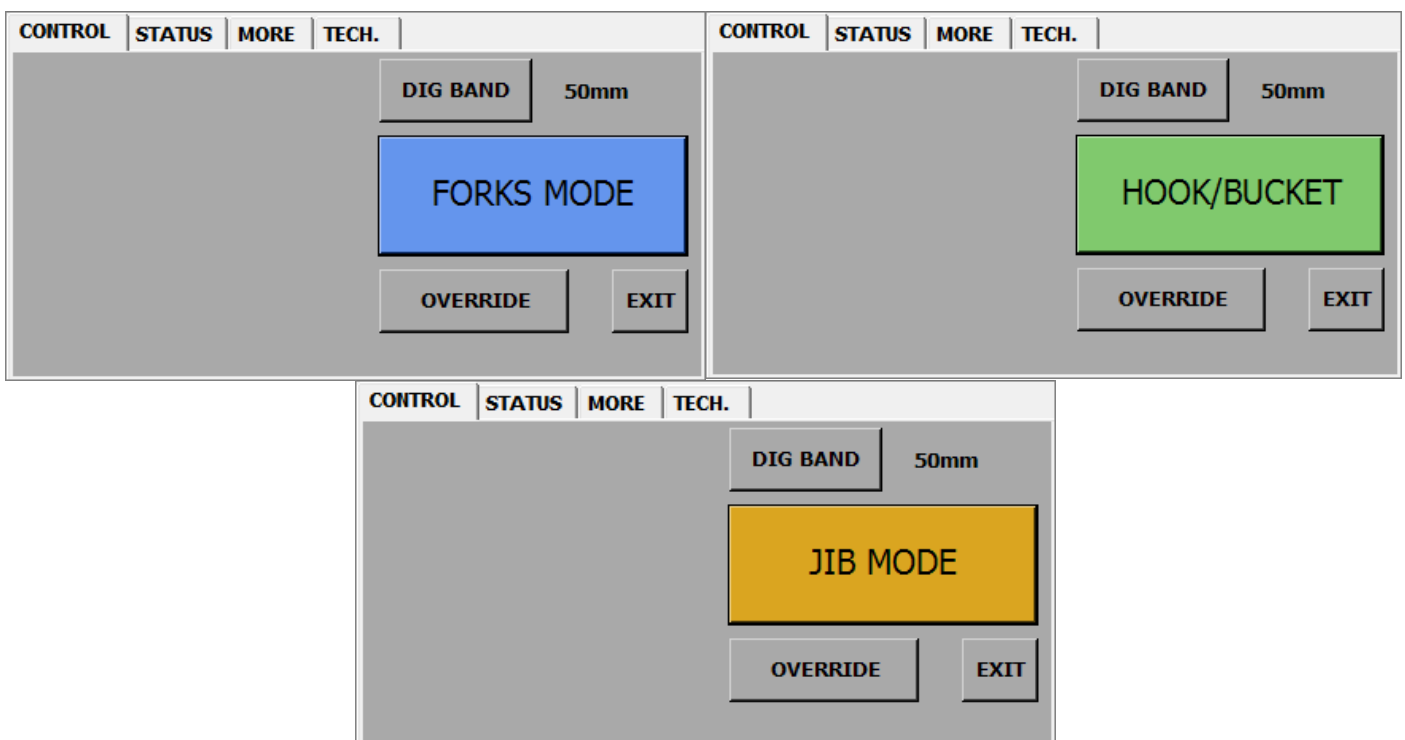

Lifting Mode

Hook/Bucket duty

This is the standard excavator lifting configuration. The radius and height are measured to the bucket pin on the stick and all calculations of rated capacity are referenced to this position. The front screen of the indicator will show a duty status 'hook'.

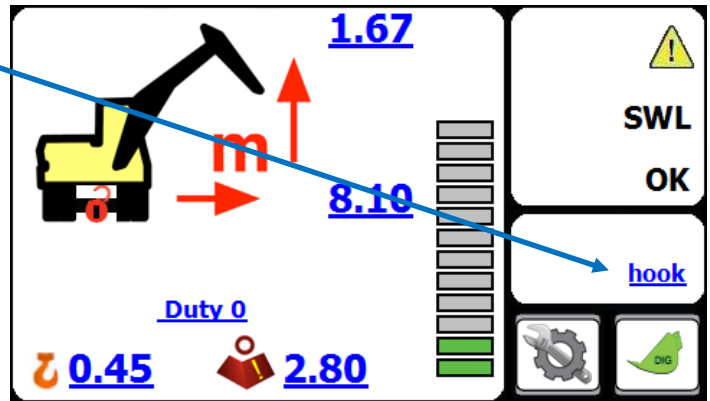

Forks Duty

When the forks are attached to the machine the system will provide a height and radius offset to the position of the load on the forks. As well as showing a duty status of 'forks'. In addition there is an automatic height limit applied to the fork mode. This height limit is pre-set at 2.5m (the screenshot to the right shows the status and height limit).

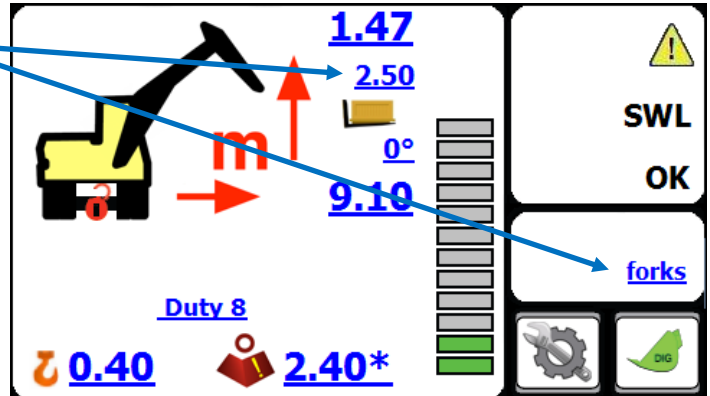

Jib duty

When the extension jib is fitted to the machine this duty adjusts the lifting capacity to be measured at the end of the jib. The front screen will show a 'JIB' status. In addition there is a warning if the hydraulic pressure is exceeded in the jib cylinder.

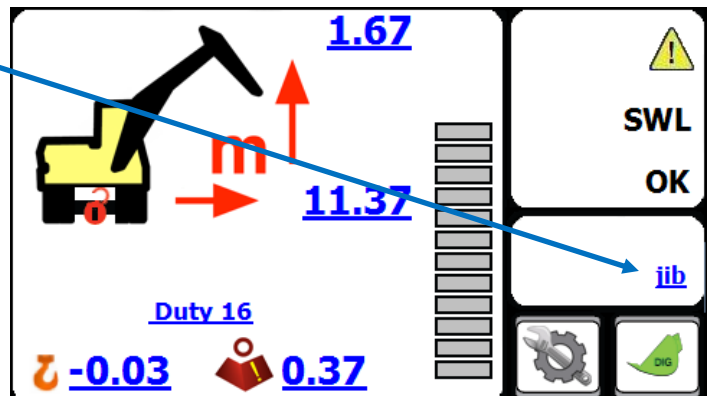

Mode Menu

From the main screen, press on the Mode button.



The following window should appear:

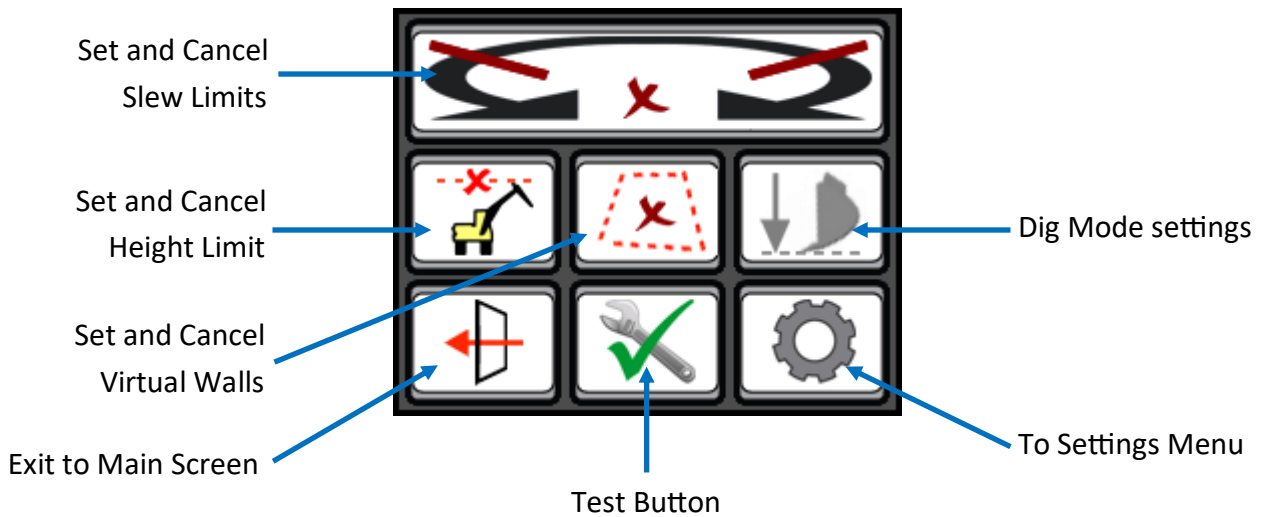

Setting a Height Limit

From the Mode Menu, press on the “Height Limit” button.



The system will ask if you want to enter the maximum height limit with the keyboard. Pressing “YES” will bring up a keyboard screen. Enter the height in metres and press OK. [Pressing exit without entering data will switch off the limit].

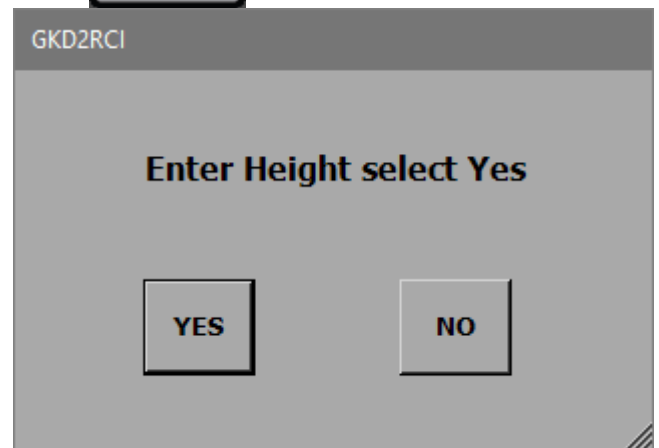

Pressing “NO” will allow the height to be set by moving the machine to the maximum height.

Press “YES” when the machine is in the correct position. NOTE this screen will timeout if not selected within 10 seconds.

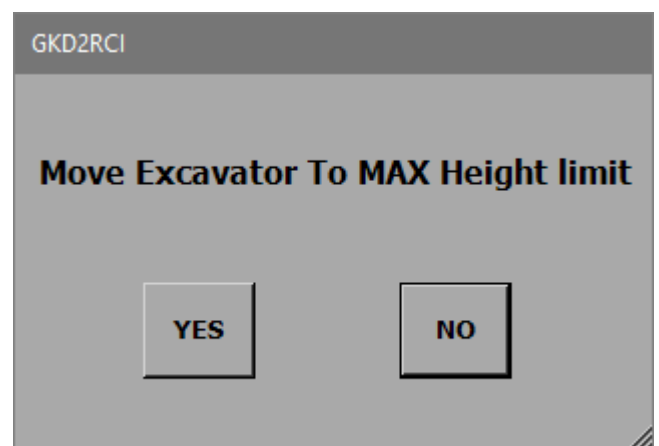

Height Limit continued...

When there is a height limit set, this will be shown on the main screen.

If the height is exceeded then the internal buzzer will sound and the boom lift will be cut (if an optional motion valve is fitted).

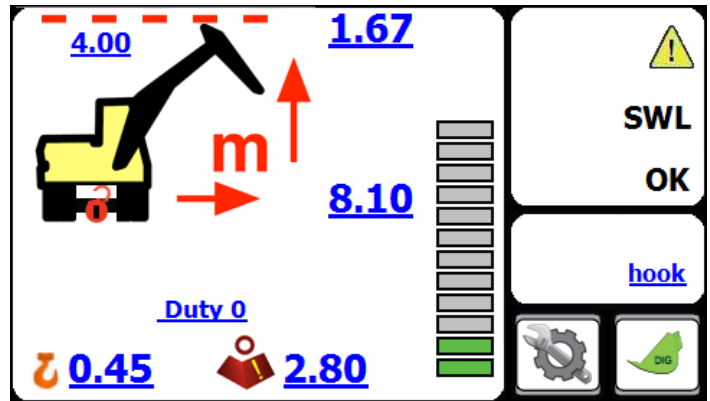

Cancelling a Height Limit

Access the Mode Menu and press on the “Height Limit” button.

The 2RCI will prompt the operator to confirm that the height limit should be disabled, as shown here. Pressing “YES” will disable the height limit function.

Normal operation will be resumed but with no height limit active.

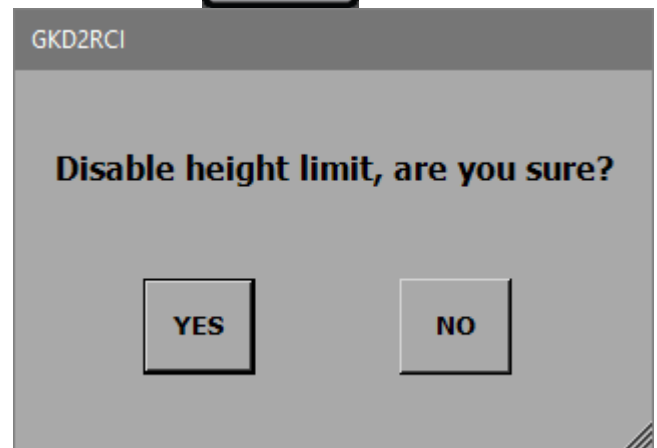

Setting a Slew Limit

From the Mode Menu, press on the “Set/Cancel Slew Limit” button.

The 2RCI will then show you this screen:

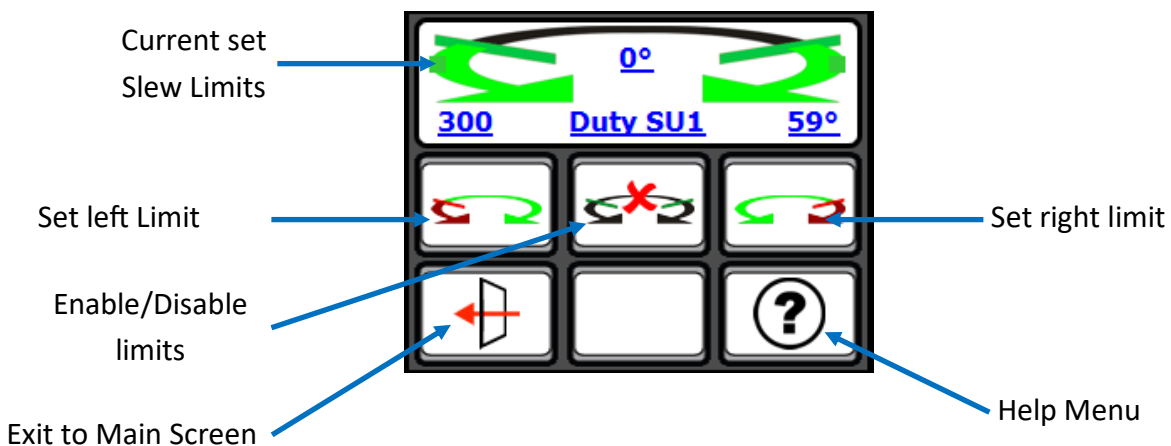

To set slew limits, slew the machine left to required position and press the “Set Left Limit” button. Then slew the machine right to the required position and press the “Set Right Limit” button. Return to the operator screen and check that the limits are working correctly by slewing the machine left and right until the limits are reached.

Virtual Walls

From the main screen, press on the Mode button:



Then press on the Virtual Wall button:



You should be shown the screen below:

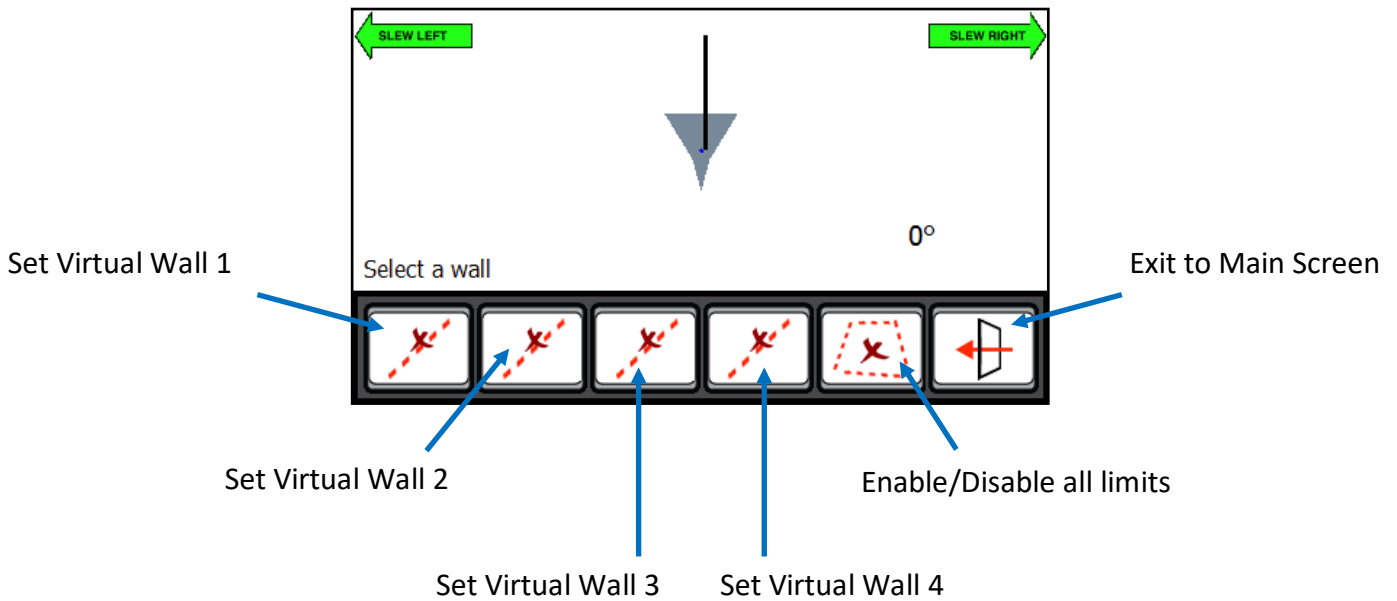

Pressing on any of the “**Set Virtual Wall**” buttons will display the following screen:

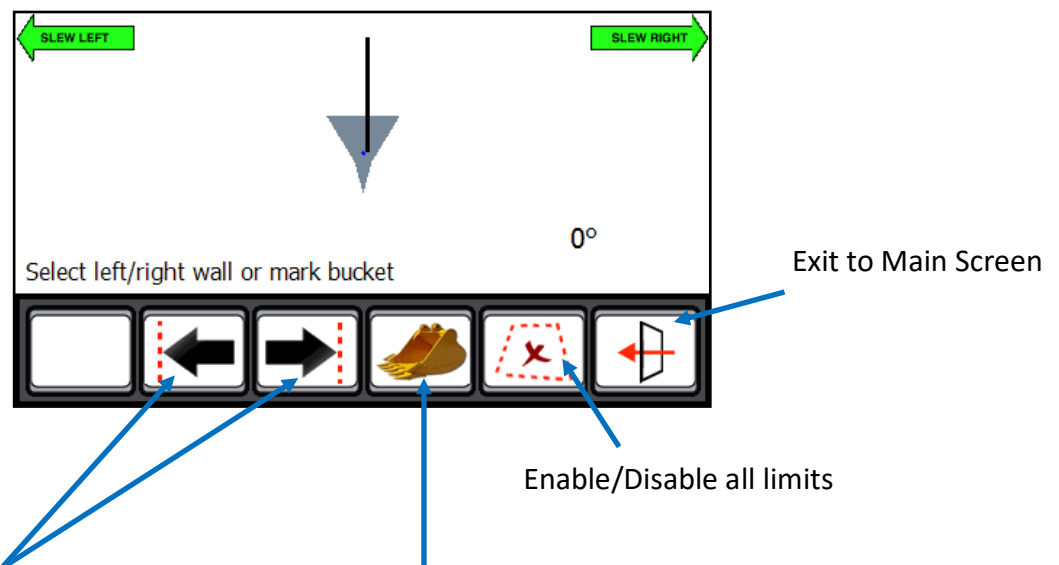

Set a left or right virtual wall which will be parallel with the tracks or wheels of the machine.

This is entered as a distance, in metres, from the centre of the machine.

Set a virtual wall by moving the bucket or tool to 2 different points near the machine. The system will then connect these points with a ‘virtual wall’ which will then become the limit.

Virtual Walls continued...

Setting a virtual wall by entering a distance

Press on the “**Set Virtual Wall 1**” button.
Then press on the “**Left Wall**” button.
A keypad will open for you to enter the distance to the left wall, in metres.
Enter the distance and press ok.

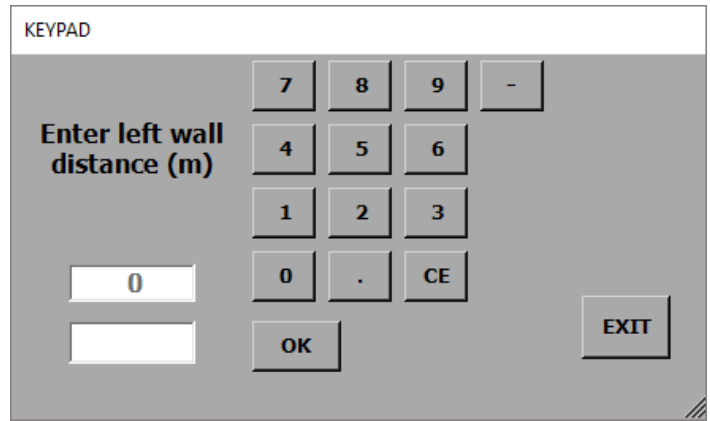

The screen should now change back to one similar to that pictured to the right.

The “**Set Virtual Wall 1**” button will now be greyed out. Pressing on this button will activate the virtual wall and the button will change to indicate that the virtual wall is not active.

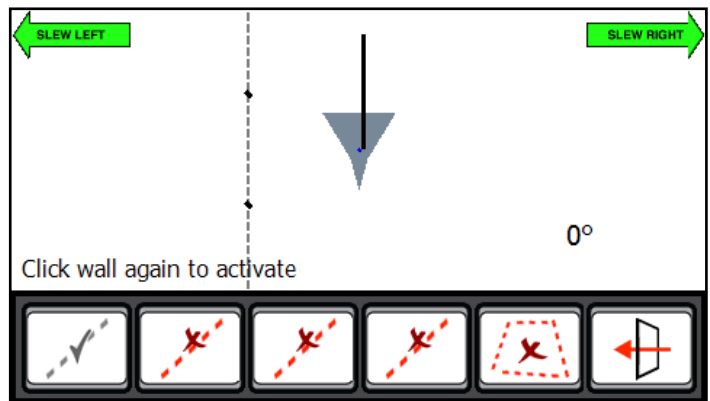

The screen pictured to the right, shows a virtual wall set and active.

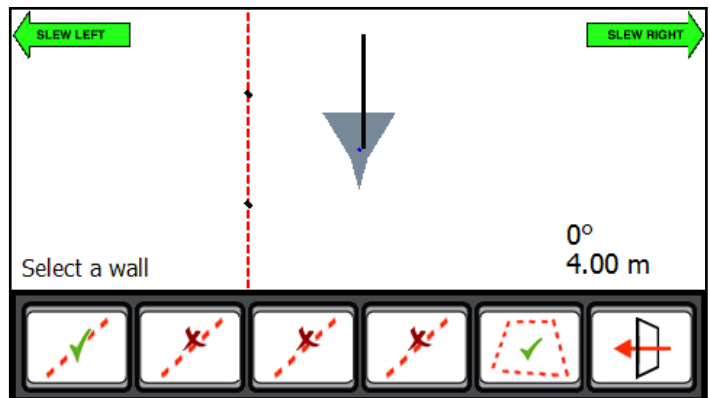

The screen pictured to the right, shows the main operator screen once the virtual wall has been set and activated.

The top right corner of the display will show where the virtual wall is in relation to the machine. It will also show the distance to the virtual wall from the machine.

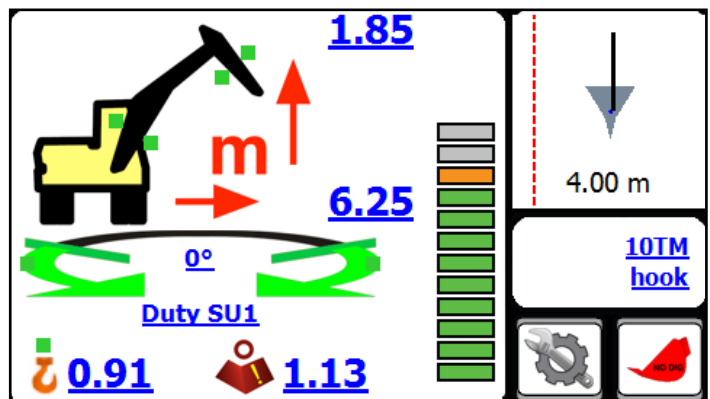

As the machine slews, its position and distance to the wall will be updated automatically.
When the machine reaches the virtual wall, all relevant machine motions will be prevented from breaching the wall. This includes Boom and Dipper motions.

Virtual Walls continued...

Setting a virtual wall using the bucket

Move the machine and position the bucket where the first point of the wall is required.

Press on the **“Bucket”** button.

The system will log this point as the first point of the virtual wall.

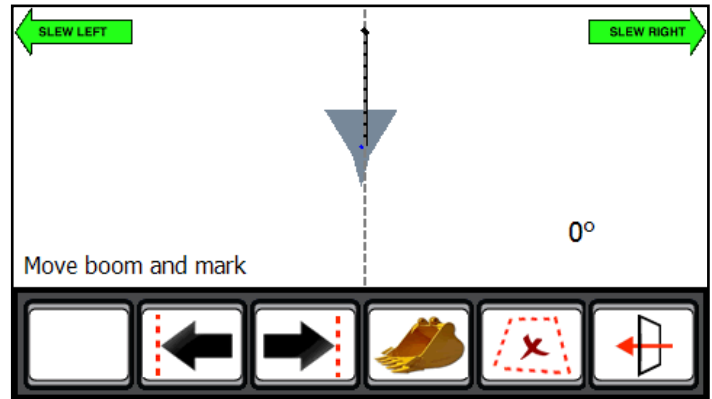

Slew the machine to move the bucket to the second position. As the machine moves, you will see the screen update and create a virtual wall between the first point and where the bucket is.

Once you have positioned the machine at the second point, press the **“Bucket”** button again. This will log the second point of the virtual wall.

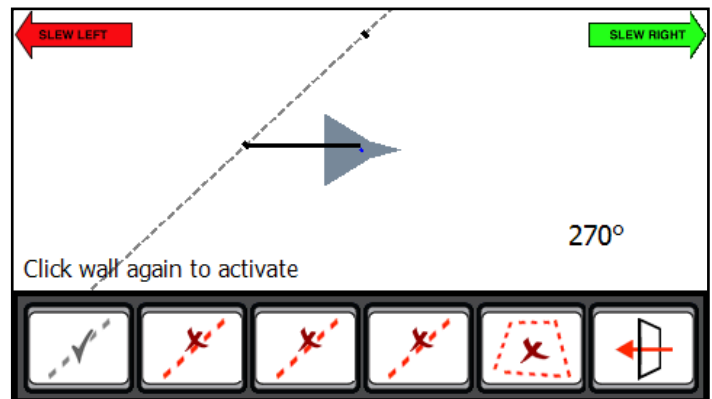

The **“Set Virtual Wall 1”** button will now be greyed out. Pressing on this button will activate the virtual wall and the button will change to indicate that the virtual wall is not active.

This method is the same for Virtual Walls 2,3 & 4.

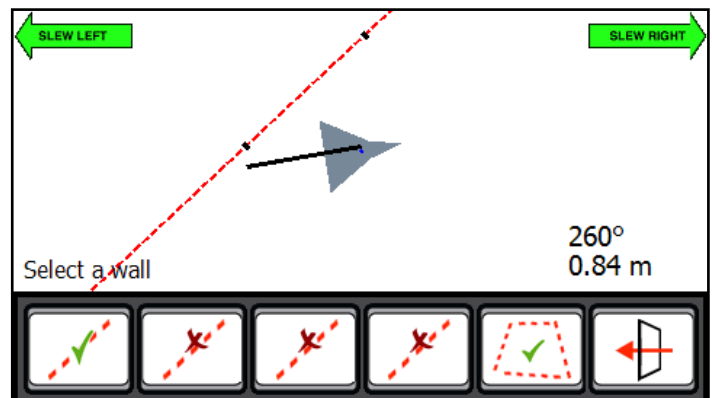

The screen pictured to the right, shows the main operator screen once the virtual wall has been set and activated.

The top right corner of the display will show where the virtual wall is in relation to the machine. It will also show the distance to the virtual wall from the machine.

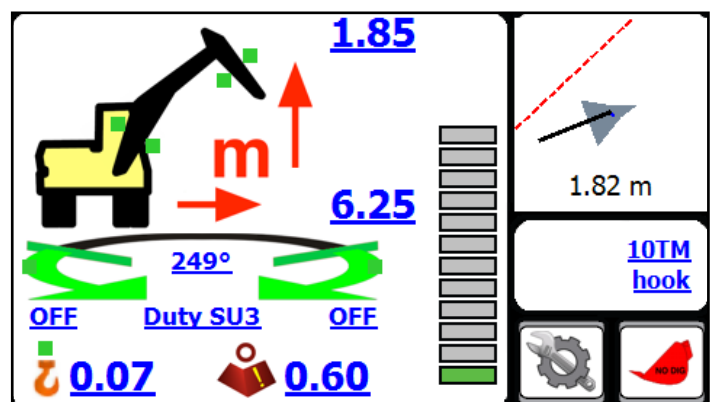

As the machine slews, its position and distance to the wall will be updated automatically.

When the machine reaches the virtual wall, all relevant machine motions will be prevented from breaching the wall. This includes Boom and Dipper motions.

Dig Mode

When the excavator is not being used for lifting operations then the 2RCI should be switched into dig mode. In dig mode the alarm is muted and any motion cuts (if fitted) will not be activated in the event of an overload situation. While in dig mode, the 2RCI provides a guide to levelling or trenching.

To enter Dig Mode, press on the dig button.



The 2RCI will prompt the operator to confirm that they want to switch into Dig Mode.

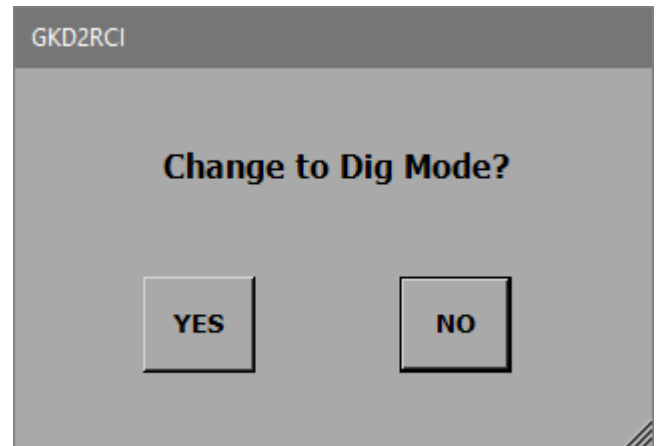

Pressing "YES" will switch the 2RCI into dig mode and the main screen should now look like this:

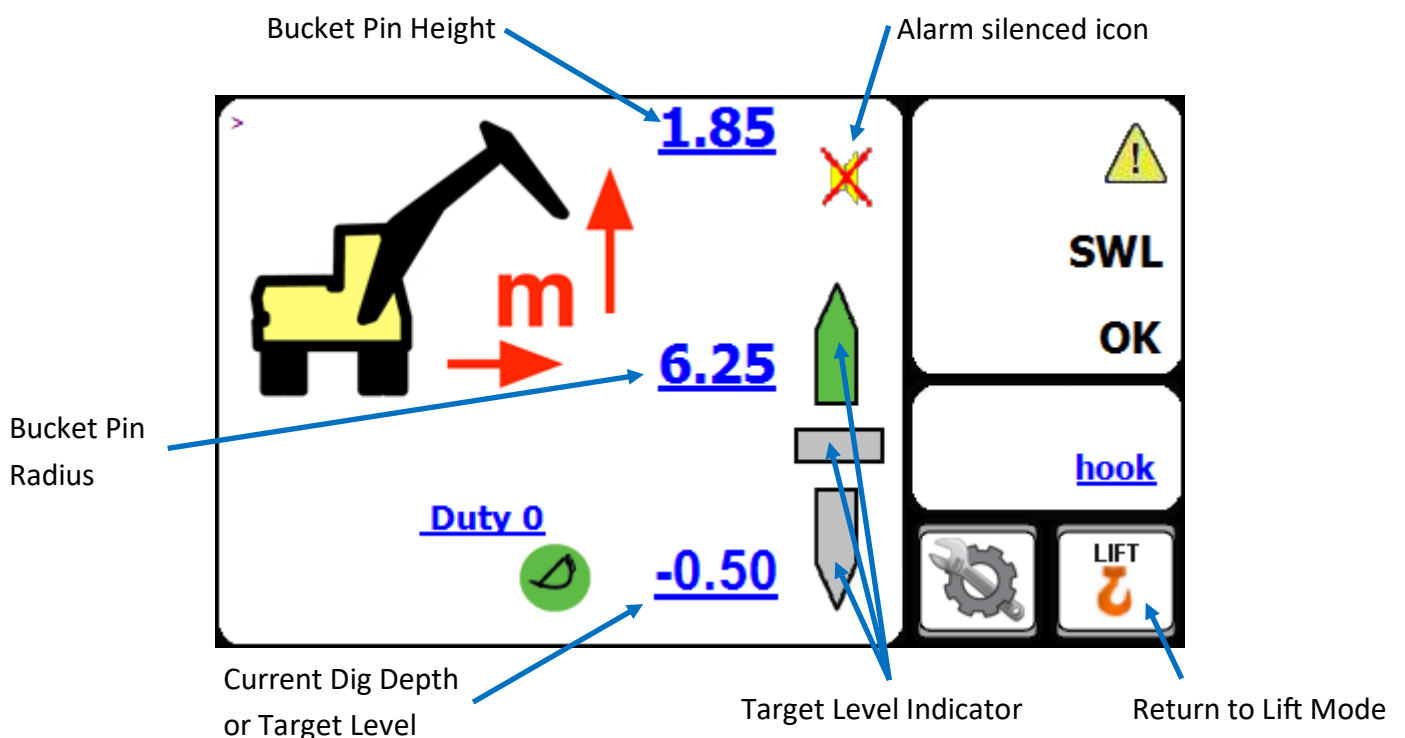

To exit Dig Mode and return to Lifting Mode, press on the "Return to Lift Mode" button, shown above.

Dig Mode continued...

Depth Setting



To adjust or set the dig depth, press on the  button which is in the Mode Menu.

The system will ask you if you want to enter a depth using the on screen keypad. Press **“YES”** to access the keypad. Enter a depth that is relative to the base point of the boom and press enter. Press exit from the keypad to deselect the dig mode.

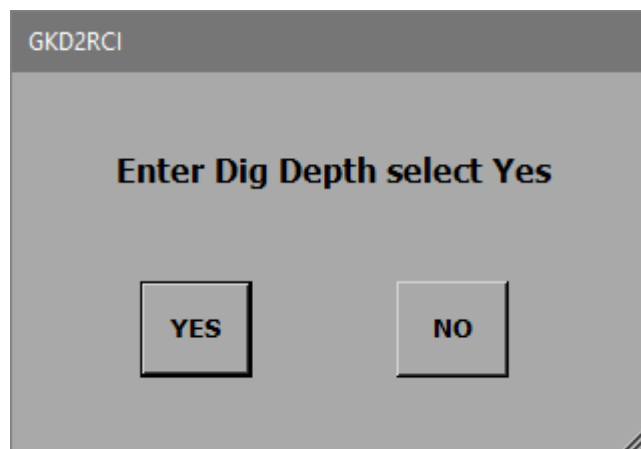

Pressing **“NO”** will allow the operator to use the position entry mode.

Place the bucket at the level required and press **“YES”**. The system will now use this position as the target depth.

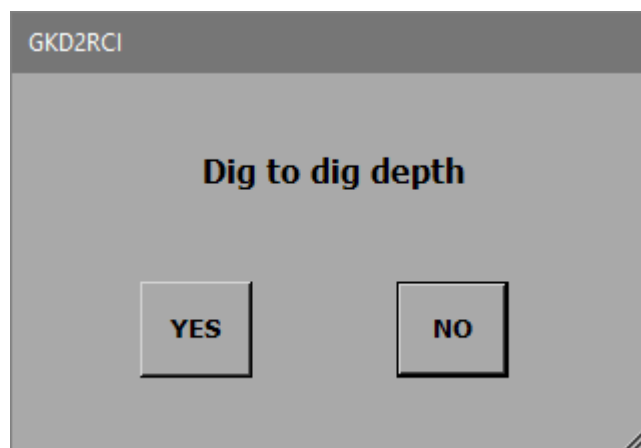

When in digging mode the system provides a level indicator. The indicator shows the target level. There are three states for the indicator, as shown below:

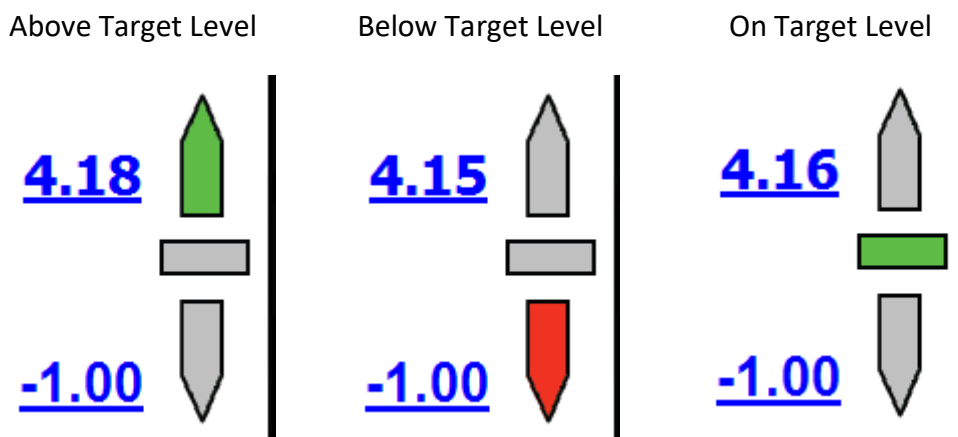

NOTE - The depth indication is measured to the load point. The orientation of the bucket will affect the accuracy of the indicator. Moving the machine from one level to another will change the depth of a trench. Whenever the machine is moved it is recommended that the depth is reset by placing the bucket on the level previously dug and reset the depth by pressing dig mode, **“NO”** and **“YES”** to make the new bucket position to datum.

Automatic Slew Based Lifting Duties

The 2RCI system may optionally be equipped with an additional module to monitor the slew position of the turret relative to the machine undercarriage, and automatically select lift duties based on the slew position of the turret.

Current duty in use, and the current slew position of the turret relative to the undercarriage, are indicated on the 2RCI display.

Current slew position of the turret in degrees (0°-360°)

Current Slew Duty (SU1 - SU5)

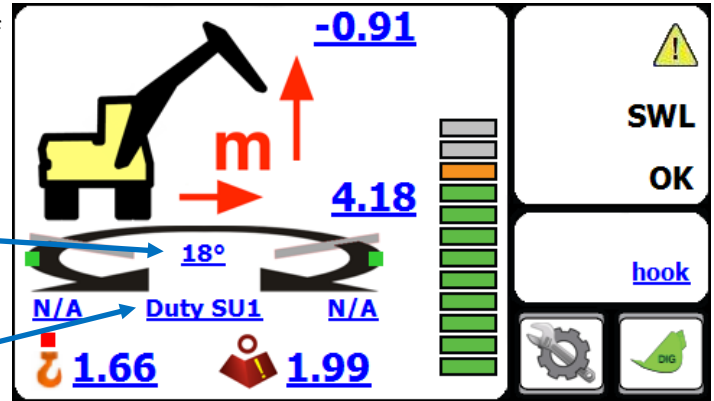

Typically, eight slew “duties” are available. The duties are named SU1 - SU5, with each duty having its own calibrated “tip” point for the machine.

As the turret is slewed the appropriate lift duty for the slew position is automatically selected, and the lift capacity calculated by the RCI will be adjusted for the slew position of the machine based on the duty in use.

Thus, more lift capacity can be attained for the machine over the front and rear than over the side, and the machine’s lift capability is maximised for the slew position of the machine.

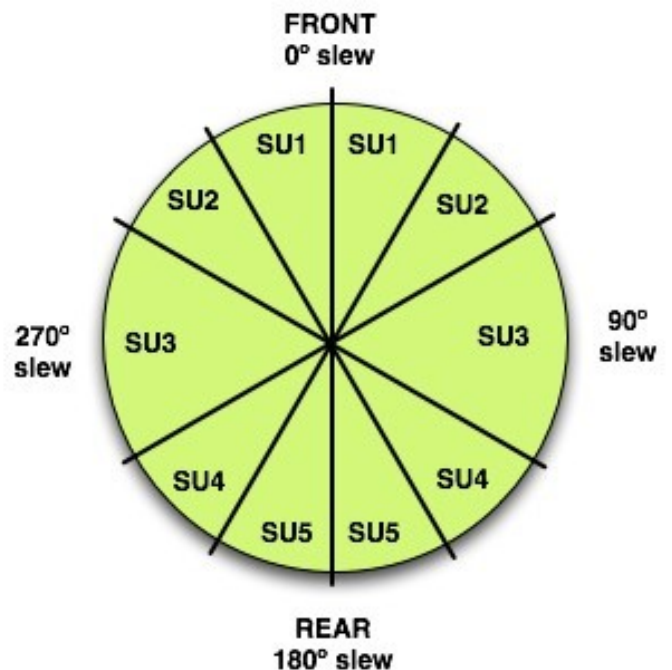

Full Motion Cut on Overload

The 2RCI can be optionally equipped with an additional I/O module, which enables the 2RCI to control additional motion cut valves. This makes it possible to offer full intelligent motion cut of boom functions on overload to prevent the machine from being moved further into an unsafe overload state. All boom functions that will reduce the lift radius and move the load to a safer position remain enabled.

An indication of boom motion cut status is shown by a series of coloured dots on the machine graphic. On motion cut, the dot that symbolises any hydraulic function that would take the system further into overload.

In normal operation, these dots will be green. This indicates that motion are allowed.

When in overload, these dots will turn red. This indicates that motion is prevented (the motion is cut).

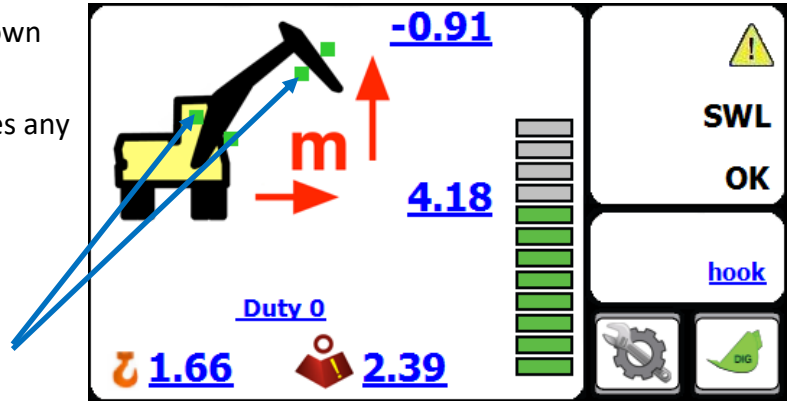

Test Function

Pressing the “TEST” button will activate the internal and external alarms and operate any motion cut valves that may be connected for a period of around five seconds. The test button sequence should be carried out regularly to verify the correct operation of warning devices.

To access the “TEST” button, first press the “MENU” button.



Then you can press on the “TEST” button.



System Layout

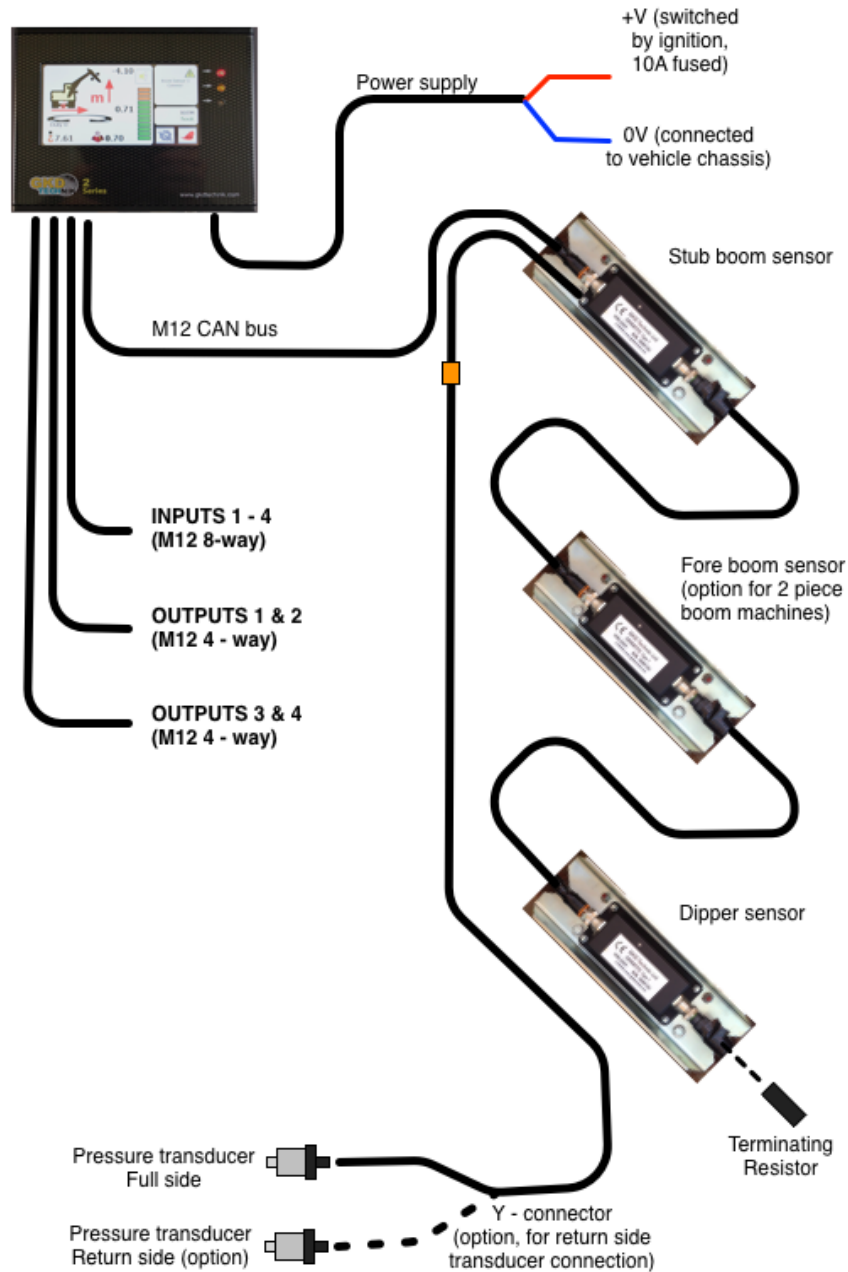

Component Location

Typical locations of 2RCI components as installed onto a machine are shown here.

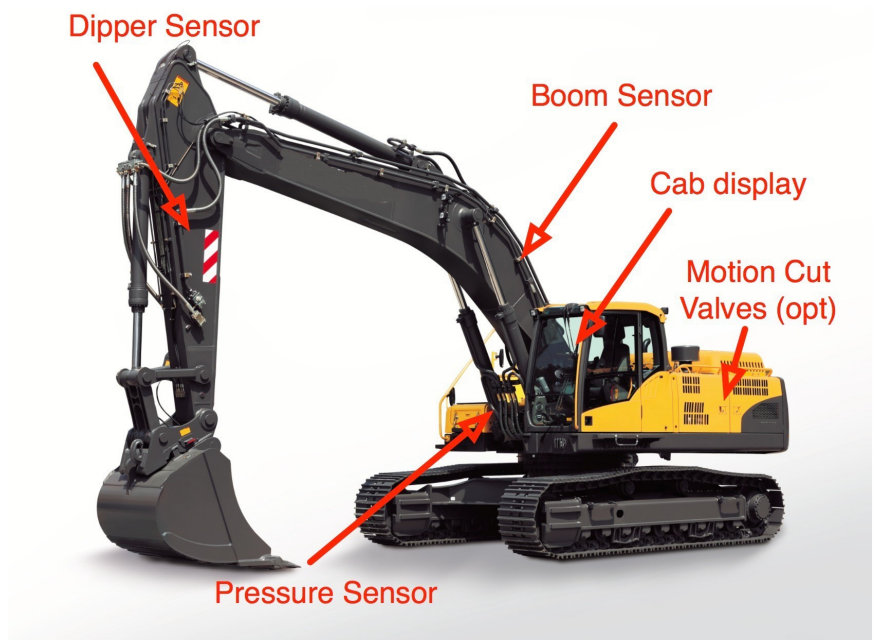

Error codes and error diagnosis guide

The system diagnostics continually monitor all of the system components for correct operation. If there is a problem, the system will show an error message on the display in a red background and if appropriate sound the alarm. Below is a link to the GKD Knowledge base where you can find definitions of all the error codes for the 2RCI System.

helpdesk.gkdtechnik.com/kb

Alternatively, contact GKD Technologies on:

+44 (0) 1202 861961

+44 (0) 1202 971971

service@gkdtec.com

www.gkdtec.com

**GKD Technik reserve the right to change these instructions in line
with the policy of continuous improvement.**