



pRP6

pRP7

pRP8

RealPiano
DIGITAL

Pianovelle



1st edition december 2000

SERVICE MANUAL

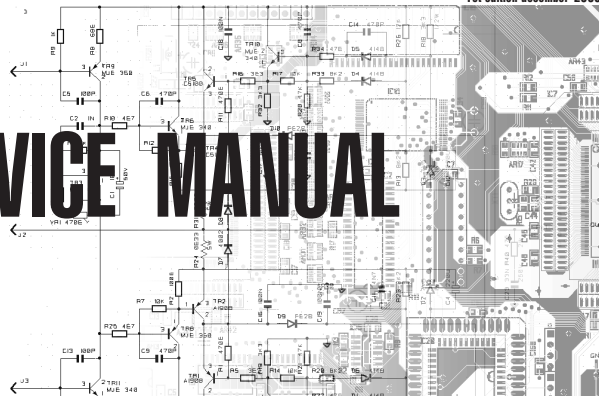

▶ CODE: 270245 ◀

Index

- 2 pRP6 Opening Instructions.
- 3 pRP7 and pRP8 Opening Instructions.
- 4 pRP6, pRP7 and pRP8 Test Procedures.
- 5 Timing Table, pRP6 Block Diagram.
- 6 pRP7 and pRP8 Block Diagrams.
- 7 Controls Panel and Display Boards, I/O Amplifier & Supply Boards.
- 8 L/R Contact, Keyboard Interface Board.
- 9 pRP6 Cpu & Sound Generator Board.
- 10 pRP7 and pRP8 Cpu & Sound Generator Board.
- 11 Spare Part List.

Warnings



Notice

Service must be carried out by qualified personnel only. Any tampering carried out by unqualified personnel during the guarantee period will forfeit the right to guarantee.

For a correct operation of the instrument, after having switched off, be careful to wait at least 3 seconds before switching on again. To improve the device's specifications, the schematic diagrams may be subject to change without prior notice.

All components marked by this symbol have special safety characteristics, when replacing any of these components use only manufacturer's specified parts.

The (μ) micro symbol of capacitance value is substituted by U.

The (Ω) omega symbol of resistance value is substituted by E.

The electrolytic capacitors are 25Vdc rated voltage unless otherwise specified.

All resistors are 1/8W unless otherwise specified.

All switches shown in the "OFF" position. All DC voltages measured to ground with a voltmeter 20KOhm/V.

⚡ Supply voltage. ⚡ Logic supply ground.

⚡ Mate connector. ⚡ Test point. ⚡ Analog supply ground.

♀ Female connector. ⚡ Flag joined with one or more flags with the same signal name inscribed. ⚡ Chassis ground.

♂ M/F faston connector. ⚡ Earth ground.



ATTENTION

Observe precautions when handling electrostatic sensitive devices.

Address



GENERALMUSIC S.p.A. Sales Division: 47842 S.Giovanni in Marignano (RN) ITALY - Via delle Rose, 12



Phone +39(0)541/959511 - Fax +39(0)541/957404 - GENERALMUSIC on the NET: <http://www.generalmusic.com>

PRP6 Opening Instructions



Fig.1 Unscrew the 9 fixing screws (A) and move the front panel towards you and lift it up .



Fig.2 To remove the keyboard unscrew the 10 fixing screws (B) underneath it.

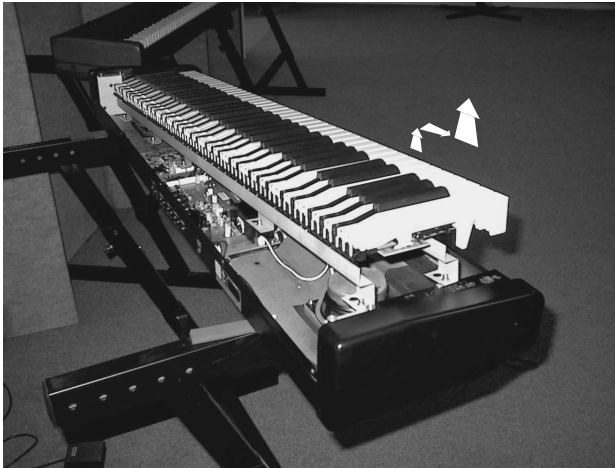

Fig.3 To remove the keyboard lift it up some centimeters from the left end only, shift it to the left how it is sufficient to free the right side and extract it entirely. Note: The attraction of the speaker magnetic core can cause some difficulty.



Fig.4 BE CAREFUL: disconnect the keyboard cable (C) without forcing it when you remove the keyboard, to connect the keyboard out of the chassis is needed a longest cable (GM ordering code 840532).

BMW MOCOARD	BMW 30000	FCM	GENERALMOTO S.p.A. (RM)
CAD. N°178	DISC. PREL. 3/1	PRP6	ALTERNATIVE DESIGN SCHEMES
APP. MOCARD	REV. 23/10/02	OPENING INSTRUCTIONS	DESIGNER: MOCARD/GENERALMOTO DRAWING CREAT. BY: GENERALMOTO

pRP7 Opening Instructions



Fig.1 Unscrew the 9 fixing screws (A) and move the front panel towards you and lift it up .



Fig.2 To remove the keyboard unscrew the 11 fixing screws (B) underneath it.

pRP8 Opening Instructions



Fig.1 Unscrew the 9 fixing screws (A) and move the front panel towards you and lift it up .



Fig.2 To remove the keyboard unscrew the 11 fixing screws (B) underneath it.

DEW DOCUMENT	DEW-200003	17001	GENERAL MUSIC S.p.A. ITALY
DEW USER	DEW-1981-011	PRO718	ALL RIGHTS ARE RESERVED TO COMPANY
APP. MODIFICATION	REV. 001/0006	OPENING INSTRUCTIONS	FOR INFORMATION AND DOCUMENTATION PURPOSES

pRP6 TEST PROCEDURE

This procedure are not intended to repair a fault but only to check the proper instrument operations after a repairing execution. The procedures that follow must be executed in the order specified.

Instrument and Tools

- 1) Dual trace oscilloscope (Note: the Oscilloscope must be earth insulated).
- 2) Sinusoidal signal generator.
- 3) Digital Multimeter.
- 4) N.1 Midi cable.
- 5) N.1 Stereo jack plug.
- 6) N.2 Mono jack plug.

Setup

- Insert the mono jacks into the LEFT and RIGHT OUTPUTS.
- Check jumper positions: for pRP6 none must be shorted.

Supplies Check

- Check with the Multimeter the following voltages on "Cpu & Sound Generator Board":
- Switch off
- CN7 pin1-4 = +3.6Vdc (+VBAT for memory backup)
- Switch on
- CN7 pin1-4 = +4.8Vdc (+VBAT for battery recharging)
- CN7 pin1-5 = +5Vdc (+5VB for analog DAC supply)
- CN8 pin2-4 = +5Vdc (+5V for digital supply)

Memory and System Reset

- To Re-set the instrument press the two SOUND/DATA buttons while holding pressed the GRAND PIANO button. The Led turns off and after some seconds lights on again. This operation clear all data in memory.

Speakers Check

- Press and hold C6 note key and then GRAND PIANO and SOUND/DATA UP buttons: playing a note (OBOE preset) it must be heard from right speaker.
- Press and hold D6 note key and then GRAND PIANO and SOUND/DATA UP buttons: playing a note (OBOE preset) it must be heard from left speaker.

Right & Left Output Levels Check

- Check the levels as follow:
- Set the VOLUME at max.
- Connect the probes of the oscilloscope between the pins of the speakers, set them at 1ms/div. 5V/div.
- Press and hold E6 note key then GRAND PIANO and SOUND/DATA UP button: Play the C5 note (OBOE preset) with the maximum dynamic, the note must be heard from each speaker without distortions or oscillations, the level displayed on the oscilloscope screen must be 17.5±1Vpp.
- Connect the two probe tips of the oscilloscope to the tip and ring contacts of the stereo jack plug plugged into PHONES and a ground clip to the sleeve of the same jack plug; set it at 1ms/div. 1V/div.
- Play the C5 note with the maximum dynamic, the level displayed on the oscilloscope screen must be 4.2±0.1Vpp.
- Connect the first trace of the oscilloscope to the tip and sleeve contacts of the mono jack plugged into RIGHT OUTPUT, set it at 1ms/div. 0.5V/div.
- Connect the other trace of the oscilloscope to the tip and sleeve contacts of the stereo jack plugged into LEFT OUTPUT, set it at 1ms/div. 0.5V/div.
- Play the C5 note with the maximum dynamic, the level displayed on the oscilloscope screen must be 1.6±0.2Vpp.

Right & Left Inputs Levels Check

- Check the levels as follow:
- Set the sinusoidal generator at 1KHz 400mVpp.
- Connect the generator to the RIGHT INPUT.
- Set the oscilloscope at 2ms/div. 0.2V/div.
- A sinusoidal signal of 1±0.1Vpp must be showed on the scope screen.
- Also check the LEFT INPUT.

Pedals Check

- Plug the switch pedals into the DAMPER JACK socket, press down the pedal and then press a note key: the instrument plays the note, release the note key and the sound holds on, release the pedal and the sound shuts off.
- Plug the switch pedals into the PEDAL JACK socket, press a note key while pressing the pedal the sound is more soft.

Midi In/Out Check

- Set the Local OFF pressing and holding F7 note key and then SOUND/DATA DOWN button.
- Playing some notes you do not hear sound, connect the midi cable between MIDI IN and OUT sockets, play again and now the instrument sound.
- Restore the Local On pressing and holding F7 note key and then SOUND/DATA UP button.

Reliability Check

Before reassembling the instrument and before return it to the user, it is a goal verify its reliability: Leaving it switched on and operating with greatest caution, carefully shake the boards and connections using an insulated tool to find faulty contacts, bad solderings and so on, at the same time verify the instrument working. Start the Demo pressing the two SOUND/VARIATIONS buttons simultaneously, finally leave it switched on for a long time verifying its functionality occasionally.

pRP7 TEST PROCEDURE

This procedure are not intended to repair a fault but only to check the proper instrument operations after a repairing execution. The procedures that follow must be executed in the order specified.

Instrument and Tools

- 1) Dual trace oscilloscope (Note: the Oscilloscope must be earth insulated).
- 2) Sinusoidal signal generator.
- 3) Digital Multimeter.
- 4) N.1 Midi cable.
- 5) N.1 Stereo jack plug.
- 6) N.2 Mono jack plug.

Setup

- Insert the mono jacks into the LEFT and RIGHT OUTPUTS.
- Check jumper positions: for pRP7 J3 is shorted and J2 is open.

Supplies Check

- Check with the Multimeter the following voltages on "Cpu & Sound Generator Board":
- Switch off
- CN7 pin1-4 = +3.6Vdc (+VBAT for memory backup)
- Switch on
- CN7 pin1-4 = +4.8Vdc (+VBAT for battery recharging)
- CN7 pin1-5 = +5Vdc (+5VB for analog DAC supply)
- CN8 pin2-4 = +5Vdc (+5V for digital supply)

Memory and System Reset

- To Re-set the instrument press the two SOUND/VARIATIONS buttons while holding pressed the GRAND PIANO button. All Leds turn off and after some seconds light on again. This operation clear all data in memory.

Speakers Check

- Press and hold A6 note key and then GRAND PIANO and TEMPO/DATA UP buttons: playing a note (OBOE preset) it must be heard from right speaker.
- Press and hold G6 note key and then GRAND PIANO and TEMPO/DATA UP buttons: playing a note (OBOE preset) it must be heard from left speaker.

Right & Left Output Levels Check

- Check the levels as follow:
- Set the VOLUME at max.
- Connect the two probe tips of the oscilloscope to the tip and ring contacts of the stereo jack plug plugged into PHONES and a ground clip to the sleeve of the same jack plug; set it at 1ms/div. 1V/div.
- Press and hold B6 note key then GRAND PIANO and TEMPO/DATA UP button: Play the C5 note (OBOE preset) with the maximum dynamic, the level displayed on the oscilloscope screen must be 4.2±0.1Vpp.
- Connect the first trace of the oscilloscope to the tip and sleeve contacts of the mono jack plugged into RIGHT OUTPUT, set it at 1ms/div. 0.5V/div.
- Connect the other trace of the oscilloscope to the tip and sleeve contacts of the stereo jack plugged into LEFT OUTPUT, set it at 1ms/div. 0.5V/div.
- Play the C5 note with the maximum dynamic, the level displayed on the oscilloscope screen must be 1.6±0.2Vpp.

Right & Left Inputs Levels Check

- Check the levels as follow:
- Set the sinusoidal generator at 1KHz 400mVpp.
- Connect the generator to the RIGHT INPUT.
- Set the oscilloscope at 2ms/div. 0.2V/div.
- A sinusoidal signal of 1±0.1Vpp must be showed on the scope screen.
- Also check the LEFT INPUT.

Pedals Check

- Plug the switch pedals into the DAMPER JACK socket, press down the pedal and then press a note key: the instrument plays the note, release the note key and the sound holds on, release the pedal and the sound shuts off.
- Plug the switch pedals into the PEDAL JACK socket, press a note key while pressing the pedal the sound is more soft.

Midi In/Out Check

- Set the Local OFF pressing and holding B7 note key and then TEMPO/DATA DOWN button.
- Playing some notes you do not hear sound, connect the midi cable between MIDI IN and OUT sockets, play again and now the instrument sound.
- Restore the Local On pressing and holding B7 note key and then TEMPO/DATA UP button.

Reliability Check

Before reassembling the instrument and before return it to the user, it is a goal verify its reliability: Leaving it switched on and operating with greatest caution, carefully shake the boards and connections using an insulated tool to find faulty contacts, bad solderings and so on, at the same time verify the instrument working. Start the Demo pressing the two SOUND/VARIATIONS buttons simultaneously, finally leave it switched on for a long time verifying its functionality occasionally.

pRP8 TEST PROCEDURE

This procedure are not intended to repair a fault but only to check the proper instrument operations after a repairing execution. The procedures that follow must be executed in the order specified.

Instrument and Tools

- 1) Dual trace oscilloscope (Note: the Oscilloscope must be earth insulated).
- 2) Sinusoidal signal generator.
- 3) Digital Multimeter.
- 4) N.1 Midi cable.
- 5) N.1 Stereo jack plug.
- 6) N.2 Mono jack plug.

Setup

- Insert the mono jacks into the LEFT and RIGHT OUTPUTS.
- Check jumper positions: for pRP8 J3 is shorted and J3 is open.

Supplies Check

- Check with the Multimeter the following voltages on "Cpu & Sound Generator Board":
- Switch off
- CN7 pin1-4 = +3.6Vdc (+VBAT for memory backup)
- Switch on
- CN7 pin1-4 = +4.8Vdc (+VBAT for battery recharging)
- CN7 pin1-5 = +5Vdc (+5VB for analog DAC supply)
- CN8 pin2-4 = +5Vdc (+5V for digital supply)

Memory and System Reset

- To Re-set the instrument press the two SOUND/VARIATIONS buttons while holding pressed the GRAND PIANO button. All Leds turn off and after some seconds light on again. This operation clear all data in memory.

Speakers Check

- Press and hold A6 note key and then GRAND PIANO and TEMPO/DATA UP buttons: playing a note (OBOE preset) it must be heard from right speaker.
- Press and hold G6 note key and then GRAND PIANO and TEMPO/DATA UP buttons: playing a note (OBOE preset) it must be heard from left speaker.

Right & Left Output Levels Check

- Check the levels as follow:
- Set the VOLUME at max.
- Connect the probes of the oscilloscope between the pins of the speakers, set them at 1ms/div. 5V/div.
- Press and hold B6 note key then GRAND PIANO and TEMPO/DATA UP button: Play the C5 note (OBOE preset) with the maximum dynamic, the note must be heard from each speaker without distortions or oscillations, the level displayed on the oscilloscope screen must be 17.5±1Vpp.
- Connect the two probe tips of the oscilloscope to the tip and ring contacts of the stereo jack plug plugged into PHONES and a ground clip to the sleeve of the same jack plug; set it at 1ms/div. 1V/div.
- Play the C5 note with the maximum dynamic, the level displayed on the oscilloscope screen must be 4.2±0.1Vpp.
- Connect the first trace of the oscilloscope to the tip and sleeve contacts of the mono jack plugged into RIGHT OUTPUT, set it at 1ms/div. 0.5V/div.
- Connect the other trace of the oscilloscope to the tip and sleeve contacts of the stereo jack plugged into LEFT OUTPUT, set it at 1ms/div. 0.5V/div.
- Play the C5 note with the maximum dynamic, the level displayed on the oscilloscope screen must be 1.6±0.2Vpp.

Right & Left Inputs Levels Check

- Check the levels as follow:
- Set the sinusoidal generator at 1KHz 400mVpp.
- Connect the generator to the RIGHT INPUT.
- Set the oscilloscope at 2ms/div. 0.2V/div.
- A sinusoidal signal of 1±0.1Vpp must be showed on the scope screen.
- Also check the LEFT INPUT.

Pedals Check

- Plug the switch pedals into the DAMPER JACK socket, press down the pedal and then press a note key: the instrument plays the note, release the note key and the sound holds on, release the pedal and the sound shuts off.
- Plug the switch pedals into the PEDAL JACK socket, press a note key while pressing the pedal the sound is more soft.

Midi In/Out Check

- Set the Local OFF pressing and holding B7 note key and then TEMPO/DATA DOWN button.
- Playing some notes you do not hear sound, connect the midi cable between MIDI IN and OUT sockets, play again and now the instrument sound.
- Restore the Local On pressing and holding B7 note key and then TEMPO/DATA UP button.

Reliability Check

Before reassembling the instrument and before return it to the user, it is a goal verify its reliability: Leaving it switched on and operating with greatest caution, carefully shake the boards and connections using an insulated tool to find faulty contacts, bad solderings and so on, at the same time verify the instrument working. Start the Demo pressing the two SOUND/VARIATIONS buttons simultaneously, finally leave it switched on for a long time verifying its functionality occasionally.

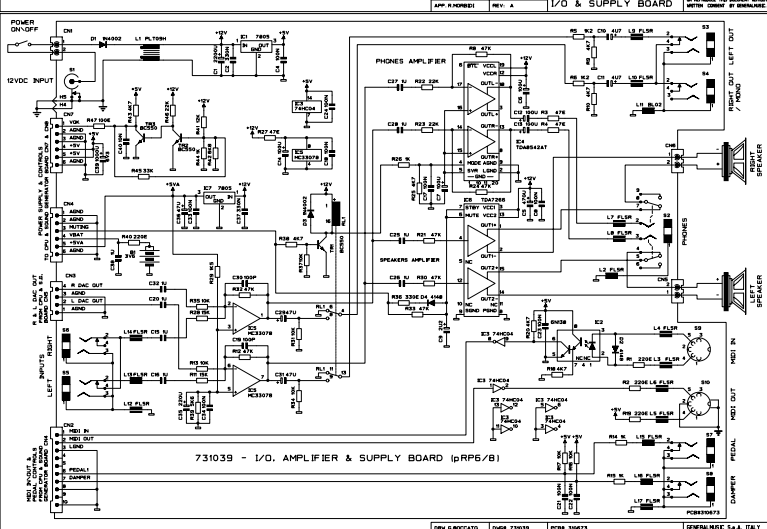
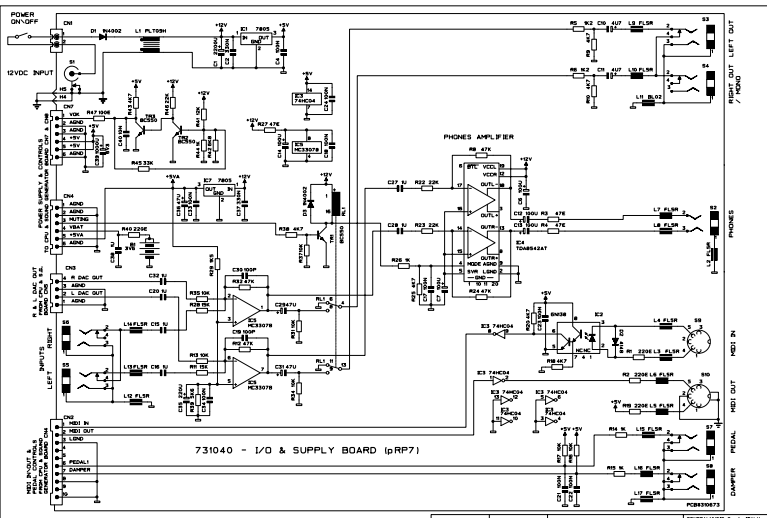
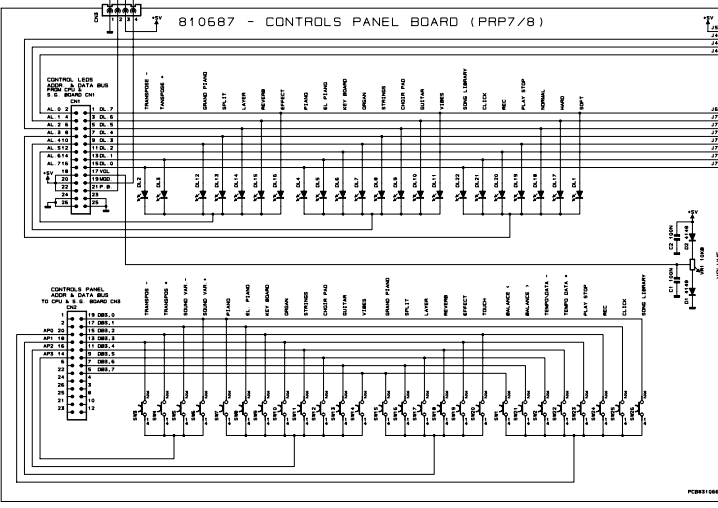
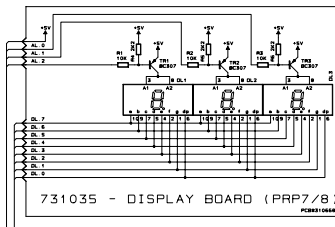
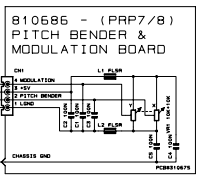
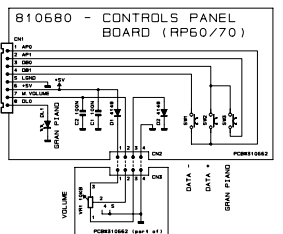

DW G. BACCATO DWB 30024 PWB 310680, 310686, 310687, 310688
 DW 3 10794 DATE 11-12-50
 APP. R. MORSEI REV. A
 GENERAL: S. A. ITALY
 ALL RIGHTS RESERVED. NO OTHER
 REPRODUCTION PERMITTED WITHOUT
 WRITTEN CONSENT BY GENERAL:

DW G. BACCATO DWB 30024 PWB 310680
 DW 3 10794 DATE 11-12-50
 APP. R. MORSEI REV. A
 GENERAL: S. A. ITALY
 ALL RIGHTS RESERVED. NO OTHER
 REPRODUCTION PERMITTED WITHOUT
 WRITTEN CONSENT BY GENERAL:

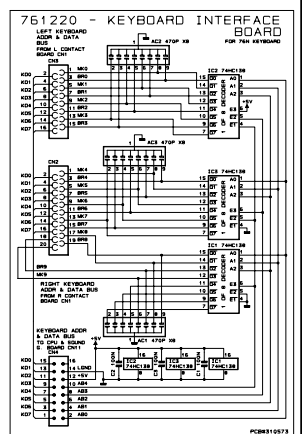
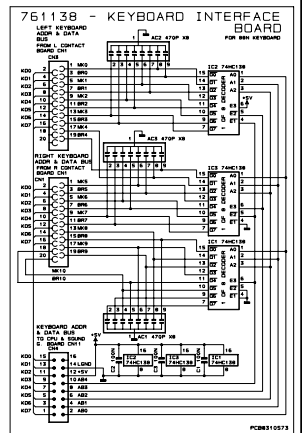
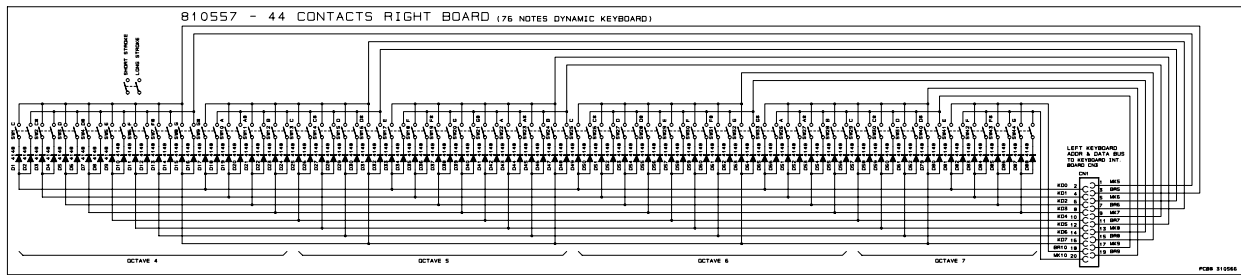
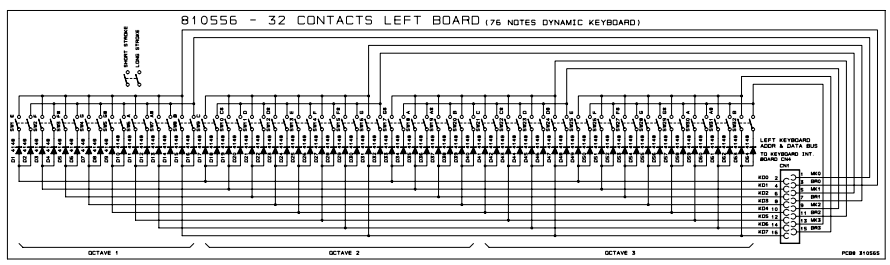
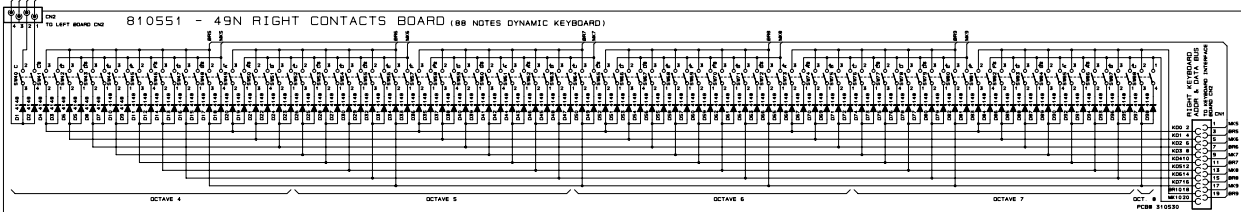
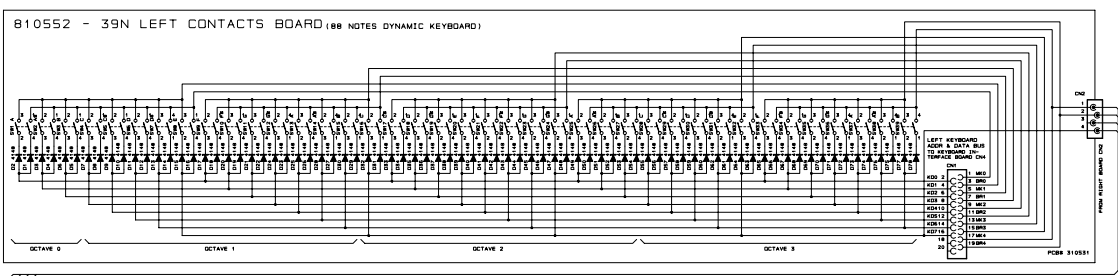

REV	DESCRIPTION	DATE	BY	CHKD	APP	APPROVED
001	REVISED	11/12/2017
002
003
004
005
006
007
008
009
010
011
012
013
014
015
016
017
018
019
020
021
022
023
024
025
026
027
028
029
030
031
032
033
034
035
036
037
038
039
040
041
042
043
044
045
046
047
048
049
050
051
052
053
054
055
056
057
058
059
060
061
062
063
064
065
066
067
068
069
070
071
072
073
074
075
076
077
078
079
080
081
082
083
084
085
086
087
088
089
090
091
092
093
094
095
096
097
098
099
100

761221 - CPU & SOUND GENERATOR BOARD (pRP6)

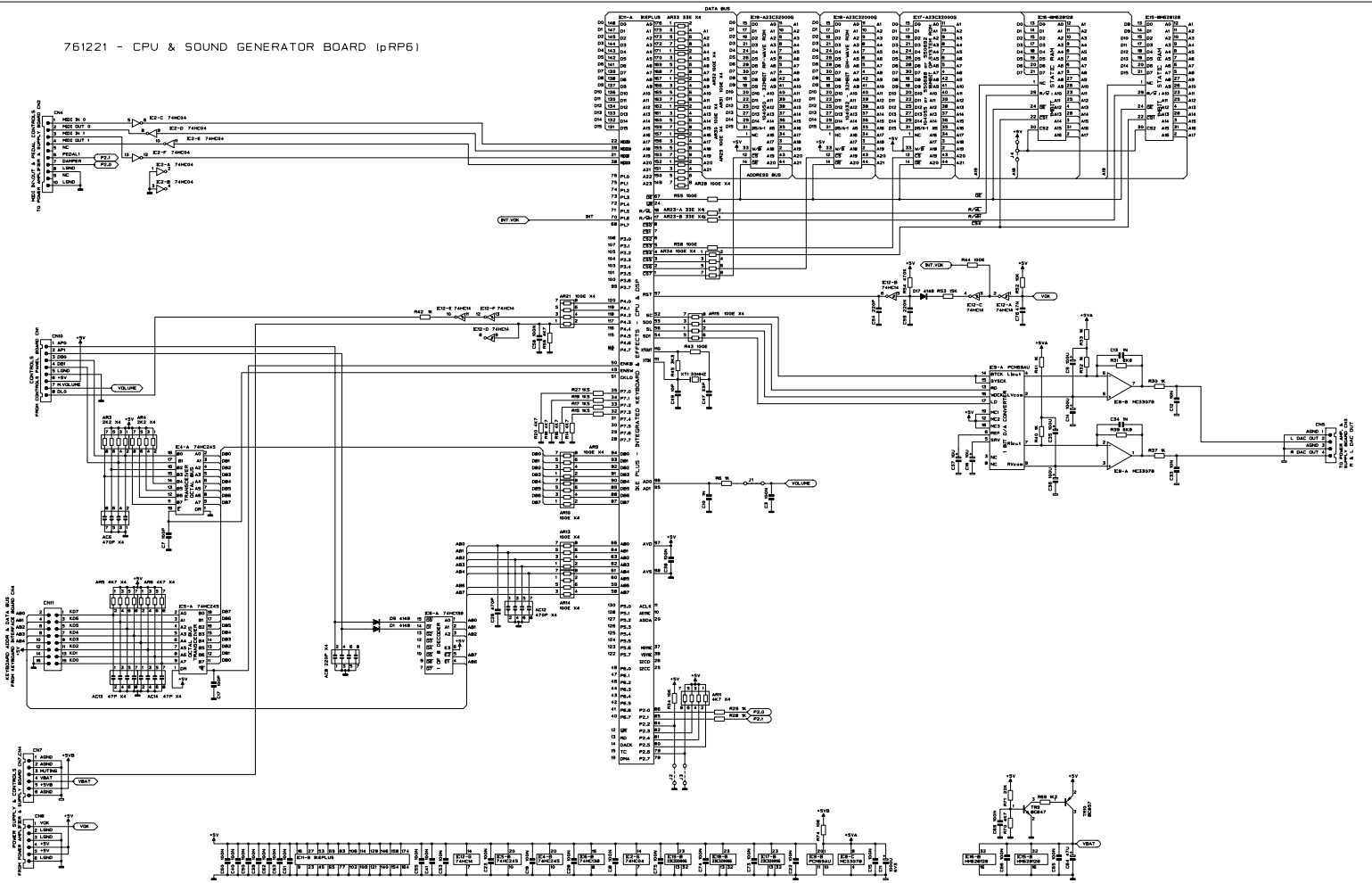

DES. N. 800240	DATE 10/09/85	FORM 310077	GERELANCE S.p.A. FILE
DES. L. 1076	DATA 10/09/85	SCHEMATIC DRAWING 6RP6	ALTERNATIVE VERSIONS OF CIRCUIT
APP. NUMBER: REV. A		CPU & SOUND GENERATOR BOARD	OR REPLACE THE ORIGINAL WHEN NECESSARY. CHECK THE PART NUMBER.

761219 - CPU & SOUND GENERATOR BOARD (pRP7/8)

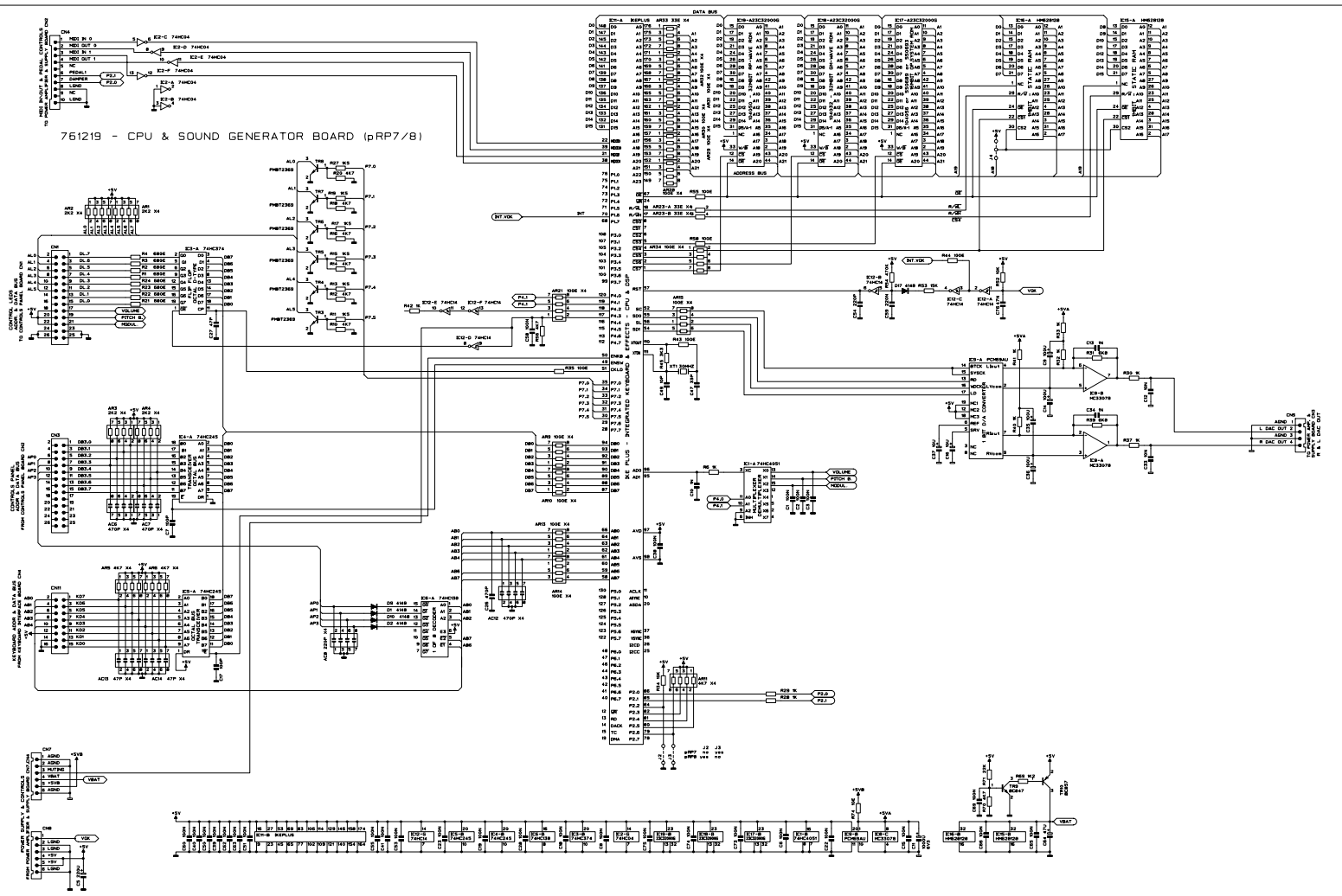

APP. SUBMITTED	DATE 09/08/80	FORM 10/07/77	GENERALIZATION: S.A. DELT
DES. I. STATE	DATE 08/09/80	SCHEMATIC DESIGN (RP7/8)	IN ORDER AND SUBJECT TO CHECK
APP. NUMBER	REV. A	CPU & SOUND GENERATOR BOARD	OR APPROVED FOR PRODUCTION UNDER

