

SPLIT TYPE  
ROOM AIR CONDITIONER  
WALL MOUNTED TYPE

# SERVICE MANUAL



Indoor unit	Outdoor unit
ASYG18LFCA	AOYG18LFC

## CONTENTS

SPECIFICATIONS . . . . .	1
DIMENSIONS . . . . .	2
REFRIGERANT SYSTEM DIAGRAM . . . . .	3
CIRCUIT DIAGRAM . . . . .	4
INDOOR PCB CIRCUIT DIAGRAM . . . . .	5
OUTDOOR PCB CIRCUIT DIAGRAM . . . . .	8
ERROR DETECTION . . . . .	10
PARTS (INDOOR UNIT) . . . . .	11
PARTS (OUTDOOR UNIT) . . . . .	15
ACCESSORIES . . . . .	18

# SPECIFICATIONS

## ELECTRICAL DATA

INDOOR UNIT	ASYG18LFCA
OUTDOOR UNIT	AOYG18LFC
POWER SOURCE	230 V
FREQUENCY	50 Hz
COOLING CAPACITY	5.20 kW
HEATING CAPACITY	6.30 kW
RUNNING CURRENT (Cool)	6.8 A
RUNNING CURRENT (Heat)	7.6 A
INPUT WATTS (Cooling)	1.52 kW
INPUT WATTS (Heating)	1.71 kW
E.E.R. (Cooling)	3.42 kW/kW
C.O.P. (Heating)	3.68 kW/kW
MAXIMUM CURRENT (Cool)	9.0 A
MAXIMUM CURRENT (Heat)	12.5 A
MOISTURE REMOVAL	2.6 L/hr
AIR CIRCULATION HIGH	900 m <sup>3</sup> /hr

## FAN MOTOR

POWER SOURCE	230 V	
INDOOR UNIT	High	1,220 r.p.m.
	Medium	1,020 r.p.m.
	Low	900 r.p.m.
	Quiet	710 r.p.m.
OUTDOOR UNIT	Cool	920 r.p.m.
	Heat	870 r.p.m.

## NOISE LEVEL

INDOOR UNIT (Cooling)	High	43 dB
	Medium	37 dB
	Low	33 dB
	Quiet	26 dB
INDOOR UNIT (Heating)	High	42 dB
	Medium	37 dB
	Low	33 dB
	Quiet	25 dB
OUTDOOR UNIT (Cool)		50 dB
OUTDOOR UNIT (Heat)		51 dB

## COMPRESSOR AND REFRIGERANT

TYPE	Hermetic type, 4 pole, Rotary, DC inverter motor	
DISCRIMINATION	808 903 80	
WEIGHT (with oil)	9.0 kg	
REFRIGERANT TYPE	R410A	
PRECHARGED REFRIGERANT	1,200 g	
FULL CHARGE	Pipe Length	15 m
		20 m
		25 m
ADDITIONAL CHARGE	20 g/m	
MAX HEIGHT	20 m	

## DIMENSIONS

INDOOR UNIT	H x W x D	320 x 998 x 238 mm
OUTDOOR UNIT	H x W x D	620 x 790 x 290 mm

## WEIGHT

INDOOR UNIT	Shipping / Net	18 kg / 14 kg
OUTDOOR UNIT	Shipping / Net	45 kg / 41 kg

# DIMENSIONS

Unit : mm

## INDOOR UNIT

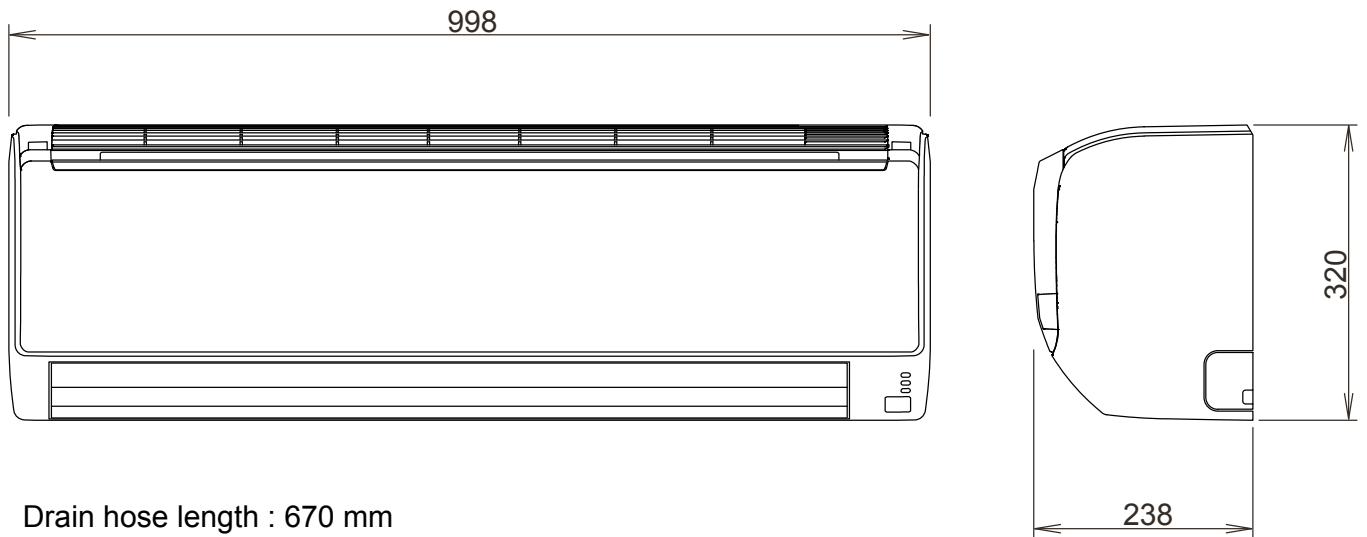

Drain hose length : 670 mm

## OUTDOOR UNIT

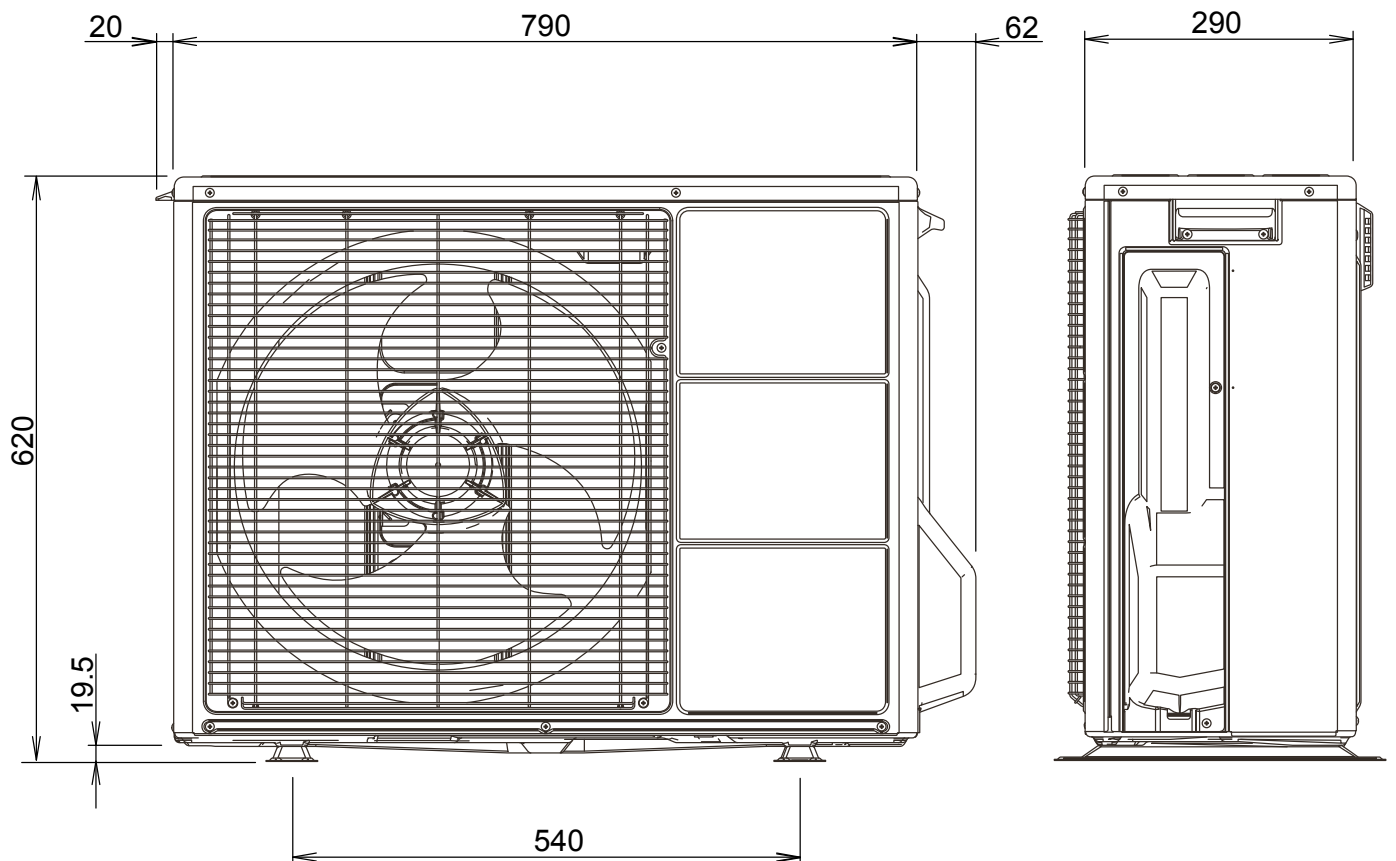

# REFRIGERANT SYSTEM DIAGRAM

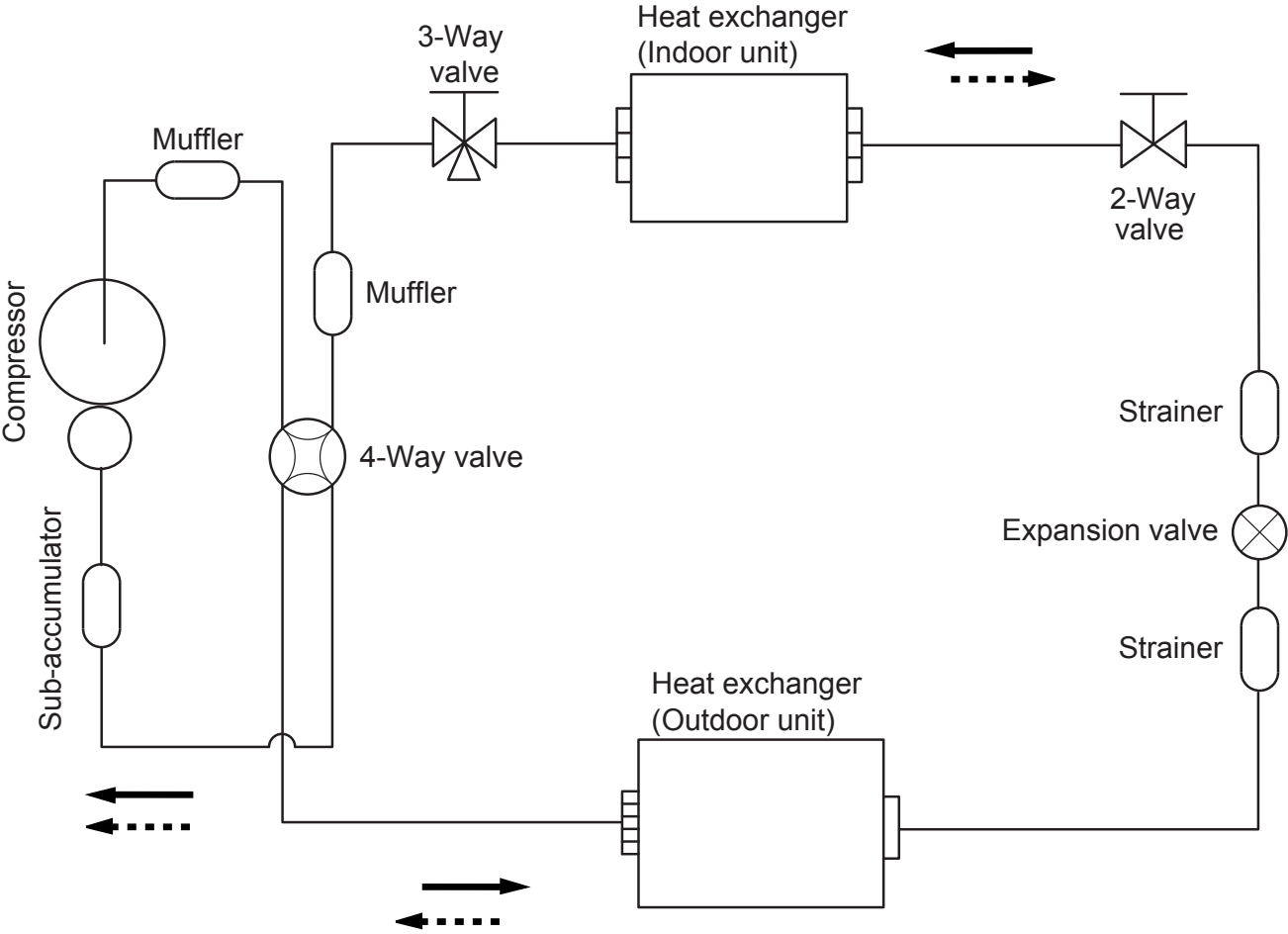

Refrigerant direction

- Cooling
- - - -> Heating

Refrigerant pipe diameter  
 Liquid : 1/4" (6.35 mm)  
 Gas : 1/2" (12.7 mm)

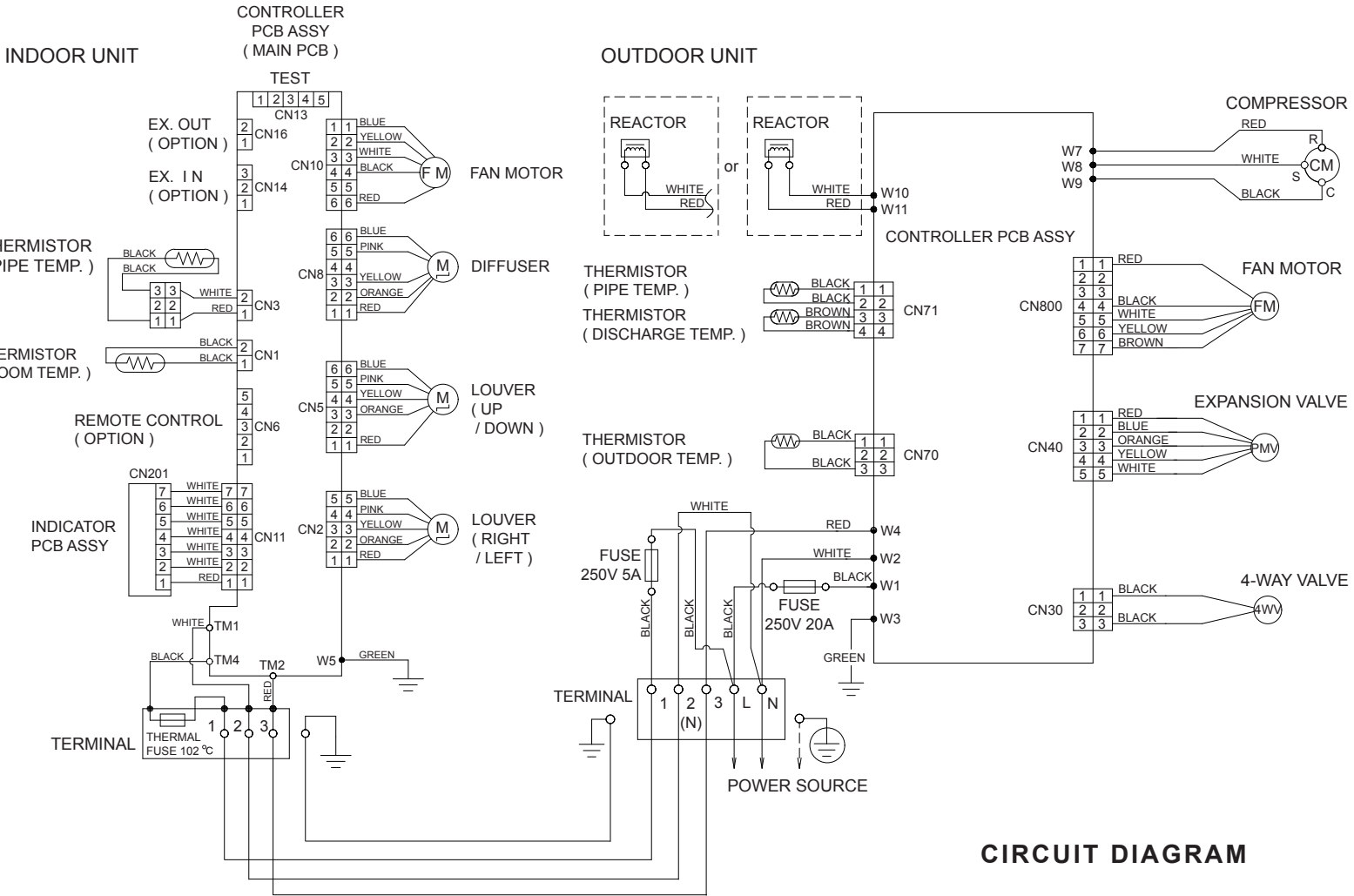

**CIRCUIT DIAGRAM**

**CONTROL UNIT  
EZ-010YHSE**

POWER SOURCE  
AC230V  
50Hz

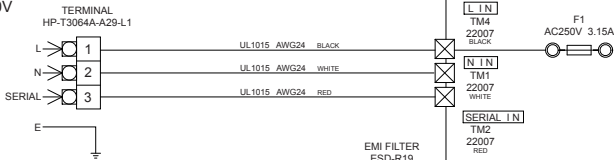

WIRED REMOTE CONTROL  
(OPTION)

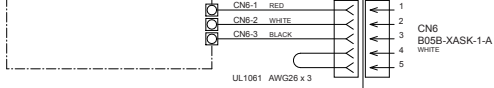

LOUVER ( RIGHT / LEFT )



LOUVER ( UP / DOWN )



LOUVER ( DIFFUSER )

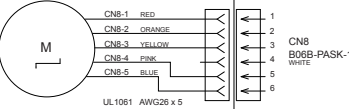

DC FAN MOTOR

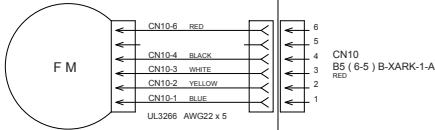

**CONTROLLER PCB ASSEMBLY  
( MAIN PCB )  
K09DR-1001HSE-C1**

**INDOOR PCB  
CIRCUIT DIAGRAM**

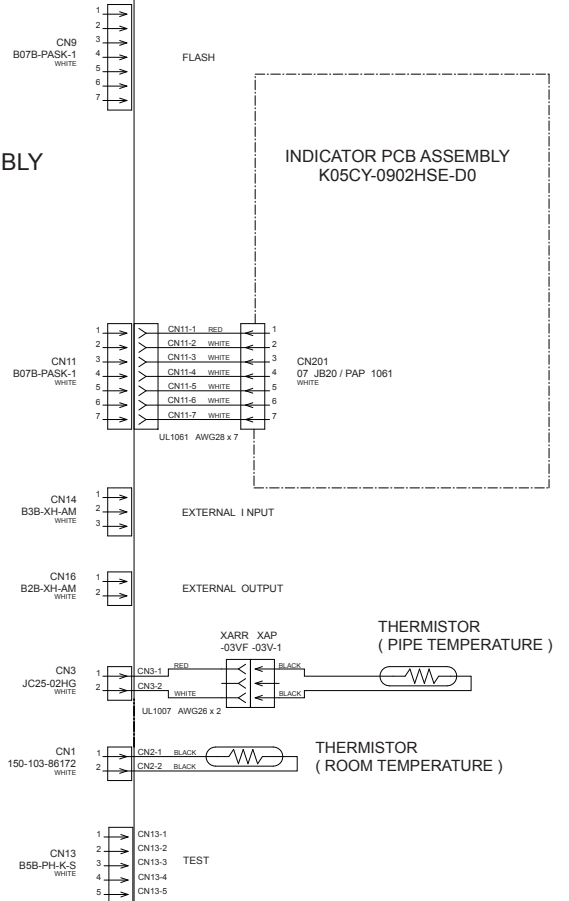

INDOOR UNIT  
 CONTROLLER PCB ASSEMBLY ( MAIN PCB )  
 K09DR-1001HSE-C1

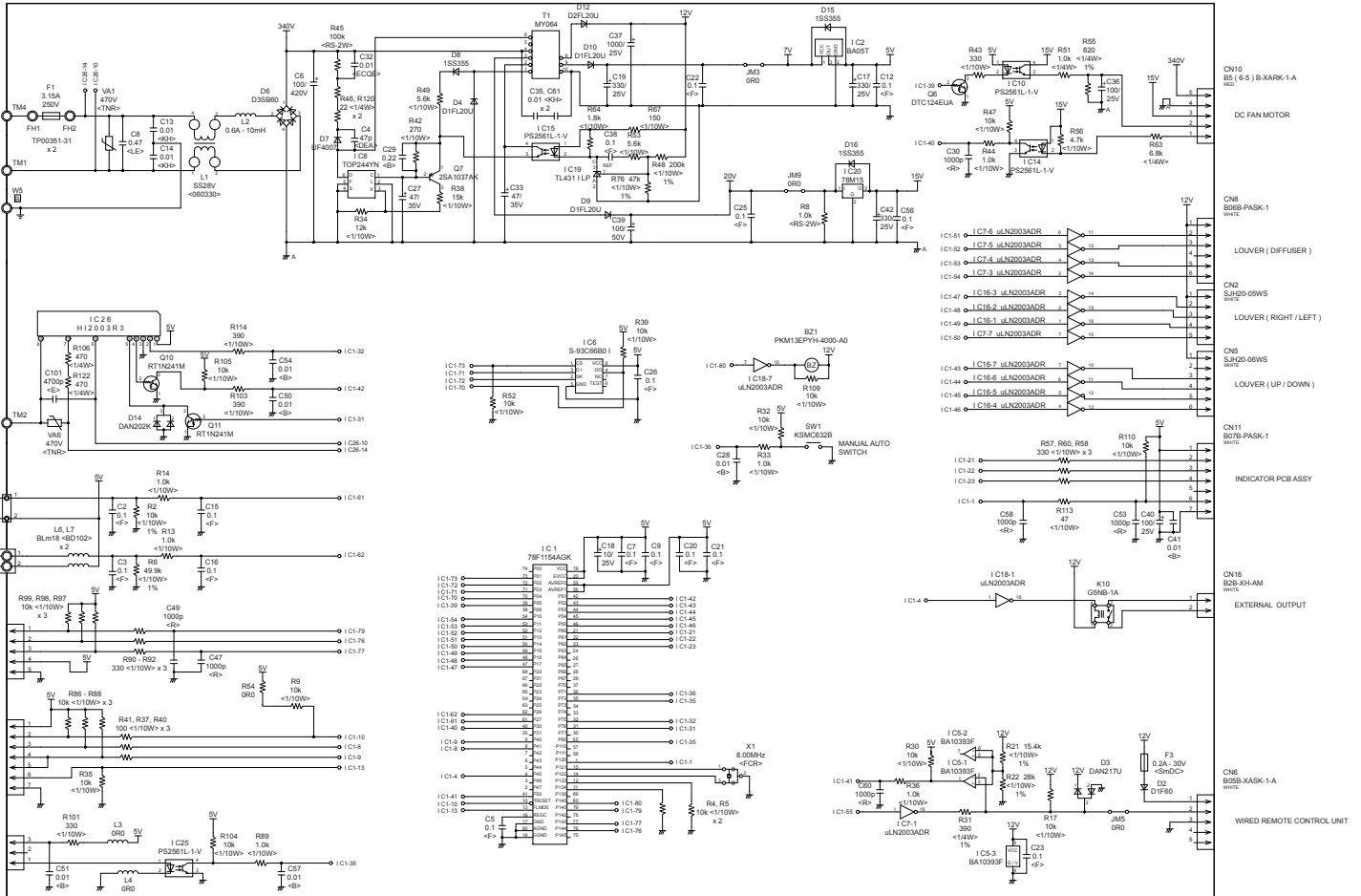

INDOOR UNIT  
 INDICATOR PCB ASSEMBLY  
 K05CY-0902HSE-D0

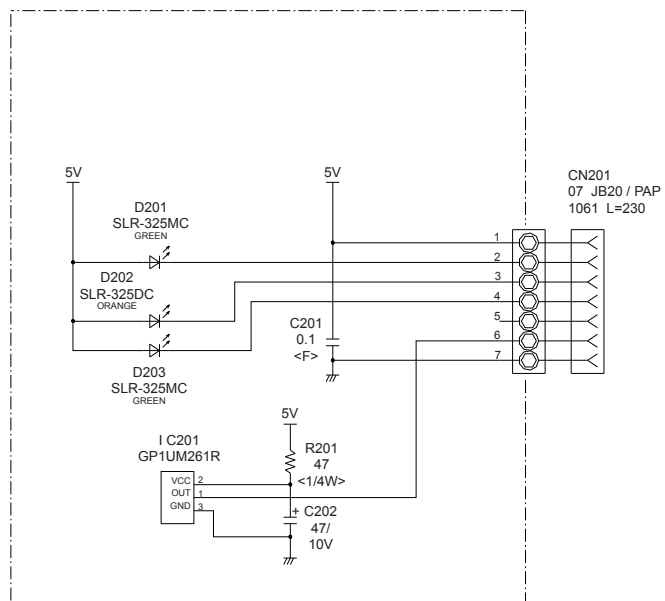



# OUTDOOR PCB CIRCUIT DIAGRAM

## INVERTER ASSEMBLY EZ-0101MHUE

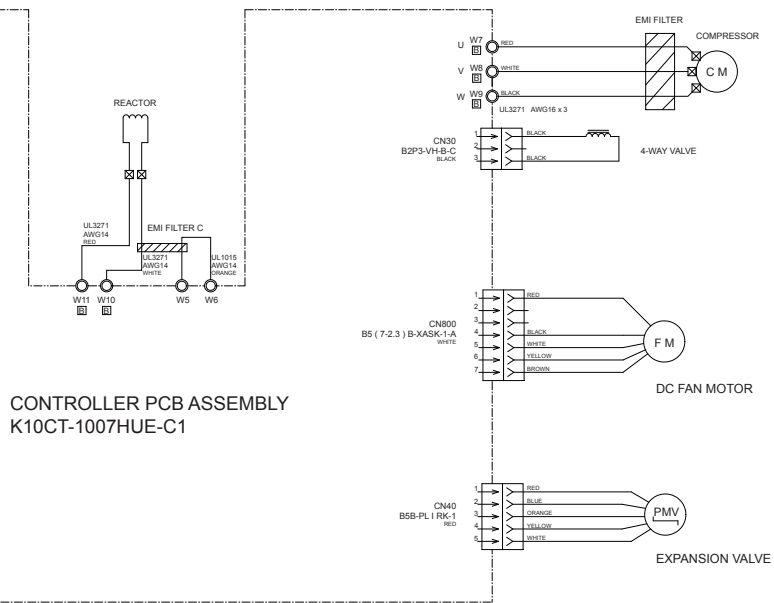
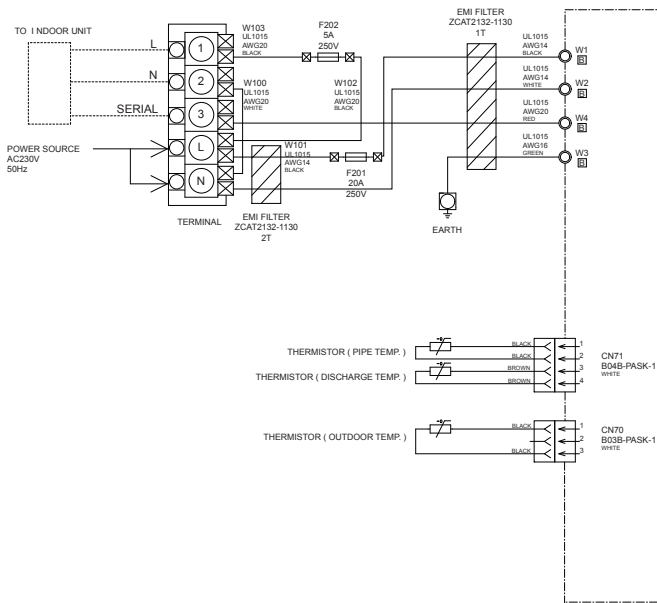

OUTDOOR UNIT  
CONTROLLER PCB ASSEMBLY  
K10CT-1007HUE-C1

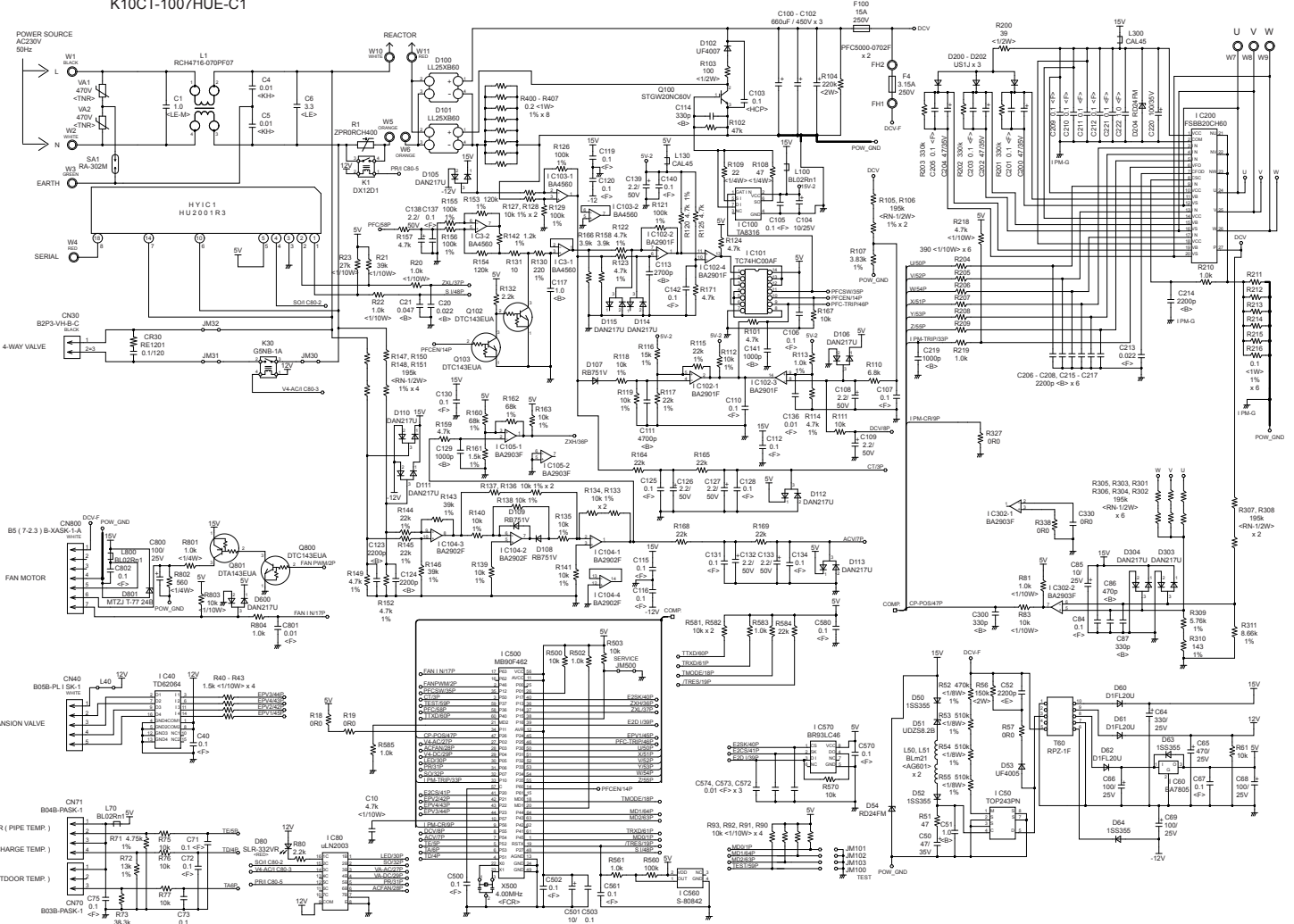

# ERROR DETECTION

## INDOOR UNIT and REMOTE CONTROL

If an error occurs, the following display will be shown.

("Er" will appear in the set room temperature display.)

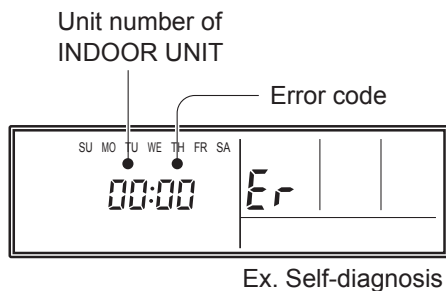

Indoor unit			Wired remote control	Mode	DESCRIPTION
OPERATION lamp (green)	TIMER lamp (orange)	ECO lamp (green)			
● (1)	● (1)	◇	11	Communication	Serial communication error
● (1)	● (2)	◇	12	Communication	Wired remote control communication error
● (2)	● (2)	◇	22	System	Indoor unit capacity error
● (3)	● (1)	◇	31	Indoor unit	Power supply interruption error
● (3)	● (5)	◇	35	Indoor unit	Manual auto switch error
● (3)	● (9)	◇	39	Indoor unit	fan motor driving circuit error
● (4)	● (1)	◇	41	Indoor unit	Inlet air temp. sensor error
● (4)	● (2)	◇	42	Indoor unit	Indoor Heat Ex. Middle Temp. Sensor error
● (5)	● (1)	◇	51	Indoor unit	Indoor unit fan motor1 error
● (5)	● (3)	◇	53	Indoor unit	Drainage error
● (5)	● (9)	◇	59	Indoor unit	Indoor unit fan motor2 error
● (5)	● (15)	◇	5U	Indoor unit	Indoor unit error
● (6)	● (2)	◇	62	Outdoor unit	Outdoor unit model information error
● (6)	● (3)	◇	63	Outdoor unit	Inverter error
● (6)	● (5)	◇	65	Outdoor unit	I.P.M. error
● (7)	● (1)	◇	71	Outdoor unit	Discharge temp. sensor error
● (7)	● (2)	◇	72	Outdoor unit	Compressor temp. sensor error
● (7)	● (3)	◇	73	Outdoor unit	Heat Ex. centre temp. sensor error Heat Ex. Liquid outlet temp. sensor error
● (7)	● (4)	◇	74	Outdoor unit	Outdoor temp. sensor error
● (7)	● (7)	◇	77	Outdoor unit	Heat sink temp. sensor error
● (8)	● (4)	◇	84	Outdoor unit	Current sensor error
● (8)	● (6)	◇	86	Outdoor unit	Pressure sensor error High pressure switch error
● (9)	● (4)	◇	94	Outdoor unit	Over current error
● (9)	● (5)	◇	95	Outdoor unit	Compressor control error
● (9)	● (7)	◇	97	Outdoor unit	Outdoor unit fan motor 1 error
● (9)	● (8)	◇	98	Outdoor unit	Outdoor unit fan motor 2 error
● (9)	● (9)	◇	99	Outdoor unit	4-way valve error
● (10)	● (1)	◇	A1	Refrigerant system	Discharge temp. error
● (10)	● (3)	◇	A3	Refrigerant system	Compressor temp. error
● (10)	● (5)	◇	A5	Refrigerant system	Low pressure error

● : 0.5s ON / 0.5s OFF

◇ : 0.1s ON / 0.1s OFF

( ) : Number of flashing

# PARTS

## INDOOR UNIT

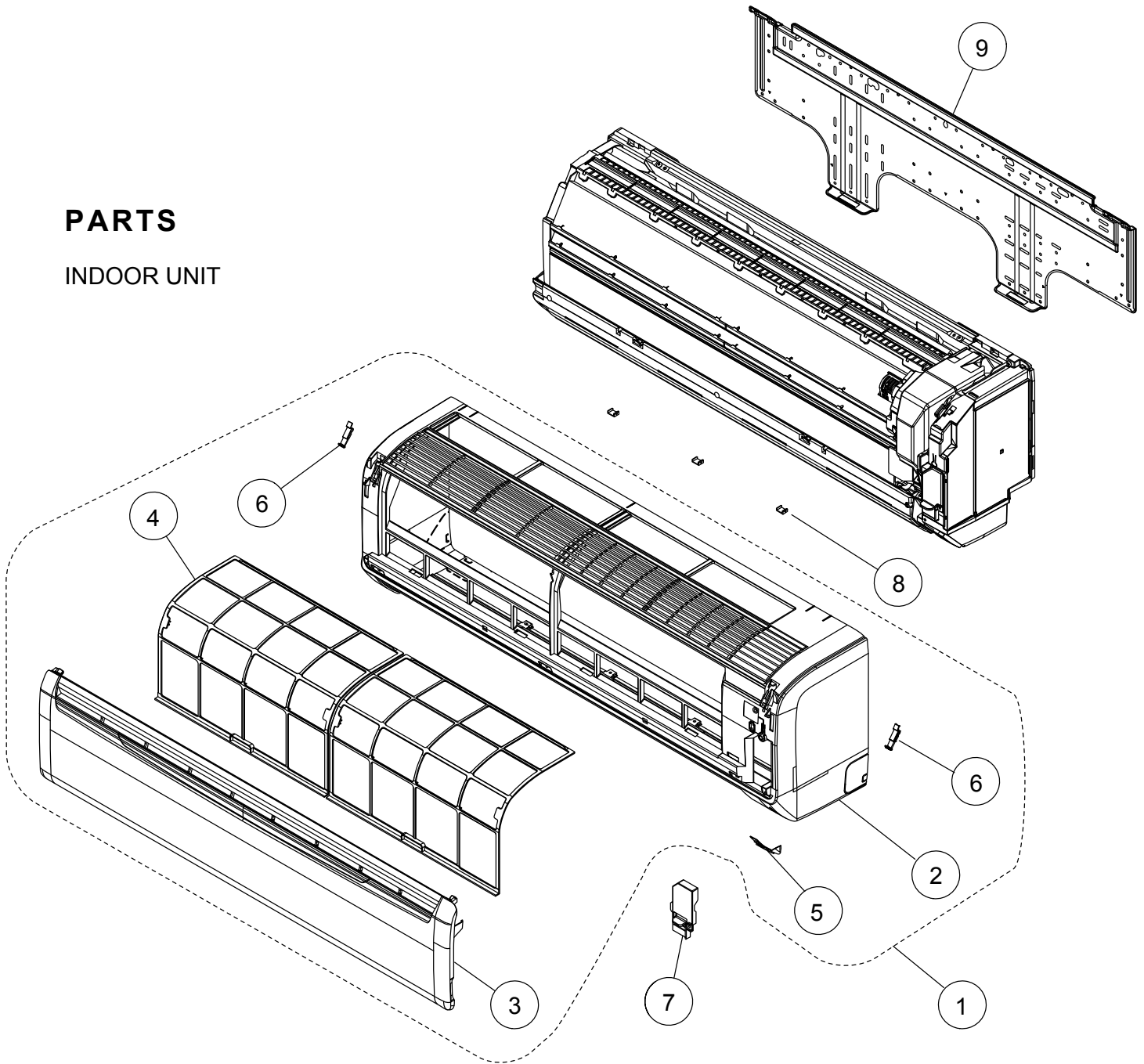

10

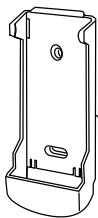

11

Ref	Description	Parts number
1	Front Panel Total Assy	9318738001
2	Front Panel	9314991080
3	Intake Grille Assy	9385985049
4	Air Filter	9315014016
5	Receiver Window	9315010018
6	Clamber Grille	9306755010
7	Wire Clamber	9315015013
8	Cap (Screw)	9309002050
9	Bracket Panel	9315023018
10	Remote Control	9379219037
11	Remote Control Holder	9305642045
--	Air Clean Filter Assy	9315212016

# INDOOR UNIT

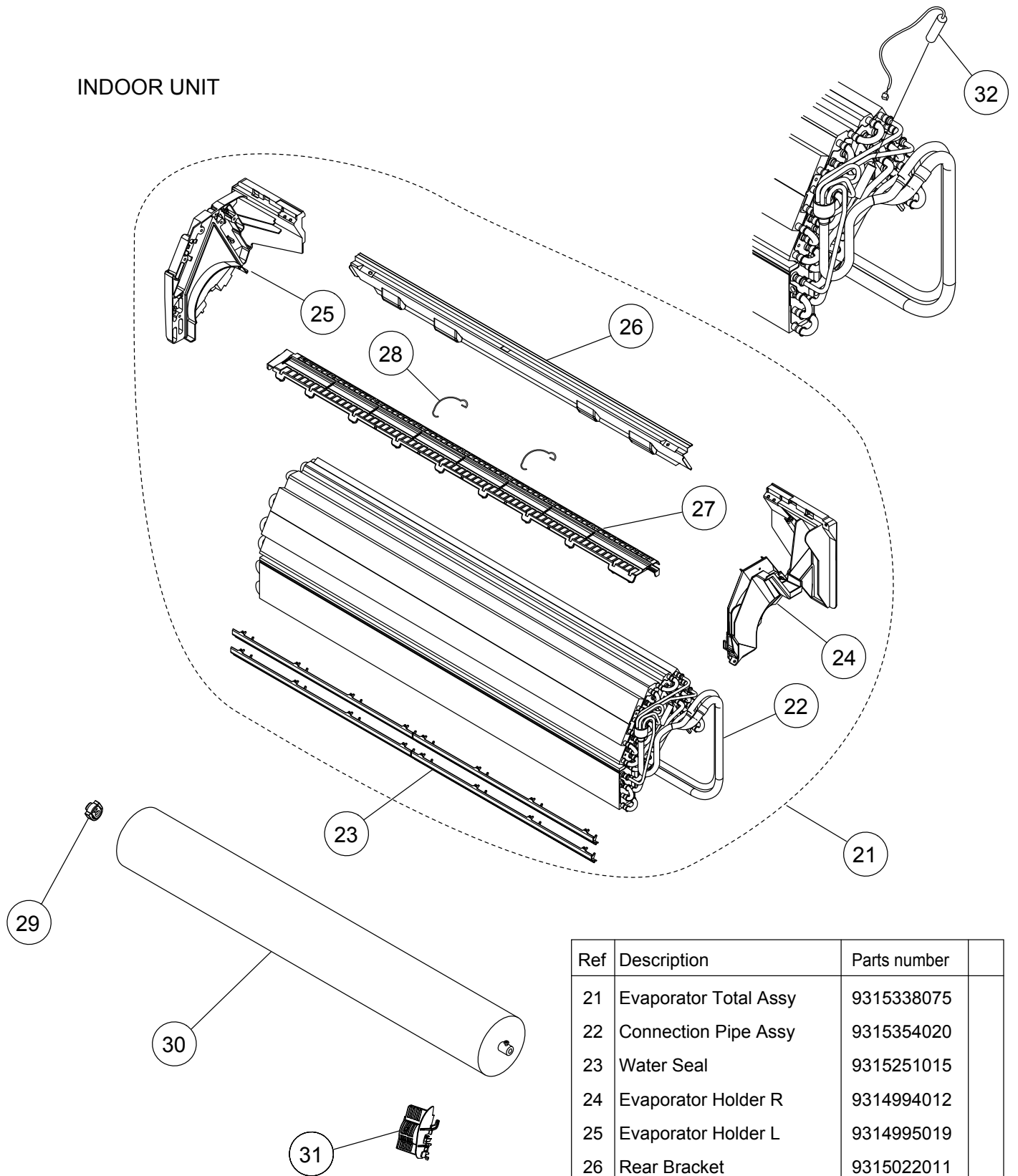

Ref	Description	Parts number
21	Evaporator Total Assy	9315338075
22	Connection Pipe Assy	9315354020
23	Water Seal	9315251015
24	Evaporator Holder R	9314994012
25	Evaporator Holder L	9314995019
26	Rear Bracket	9315022011
27	Filter Guide	9315013019
28	Filter Guard	9315411013
29	Bearing C Assy	9306628017
30	Crossflow Fan Assy	9315024015
31	Holder (Room Thermistor)	9315252012
32	Pipe Thermistor	9900551018

INDOOR UNIT

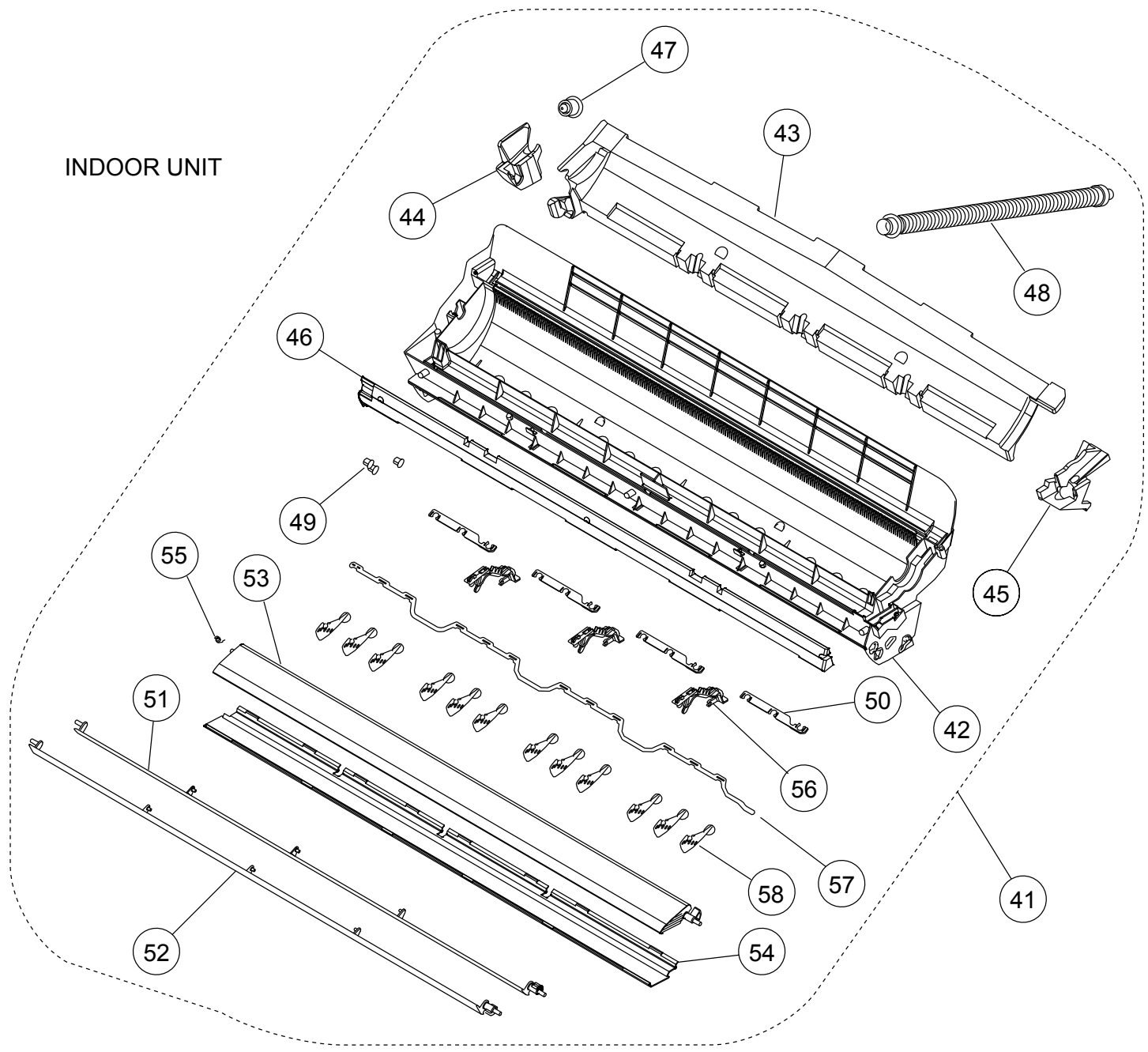

Ref	Description	Parts number
41	Casing Assy	9315331038
42	Casing	9314993015
43	Casing Cover B	9315016010
44	Casing Cover L	9315017017
45	Casing Cover R	9315018014
46	Casing Cover F	9315019011
47	Drain Cap	9367677009
48	Drain Hose Assy	9315769015
49	Bush B	9312156016
50	Spacer B	9312441013

Ref	Description	Parts number
51	Louver U	9315000019
52	Louver Z	9315001016
53	Diffuser U	9315002013
54	Diffuser Z	9315003010
55	Spring C	9314142017
56	Piller A	9315009012
57	Joint B	9315006011
58	R and L Louver	9311997016
-	Fan Guard	9305751051
-	Fan Guard Holder Right	9315814012
-	Fan Guard Holder Left	9315815019

# INDOOR UNIT

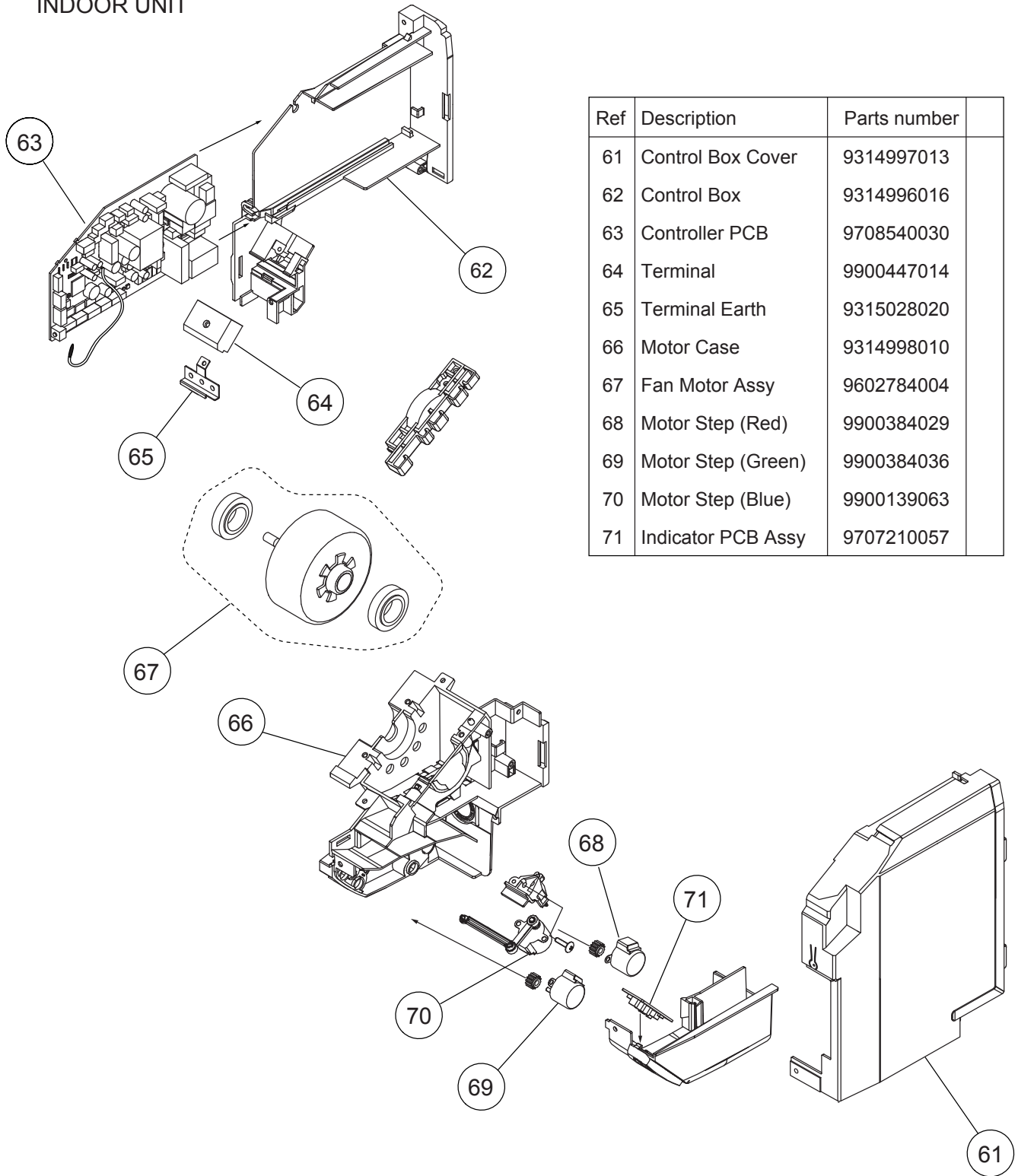

Ref	Description	Parts number
61	Control Box Cover	9314997013
62	Control Box	9314996016
63	Controller PCB	9708540030
64	Terminal	9900447014
65	Terminal Earth	9315028020
66	Motor Case	9314998010
67	Fan Motor Assy	9602784004
68	Motor Step (Red)	9900384029
69	Motor Step (Green)	9900384036
70	Motor Step (Blue)	9900139063
71	Indicator PCB Assy	9707210057

# PARTS

## OUTDOOR UNIT

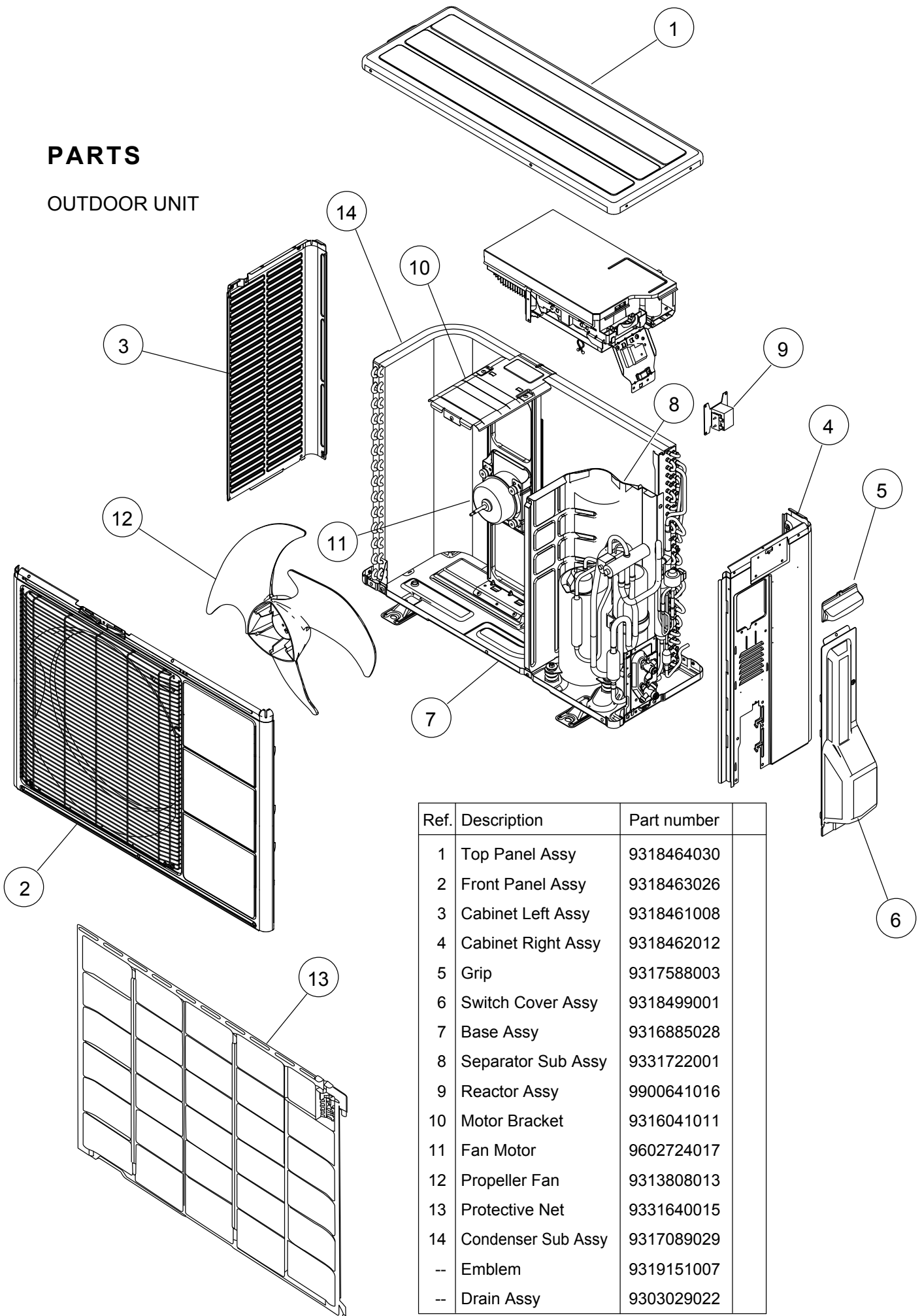

Ref.	Description	Part number
1	Top Panel Assy	9318464030
2	Front Panel Assy	9318463026
3	Cabinet Left Assy	9318461008
4	Cabinet Right Assy	9318462012
5	Grip	9317588003
6	Switch Cover Assy	9318499001
7	Base Assy	9316885028
8	Separator Sub Assy	9331722001
9	Reactor Assy	9900641016
10	Motor Bracket	9316041011
11	Fan Motor	9602724017
12	Propeller Fan	9313808013
13	Protective Net	9331640015
14	Condenser Sub Assy	9317089029
--	Emblem	9319151007
--	Drain Assy	9303029022



# OUTDOOR UNIT

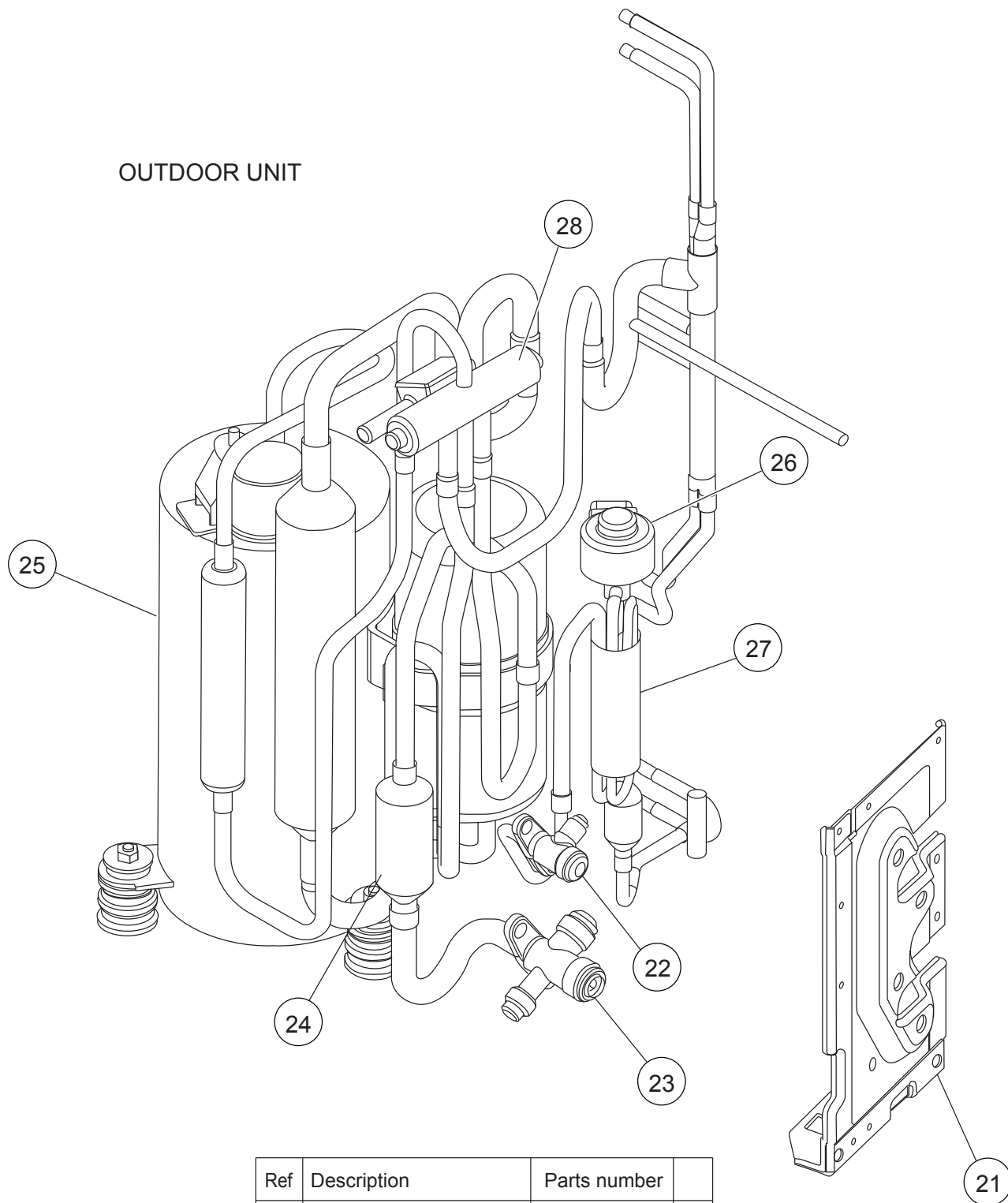

Ref	Description	Parts number
21	Bracket Valve	9331649001
22	2-way Valve Assy	9314554018
23	3-way Valve Assy	9316388017
24	Muffler	9316276017
25	Compressor Assy	9313279011
26	Expansion Valve Coil	9970095030
27	Pulse Motor Valve Assy	9314557019
28	4-way Valve Assy	9315311047
--	Solenoid	9970055010



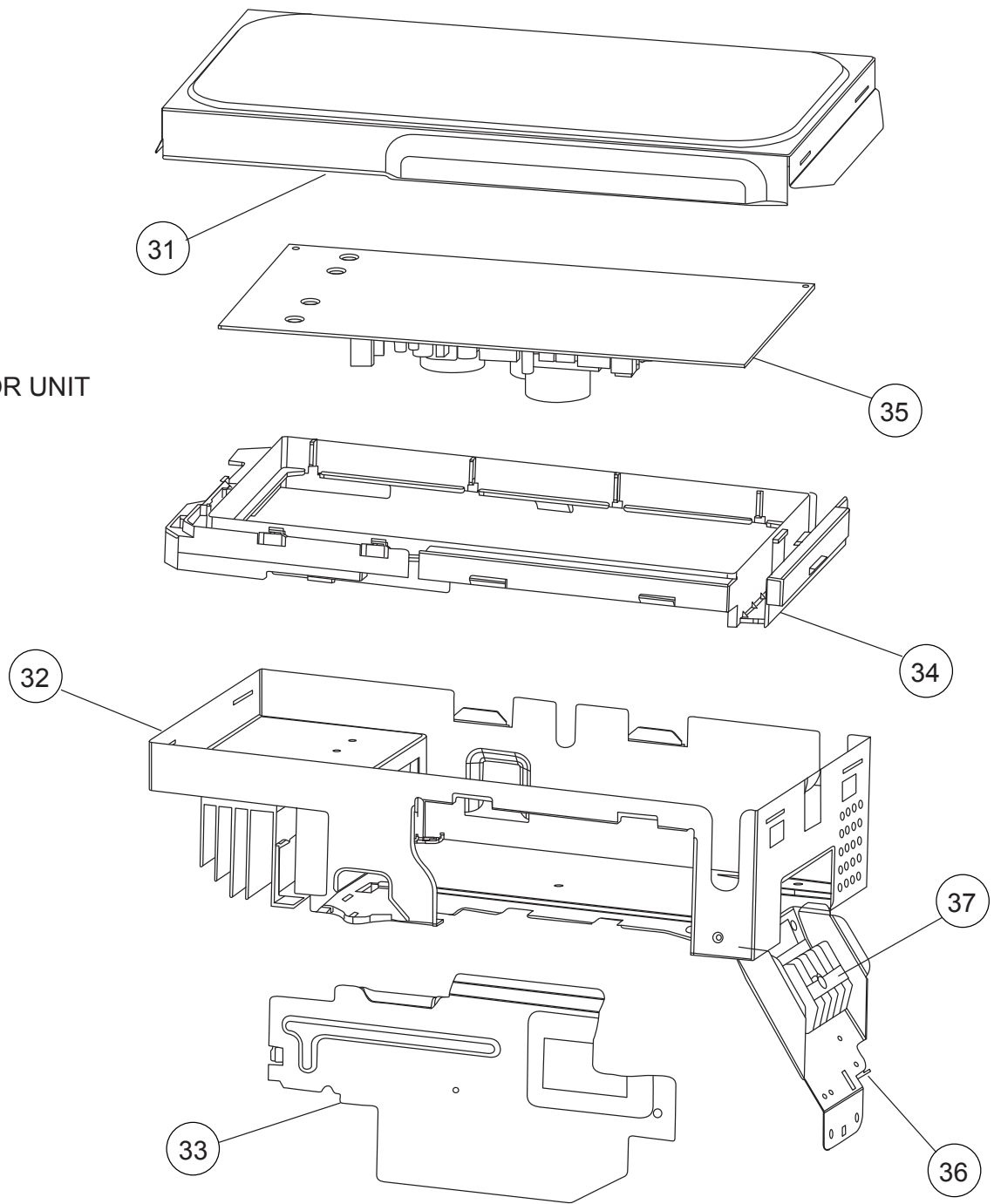



OUTDOOR UNIT

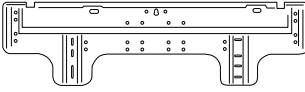
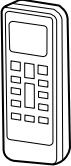

Ref	Description	Parts number
31	Sealed Panel	9309913011
32	Inverter Case Assy	9315690029
33	Inverter Case Cover	9314507038
34	PCB Holder	9313074029
35	PCB Assy	9708753089
36	Bracket Terminal	9315233080
37	Terminal	9900421038
--	Thermistor Assy	9900148041
--	Outdoor Thermistor	9900544010

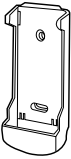
# ACCESSORIES

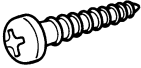
## INDOOR UNIT

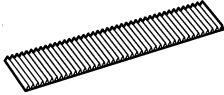
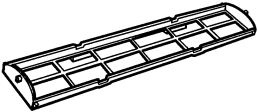
Name and Shape	Q'ty
Wall hook bracket 	1
Remote control 	1
Battery 	2
Remote control holder 	1
Drain hose insulation 	1
Cloth tape 	1
Tapping screw (big) 	8
Tapping screw (small) 	2
Air cleaning filter 	2
Air cleaning filter frame 	2

1101G3874

---