

**SPLIT TYPE ROOM AIR
CONDITIONER**

WALL MOUNTED type

SERVICE MANUAL

Models

Indoor unit

Outdoor unit

ASY9FSBCW

AOY9FSBC

ASY12FSBCW

AOY12FSBC



CONTENTS

SPECIFICATIONS	1
OUTLINE AND DIMENSIONS	3
REFRIGERANT SYSTEM DIAGRAM	4
CIRCUIT DIAGRAM.....	5
INDOOR PRINTED CIRCUIT BOARD CIRCUIT DIAGRAM	6
ERROR DISPLAY	7
DISASSEMBLY ILLUSTRATION	9
PARTS LIST.....	13
STANDARD ACCESSORIES	15

FUJITSU GENERAL LIMITED

SPECIFICATIONS

TYPE	COOLING	COOLING
INDOOR UNIT	ASY9FSBCW	ASY12FSBCW
OUTDOOR UNIT	AOY9FSBC	AOY12FSBC
COOLING CAPACITY (kW)	2.75	3.40

ELECTRICAL DATA

POWER SOURCE	230V 50Hz	230V 50Hz
RUNNING CURRENT (A)	4.7	6.2
INPUT WATTS (kW)	1.05	1.33
E.E.R (kW/kW)	2.62	2.56
MOISTURE REMOVAL	1.3	1.8
AIR CIRCULATION-Hi (m ³ /hr)	540	540

COMPRESSOR

TYPE	Hermetic type, Permanent split condenser, 2 pole, Single phase, Induction motor	
POWER SOURCE	220, 230, 240V / 50Hz	220-240V / 50Hz
DISCRIMINATION	80230135	80235035
REFRIGERANT R410A (g)	590	720

FAN MOTOR

POWER SUPPLY (V)	230	230	
INDOOR UNIT	Hi-SPEED (r.p.m)	1,310	1,310
	MED-SPEED (r.p.m)	1,190	1,230
	LO-SPEED (r.p.m)	1,070	1,150
	S-LO (r.p.m)	960	1,080
OUTDOOR UNIT (r.p.m)	740	740	

DIMENSIONS

INDOOR UNIT	H x W x D (mm)	257 x 808 x 187	257 x 808 x 187
OUTDOOR UNIT		535 x 695 x 250	535 x 695 x 250

WEIGHT

INDOOR UNIT	GROSS	10 / 8	10 / 8
OUTDOOR UNIT	NET(kg)	33 / 30	35 / 32

NOISE LEVEL

INDOOR UNIT	Hi-SPEED (dB)	COOL 39	COOL 39
	MED-SPEED (dB)	COOL 37	COOL 37
	LO-SPEED (dB)	COOL 34	COOL 35
	S-LO (dB)	COOL 31	COOL 33
OUTDOOR UNIT	(dB)	COOL 45	COOL 46

ADDITIONAL CHARGE OF REFRIGERANT
(ASY9FSBCW / AOY9FSBC)
(ASY12FSBCW / AOY12FSBC)

Refrigerant suitable for a piping length of 7.5 m is charged in the outdoor unit at the factory.

When the piping is longer than 7.5 m, additional charging is necessary.

For the additional amount, see the table below.

PIPE LENGTH	7.5 m	10 m	15 m
ADDITIONAL REFRIGERANT	None	50 g	150 g

Between 7.5 m and 10 m, when using a connection pipe other than that in the table, charge additional refrigerant with 20g /1 m as the criteria.

(The maximum length of piping is 15m. If the units are further apart than this, correct operation can not be guaranteed.)

DIMENSIONS

INDOOR UNIT

Unit : mm

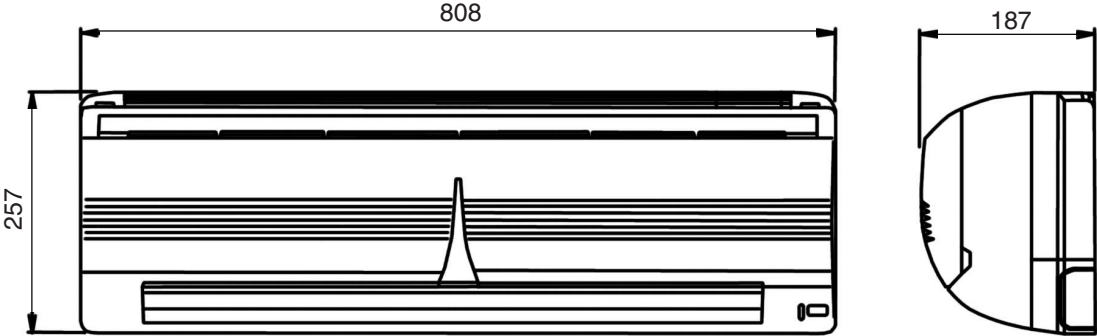

OUTDOOR UNIT

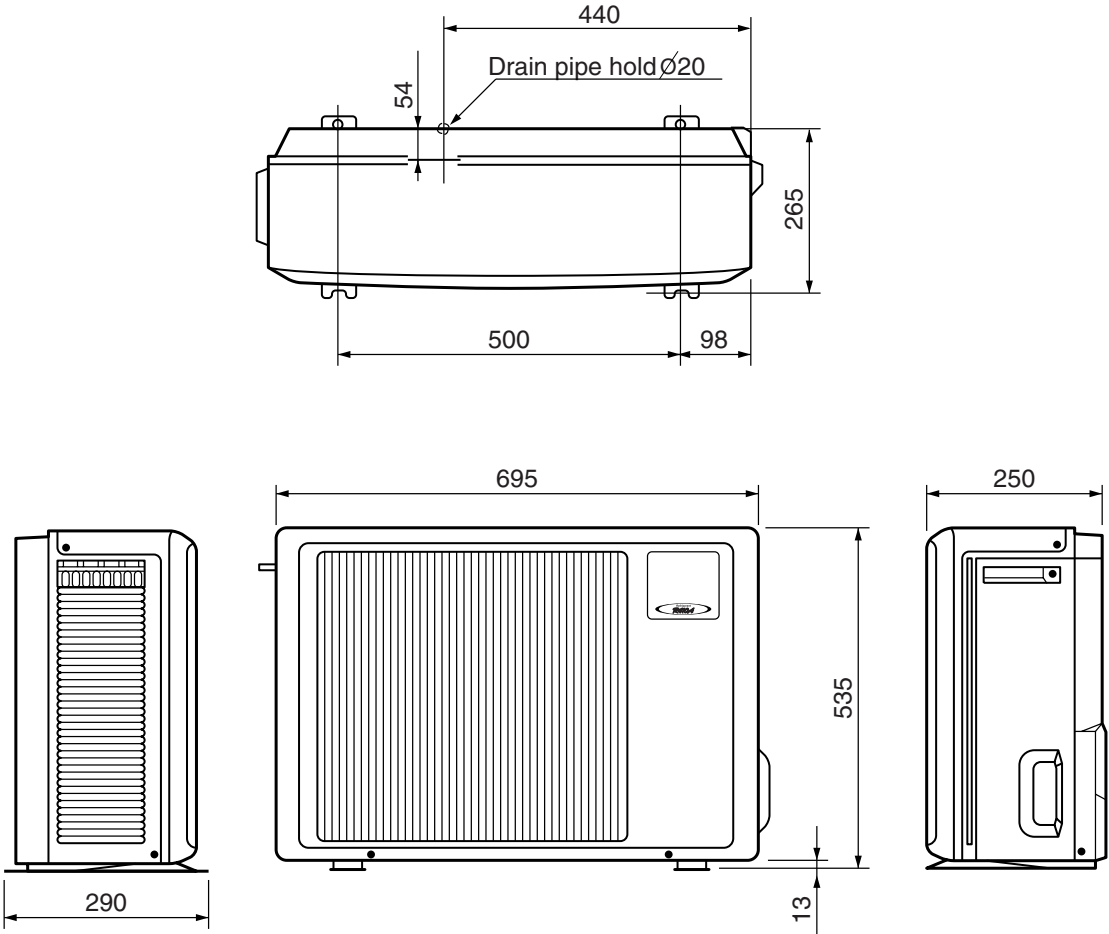

REFRIGERANT SYSTEM DIAGRAM

Models : ASY9FSBCW / AOY9FSBC

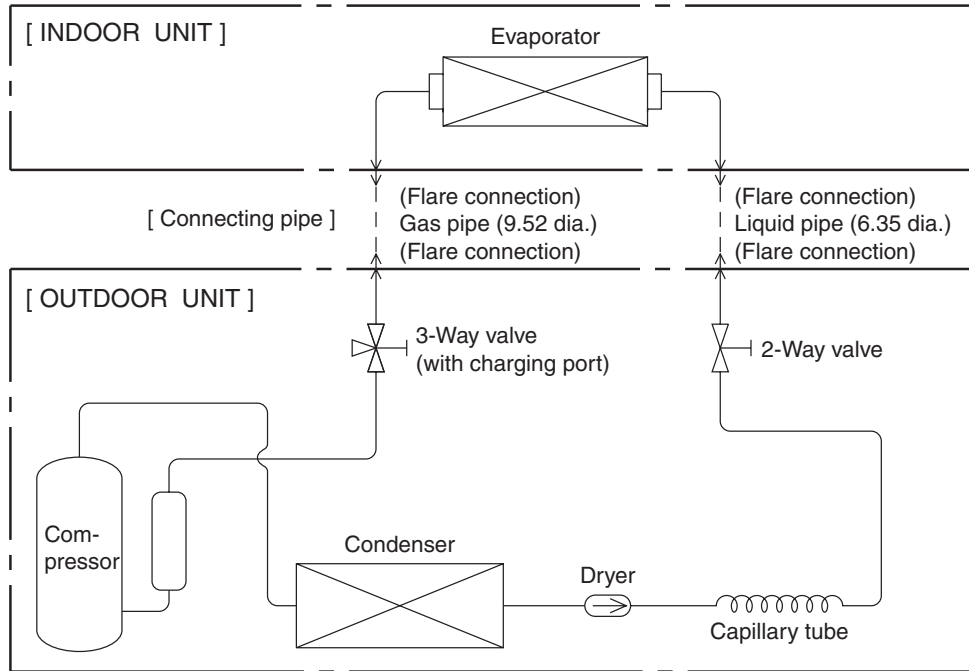

Models : ASY12FSBCW / AOY12FSBC

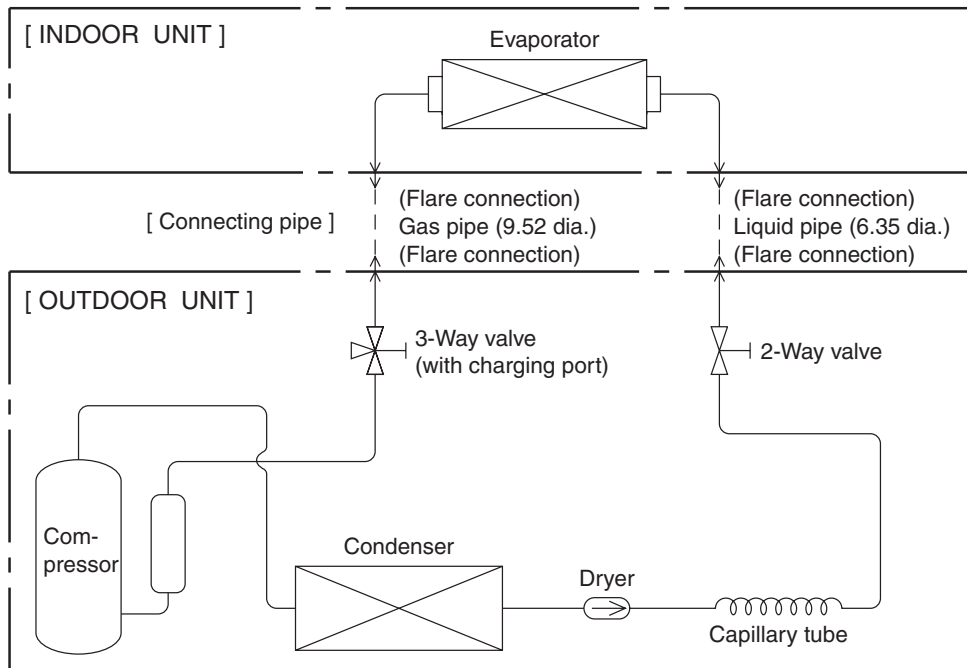

CIRCUIT DIAGRAM

Models : ASY9FSB CW / A OY9FSB C
 ASY12FSB CW / A OY12FSB C

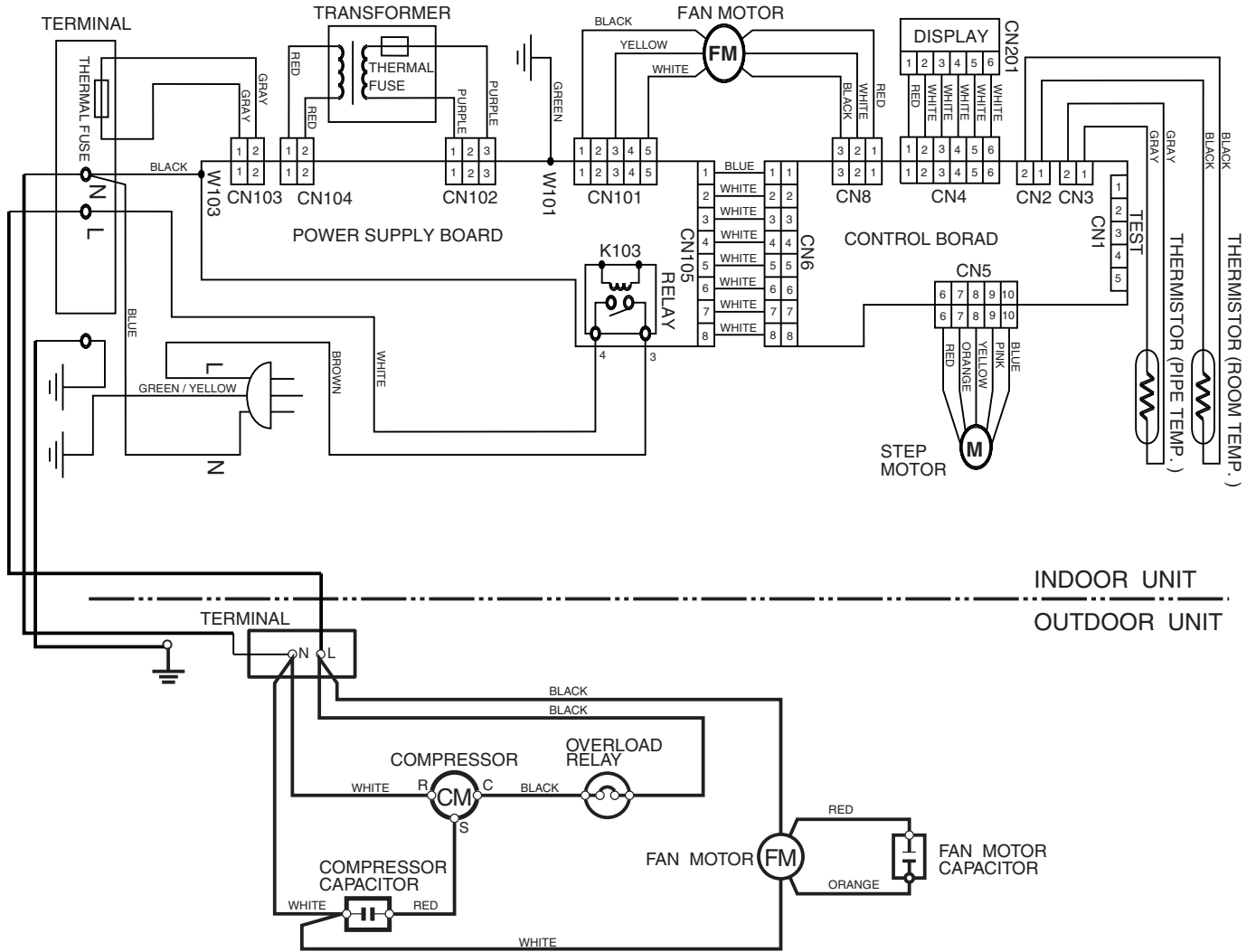

Models : ASY9FSBCW
ASY12FSBCW

INDOOR PRINTED CIRCUIT BOARD CIRCUIT DIAGRAM

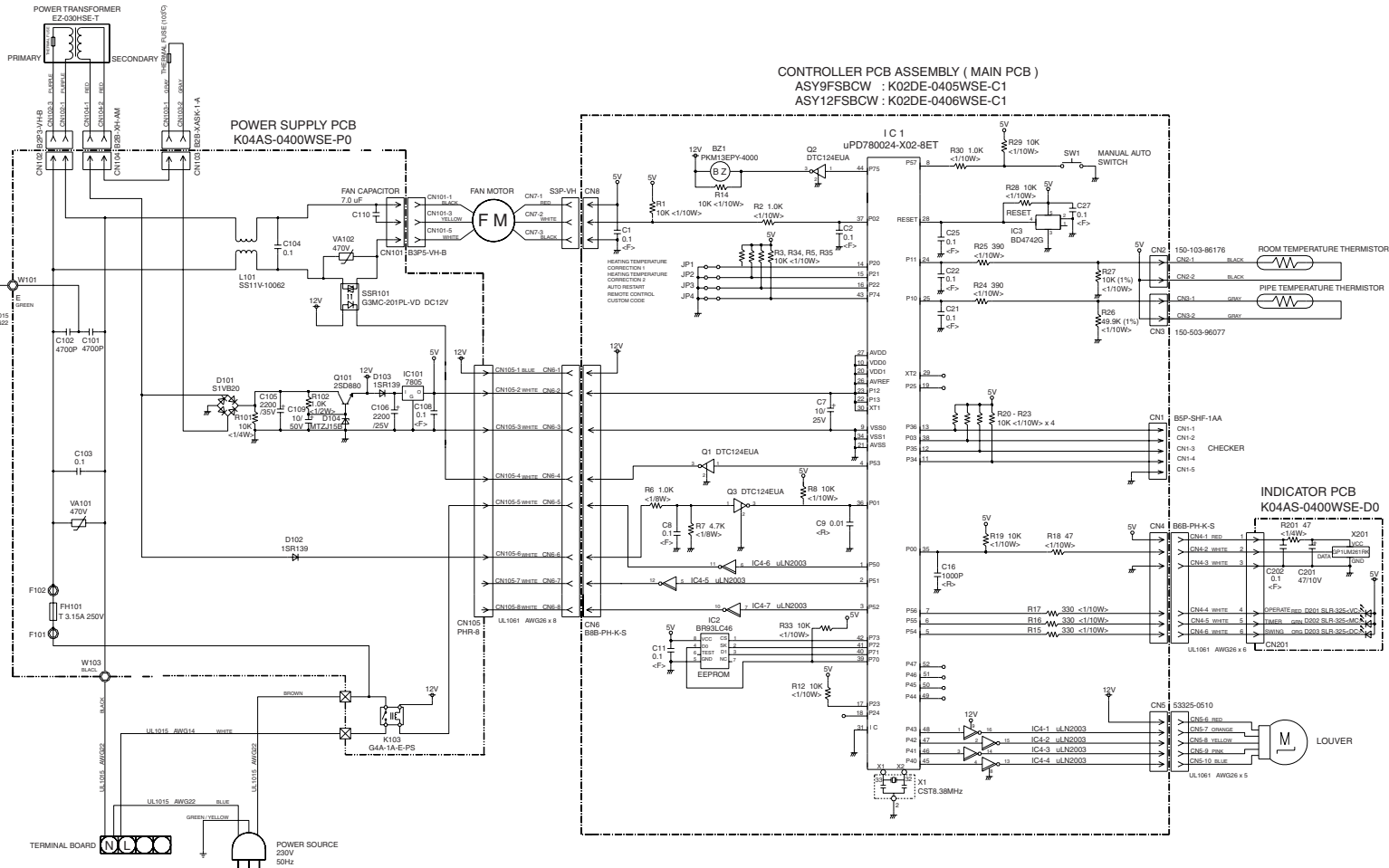

ERROR DISPLAY

Troubleshooting check table

Operation lamp : Red lamp
 Timer lamp : Green lamp

Large division indication			Small division indication		
Error contents	LED indication		Error contents	LED indication	
thermistor error	RED lamp	● (2 times)	thermistor error (room temp.)	RED lamp	○
	Green lamp	○		Green lamp	● (2 times)
control unit error (indoor unit)	RED lamp	● (4 times)	thermistor error (heat exchanger)	RED lamp	○
	Green lamp	○		Green lamp	● (3 times)
fan motor error (indoor unit)	RED lamp	● (6 times)	MANUAL AUTO button error	RED lamp	○
	Green lamp	○		Green lamp	● (2 times)
			power source Hz decision error	RED lamp	○
				Green lamp	● (4 times)
			lock error	RED lamp	○
				Green lamp	● (2 times)
			rpm error	RED lamp	○
				Green lamp	● (3 times)

● : 0.5s ON/OFF repeated
 ○ : 0.1s ON/OFF repeated

Thermistor resistance values <Indoor unit side> ASY9FSB, ASY12FSB

1) Room temperature thermistor (TH_A)

Room temperature (°C)	0	2.5	5	7.5	10	12.5	15	17.5	20	22.5	25	27.5	30
Resistance value (kΩ)	33.6	29.5	25.9	22.8	20.2	17.9	15.8	14.1	12.5	11.2	10.0	9.0	8.0

Room temperature (°C)	32.5	35	37.5	40	42.5	45	47.5	50
Resistance value (kΩ)	7.2	6.5	5.9	5.3	4.8	4.3	3.9	3.6

2) Indoor heat exchanger temperature thermistor (TH_{HM}, TH_{HI})

Heat exchanger temperature (°C)	0	2.5	5	7.5	10	12.5	15	17.5	20	22.5	25	27.5	30
Resistance value (kΩ)	176.0	153.5	134.2	117.6	103.3	91.0	80.3	71.0	62.9	55.9	49.7	44.3	39.6

Heat exchanger temperature (°C)	32.5	35	37.5	40	42.5	45	47.5	50	52.5	55	57.5	60
Resistance value (kΩ)	35.4	31.7	28.5	25.6	23.1	20.8	18.8	17.1	15.5	14.1	12.8	11.6

DISASSEMBLY ILLUSTRATION

Model : ASY9FSBCW
ASY12FSBCW

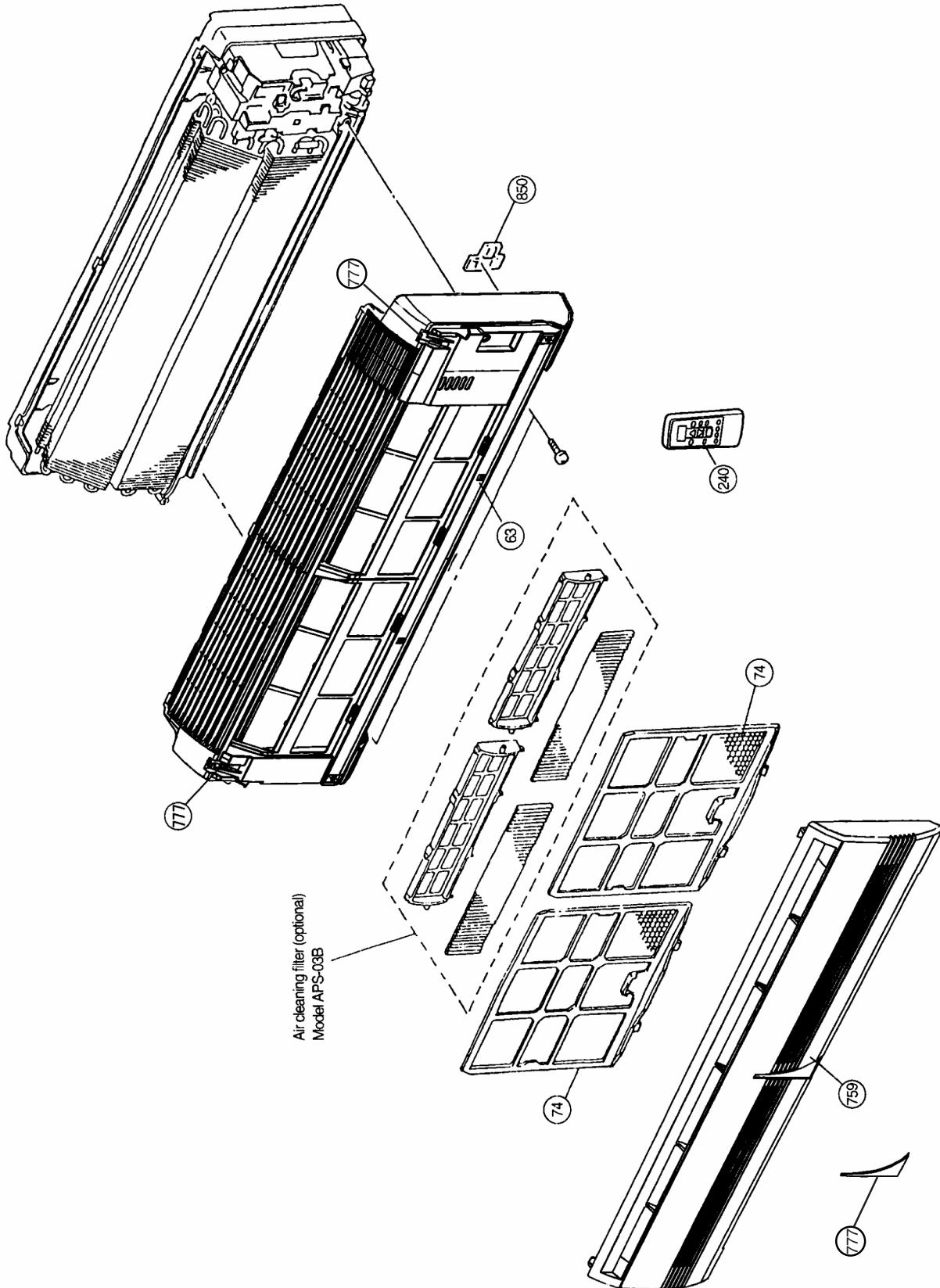

Models : ASY9FSBCW
ASY12FSBCW

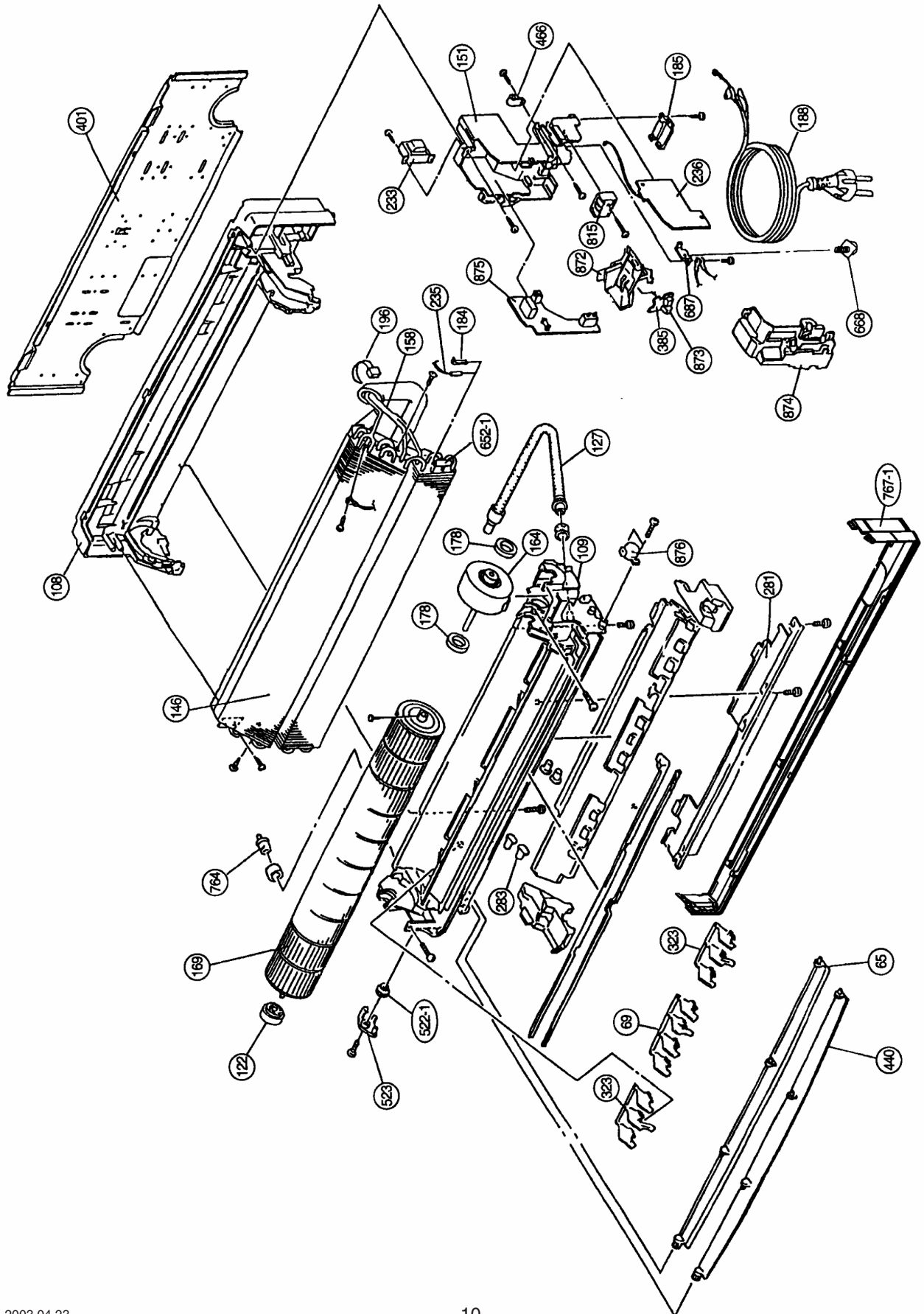

Model : AOY9FSBC

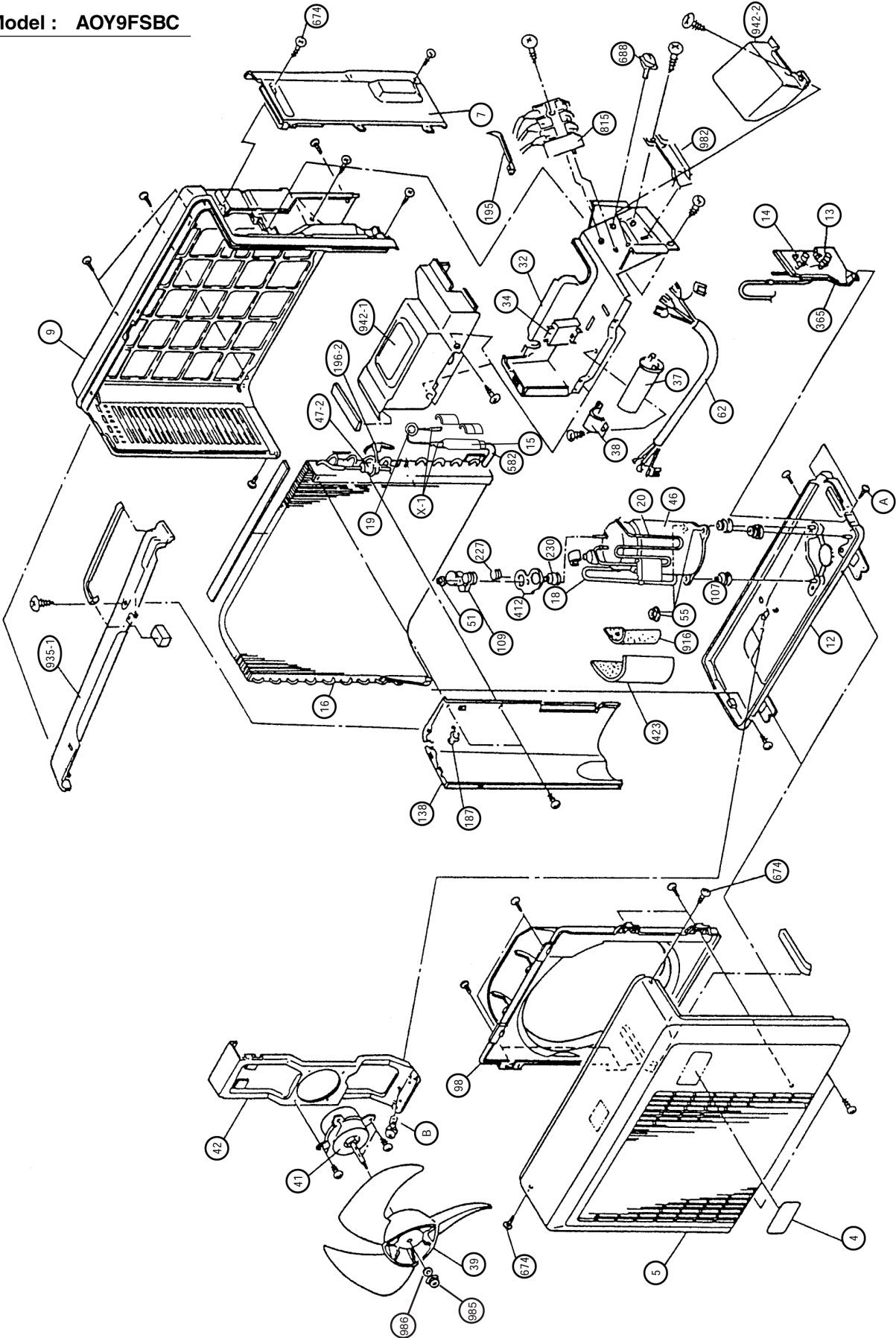

Model : AOY12FSBC

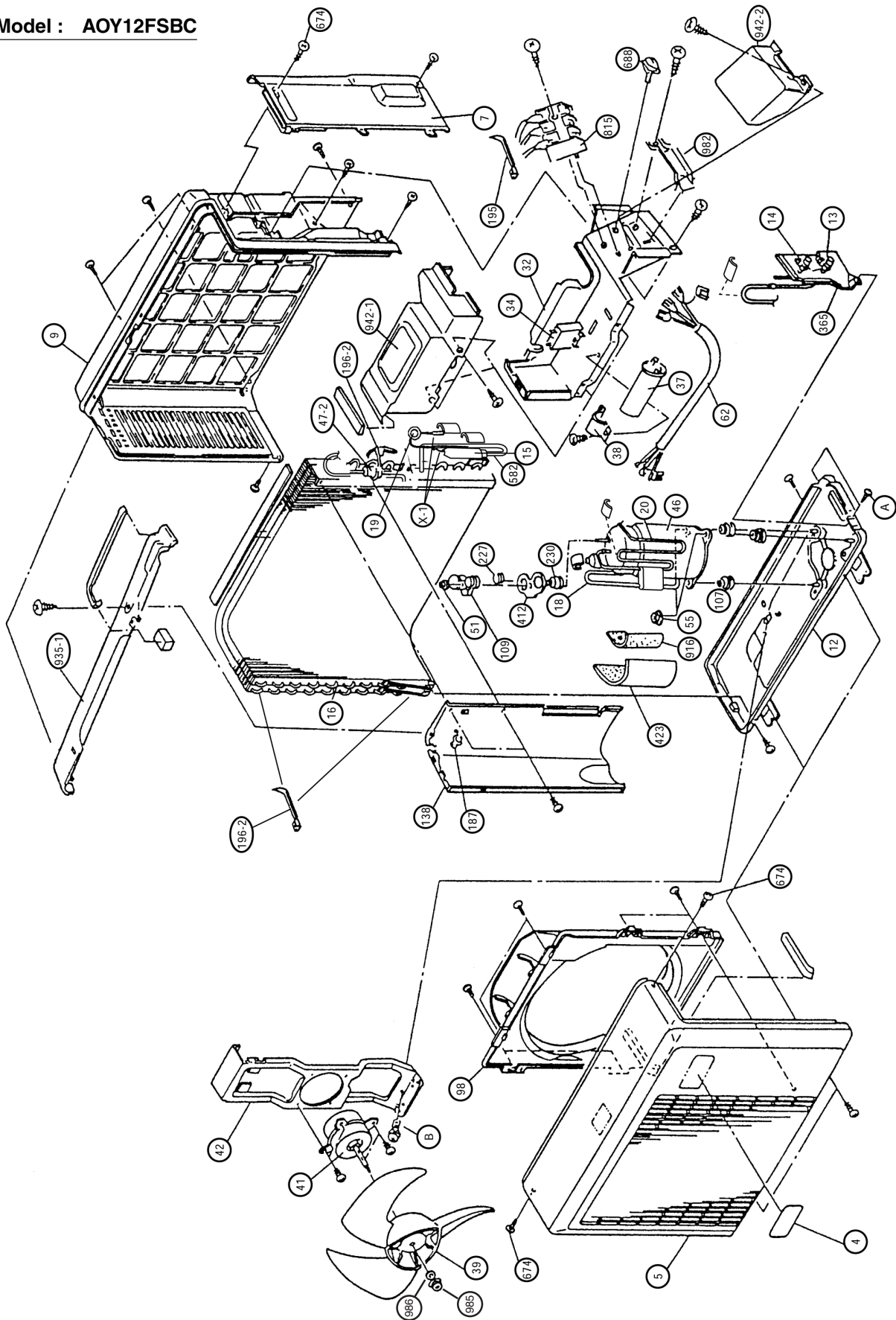

PARTS LIST

INDOOR UNIT

Ref. No.	Description	Part No.		Ord.
		ASY9FSBCW	ASY12FSBCW	Q'ty
63	Panel (Front) Total Assy	9312417032	9312417063	
65	Flow Control Panel-Z	9306058043	9306058043	
69	Louver-A	9306055028	9306055028	
74	Filter	9305444014	9305444014	
108	Base	9309755062	9309755062	
109	Casing	9306052027	9306052027	
122	Shaft Holder-B	9303066010	9303066010	
127	Drain Hose Assy	9305550029	9305550029	
146	Evaporator Assy	9330144019	9330144019	
151	Control Box	9330007017	9330007017	
158	Connecting Pipe Assy	9306416010	9306416010	
164	Fan Motor Assy-IN	9601172017	9601172017	
169	Cross-Flow Fan Assy	9307836015	9307836015	
178	Motor Cushion-M	9601302018	9601302018	
184	Thermistor Spring	313728262708	313728262708	
185	Wire Clamp	9330015012	9330015012	
188	Power Cord Assy	9702595043	9702595043	
196	Clamp SKB-150	313035356905	313035356905	
233	Power Transformer	9701803026	9701803026	
235	Thermistor Assy-Pipe	9702039059	9702039059	
236	Controller PCB Assy	9706046060	9706046077	
240	Remote Control Unit	9312058037	9312058037	
283	Bushing-A	9303529010	9303529010	
323	Louver-B	9306056025	9306056025	
385	Indicator PCB Assy	9706053013	9706053013	
401	Wall Hook Bracket	9304358008	9304358008	
440	Flow Control Panel-U	9306057046	9306057046	
466	Clamp NK-4N	313714328805	313714328805	
522-1	Gear-A	9306062002	9306062002	
523	Gear Bracket	9306407001	9306407001	
652-1	Thermistor Holder Pipe	313714262805	313714262805	
668	Screw w/Washer	313681304205	313681304205	
687	Earth Terminal	9330012011	9330012011	
759	Intake Grille-A	9330001015	9330001015	
764	Drain Cap Assy	9304150008	9304150008	
767-1	Bottom Cover-A	9330004016	9330004016	
777	Clamper (Grille)	9306755010	9306755010	
815	Terminal	9900040062	9900040062	
850	Window (Receiver)	9330003019	9330003019	
872	Indicator Case	9330009011	9330009011	
873	Lamp Cover	9330014015	9330014015	
874	Control Box Cover	9330008014	9330008014	
875	Power Supply PCB Assy	9706051019	9706051019	
876	Step Motor	9900139018	9900139018	
877	Face Panel (Front)-A	9330005044	9330005044	

OUTDOOR UNIT

Ref. No.	Description	Part No.		Ord.
		AOY9FSBC	AOY12FSBC	Qty
4	Emblem-Rear	9308468017	9308468017	
5	Cabinet Front Panel, Plastic	9306386016	9306386016	
7	Connector Cover (Cabinet)	9306119010	9306119010	
9	Cabinet Rear Panel, Plastic	9306385019	9306385019	
12	Base Assy, Painted	9306118020	9306118020	
13	3-Way Valve	9310085011	9310085011	
14	2-Way Valve	9310084014	9310084014	
15	Dryer	9312056002	9312056002	
16	Condenser Assy	9308463036	9308463036	
18	Suction Pipe	9308675002	9308679000	
19	Capillary Tube	9308670007	9308668004	
20	Discharge Pipe Assy	9308677006	9308681003	
32	Control Box Metal	9308561015	9308561015	
34	Capacitor (Fan Motor)	9900089023	9900089023	
37	Capacitor (Running)	9307588013	9307588013	
38	Clamp Metal (Capacitor)	313468061808	313468061808	
39	Propeller Fan	9305538003	9305538003	
41	Fan Motor Assy-Out	9307715013	9307715013	
42	Bracket (Motor)	9305536016	9305536030	
46	Compressor Assy	9310112014	9310110010	
47-2	Discharge Pipe Rubber	313185159802	313185159802	
51	Special Nut M5	313199233602	313199233602	
55	Special Nut M6	313252257701	313252257701	
62	Wire Assy (Shield)-A	9305695027	9305695027	
98	Fan Ring	9305581023	9305581023	
107	Rubber Seat-A	9351813017	9351813017	
109	Terminal Cover (Comp.)	9351120009	9351120009	
138	Separate Wall Metal	9305971008	9305971008	
187	Clamp No.1219	313361271706	313361271706	
195	Clamp SKB-100	313361275805	313361275805	
196-2	Clamp SKB-3MC	9305335008	9305335008	
230	Overload Relay	9308430007	9308445001	
365	Bracket (Valve)	9306748012	9306748012	
412	Terminal Gasket (Comp.)	9351121006	9351121006	
423	Noise Insulation-B	9308464019	9308464019	
582	Outlet Pipe (Cond.)	9312269006	9312270002	
674	Tapping Screw (Special)	9307303012	9307303012	
688	Screw (with Square Washer)	313681304205	313681304205	
815	Terminal-3P	9306489014	9306489014	
916	Noise Insulation-G	9306362003	9306362003	
935-1	Reinforcement(Cabinet Top)	9305973002	9305973002	
942-1	Control Box Cover-A Metal	9308562012	9308562012	
942-2	Control Box Cover-B Metal	9305975006	9305975006	
982	Cord Clamp (Plastic, Black)	9302271002	9302271002	
985	Special Nut w/Washer	9304902003	9304902003	
986	Special Washer	9304903000	9304903000	
A	Screw (serrated)	9356802009	9356802009	
B	Screw (with Spring Washer)	0700179013	0700179013	
X-1	Connection Pipe (Capillary)	9308667007	9308667007	
	BR Sheet 100x120x T5	9305039029	9305039029	
	BR Sheet 30x120x T7	-----	9305039036	
	BR Sheet 180x180x T2	9305039067	9305039067	
	BR Sheet 100x160x T5	9305039074	9305039074	
	BR Sheet 170x130x T2	9305498062	9305498062	
	BR Sheet 55 x 135x T2	9305039166	9305039166	





Note : Always use specified screws, since Ref No. 668, A and B are screws for the earth.

Ref No. 668 : Machine screw (with spring washer) M4 x P0.7 x L10, plating thickness 5 or more

A : Tapping screw (with inner clip washer) M4 x L10, plating thickness 5 or more

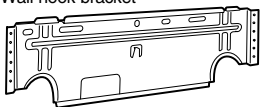
B : Machine screw (with spring washer) M4 x P0.7 x L10, plating thickness 5 or more

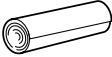
STANDARD ACCESSORIES

Name and Shape	Part No.
Wall hook bracket 	9304358008
Remote control unit 	9312094066
Battery (penlight) 	0600185534
Cloth tape 	9308117007
Tapping screw (4 x 25) 	0700076046

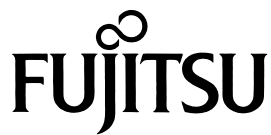

FUJITSU GENERAL LIMITED