

SPLIT TYPE  
ROOM AIR CONDITIONER  
WALL MOUNTED TYPE

# SERVICE MANUAL



Indoor unit	Outdoor unit
ASU18RLF	AOU18RLXFW
ASU24RLF	AOU24RLXFW

## CONTENTS

SPECIFICATIONS .....	1
DIMENSIONS .....	2
REFRIGERANT SYSTEM DIAGRAM .....	4
CIRCUIT DIAGRAM .....	5
INDOOR PCB CIRCUIT DIAGRAM .....	6
OUTDOOR PCB CIRCUIT DIAGRAM .....	9
ERROR DERECTION .....	15
PARTS (INDOOR UNIT) .....	16
PARTS (OUTDOOR UNIT) .....	20
ACCESSORIES .....	24

# SPECIFICATIONS

## ELECTRICAL DATA

TYPE		Cool & heat inverter	
INDOOR UNIT		ASU18RLF	ASU24RLF
OUTDOOR UNIT		AOU18RLXFW	AOU24RLXFW
COOLING CAPACITY		18,000 BTU/h 5.28 kW	22,000 BTU/h 6.50 kW
HEATING CAPACITY		21,600 BTU/h 6.30 kW	27,600 BTU/h 8.10 kW
POWER SOURCE		208 V / 230 V	208 V / 230 V
FREQUENCY		60 Hz	60 Hz
RUNNING CURRENT	Cooling	6.2 A	7.9 A
	Heating	8.0 A	10.5 A
INPUT WATTS	Cooling	1.35 kW	1.76 kW
	Heating	1.80 kW	2.38 kW
E.E.R.	Cooling	13.3 BTU/kW 3.90 kW/kW	12.5 BTU/kW 3.69 kW/kW
COP	Heating	12.0 BTU/kW 3.50 kW/kW	11.6 BTU/kW 3.40 kW/kW
MOISTURE REMOVAL		5.9 Pt/h 2.8 L/hr	6.3 Pt/h 3.0 L/hr
AIR CIRCULATION HIGH		541 cfm 920 m3/hr	659 cfm 1,120 m3/hr
MAXIMUM CURRENT		14.5 A	15.5 A

## FAN MOTOR

POWER SOURCE		230 V	230 V
INDOOR UNIT	High speed	1,260 r.p.m.	1,480 r.p.m.
	Middle speed	1,020 r.p.m.	1,220 r.p.m.
	Low speed	900 r.p.m.	1,020 r.p.m.
	Quiet	770 r.p.m.	900 r.p.m.
OUTDOOR UNIT	Cool	620 r.p.m.	800 r.p.m.
	Heat	620 r.p.m.	850 r.p.m.

## NOISE LEVEL

INDOOR UNIT	Cool 43 dB / Heat 44 dB	Cool 49 dB / Heat 49 dB
OUTDOOR UNIT	Cool 47 dB / Heat 50 dB	Cool 54 dB / Heat 55 dB

## COMPRESSOR AND REFRIGERANT

TYPE		Hermetic type, 6 pole, DC inverter motor, Rotary	
DISCRIMINATION		N-TF30ND1A	
WEIGHT WITH OIL		34.2 lb	15.5 kg
PRECHARGED REFRIGERANT		4 lb 10 oz	2,100 g
REFRIGERANT TYPE		R410A	
FULL CHARGE	Pipe length 66 ft 20 m	4 lb 10 oz	2,100 g
	164 ft 50 m	7 lb 4 oz	3,300 g
ADDITIONAL CHARGE		0.43 oz/ft	40 g/m

## DIMENSIONS

INDOOR UNIT	H x W x D	12-5/8 x 39-1/4 x 9 inch	320 x 998 x 228 mm
OUTDOOR UNIT	H x W x D	32-3/4 x 35-3/8 x 13 inch	830 x 900 x 330 mm

## WEIGHT

INDOOR UNIT	Shipping / Net	40 lbs / 31 lbs	18 kg / 14 kg
OUTDOOR UNIT	Shipping / Net	150 lbs / 135 lbs	68 kg / 61 kg

## DIMENSIONS

### INDOOR UNIT

Unit : inch (mm)

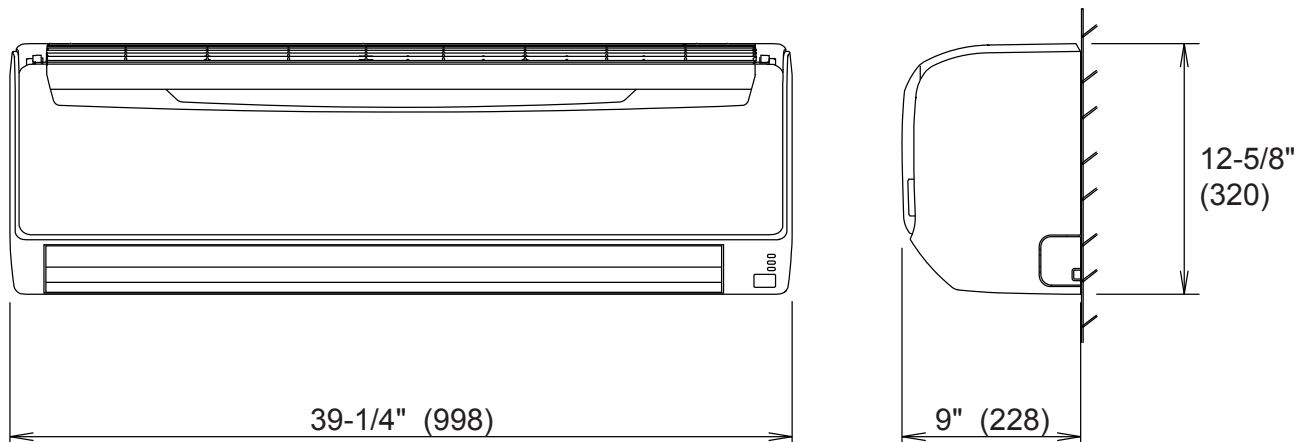

#### Drain pipe diameter

Inside : 5/8 inch (16 mm)

Outside : 1-3/32 inch (28 mm)

Liquid pipe diameter : 3/8 inch (9.52 mm)

Gas pipe diameter : 5/8 inch (15.88 mm)

# OUTDOOR UNIT

Unit : inch (mm)

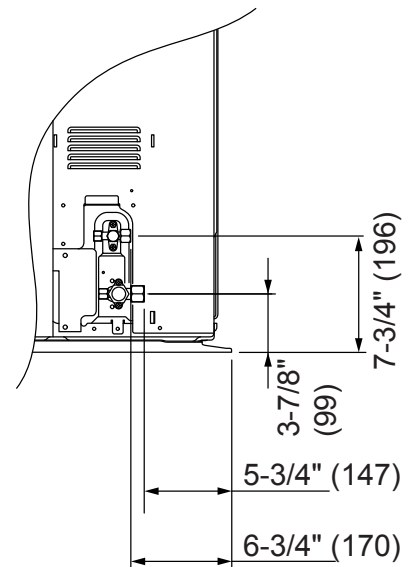
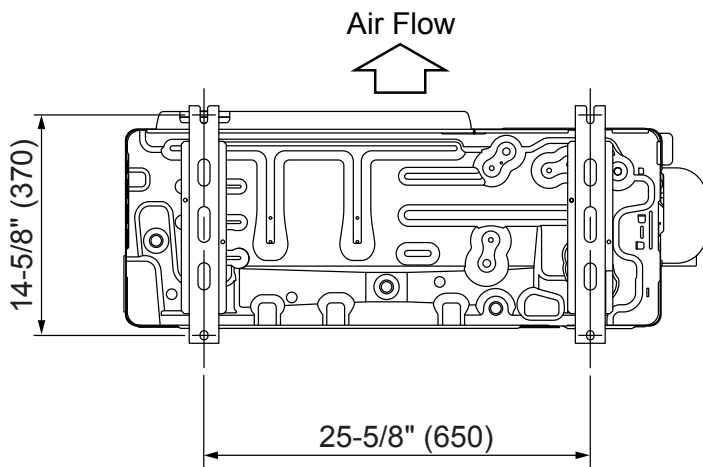
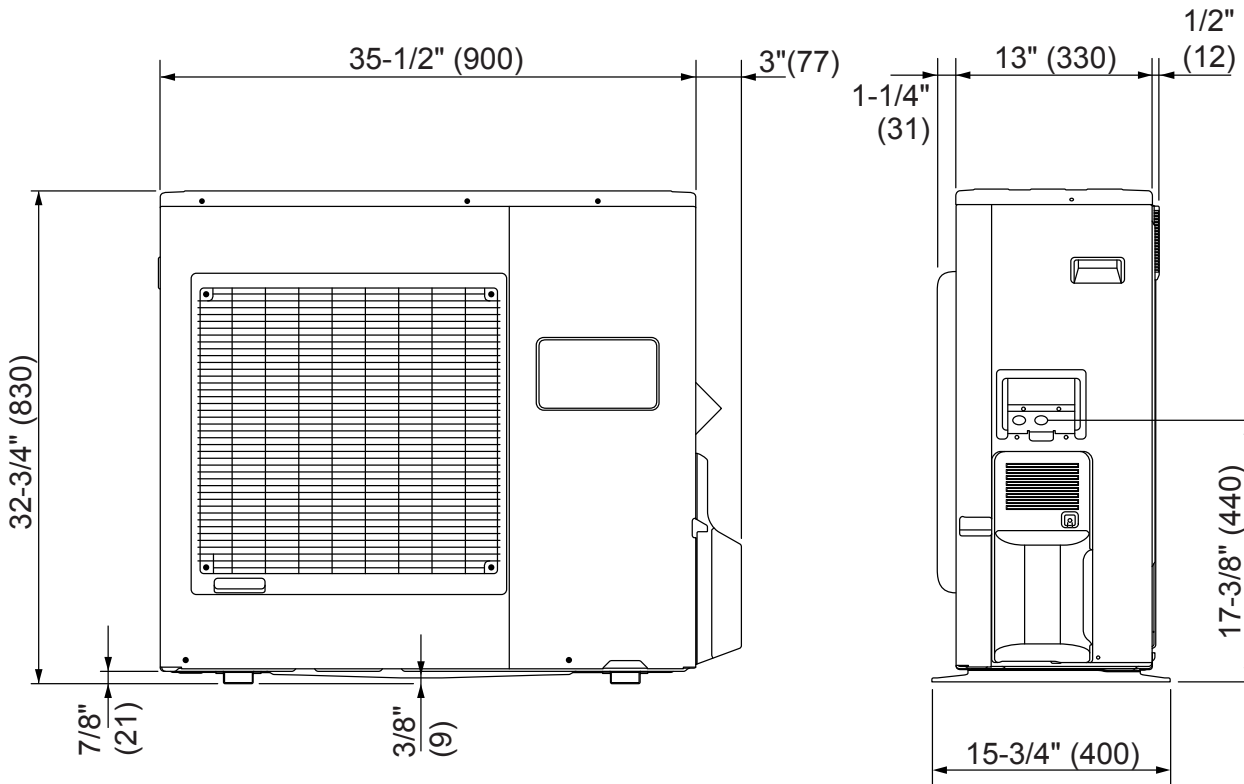
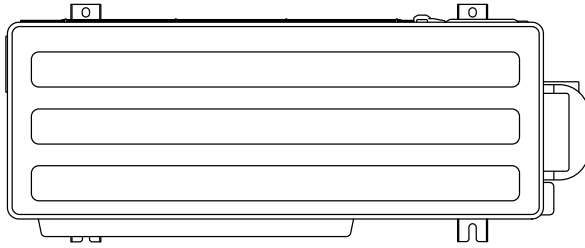

# REFRIGERANT SYSTEM DIAGRAM

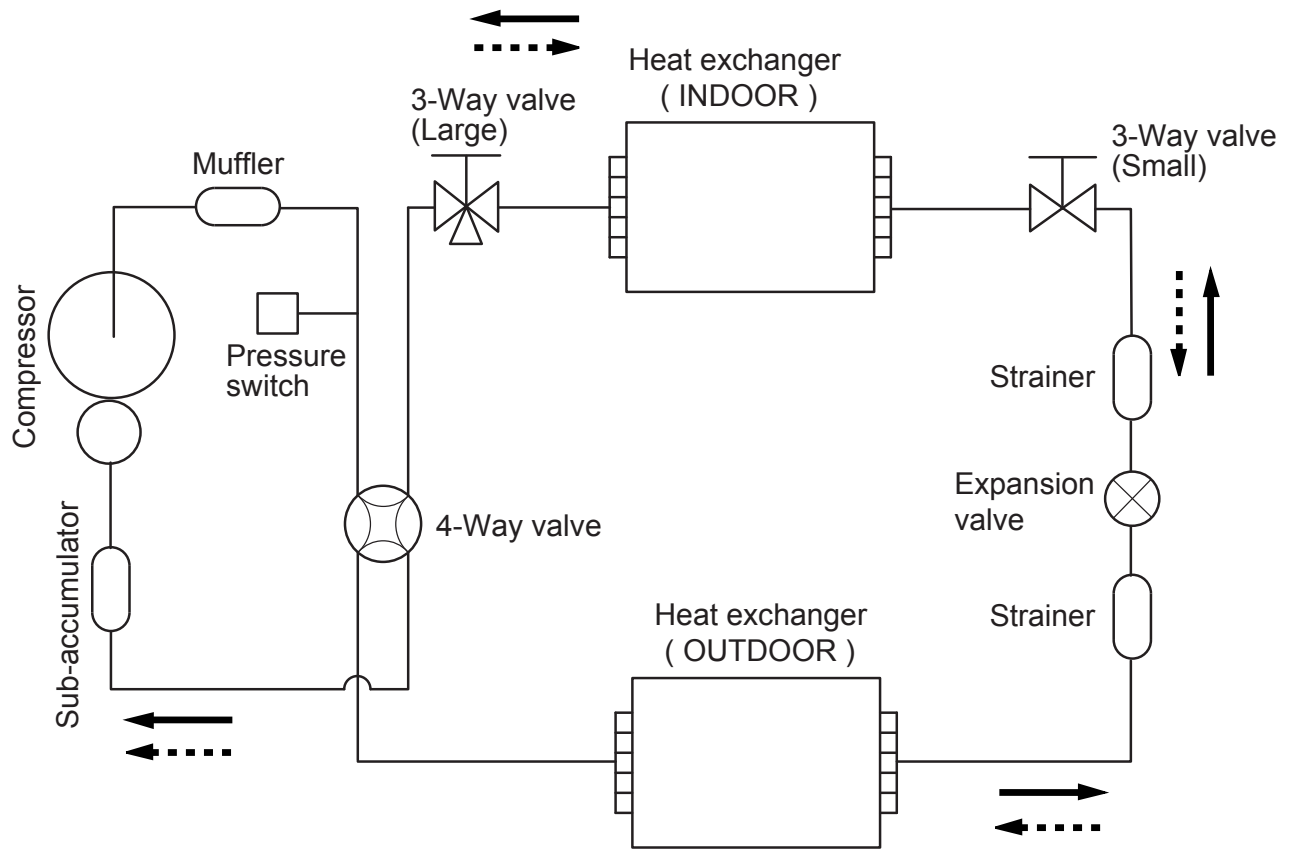

———→ Cooling flow  
 - - - -> Heating flow

Refrigerant pipe diameter  
 Liquid : 3/8" (9.52 mm)  
 Gas : 5/8" (15.88 mm)

# CIRCUIT DIAGRAM

## INDOOR UNIT

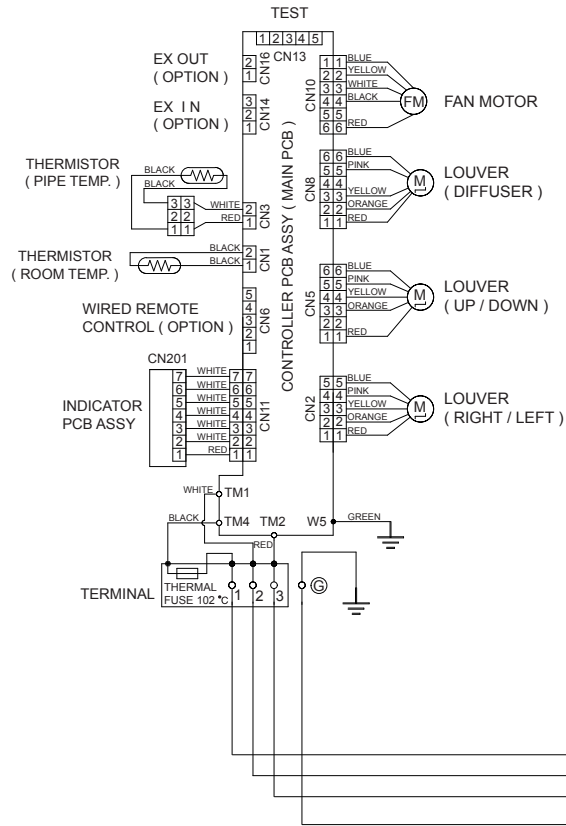

## OUTDOOR UNIT

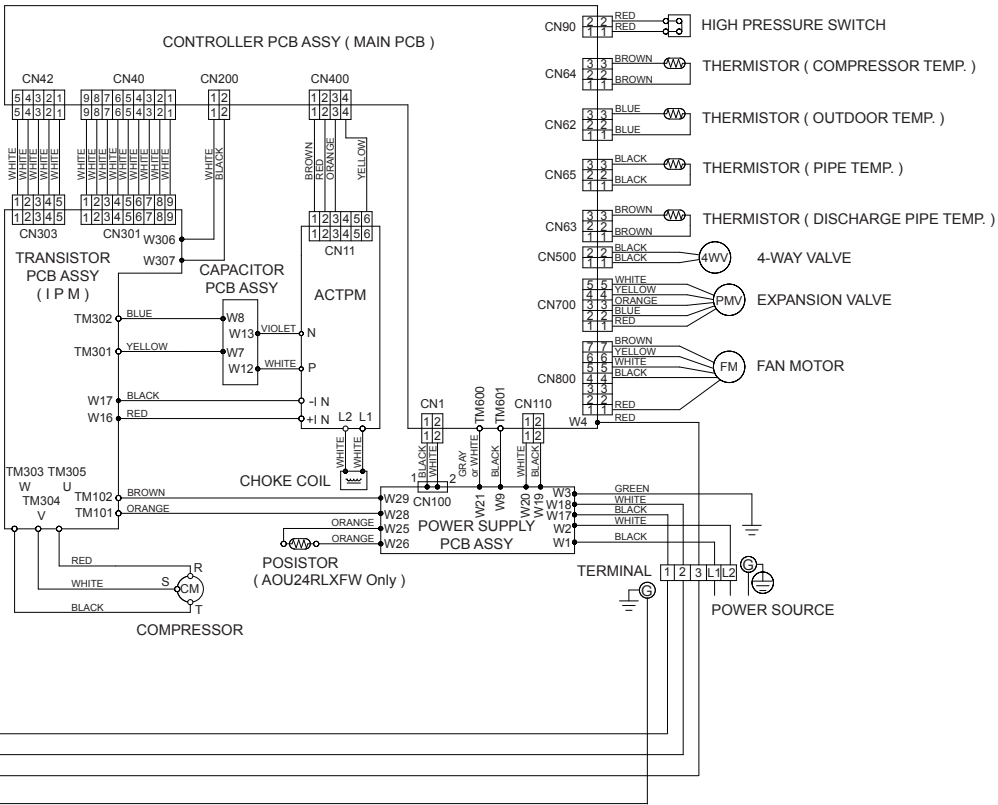

# INDOOR PCB CIRCUIT DIAGRAM

CONTROL UNIT  
ASU18RLF : EZ-0090DHSE  
ASU24RLF : EZ-0104HSE

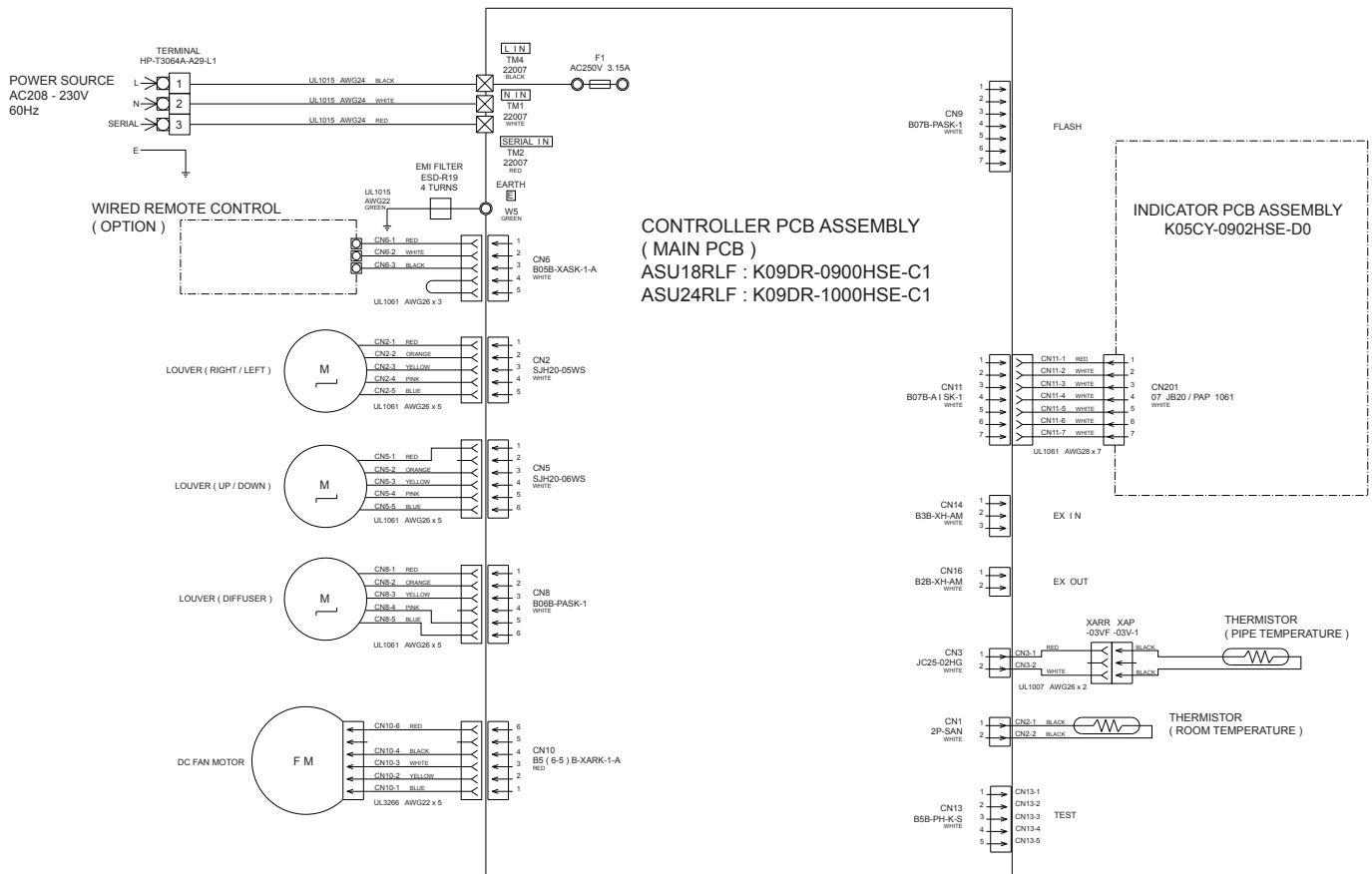

INDOOR UNIT  
 CONTROLLER PCB ASSEMBLY ( MAIN PCB )  
 ASU18RLF : K09DR-0900HSE-C1  
 ASU24RLF : K09DR-1000HSE-C1

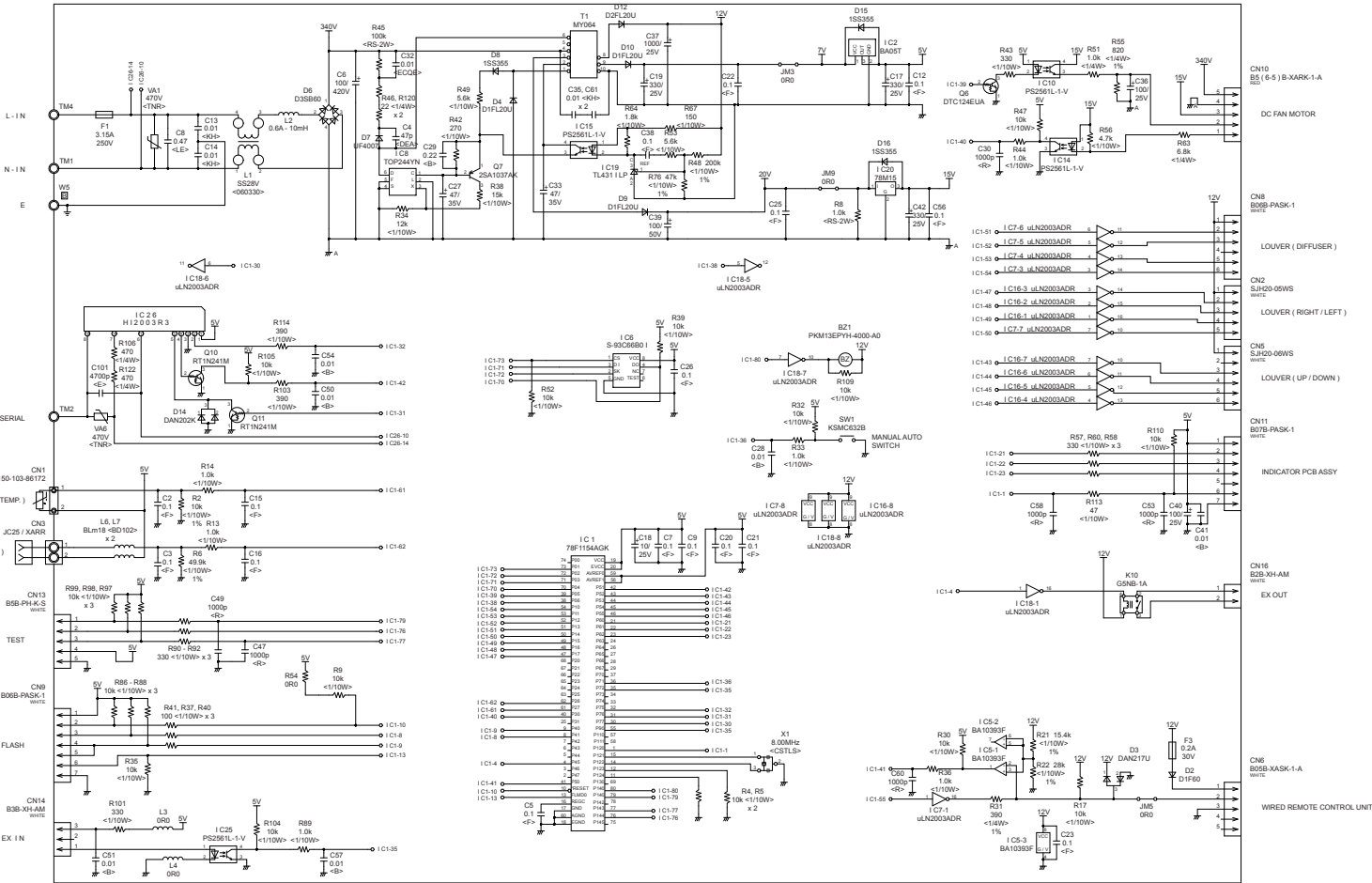



INDOOR UNIT  
 INDICATOR PCB ASSEMBLY  
 K05CY-0902HSE-D0

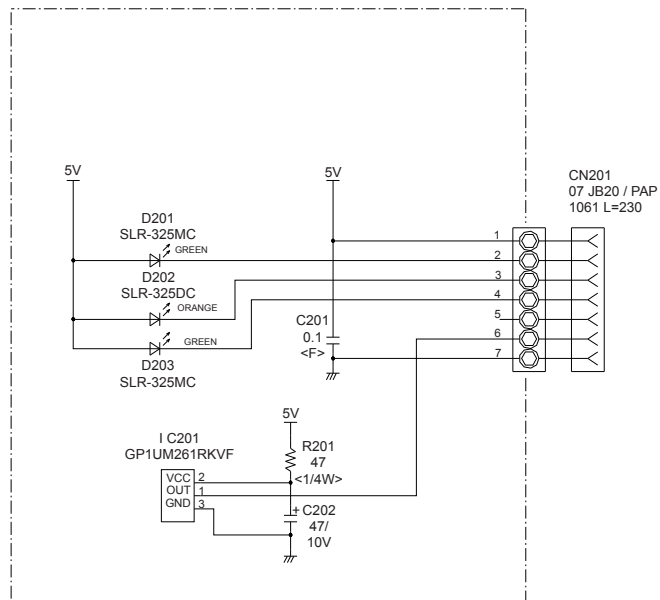

**OUTDOOR PCB  
CIRCUIT DIAGRAM**

INVERTER ASSEMBLY  
 AOU18RLXFW : EZ-01019HUE  
 AOU24RLXFW : EZ-0101AHUE

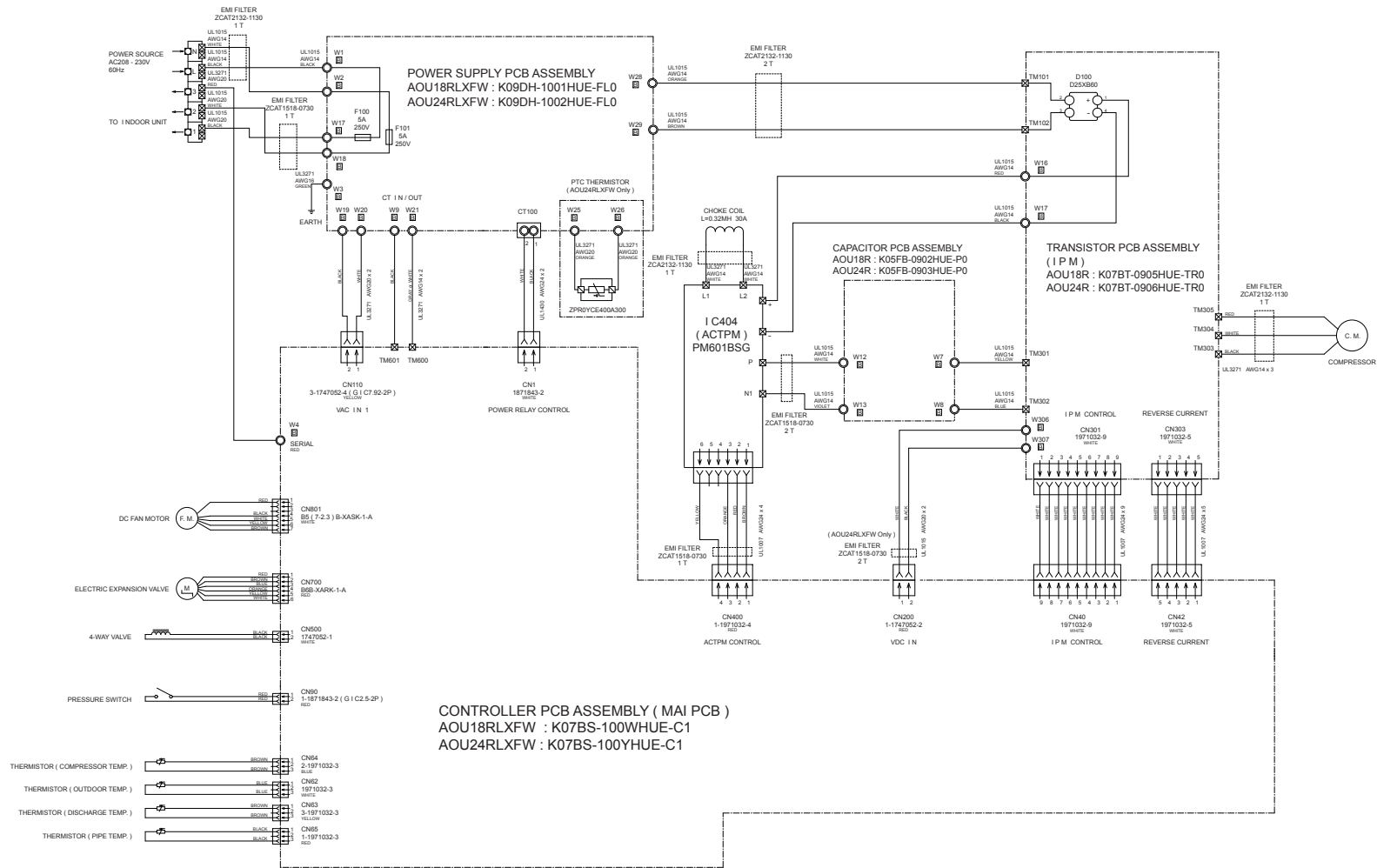

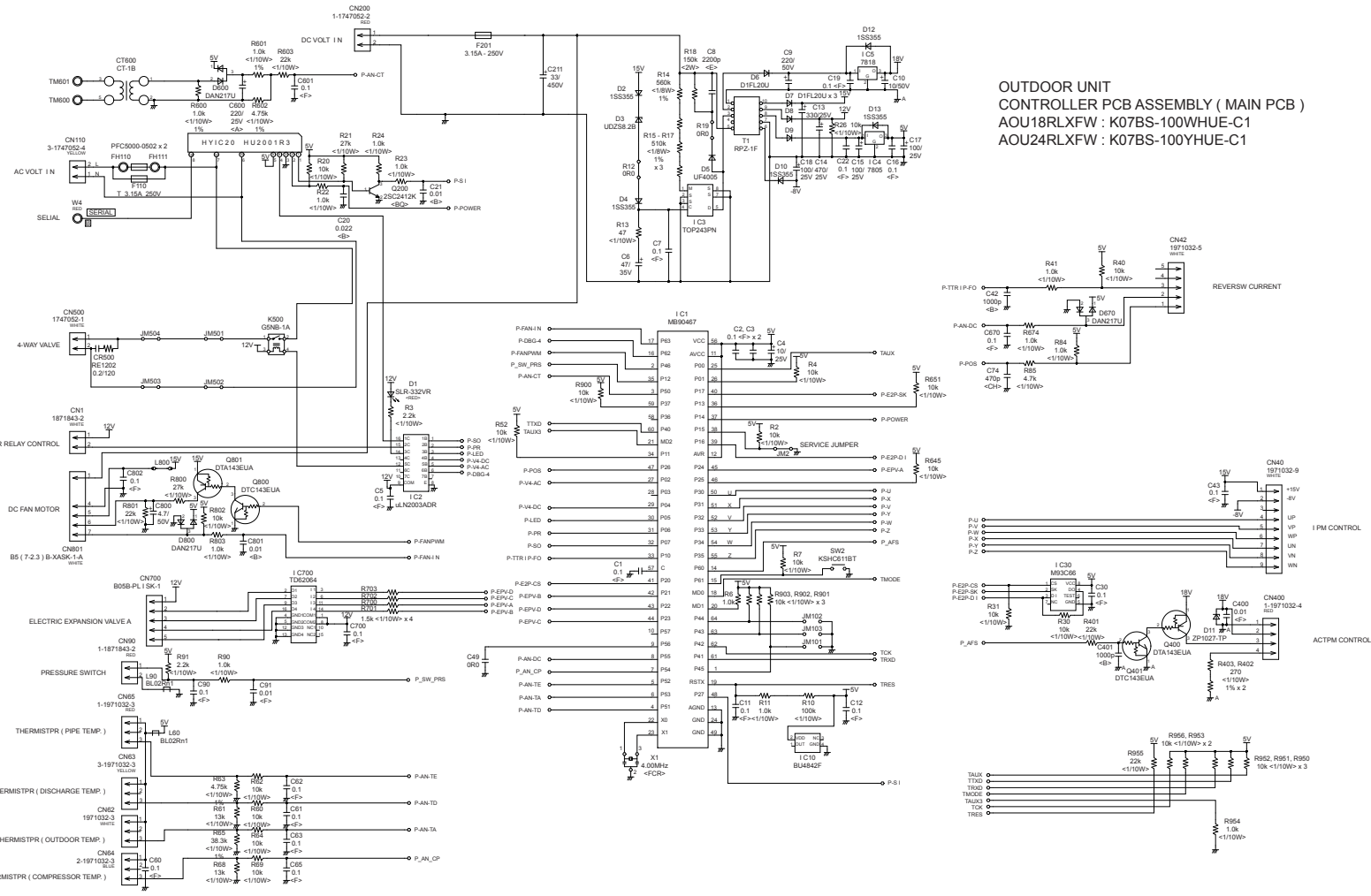

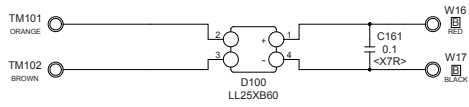

OUTDOOR UNIT  
 TRANSISTOR PCB ASSEMBLY ( I P M PCB )  
 AOU18RLXFW : K07BT-0905HUE-TR0  
 AOU24RLXFW : K07BT-0906HUE-TR0

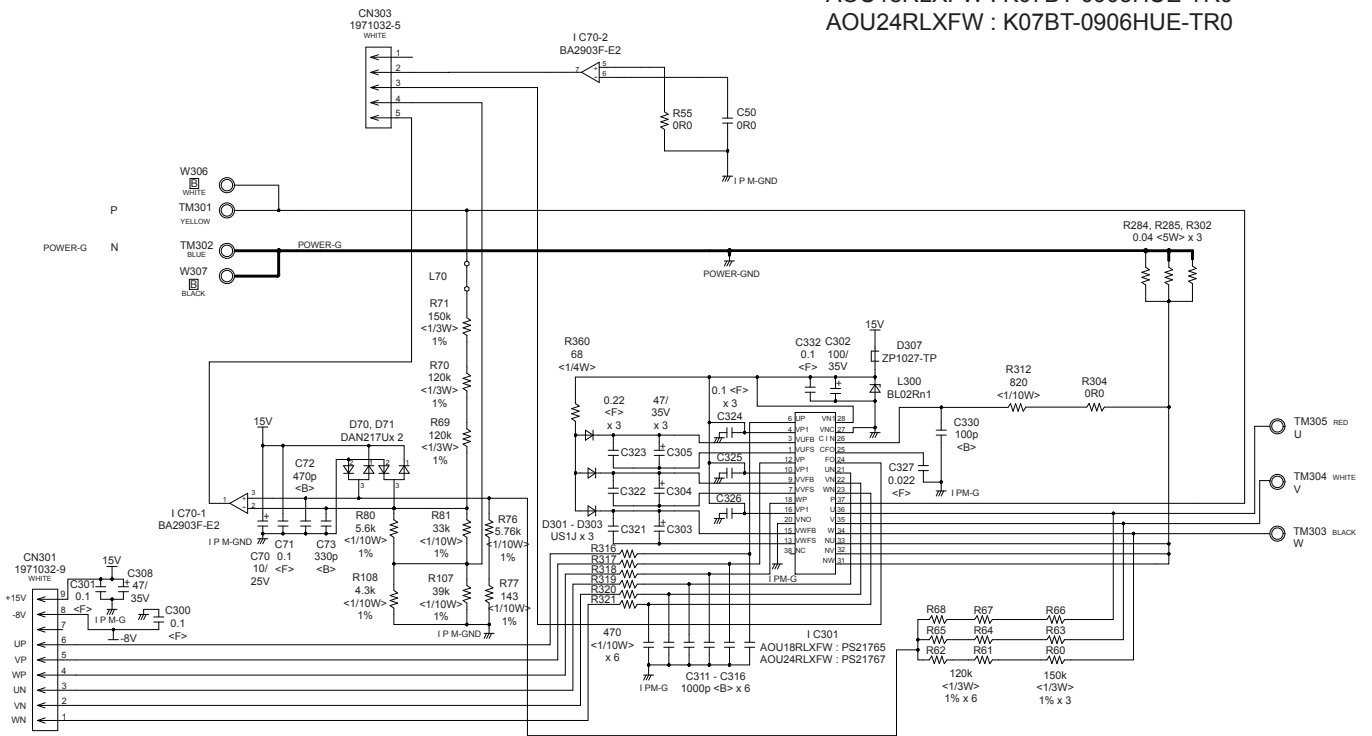

**OUTDOOR UNIT**  
**AOU18RLXFW**  
**POWER SUPPLY PCB ASSEMBLY**  
**K09DH-1001HUE-FL0**

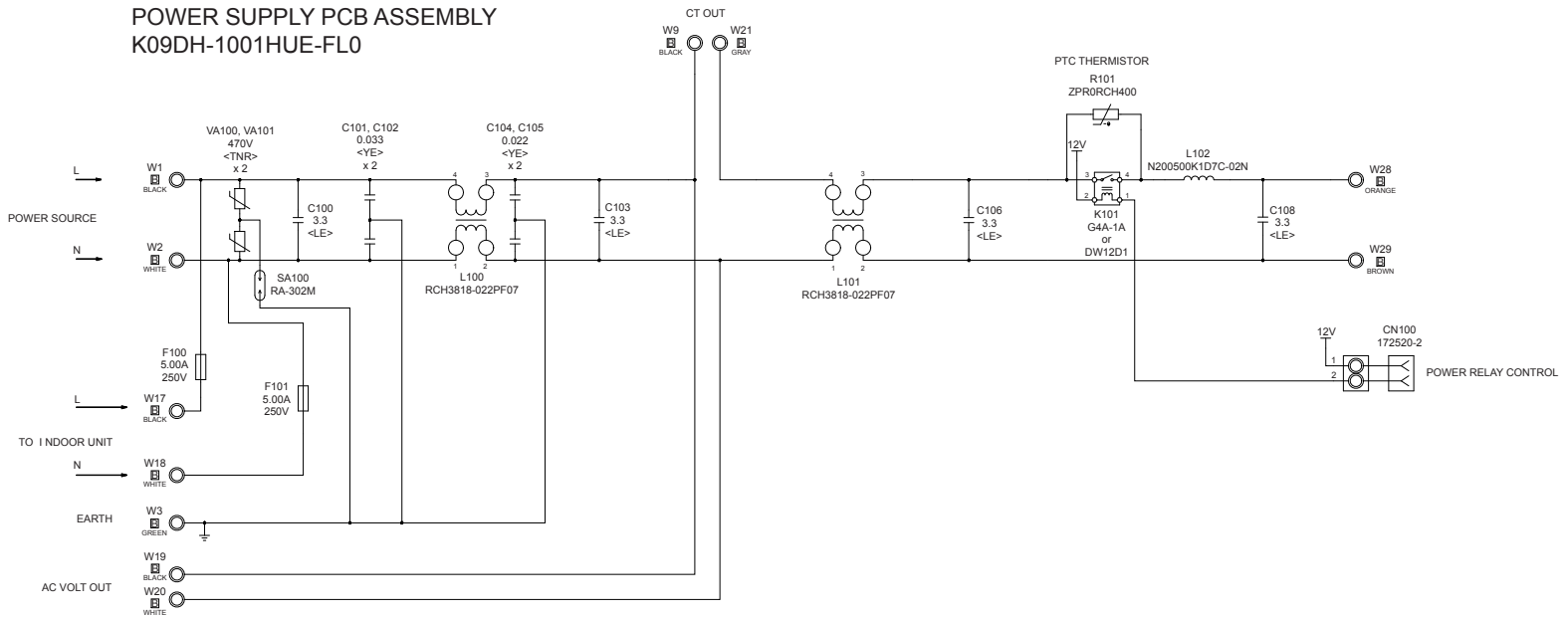

OUTDOOR UNIT  
 AOU24RLXFW  
 POWER SUPPLY PCB ASSEMBLY  
 K09DH-1002HUE-FL0

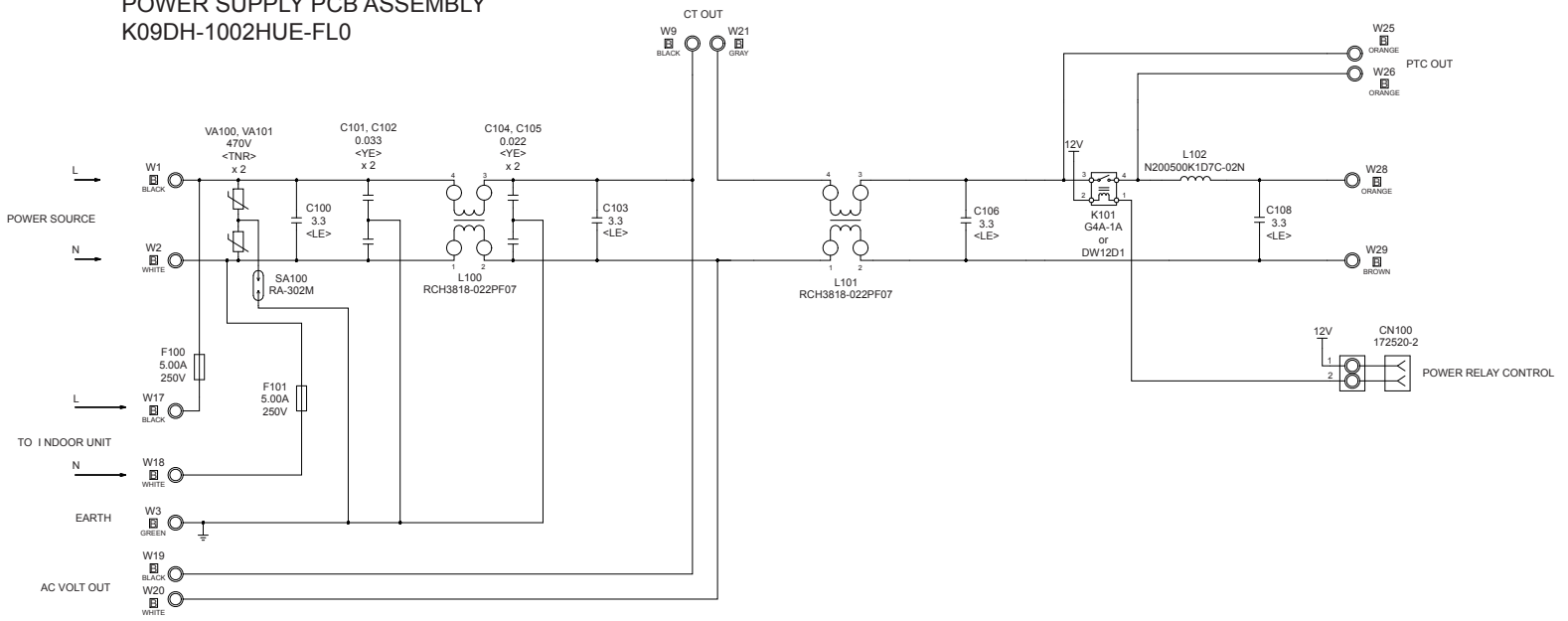

OUTDOOR UNIT  
AOU18RLXFW  
CAPACITOR PCB ASSEMBLY  
K05FB-0902HUE-P0

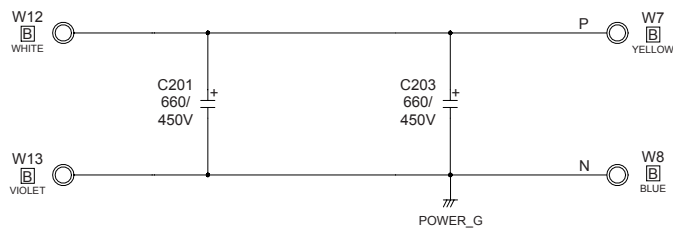

AOU24RLXFW  
CAPACITOR PCB ASSEMBLY  
K05FB-0903HUE-P0

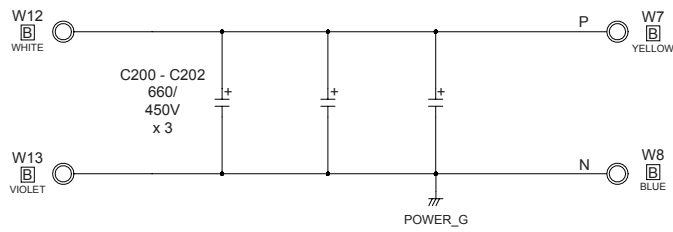

## ERROR DETECTION

● : 0.5s ON / 0.5s OFF

( ) : Number of flashing







◇ : 0.1s ON / 0.1s OFF

### INDOOR UNIT

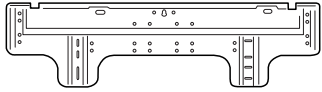
General section	Detail section	LED			Wired remote control error code
		OPERATION (Green)	TIMER (Orange)	ECONOMY (Green)	
Communication error System error	Serial communication error	● (1)	● (1)	◇	11
	Remote controller communication error	● (1)	● (2)	◇	12
	Scan error	● (1)	● (5)	◇	15
Field setting error	Initial setting error (for simultaneous multi)	● (2)	● (1)	◇	21
	Indoor unit capacity error	● (2)	● (2)	◇	22
	Connection disabled (series error)	● (2)	● (3)	◇	23
	Connection unit number error	● (2)	● (4)	◇	24
	Master unit and slave unit setting error	● (2)	● (7)	◇	27
	Indoor unit PCB, switch error	Indoor unit main PCB error	● (3)	● (2)	◇
Manual auto switch error		● (3)	● (5)	◇	35
Indoor unit sensor error	Indoor room thermistor error	● (4)	● (1)	◇	41
	Indoor heat Ex. thermistor error	● (4)	● (2)	◇	42
Indoor unit actuator error	Indoor unit fan motor error	● (5)	● (1)	◇	51
	Water drain error	● (5)	● (3)	◇	53
	Damper error	● (5)	● (7)	◇	57
	Indoor unit error	—	—	—	5U
Outdoor unit PCB error	Outdoor unit main PCB error	● (6)	● (2)	◇	62
Circuit parts error	Inverter PCB error	● (6)	● (3)	◇	63
	Active filter error, PFC circuit error	● (6)	● (4)	◇	64
Switch error	IPM error	● (6)	● (5)	◇	65
	Display panel error	● (6)	● (10)	◇	6A
Outdoor unit sensor error	Discharge thermistor error	● (7)	● (1)	◇	71
	Compressor thermistor error	● (7)	● (2)	◇	72
	Outdoor unit heat Ex. thermistor error	● (7)	● (3)	◇	73
	Outdoor thermistor error	● (7)	● (4)	◇	74
	Suction gas thermistor error	● (7)	● (5)	◇	75
	Operation valve thermistor error	● (7)	● (6)	◇	76
	Heat sink thermistor error	● (7)	● (7)	◇	77
	Outdoor unit sensor 2 error	Sub-cool heat Ex.gas thermistor error	● (8)	● (2)	◇
Liquid pipe thermistor error		● (8)	● (3)	◇	83
Current sensor error		● (8)	● (4)	◇	84
Pressure sensor error (Pressure sensor or switch error)		● (8)	● (6)	◇	86
Outdoor unit actuator error	Trip detection	● (9)	● (4)	◇	94
	Compressor motor control error	● (9)	● (5)	◇	95
	Outdoor unit fan motor 1 error	● (9)	● (7)	◇	97
	4-way valve error	● (9)	● (9)	◇	99
Refrigerant circuit error	Discharge temperature error	● (10)	● (1)	◇	A1
	Compressor temperature error	● (10)	● (3)	◇	A3
	Pressure error 1	● (10)	● (4)	◇	A4
	Pressure error 2	● (10)	● (5)	◇	A5

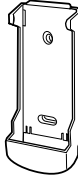

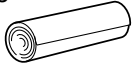
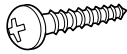
## ACCESSORIES

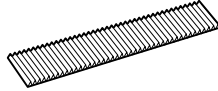
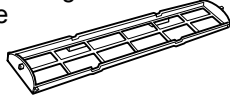
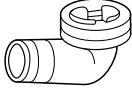
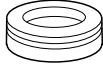
Name and Shape	Part number
Wall hook bracket 	9315023018
Remote control 	9379219013
Remote control holder 	9305642045
Battery (penlight) 	0600185541
Cloth tape 	9310519004
Tapping screw (big) 	0700076046
Tapping screw (small) 	0700019036
Air cleaning filter 	UTR-FA13-1 9312153060 UTR-FA13-2 9311925071
Air cleaning filter frame 	9368568009
Drain pipe (Outdoor unit) 	9301102000
Drain cap (Outdoor unit) 	313166024302

1011G3847

---