

FIFOTRACK 3G VEHICLE GPS TRACKER

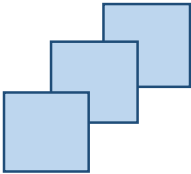
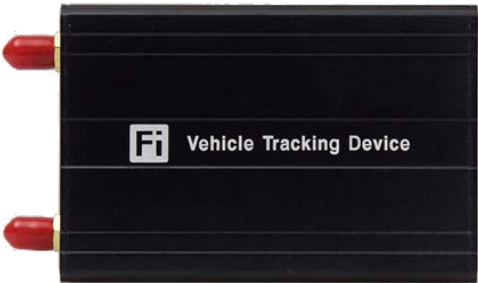

Model: A500

Version: V1.1

www.fifotrack.com

Copyright and Disclaimer

- ⦿ All copyrights belong to Shenzhen fifotrack Solution Co., Ltd. You are not allowed to revise, copy or spread this file in any form without consent of fifotrack.
- ⦿  is trademark of fifotrack, protected by law.
- ⦿ Please read this user guide carefully before installation to avoid any possible personal injury or property loss.

Revision History

Version	Author	Revision Date	Description of change
V1.1	Cici Wu	Oct 15, 2016	Initial revision

Related Files

Version	File	Remarks
V1.1	<fifotrack A500 GPRS Protocol and Command List>	GPRS protocol between terminal and server, command details of GPRS/SMS/COM
V1.1	<fifotrack Parameter Tool User Guide>	PC software tool for parameters configuration
V1.1	<USB Cable Driver Installation Guide>	How to install USB cable driver
V1.1	<Firmware Upgrade Guide>	How to upgrade firmware
V1.2	<fifotrack RFID Reader User Guide>	How to use RFID Reader
V1.1	<fifotrack iButton User Guide>	How to use iButton
V1.1	<fifotrack Digital Temperature Sensor User Guide>	How to use digital temperature sensor
V1.1	<fifotrack Camera User Guide>	How to use camera
V1.1	<fifotrack Ultrasonic Fuel Sensor User Guide>	How to use ultrasonic fuel sensor
V1.1	<fifotrack Fingerprint User Guide>	How to use fingerprint scanner
Download link: http://www.fifotrack.com/Support/Userguide/		

Related Software

Version	Software	Remarks
V1.0	<Parameter Tool>	Parameter configuration tool on PC
V1.11.0	<PL2303_Prolific_DriverInstaller>	Driver for USB cable
V1.0	< Firmware Upgrade Suite>	Tool for firmware upgrade
Download link: http://www.fifotrack.com/Support/Userguide/		

Contents

1 Product Overview	5
2 Product Functions	5
2.1 Tracking Functions	5
2.2 Alarms.....	5
2.3 Other Functions.....	6
3 Product and Accessories	6
3.1 Standard Packing Box	6
3.2 Optional Accessories.....	7
4 Product Appearance	7
5 PCBA Overview and Hardware Design	8
5.1 Hardware Design Highlight	8
6 LED Light	9
7 Specification	10
7.1 Basic Specification	10
7.2 Working Frequency.....	10
8 First Use	11
8.1 Charging.....	11
8.2 Installing the SIM Card.....	11
8.3 Installing GSM/GPS Antenna	12
8.4 Tracking by Calling	12
8.5 SMS Reply Content Example.....	13
8.6 Tracking by SMS Command - C01	14
8.7 Configuration by PC.....	14
8.8 Platform Tracking.....	15
9 Device Installation	15
9.1 I/O Installation.....	15
9.2 Power/GND Cable.....	17
9.3 Positive/Negative Digital Input (IN1/IN2/IN3/IN4)	18
9.4 Analog Input (AD)	18
9.5 Output control (OUT1/OUT2)	19

1 Product Overview

A500 is an advanced 3G model which is suitable for fleet management, public transportation management, school bus management, taxi operation management, vehicle insurance company management, rent car management and private car antitheft, etc.. A500 supports RS232 and 1-wire protocol, this enables A500 to have powerful functions such as photographing, driver identification and management, impulse detection and temperature monitoring.

Besides the advanced functions, A500 has full functions to cover the normal demands of vehicle tracking. Not only fuel monitoring, harsh acceleration/braking alarm, driving behavior analysis, but also has custom digital input, jamming detection, two-way calling and OTA function. A500 uses own FIFOTRACK GPRS PROTOCOL which is simple and practical; this enables the customers to integrate on their own platform efficiently.

2 Product Functions

2.1 Tracking Functions

- GPS+GSM Base Station Dual Tracking
- Real Time Tracking
- Time Interval Tracking
- Distance Tracking
- Direction Change Tracking
- Mobile Phone Tracking

2.2 Alarms

- SOS Alarm
- GPS Antenna Cut Alarm
- External Power Cut Alarm
- Engine/Door Status Alarm
- Maintenance remind
- GEO-Fence Alarm
- Speeding Alarm
- Idling Alarm
- Fatigue Driving Alarm

- Harsh Acceleration Alarm
- Harsh Braking Alarm
- Parking Overtime Alarm
- GPS Jamming Alarm
- GSM Jamming Alarm
- Internal Battery Low Alarm
- External Battery Low Alarm

2.3 Other Functions

- Stop Car Remotely
- 8 MB Flash Memory
- Custom Digital Input
- OTA
- Uploading Mode Settings for ACC ON/ACC OFF
- Roaming Time Interval Setting
- Mileage And Running Time Settings
- Tacking picture via camera (Optional)
- Driver identification and management via RFID Reader, i-Button, fingerprint scanner (Optional)
- Fuel sensor (Optional)
- Temperature sensor (Optional)
- Voice monitoring (Optional)
- Two-way Calling(Optional)
- Impulse detection (Default speedometer detection)

3 Product and Accessories

3.1 Standard Packing Box



Main Unit



Wire



GPS Antenna



GSM Antenna

3.2 Optional Accessories



USB Cable



Relay



Microphone



Speaker



AS10 Fuel Sensor



Calibrator



RFID reader



Tag



Camera



i-Button Reader



TUB01 ultrasonic fuel sensor



LED for TUB01



Fingerprint

4 Product Appearance

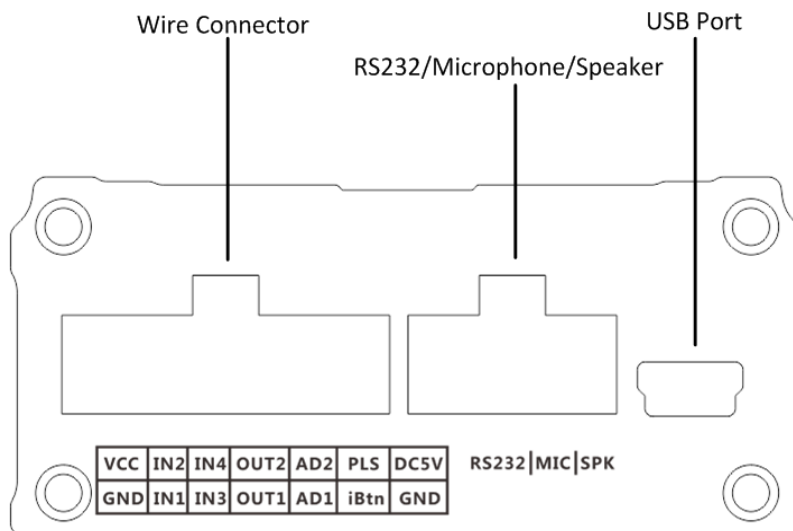

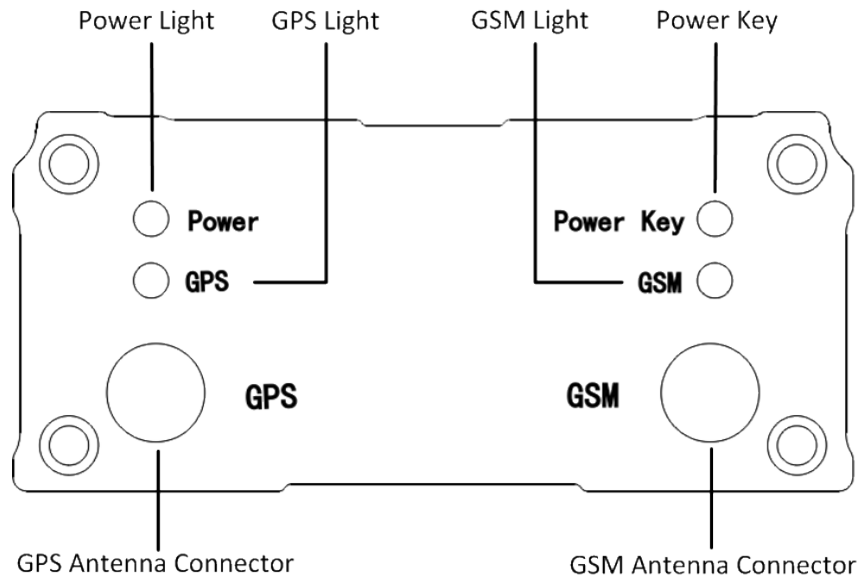

5 PCBA Overview and Hardware Design

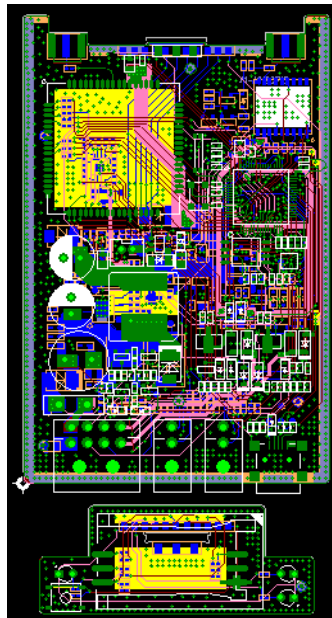

5.1 Hardware Design Highlight

Protection for sudden-change of auto power supply: When the vehicle starts or is running, the power voltage will have a wave of change. Our product supports voltage 11V-36V. When the external power supply is below 10.5V, with low voltage detection, it will be automatically cut. When external power supply is over 36V or has high voltage peak, the product will trigger high-voltage protection through

clamping, anti-pulse, and high voltage detection. This ensures the product to operate normally under high voltage.

Auto power transient pulse: When the vehicle starts or is running, it will generate high-voltage transient pulse with a range of hundreds of volts. If the product's circuit is not well designed, it is very easy to get damaged, and can't be used. Through multistage transient pulse protection and anti high-voltage surge protection, the product's power circuit is well protected, and it can operate stably.

Electromagnetic immunity: When the vehicle starts, the clock, RF, display screen and USB are very easy to be interfered by electric spark, which causes the product to operate unstably. Through PCB layout and ground wire handling, the product can work stably under interfered environment.

Anti static: The vehicle product's working condition is complex. It is very easy to be influenced by static, which causes damage to the product's peripheral interfaces. Through ESD protection on circuit and ground wire handling, the static in the range of 8KV-15KV won't cause damage to product. This ensures the product's stability under complex working condition.

6 LED Light

GPS Light (Green)	
Off	Power off or sleep
Flash 0.1s on and 3S off	GPS valid
Flash every 0.1s	GPS antenna cut
Flash 2s on and 2s off	No GPS signal
On	GPS module power problem
GSM Light (Orange)	
Off	Power off or sleep
Flash 0.1s on and 3s off	GSM available
Flash every 0.1s	Device is initialing
Flash 2s on and 2s off	No GSM
External Power Light(Red)	
Off	External power cut
Flash every 0.1s	External power low
On	External power normal

7 Specification

7.1 Basic Specification

Item	Specification
Dimension	90*60*27mm
Weight	145g
GSM Module	Quectel UC15
GSM Frequency	Refer to chapter 7.2
GPS Module	U-blox7Q
Input Voltage	DC 11~36V/1.5A
Internal Battery	600mAh/3.7V
Power Consumption	30-65mA standby current
Internal Battery Life	100 hours in sleep mode, and 10 hours in normal working mode.
Operating Temperature	-20°C~70°C
Humidity	5%~95%
LED Light	3LED lights indicating GPS/GSM/External power status
Button/ Switch	1SOS Button, 1 power switch
Flash Memory	8MB(GPSR data 20400 units, SMS data 300 units)
Sensor	3D Accelerator sensor
GPS Sensitivity	-161dBm
GPS Start Speed	Cold start 35s Hot start 1s
Position Accuracy	10m
I/O Port	4 digital input - 1 negative input, 1 positive input, 2 custom input (Default 1 positive input, 1 negative input) 2 analog input, voltage range: AD1 ~ 0~6V AD2 ~ 0~12V 2 output 1 RS232 port (camera/RFID reader/ultrasonic fuel sensor/fingerprint) 1-wire protocol (temperature sensor/i-Button) 1 Impulse detection (Default speedometer detection) 1 USB port

7.2 Working Frequency

A500 Type	UMTS Frequency/MHz				GSM Frequency/MHz			
	850	900	1900	2100	850	900	1800	1900
Type-A	■		■		■	■	■	■
Type-E		■		■		■	■	
Type-T	■			■	■	■	■	■

8 First Use

8.1 Charging

First time use A500, please connect positive wire(+ Red) and ground wire(-black) to 12V or 24V external power supply, charging device for at least 2 hours, 3 hours is suggested. Before installation, ensure all of the parameters setting and test are finished.

8.2 Installing the SIM Card

- Device supports 2G and 3G network.
- Ensure the SIM card has enough balance.
- Ensure PIN code has been closed.
- Authorization SOS numbers can't work well if SIM card doesn't have caller ID service. E.g.: device can't reply SMS to authorization SOS number because SIM card can't identify incoming call.
- SIM card should have GPRS function for platform tracking.
- Turn off device before SIM card installation.

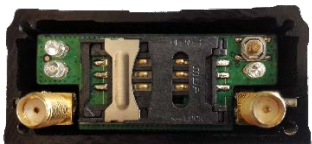

Screw off and open the front cover



Insert SIM card into SIM card slot

Make sure the chip is facing to PCB. Pay attention to the cutaway angle direction of SIM card.



Close front cover and lock the screw

8.3 Installing GSM/GPS Antenna

Connect GSM Antenna to SMA connector with “GSM” silk. The GSM antenna’s signal is omnidirectional, you can hide it anywhere that is far from the power supply.

Connect GPS Antenna to SMA connector with “GPS” silk. GPS antenna should face to the sky for stronger GPS signal reception, and the silvery silk side should be downward. Fix GPS antenna with double sided tapes for stable signal reception.

 Don’t install the GPS antenna where shielded by metal. For example, inside a metal can.

8.4 Tracking by Calling

Call the SIM card number inside A500, you will get a SMS reply with Google map link. Click it for specific map location.

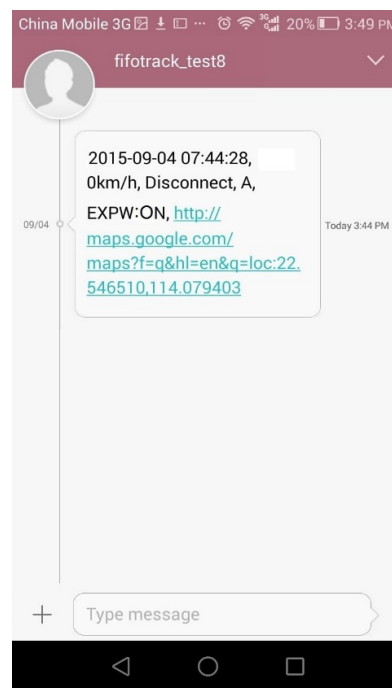
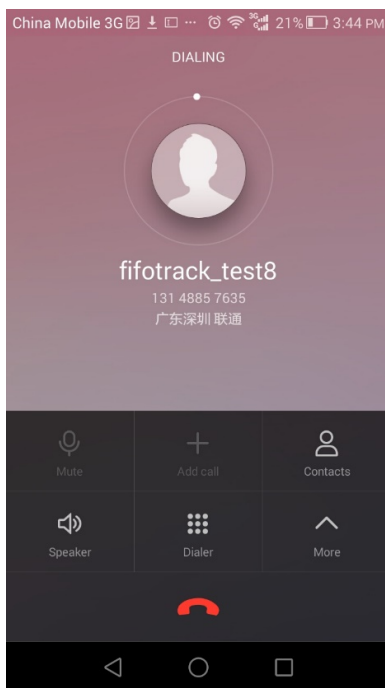



8.5 SMS Reply Content Example

2015-09-04 07:44:28, 0km/h, Disconnect, A, EXPW:ON,<http://maps.google.com/maps?f=q&hl=en&q=loc:22.546510,114.079403>

SMS Reply Format:

Field	Detail	Remarks
2015-09-04 07:44:28	Date and time, format YYYYMMDD hh:mm:ss	Date and time
0km/h	Speed is 0km/h	Speed
Disconnect	GPRS disconnect	GPRS connection status, "Disconnect" or "connect".
A	GPS valid	GPS Status, "A" means GPS valid, "V" means GPS invalid.
EXPW:ON	External power on	External power status. "ON" means external power normal, "OFF" means external power cut.
http://maps.google.com/maps?f=q&hl=en&q=loc:22.546510,114.079403	Google map link, latitude in the front of longitude after "Loc". Unit degree Latitude=22.546510° Longitude=114.079403°	Google map link with latitude and longitude, which can be opened directly on smart phone.

8.6 Tracking by SMS Command - C01

SMS Command: 000000,C01

SMS Reply: Current location

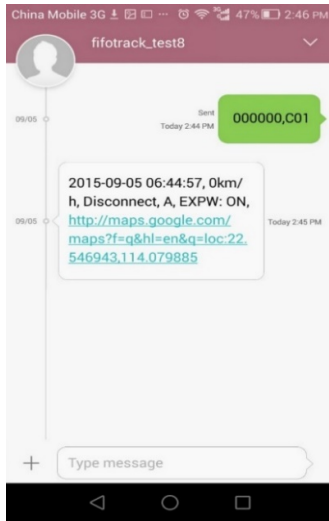

Note: Default SMS password is “000000”, set new SMS password with B10 command.

Please refer to <FIFOTRACK COMMAND LIST>for more details.

8.7 Configuration by PC

fifotrack company provide <FIFOTRACK PARAMETER TOOL> for configuration. Please download USB cable driver and install it before using parameter tool. Refer to <USB CABLE DRIVER INSTALLATION GUIDE> if need.

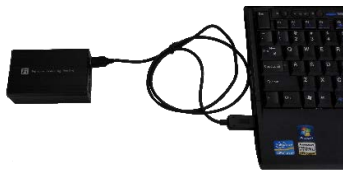

Connect A500 to PC with USB cable. Run “fifotrack Parameter Tool” software which will identify port automatically and read all of the current parameters.

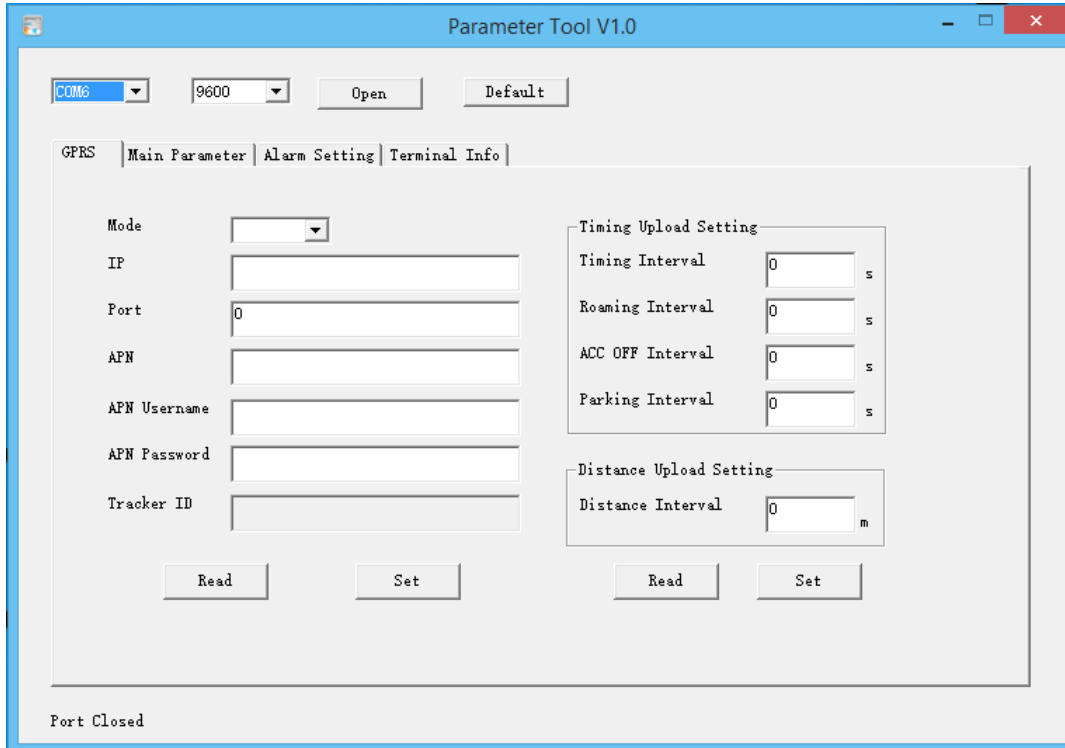

Please read <FIFOTRACK PARAMETER TOOL USER GUIDE> for more details.

8.8 Platform Tracking

You can use SMS commands B00, B01, B02, B03 to set server IP, port, APN and GPRS uploading interval.

You can also set those parameters via parameter tool software on PC.

9 Device Installation

9.1 I/O Installation

I/O wire has 14 pins, including power, digital positive and negative input, output, analog input, impulse detection and 1-wire protocol cables.



VCC	IN2	IN4	OUT2	AD2	PLS	DC5V
GND	IN1	IN3	OUT1	AD1	iBtn	GND

I/O	Color	Function
VCC	Red	Positive power, connect to positive of vehicle battery, input voltage range 11-36V
GND	Black	GND, connect to negative of vehicle battery or the vehicle's iron part.
IN2	White	Digital input2, positive input, default connect to ACC for status detection.
IN1	White	Digital input1, negative input (default SOS button)
IN4	White	Digital input4, custom input, default negative.
IN3	White	Digital input3, custom input, default positive.
OUT2	Yellow	Output2 Output active: low level (0V) Output inactive: open drain (OD) Max open-drain (inactive) voltage: 45V Max current for output low voltage (valid): 500mA
OUT1	Yellow	Output1 Output active: low level (0V) Output inactive: open drain (OD) Max open-drain (inactive) voltage: 45V Max current for output low voltage (valid): 500mA
AD2	Blue	12 bits analog input, supports voltage range 0-12V. Connect to external sensor, e.g., fuel sensor.
AD1	Blue	12 bits analog input, supports voltage range 0-6V. Connect to external sensor, e.g., fuel sensor.

PLS	Brown	Impulse detection, 0~100kHz
GND	Black	
DC5V	Orange	
iBtn	Purple	

RS232|MIC|SPK Port

DC5V	MCU_RS232_TX	MIC+	SPK+
GND	MCU_RS232_RX	MIC-	SPK-

I/O	Function
DC5V	RS232 port for camera/RFID Reader/Ultrasonic fuel sensor/fingerprint scanner or other RS232 interface devices.
GND	
MCU_RS232_TX	
MCU_RS232_RX	
MIC+	Microphone port
MIC-	
SPK+	Speaker port
SPK-	

9.2 Power/GND Cable

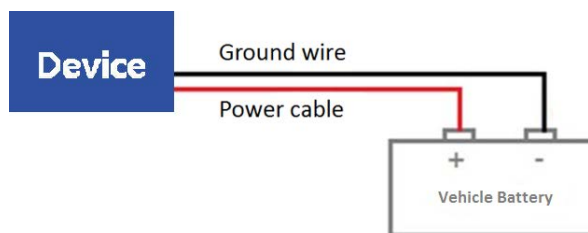

9.3 Positive/Negative Digital Input (IN1/IN2/IN3/IN4)

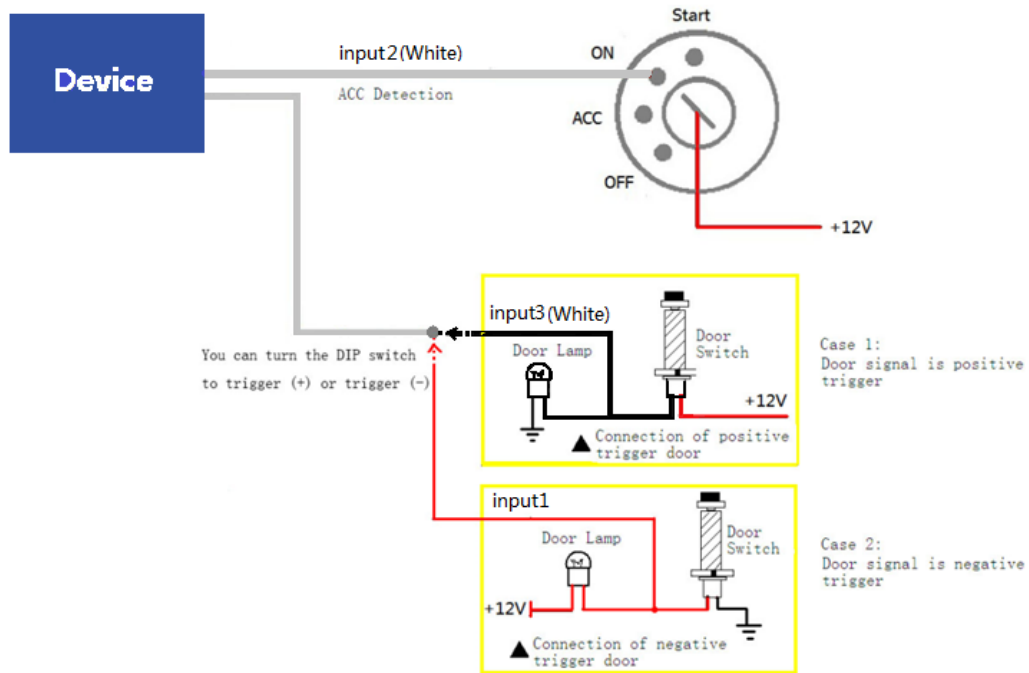

9.4 Analog Input (AD)

A500 supports 2 AD input, whose voltage range:

AD1: 0~6V

AD2: 0~12V

Calculation formula:

AD1 Voltage=(AD1)*3300*2/4096

AD2 Voltage=(AD2)*3300*62/(4096*15)

Note: Original AD value is in hexadecimal. Convert it to decimal first, and then use the formula.

9.5 Output control (OUT1/OUT2)

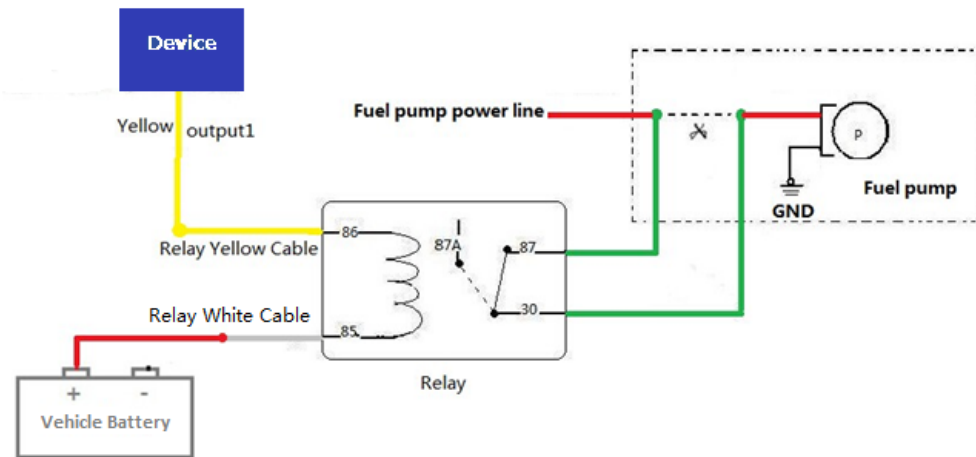

Please e-mail us at info@fifotrack.com if any question or feedback.