



Close Control Small Systems Range



**Engineering Data Manual 50/60Hz
R407C**

Index

Description	Page
EDPAC Company Profile	3
This Product Range	3
Other EDPAC Close Control Product Ranges	3
Equipment Nomenclature	4
Indoor Units - Dimensions and Weights	4
Air Cooled Condensers - Dimensions and Weights	5
Guide Specifications	6
General Engineering Details	11
Air Cooled Unit Schematic	12
Chilled Water Unit Schematic	13
Air Cooled Units - Cooling Capacities 50Hz	14
Air Cooled Units - Cooling Capacities 60Hz	14
Chilled Water Units - Cooling Capacities 50/60Hz	15
Electrical Details - Air Cooled Units, 400V/50Hz	16
Electrical Details - Air Cooled Units, 220V/60Hz	16
Electrical Details - Air Cooled Units, 380V/60Hz	17
Electrical Details - Air Cooled Units, 460V/60Hz	17
Electrical Details - Chilled Water Units, 400V/50Hz	18
Electrical Details - Chilled Water Units, 220V/60Hz	18
Electrical Details - Chilled Water Units, 380V/60Hz	19
Electrical Details - Chilled Water Units, 460V/60Hz	19

While every precaution has been taken to ensure accuracy and completeness in this manual, EDPAC assumes no responsibility and disclaims all liability for damages resulting from use of this information or for any errors or omissions.

Document Reference: E.4.19-01-03-05

EDPAC COMPANY PROFILE

HISTORY

Formed in 1968, EDPAC has grown through worldwide distribution to an installed base of over 50,000 units. EDPAC currently services the markets of Europe, the Americas, the Middle East, and the Far East. As one of the pioneers of Precision Air Conditioning the EDPAC name has become synonymous with quality and reliability. With its highly skilled and experienced team EDPAC has established not only a modern manufacturing plant, but also a sophisticated and innovative product development programme. Since 1987 EDPAC International located in Cork Ireland, has controlled the entire activities of the group.

PRODUCT RANGE

EDPAC manufactures a broad range of Precision Air Conditioning equipment for the Computer Room, Telecoms and other critical Building Services applications. EDPAC systems are designed to provide optimum operating conditions in close control environments.

QUALITY

All suppliers of materials and components used in manufacturing are assessed and qualified by EDPAC. The EDPAC guarantee of quality is also complimented by rigorous in-factory quality assessment and quality control testing prior to product dispatch. The overall activity of the factory is customer focused and conforms to the strict norms of IS/ISO9001/EN29001. EDPAC was awarded and has retained this certificate since 18th March 1992.

THIS PRODUCT RANGE

SMALL SYSTEMS

The Small Systems range comprises 2 module sizes providing nominal capacities of 6, 12 and 18 kW per module. The modules form the basis of the EDPAC Small Systems concept. Unit selections are based on a single module. Units are available in downflow with top return and upflow with front return. Cooling media include direct expansion using air and chilled water. The Small Systems Range Units are equipped with: Scroll Compressors, Electrode Steam Boiler Humidifiers, Stainless Steel Tubular Finned Electric Reheat, EU4 Filtration, Belt Driven forward curved Centrifugal Fans and R407C Refrigerant. BMS interface cards are available for all of the most commonly-used protocols including but not limited to MODBUS, BACnet, LON, JCI METASYS & they all can be integrated into most BMS systems by RS 485 or over TCP/IP. Cooling media available is air cooled direct expansion only. There is an option for a dual cooling version with the addition of a chilled water coil.

ASSOCIATED PRODUCT RANGES

CLOSE CONTROL MODULAR UNIT RANGE

The Close Control Modular range is comprised of 4 module sizes providing nominal capacities of 10, 15, 20, 25, 30, 35 & 40 kW per module. These modules form the basis of the EDPAC modular concept. Unit selections can be based on a single module for a single circuit system or any combination of 2 modules to give a twin circuit or Duplex system. The Duplex configuration is advantageous as both modules can be positioned at different locations within the room.

CLOSE CONTROL AIR COOLED TWIN CIRCUIT UNIT RANGE

The Close Control Twin Circuit range comprises 4 sizes providing nominal capacities of 30, 40, 50, 60, 70, 80 & 100 in 10kW increments. Units are twin circuit in a single frame and are available in upflow and downflow configurations. Cooling media available is air cooled direct expansion only. There is an option for a dual cooling version with the addition of a chilled water coil.

EC PLUG FAN UNIT RANGE

The EC Plug Fan range comprises of 7 sizes providing nominal capacities of 20-200kW. All units are fitted with the EC plug fans and cooling media include direct expansion using air and chilled water.

TELECOM SYSTEM UNIT RANGE

The Telecom System Unit range comprises of split DX units consisting of an indoor evaporator and outdoor condensing unit. There are 3 unit sizes giving capacities of 5 to 20kW. The indoor unit can be wall or ceiling mounted optimising available room space. Units are also available with freecooling & are ideally suited for small telecom sites, base stations and electrical rooms.

SELF CONTAINED UNIT RANGE

The Self Contained Unit range comprises of wall mounted self-contained DX units. There are 3 unit sizes giving capacities of 5 to 20kW. Units are mounted externally conserving internal floor space. Units are also available with freecooling & are ideally suited for telecom sites and base stations.

EQUIPMENT NOMENCLATURE

The Small Systems range comprises 2 module sizes providing nominal capacities of 6, 12 and 18 kW. Units are available in downflow with Top return and upflow with front and rear return options. Cooling media include direct expansion using air or water/glycol and chilled water. The Small Systems Range Units are equipped with: Scroll Compressors, Electrode Steam Boiler Humidifiers, Stainless Steel Tubular Finned Electric Reheat, EU4 Filtration, Belt Driven forward curved Centrifugal Fans, R407C Refrigerant and the latest BES/BMS compatible range of Delta microprocessor controllers.

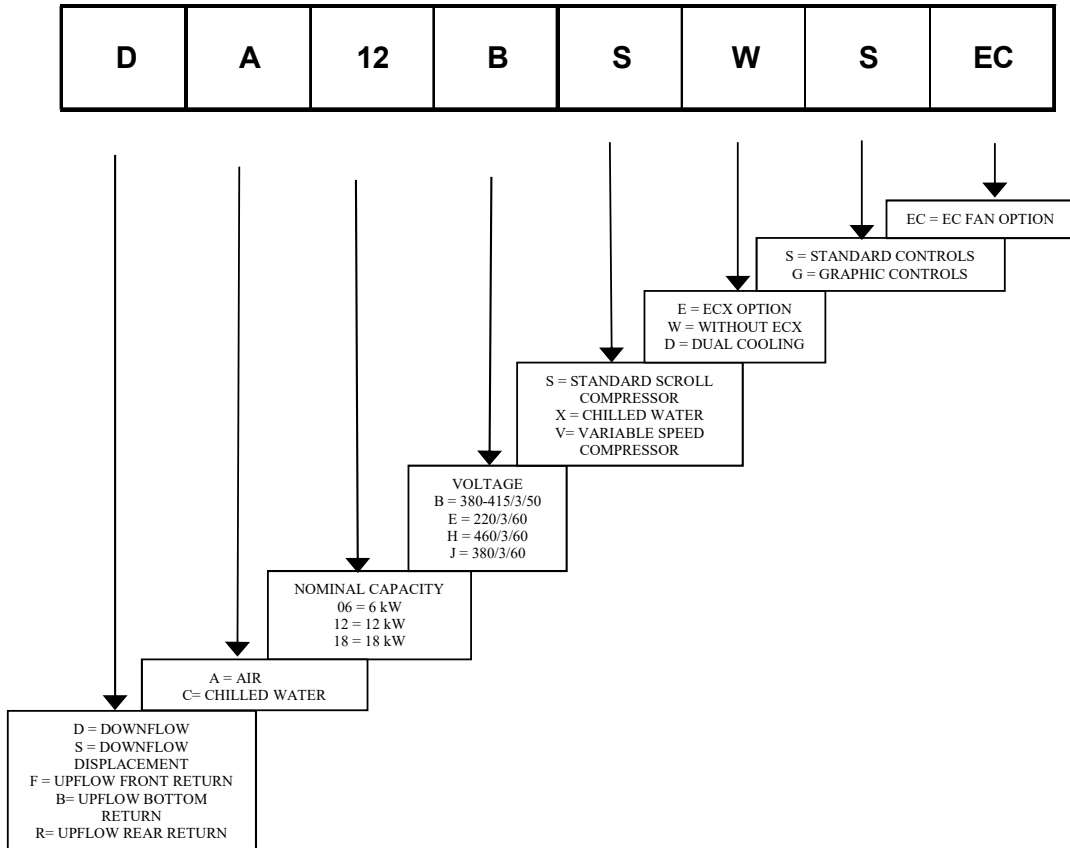

DIMENSIONS AND WEIGHTS

Dimensions (mm)

Model	06	12	18
Unit W x D	600 x 600	600 x 600	775 x 775
Height	1980	1980	1980

Weight (kg)

Model	06	12	18
Air Cooled	305	320	340
Chilled Water	250	260	280

CONDENSERS – DIMENSIONS AND WEIGHTS
30°C Ambient Selection

Model	06	12	18
Condenser Model x 1	AGS 501A	AGS 501A	AGS 501B
Condenser Input Power (kW)	0.7	0.7	0.7
Free field SPL @ 10m dBA	43	43	43
Airflow (m ³ /h)	8250	8250	7850
Dimensions W x D (mm)	1050 x 825	1050 x 825	1050 x 825
Weight (kgs)	39	39	42

35°C Ambient Selection

Model	06	12	18
Condenser Model x 1	AGS 501A	AGS 501B	AGS 501C
Condenser Input Power (kW)	0.7	0.7	0.7
Free field SPL @ 10m dBA	43	43	43
Airflow (m ³ /h)	8250	7850	7500
Dimensions W x D (mm)	1050 x 825	1050 x 825	1050 x 825
Weight (kgs)	39	42	47

40°C Ambient Selection

Model	06	12	18
Condenser Model x 1	AGS 501A	AGS 501C	AGS 502A
Condenser Input Power	0.7	0.7	1.4
Free field SPL @ 10m dBA	43	43	46
Airflow (m ³ /h)	8250	7500	16500
Dimensions W x D (mm)	1050 x 825	1050 x 825	1950 x 825
Weight (kgs)	39	47	76

45°C Ambient Selection

Model	06	12	18
Condenser Model x 1	AGS 501A	AGS 502B	AGS 502C
Condenser Input Power (kW)	0.7	1.4	1.4
Free field SPL @ 10m dBA	43	46	46
Airflow (m ³ /h)	8250	15700	15000
Dimensions W x D (mm)	1050 x 825	1950 x 825	1950 x 825
Weight (kgs)	39	85	93

50°C Ambient Selection

Model	06	12	18
Condenser Model x 1	AGS 501C	AGS 502C	AGS 503B
Condenser Input Power (kW)	0.7	1.4	2.1
Free field SPL @ 10m dBA	43	46	48
Airflow (m ³ /h)	7500	15000	23550
Dimensions W x D (mm)	1050 x 825	1950 x 825	2850x825
Weight (kgs)	47	93	123

Notes:

1. Standard Air Cooled Condensers have 4 Pole motors. For 6 Pole & 8 Pole low noise versions, consult factory.
2. All Condensers are shipped with mounting feet. When mounted in a horizontal, Condenser models AGS 501-503 are 850mm high.

STANDARD FEATURES

Cabinet

The cabinet frames shall be constructed of formed 2.0 mm Zintec steel sections. Paint finish is Epoxy Powder Coated with an “Orange Peel” textured finish. Interior panels to be manufactured from galvanised steel in all cases. Exterior panels are to be as cabinet except in 1.2 mm Zintec. Paint Colour to be RAL 9018. The front panels shall be fastened to the frame using quarter turn fasteners. Side panels shall be secured to the frame using chrome plated screws. All panels shall be flush fitting, sealed to the frame sections with closed cell foam and insulated with a non-shedding material, which shall be non-combustible, when tested in accordance with B.S. 476 Part 6 and 7. The units shall be fully accessible and serviceable from the front.

Cooling Coil

The cooling coils shall be multi-row constructed from 10mm O/D copper tubes with aluminium fins. Large surface areas shall ensure high sensible heat ratios and low airside pressure drops, resulting in reduced fan power requirements and noise levels. All DX coils shall be tested to 25 bar.

DX Units

Each unit shall have 2 independent refrigerant circuits, each with a liquid distributor, expansion valve, sight glass and filter drier.

Fans

Large, low speed, double inlet, double width fans with forward curved impellers and “sealed for life” self-aligning bearings shall be used to minimize noise levels. Fans are belt driven. All units have twin fans on a common shaft. The fan/motor assembly is on a separate isolated deck.

Twin Belts

Twin grooved pulleys and twin belts giving a fixed speed are provided for each fan assembly.

Motors

The motor shall comply with IP55 TEFC insulated to Class F.

Filtration

The filters shall be 100mm thick disposable pleated panel filter rated G4 in accordance with EN779. They shall be fitted in the return air stream and be accessible from the front of a Upflow unit and the top of a Downflow unit.

Compressors

Compressors shall be high efficiency hermetically sealed scroll type. Back seating service/isolating valve, high and low pressure switches, motor overload protection and crankcase heaters shall be provided. The compressors shall be mounted on resilient neoprene mountings for vibration isolation.

Electrical Panel

The electrical panel shall be constructed and assembled in compliance with IEC standards with all components VDE approved. All sub circuits are protected by MCB's. The high and low voltage sections shall be segregated and all high voltage electrical components shall be touch safe.

Electric Heaters

Electric heaters shall have stainless steel sheathed elements with stainless steel finning, balanced over three phases and rated to operate at black heat. Control shall be in two stages. Protection is by a high temperature safety cut-out stat. The stat shall be a capillary type mounted in the airstream resettable from the control section of the electrical panel.

Humidification

The humidifier shall be of the electrode-boiler type. Features shall include selectable steam output and microprocessor control with alarms and diagnostic facilities. The humidifier control system shall allow the use of a wide range of mains water conditions namely: inlet mains water pressure of 1-10 bar, total hardness of 15-30 French degrees & water inlet electrical conductivity of 400-800 micro siemens. Unit shall optimize drain down frequency for maximum operational economy.

Microprocessor Controls

All units shall be fitted as standard with the latest Delta range of DIN rail mounted Microprocessor Controls. The Control System utilizes a main Microprocessor Interface Board equipped with a set of terminals necessary to connect the Board to the controlled devices (e.g. valves, compressors, fans, reheats, sensors and humidifiers). All software is permanently stored in flash RAM and is therefore protected even in the event of a power failure. Unit software is uploaded to the Microprocessor using a RAM key or personal computer. On multi-unit sites this quickens unit commissioning. The software can also be easily changed or upgraded on site by qualified service personnel.

The Microprocessor based Terminal Unit is complete with a 4 line x 20 character backlit LCD Display, keypad and LED Indicators allowing the user to easily set the main control parameters (set-points, differentials and alarm thresholds) and carry out the main working operations (on/off and displaying controlled variables).

Main features of controller are :

Status: The display shall indicate current temperature, current humidity, temperature & humidity set points, cooling status, heating status, humidification status & dehumidification status.

GUIDE SPECIFICATIONS

Redundancy Management & Master Control: The controls shall be capable of redundancy management & master control setup / “Handshake” of groups of up to 16 units without addition of any hardware.

Alarms: Controls shall be capable of storing last 100 alarms, identified by type, date stamped & indicating also the temperature & humidity conditions when the alarm occurred & also the setpoints of temperature & humidity when the alarm occurred. There are 36 alarms & all alarms can be either set as “serious” or “non-serious”. A serious alarm shuts down the unit.

Hours Thresholds: It shall be possible to set run hours thresholds for major components to facilitate preventative maintenance.

Manual Procedure: With the unit powered off & the controls powered on it shall be possible to check all analogue & digital outputs & to run the devices.

Temperature & Humidity Zone setback: It shall be possible to create up to 4 periods in a 24 hour period with dedicated set points of temperature & humidity.

System Auto Restart: For startup after power failure, the unit shall automatically restart with an ability to stagger the starting of multiple units by setting a time delay of up to 999 seconds.

Security: The microprocessor shall have multiple levels of security (5 no. 4 digit passwords) to prevent unauthorized parameter adjustment.

Time Delays: It shall be possible to create or adjust if necessary the unit on time delay, unit off time delay, compressor interstage delay, compressor minimum run time, compressor minimum stop time, heater interstage delay, winter start time delay, temperature alarm time delay, humidity alarm time delay, serious alarm time delay & non-serious alarm time delay.

Sensor Calibration: It shall be possible to recalibrate the temperature & humidity sensors in software.

Inputs / Outputs: It shall be possible to view the current status of all inputs & outputs while the unit is running.

Set & Hysteresis adjustment: It shall be possible to adjust the set & hysteresis % values of stepped outputs within the control.

BMS / BAS interfacing: It shall be possible with the addition of a simple communications card to communicate all Analog, Digital & Integer variables in the following protocols : LON FTT 10, BACnet over RS485 MSTP, BACnet over TCP/IP, SNMP over TCP/IP, MODBUS over RS485, Metasys & OPC Server.

Remote Display panel: It shall be possible to connect an additional shared LCD display which is wired back to the unit & this remote display shall have full control access to the unit from a distance of up to 100m.

Remote Temperature & Humidity sensing: It shall be possible to remotely locate the Temperature/Humidity sensor to better meet the sites cooling needs. The sensor can be located a distance of up to 30m from the unit.

OPTIONAL FEATURES

EC Plug Fans

Available instead of forward curved belt driven fans. The EC plug fan is a backward curved fan with integrated EC electrically commutated motor which is controlled directly from the microprocessor using a 0-10V output. Options on setup are :

Unit is set up with a discrete fan speed based on a fixed 0-10V output to the EC motor based on the design point of operation of the fan. This is the default setting on units shipped.

Unit set up to track the cooling control temperature band with set voltage limits whereby max voltage / fan air volume is at set point plus control band & min voltage / fan air volume at set point. Max air volume is typically design air volume & min air volume is around 60% for chilled water units. This is something that can be proven on site. Minimum value needs to ensure there are no hot spots due to lack of airflow & that there is no loss of sensible cooling capacity to latent cooling capacity at the cooling coil.

Unit set up to give a reduced fan air volume in dehumidification mode to conserve energy in dehumidification while quickly achieving the dehumidification effect at the cooling coil. This output voltage is again user selectable.

Unit is set up via an underfloor pressure transducer to give a fixed underfloor pressure all the time. Underfloor pressure setpoint is input through the unit user display.

3 Stage Reheat

Available in lieu of 2 stage by adding an electrical contactor & configuring the software to 3 stage.

Proportional Electric Reheat

Units shall be fitted with electric reheat controlled by a thyristor giving a fully proportional 0-10V output of the reheat capacity.

Hot Water Reheat

Units shall be fitted with a Low Pressure Hot Water (LPHW) heating coil in place of the standard electrical heating. Water flow through the coil is controlled by a 2 or 3 way modulating valve. Duties of these coils are nominally the same as standard electric heating, based on flow and return hot water temperatures of 82°C and 71°C respectively.

Cleanable Humidifier Cylinder

Humidifier cylinder is servicable whereas standard humidifier cylinder is disposable.

Low Conductivity Humidifier Cylinder

Disposable type but for water supply with low electrical conductivity.

Upsized Fan Motors

For applications where fan power requirements exceed the capacity of the standard motors, an upsized motor can be fitted. Standard unit ESP is 75 Pa. Units can normally be upgraded to 200 Pa or 400 Pa. In these instances please advise the factory on ESP Pa required.

Floor Stand

Floorstands are shipped flat-pack and need to be assembled on site. They are suitable for raised floor heights of 150mm to 600mm. The legs are notched at 50mm intervals for cutting on site. There is also a final adjustment on the foot of +/- 50mm. Scoops are also available as an option with the floorstand. Floorstands and scoops are manufactured from galvanized steel.

Damper & On/Off Actuator Kit

Addition of a damper & on/off actuator shipped loose which can be integrated into floorstand of downflow unit & to discharge of upflow unit. Actuator powered from unit electrical panel.

Air Discharge Plenum

For Upflow units which are to be installed in a freeblow situation. Plenum consists of an insulated sheet metal assembly with 3 discharge grilles. Grilles are double deflector type. Plenum colour will match unit colour. Plenums can also be manufactured as 1 way or 2 way discharge, please consult factory.

3 way discharge plenum complete with up to F9 rigid bag filters.

Plenum is mounted on top of unit. Plenum is 1000mm high with a 292mm long F9 rigid bag filter. Plenum has a diffusion section and 3 no. Air outlet grilles. Grilles on the front and 2 sides. It is also possible to have the F8/F9 discharge section on its own, plenum is 400mm high.

Rear Return

For upflow units. Required when unit is located in a service area outside the conditioned space. Fan deck is turned through 180 degrees. Return air is taken in the rear. Rear panel generally has a duct connection and filters are withdrawable from outside the unit.

Bottom return

For upflow units. Required if air is returned from a floor void. Bottom of unit is opened up and base components are mounted on rails. Filters cannot be fitted in unit and are shipped loose for installation beneath the unit on site.

GUIDE SPECIFICATIONS

Return Air Attenuator 500mm high.

Attenuator mounted on top of downflow unit. Attenuators have internal baffles and provide 8-10 db reduction on airborne noise.

F5/6/7 Panel Filters

Upgrade of standard G4 disposable panel filters to F5/6/7 disposable panel filters.

G2 Pre-filter with G4 Main Filter

100mm G4 disposable filter replaced with 50mm G2 disposable plus 50mm G4 disposable filter.

Washable Filters

Upgrade of standard disposable 100mm G4 disposable filters to washable 50mm G3 type plus 50mm G4 disposable filter.

Filter Clog

An additional pressure differential switch mounted in the unit to sense airside pressure drop across the filters. Once the pressure drop is exceeded a filter clog (filter change) alarm is generated.

Different Unit Colour

Units can be manufactured in a different colour to the standard RAL 9018. RAL number to be specified.

Double Skin Panels

All units. Inner perforated galvanized steel or solid painted or unpainted galvanized steel.

Fresh Air Connection

Units can be supplied with a fresh air inlet connection and disposable G4 filter. This will admit approximately 3-5% of the recirculated air volume.

Hot Gas Bypass

Hot gas bypass line including hot gas bypass valve fitted to provide capacity control in low load situations.

Liquid Receiver

Liquid receiver fitted in unit base of indoor unit. Receiver is complete with rotalock valve on the discharge.

Oil Separator

Oil separator fitted in indoor unit to prevent migration of oil away from compressor.

Compressor Acoustic Jacket

High mass barrier insulation to reduce compressor noise.

Condensate Pump

Where, due to location, it is not possible to gravity drain units, a condensate pump can be fitted to collect any condensate and pump it to the nearest convenient drain point (pump duty is 6 l/min Vs 6 m head). A cheaper cold condensate pump is available for units without humidifiers.

Handshake - Autosequence / Autorotate

For interconnection of up to 16 units. Interconnection by means of a shielded twisted pair cable from interface board to interface board between units. This shall provide N+1 with one unit always in standby in case of duty unit failure. Standby unit shall be rotated over time. Changeover shall be set between 1-168 hours (1 hour – 1 week). In case of high temperature alarm standby unit shall run & revert to standby once temperature is corrected. In the group of up to 16 unit, any number can be running & any number can be set in standby.

Smoke Detector

A smoke detector shall be provided & mounted in the return air path to interface with the unit controls and generate an alarm.

Fire Detector

A fire detector shall be provided & mounted in the return air path to interface with the unit controls and generate an alarm.

Fire Stat

A fire stat shall be provided & mounted in the return air path within the unit to interface with the unit controls and indicate an alarm.

Water Detection – Point Type

Consists of a water detection module mounted in unit & point sensor which can be placed in unit or under the floor. Multiple point sensors can be placed in series with each other. A cable type water warning is also available.

RS 485 Communications Card

Serial interface card for Microprocessor board. For BMS setup. Can communicate on Delta 2 own Protocol & Modbus without an external Gateway.

BACnet over RS 485

Serial interface card for Microprocessor board. For BMS setup. Runs on BACnet protocol over RS 485. Final setup by BMS system integrator.

BACnet over TCP/IP

Serial interface card for Microprocessor board. For BMS setup. Runs on BACnet protocol over TCP/IP. Final setup by BMS system integrator.

SNMP over TCP/IP

Serial interface card for Microprocessor board. For BMS setup. Runs on SNMP protocol over TCP/IP. Final setup by BMS system integrator.

TREND Communication Card

Serial interface card for Microprocessor board. For BMS setup on TREND BMS. Final setup by TREND system integrator.

Condenser Factory Wired Disconnect

Factory wired disconnect fitted to condenser.

MCB and Contactor Condenser Control

MCB and contactor fitted in unit per condenser providing condenser on/off control interlocked with compressor.

MCB, Contactor and Pressure Switch Condenser Control

MCB, contactor and pressure switch fitted in unit per condenser fan providing condenser on/off based on condenser fan activated on pressure switch pressure signal.

LON Communication Card

Serial interface card for Microprocessor board. For BMS setup. Runs on LON FTT 10 protocol. Final setup by LON system integrator.

MCB, Contactor and Pressure Activated Fan Speed Control

MCB and contactor per condenser fan. Condenser fans are all 220V/1 Ph and unit has a single or dual input Johnson pressure activated fan speed control.

Condenser Fan Control with VSD

Uses a VSD to give a 0-10V proportional output to the condenser to maintain refrigerant head pressure control.

Graphic Display

An optional Graphical Terminal Unit is also available. This is a graphical display, LED Backlit with 132 x 64 pixel graphical resolution.

GENERAL ENGINEERING DETAILS

Model		06	12	18
Air Side Data				
Air Volume	m ³ /hr	1800	3600	5400
	m ³ /s	0.5	1.0	1.5
External Static Pressure ESP	Pa	75	75	75
No. of Fans	No.	1	1	1
Fan Motor	kW	0.55	1.10	1.50
Optional EC Plug Fan				
Quantity	No.	1	1	1
Fan Diameter	mm	350	400	450
Fan Motor	kW	1.23	1.40	1.45
Fan Absorbed Power	kW	0.2	0.5	0.9
Filter Data				
Downflow Filter Size	mm	495 x 535	495 x 535	495 x 695
Downflow Filter Quantity	No.	2	2	2
Upflow Filter Size	mm	775 x 300	775 x 300	775 x 460
Upflow Filter Quantity	No.	1	1	1
Filter Depth	mm	100	100	100
Filter Efficiency	-	G4	G4	G4
Water Side Data				
Control Valve Size	mm	20	25	25
Control Valve Kv	-	4.0	6.3	6.3
Chilled Water F&R Pipe Size	mm	22	28	28
Cooling Coil Data				
Coil Face Area – DX and C. Water	m ²	0.4	0.6	0.6
Coil Rows	No.	4	4	4
Coil Drain Connection BSPF	inch	1	1	1
Air Cooled Units				
Discharge Line Pipe Size	mm	16	16	16
Liquid Line Pipe Size	mm	12	12	12
Condenser Conns. Inlet/Outlet 30°C	mm	22/16	22/16	28/22
Condenser Conns. Inlet/Outlet 35°C	mm	22/16	28/22	28/22
Condenser Conns. Inlet/Outlet 40°C	mm	22/16	28/22	35/28
Condenser Conns. Inlet/Outlet 45°C	mm	22/16	35/28	35/28
Condenser Conns. Inlet/Outlet 50°C	mm	28/22	35/28	35/28
Scroll Compressor – 50Hz	-	ZR34	ZR61	ZR81
Scroll Compressor – 60Hz	-	ZR28	ZR48	ZR72
Compressor Quantity	No.	1	1	1
Noise Data				
Free field SPL @ 3m	dBA	52	55	57
Optional Humidifier Data				
Capacity	kg/hr	2	2	3
Inlet Connection BSPM	inch	1	1	1
Drain Connection BSPM	inch	1	1	1
Water Feed Pressure	Bar	1-10	1-10	1-10
Water Feed Electrical Conductivity	μS	400 – 800	400 – 800	400 – 800
French Degrees Water Hardness	-	15-30	15-30	15-30
Optional Electric Reheat Data				
Capacity - 400V/3Ph/50Hz	kW	7.5	9.6	9.6
Capacity - 220V/3Ph/60Hz	kW	7.5	9.6	9.6
Capacity - 380V/3Ph/60Hz	kW	6.8	8.7	8.7
Capacity - 460V/3Ph/60Hz	kW	10.0	12.8	12.8
No. of Stages	No.	2	2	2

Notes:

1. Indoor unit free field SPL dBA levels are measured at 3m.
2. For correct installation pipe sizes refer to refrigerant and water pipe sizing tables.

AIR COOLED SYSTEM SCHEMATIC

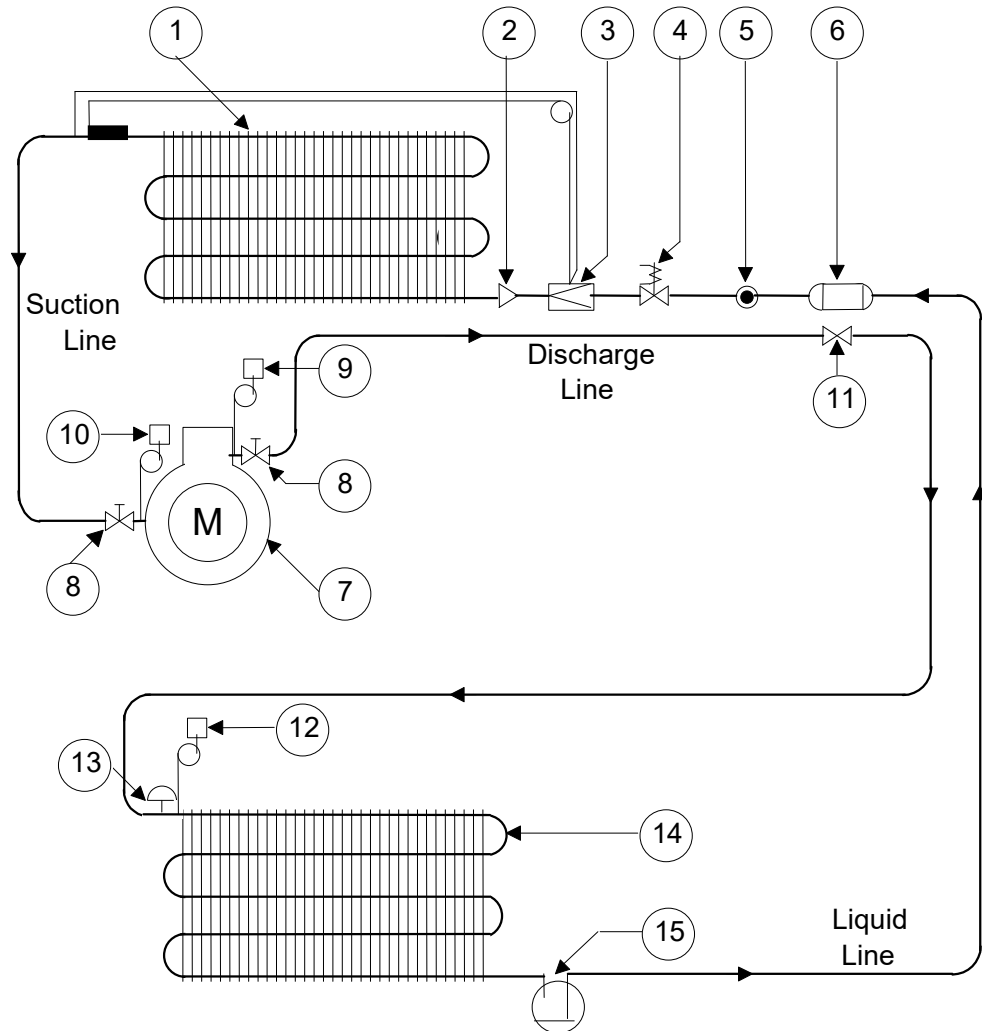

System Components

1. Evaporator Coil.
2. Liquid Distributor.
3. Thermostatic Expansion Valve (externally equalized).
4. Liquid Line Solenoid Valve (optional).
5. Liquid Sight Glass (including moisture indicator).
6. Filter Drier.
7. Compressor.
8. Compressor Service Valves.
9. High Pressure Switch (manual reset).
10. Low Pressure Switch (automatic reset).
11. Check Valve (See Note).
12. Fan speed Controller (pressure operated head pressure control, if fitted).
13. Pressure relief Valve (See Note).
14. Air Cooled Condenser.
15. Liquid Receiver (See Note).

Note:

1. Items 11, 13 and 15 are supplied by others and field fitted by others.

CHILLED WATER SYSTEM SCHEMATIC

3 Way Valve System

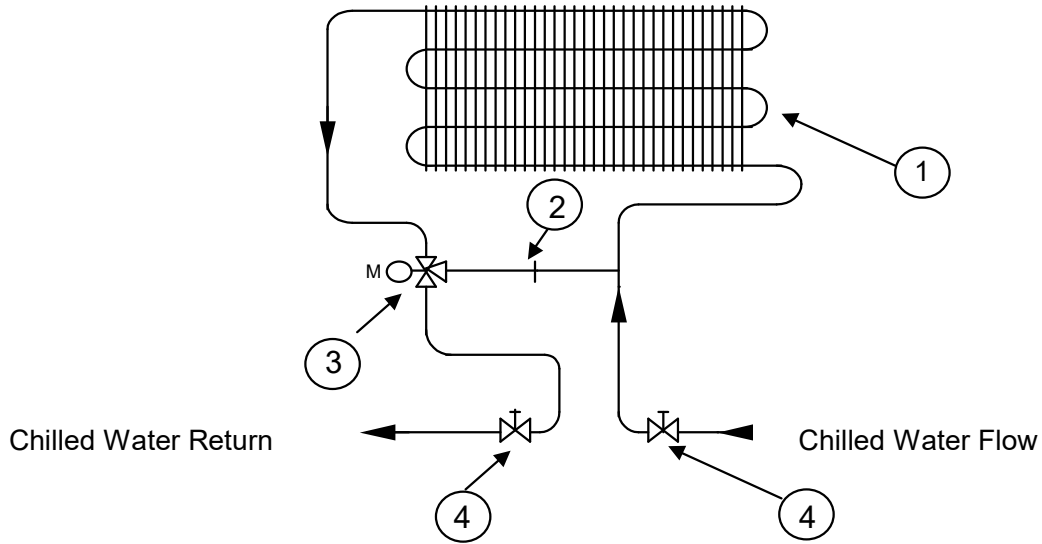

2 Way Valve System

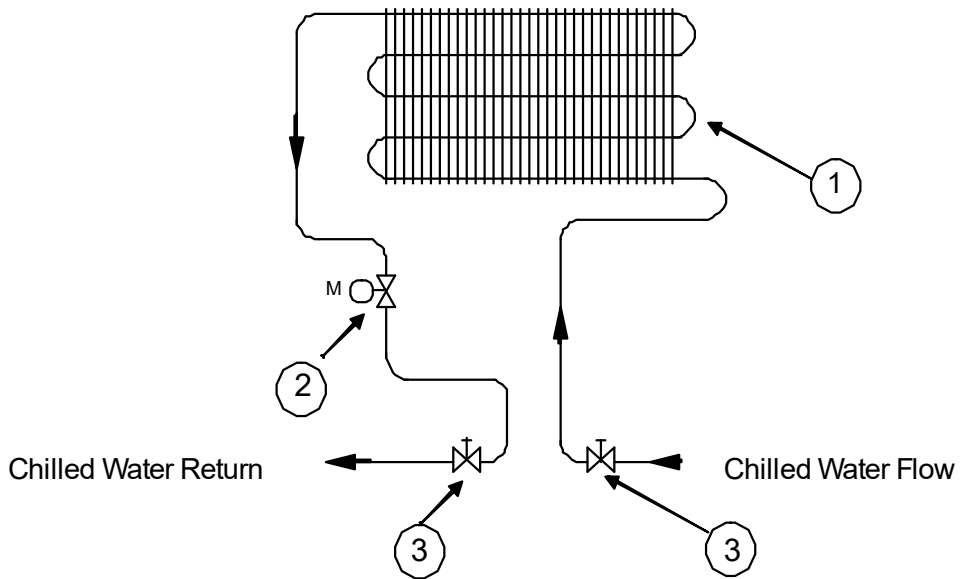

	3 Way Valve System	2 Way Valve System
1	Chilled Water Coil	Chilled Water Coil
2	Balancing Orifice	2 Way Modulating Valve
3	3 Way Modulating Valve	Isolating Valves
4	Isolating Valves	

Note: Isolating valves are field fitted by others.

AIR COOLED UNITS – COOLING CAPACITIES 50Hz

Model		06	12	18
Air On: 22°C, 45% RH				
Total Capacity	kW	7.2	13.0	17.4
Sensible Capacity	kW	6.8	12.3	16.3
Air On: 22°C, 50% RH				
Total Capacity	kW	7.2	13.0	17.4
Sensible Capacity	kW	6.6	11.9	15.8
Air On: 24°C, 45% RH				
Total Capacity	kW	7.5	13.6	18.1
Sensible Capacity	kW	6.8	12.1	16.3
Air On: 24°C, 50% RH				
Total Capacity	kW	7.5	13.6	18.1
Sensible Capacity	kW	6.6	11.9	16.0
Scroll Compressor	-	ZR34	ZR61	ZR81
Compressor Input Power	kW	2.3	4.0	5.3
Airflow	m ³ /s	0.5	1.0	1.5
No. of Fans	No.	1	1	1
Fan Motor	kW	0.55	1.10	1.50
No. of Motors	No.	1	1	1
Electric Reheat	kW	6.0	6.0	9.6
No. of Steps	No.	2	2	2
Humidifier Capacity	kg/hr	2	2	3
Humidifier Power	kW	1.5	1.5	2.2

AIR COOLED UNITS - COOLING CAPACITIES 60Hz

Model		06	12	18
Air On: 22°C, 45% RH				
Total Capacity	kW	7.3	12.6	18.4
Sensible Capacity	kW	6.9	11.9	17.3
Air On: 22°C, 50% RH				
Total Capacity	kW	7.3	12.6	18.4
Sensible Capacity	kW	6.7	11.5	16.7
Air On: 24°C, 45% RH				
Total Capacity	kW	7.6	13.1	19.1
Sensible Capacity	kW	6.9	11.6	17.2
Air On: 24°C, 50% RH				
Total Capacity	kW	7.6	13.1	19.1
Sensible Capacity	kW	6.7	11.5	16.9
Scroll Compressor	-	ZR28	ZR48	ZR72
Compressor Input Power	kW	2.4	3.8	5.6
Airflow	m ³ /s	1.5	1.0	1.5
No. of Fans	No.	1	1	1
Fan Motor	kW	0.55	1.10	1.50
No. of Motors	No.	1	1	1
Electric Reheat	kW	8.0	8.0	12.8
No. of Steps	No.	2	2	2
Humidifier Capacity	kg/hr	2	2	3
Humidifier Power	kW	1.5	1.5	2.9

Notes:

1. Capacities are based on R407C refrigerant.
2. For capacities at other conditions, please refer to the product selection program.
3. Units are also available for R134A applications, please contact the factory.
4. For R410A, please refer to the R410A catalogue or product selection program.
5. Cooling performances are gross. For nett capacities please deduct motor power as outlined on general engineering details page.

CHILLED WATER UNITS – COOLING CAPACITIES 50/60Hz

Model		06	12	18
Air On: 22°C, 45% RH				
Total Capacity	kW	7.0	12.2	18.3
Sensible Capacity	kW	7.0	12.1	18.3
S.H.R.	-	1.00	0.99	1.00
Chilled Water Flow	l/s	0.3	0.5	0.7
Unit Pressure Drop	kPa	16	21	49
Air On: 22°C, 50% RH				
Total Capacity	kW	7.0	12.2	18.3
Sensible Capacity	kW	6.4	12.1	18.3
S.H.R.	-	0.91	1.00	1.00
Chilled Water Flow	l/s	0.3	0.5	0.7
Unit Pressure Drop	kPa	16	21	49
Air On: 24°C, 45% RH				
Total Capacity	kW	8.2	14.2	21.4
Sensible Capacity	kW	7.5	14.1	21.3
S.H.R.	-	0.91	0.99	1.00
Chilled Water Flow	l/s	0.3	0.6	0.8
Unit Pressure Drop	kPa	20	27	60
Air On: 24°C, 50% RH				
Total Capacity	kW	7.0	14.2	21.4
Sensible Capacity	kW	6.5	12.7	18.8
S.H.R.	-	0.93	0.89	0.88
Chilled Water Flow	l/s	0.3	0.6	0.8
Unit Pressure Drop	kPa	16	27	60
Airflow	m ³ /s	0.5	1.0	1.5
No. of Fans	No.	1	1	1
Fan Motor	kW	0.55	1.10	1.50
No. of Motors	No.	1	1	1
Electric Reheat	kW	6.0	6.0	9.6
No. of Steps	No.	2	2	2
Humidifier Capacity	kg/hr	2	2	3
Humidifier Power	kW	1.5	1.5	2.2

Notes:

1. Capacities are based on a 6°C chilled water coil entering temperature & the tabulated flow rate.
2. Cooling performances are gross. For nett capacities please deduct motor power as outlined on general engineering details page.
3. For cooling performance at other conditions, please refer to the product selection program.
4. Electric reheat capacity is for 400V/3Ph/50Hz. For other voltages, see P11.

ELECTRICAL DETAILS – AIR COOLED UNITS
400V/3PH/50Hz

Model	06	12	18
Controls FLA	1.0	1.0	1.0
Fans FLA	1.5	2.7	3.6
Reheat FLA	8.7	8.7	13.9
Humidifier FLA	2.2	2.2	3.2
Scroll Compressor FLA	4.4	7.3	10.1
Condenser FLA 30°C	3.0	3.0	3.0
Condenser FLA 35°C	3.0	3.0	3.0
Condenser FLA 40°C	3.0	3.0	6.0
Condenser FLA 45°C	3.0	6.0	6.0
Condenser FLA 50°C	3.0	6.0	9.0
Max Unit FLA - Cooling only	9.9	17.0	23.7
Max Fuse FLA	15.0	30.0	35.0
Max Unit FLA - Cooling & Dehumidification	18.6	25.7	37.6
Max Fuse FLA	30.0	40.0	50.0
Max Unit FLA - Heating and Humidification	13.4	14.6	21.7
Max Fuse FLA	20.0	20.0	30.0

220V/3PH/60Hz

Model	06	12	18
Controls FLA	1.0	1.0	1.0
Fans FLA	2.7	4.9	6.6
Reheat FLA	15.8	15.8	25.3
Humidifier FLA	4.0	4.0	5.8
Scroll Compressor FLA	7.2	12.4	16.6
Condenser FLA 30°C	3.9	3.9	3.9
Condenser FLA 35°C	3.9	3.9	3.9
Condenser FLA 40°C	3.9	3.9	7.8
Condenser FLA 45°C	3.9	7.8	7.8
Condenser FLA 50°C	3.9	7.8	11.7
Max Unit FLA - Cooling only	14.8	26.1	35.9
Max Fuse FLA	25.0	45.0	55.0
Max Unit FLA - Cooling & Dehumidification	30.6	41.9	61.2
Max Fuse FLA	45.0	65.0	80.0
Max Unit FLA - Heating and Humidification	23.5	25.7	38.7
Max Fuse FLA	35.0	35.0	50.0

Notes:

1. FLA = Full Load Amps.
2. Unit maximum FLA is the total of the components, which operate during maximum electrical load conditions.
3. Max FLA of cooling only unit: FLA = Controls + Fans + Compressor + Condenser.
4. Max FLA of unit with reheat in dehumidification: FLA = Controls + Fans + Reheat + Compressor + Condenser.
5. Max FLA of units with heating & humidifiers: FLA = Controls + Fans + Reheat + Humidifier.
6. Max Fuse is the recommended value of the unit overcurrent protection device.

ELECTRICAL DETAILS – AIR COOLED UNITS
380V/3PH/60Hz

Model	06	12	18
Controls FLA	1.0	1.0	1.0
Fans FLA	1.6	2.9	3.8
Reheat FLA	8.2	8.2	13.2
Humidifier FLA	2.3	2.3	3.4
Scroll Compressor FLA	3.6	6.2	8.3
Condenser FLA 30°C	3.9	3.9	3.9
Condenser FLA 35°C	3.9	3.9	3.9
Condenser FLA 40°C	3.9	3.9	7.8
Condenser FLA 45°C	3.9	7.8	7.8
Condenser FLA 50°C	3.9	7.8	11.7
Max Unit FLA - Cooling only	10.1	17.9	24.8
Max Fuse FLA	15.0	30.0	35.0
Max Unit FLA - Cooling & Dehumidification	18.3	26.1	38.0
Max Fuse FLA	25.0	40.0	45.0
Max Unit FLA - Heating and Humidification	13.1	14.4	21.4
Max Fuse FLA	20.0	20.0	30.0

460V/3PH/60Hz

Model	06	12	18
Controls FLA	1.0	1.0	1.0
Fans FLA	1.3	2.3	3.1
Reheat FLA	10.1	10.1	16.1
Humidifier FLA	1.9	1.9	2.8
Scroll Compressor FLA	4.3	7.4	10.0
Condenser FLA 30°C	1.2	1.2	1.2
Condenser FLA 35°C	1.2	1.2	1.2
Condenser FLA 40°C	1.2	1.2	2.4
Condenser FLA 45°C	1.2	2.4	2.4
Condenser FLA 50°C	1.2	2.4	3.6
Max Unit FLA - Cooling only	7.8	12.9	17.3
Max Fuse FLA	15.0	25.0	30.0
Max Unit FLA - Cooling & Dehumidification	17.7	22.8	33.2
Max Fuse FLA	30.0	35.0	50.0
Max Unit FLA - Heating and Humidification	14.3	15.3	23.0
Max Fuse FLA	20.0	25.0	40.0

Notes:

1. FLA = Full Load Amps.
2. Unit maximum FLA is the total of the components, which operate during maximum electrical load conditions.
3. Max FLA of cooling only unit: FLA = Controls + Fans + Compressor + Condenser.
4. Max FLA of unit with reheat in dehumidification: FLA = Controls + Fans + Reheat + Compressor + Condenser.
5. Max FLA of units with heating & humidifiers: FLA = Controls + Fans + Reheat + Humidifier.
6. Max Fuse is the recommended value of the unit overcurrent protection device.

ELECTRICAL DETAILS – CHILLED WATER UNITS
400V/3PH/50Hz

Model	06	12	18
Controls FLA	1.0	1.0	1.0
Fans FLA	1.5	2.7	3.6
Reheat FLA	8.7	8.7	13.9
Humidifier FLA	2.2	2.2	3.2
Max Unit FLA - Cooling only	2.5	3.7	4.6
Max Fuse FLA	10.0	10.0	10.0
Max Unit FLA - Cooling & Dehumidification	11.2	12.4	18.5
Max Fuse FLA	20.0	20.0	25.0
Max Unit FLA - Heating and Humidification	13.4	14.6	21.7
Max Fuse FLA	20.0	20.0	30.0

220V/3PH/60Hz

Model	06	12	18
Controls FLA	1.0	1.0	1.0
Fans FLA	2.7	4.9	6.6
Reheat FLA	15.8	15.8	25.3
Humidifier FLA	4.0	4.0	5.8
Max Unit FLA - Cooling only	3.7	5.9	7.6
Max Fuse FLA	10.0	15.0	20.0
Max Unit FLA - Cooling & Dehumidification	19.5	21.7	32.9
Max Fuse FLA	35.0	30.0	45.0
Max Unit FLA - Heating and Humidification	23.5	25.7	38.7
Max Fuse FLA	30.0	35.0	50.0

Notes:

1. FLA = Full Load Amps.
2. Unit maximum FLA is the total of the components, which operate during maximum electrical load conditions.
3. Max FLA of cooling only unit: FLA = Controls + Fans.
4. Max FLA of unit with reheat in dehumidification: FLA = Controls + Fans + Reheat.
5. Max FLA of units with heating & humidifiers: FLA = Controls + Fans + Reheat + Humidifier.
6. Max Fuse is the recommended value of the unit overcurrent protection device.

ELECTRICAL DETAILS – CHILLED WATER UNITS
380V/3PH/60Hz

Model	06	12	18
Controls FLA	1.0	1.0	1.0
Fans FLA	1.6	2.8	3.8
Reheat FLA	8.2	8.2	13.2
Humidifier FLA	2.3	2.3	3.4
Max Unit FLA - Cooling only	2.6	3.8	4.8
Max Fuse FLA	10.0	10.0	10.0
Max Unit FLA - Cooling & Dehumidification	10.8	12.1	18.0
Max Fuse FLA	15.0	20.0	25.0
Max Unit FLA - Heating and Humidification	13.1	14.4	21.4
Max Fuse FLA	20.0	20.0	30.0

460V/3PH/60Hz

Model	06	12	18
Controls FLA	1.0	1.0	1.0
Fans FLA	1.3	2.3	3.1
Reheat FLA	10.1	10.1	16.0
Humidifier FLA	1.9	1.9	2.8
Max Unit FLA - Cooling only	2.3	3.3	4.1
Max Fuse FLA	10.0	10.0	10.0
Max Unit FLA - Cooling & Dehumidification	12.4	13.4	20.1
Max Fuse FLA	20.0	20.0	25.0
Max Unit FLA - Heating and Humidification	14.3	15.3	22.9
Max Fuse FLA	20.0	20.0	30.0

Notes:

1. FLA = Full Load Amps.
2. Unit maximum FLA is the total of the components, which operate during maximum electrical load conditions.
3. Max FLA of cooling only unit: FLA = Controls + Fans.
4. Max FLA of unit with reheat in dehumidification: FLA = Controls + Fans + Reheat.
5. Max FLA of units with heating & humidifiers: FLA = Controls + Fans + Reheat + Humidifier.
6. Max Fuse is the recommended value of the unit overcurrent protection device.