

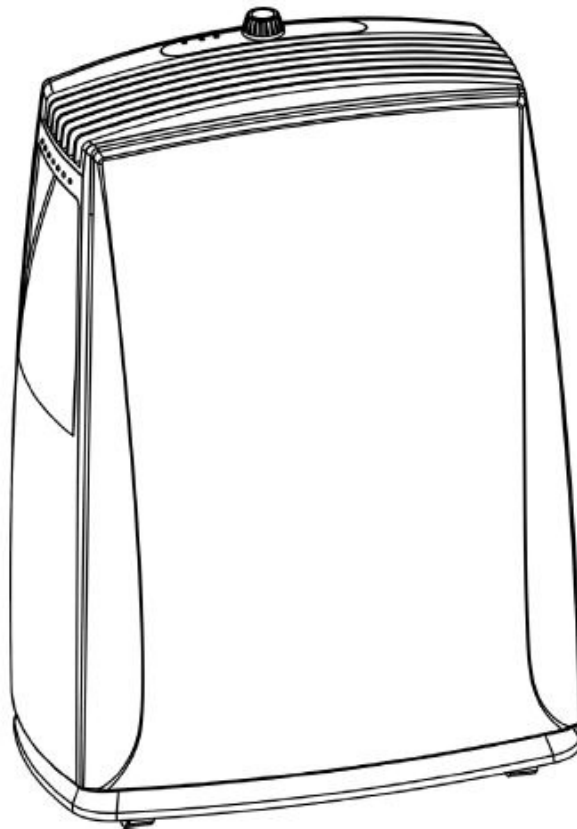

Installation and Operating Instructions

Model: FTE10	10L	Dehumidifier	
Model: FTE16	16L	Dehumidifier	
Model: FTE20	20L	Dehumidifier	08/52826/0 Issue 0



SAFETY INFORMATION

1. Please read the operating instructions carefully before using your dehumidifier for the first time and keep them in a safe place.
 2. Never immerse the appliance in water or other liquids.
 3. Never operate the appliance if a cable or connector has been damaged, after appliance malfunction or if the appliance was dropped or is otherwise damaged.
 4. Please ask a professional service agent to repair the product. Improper repair may cause danger to users.
 5. Never allow children to operate the appliance.
 6. Disconnect the appliance from mains power whenever it is not in use, before relocating it, and before cleaning.
 7. Operate the appliance only at the voltage specified on the rating label.
 8. This appliance is designed for household purposes (not commercial) only.
 9. **DO NOT COVER.** Never cover or obstruct in any way the outlet at the top of the dehumidifier or the air inlet slots at the rear of the dehumidifier.
 10. To prevent spillage, empty the water tank before relocating the appliance.
 11. Do not tip the appliance to any side as escaping water could damage the appliance. Only operate the product in a level upright position.
 12. This appliance is not intended for use by persons (including children) with reduced physical, sensory or mental capabilities, or lack of experience and knowledge, unless they have been given supervision or instruction concerning use of the appliance by a person responsible for their safety. Children should be supervised to ensure that they do not play with the appliance.
 13. When the supply cord is damaged, it must be replaced by the manufacturer, or a professional service agent only.
 14. Only operate this appliance with a minimum of 50cm clearance all around i.e. away from walls, furniture and overhanging objects such as curtains or a shelf.
 15. **When the unit stops, you have to wait for 3 minutes before you can restart the unit to protect the compressor from damage**
-

OPERATING INSTRUCTIONS

1. Control panel
2. Air outlet
3. Carry handle
4. Front panel

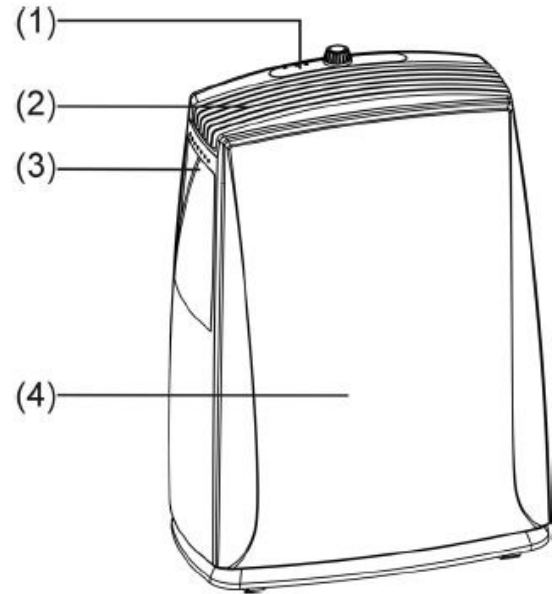

5. Air inlet
6. Water outlet tube (continuous use)
7. Water tank

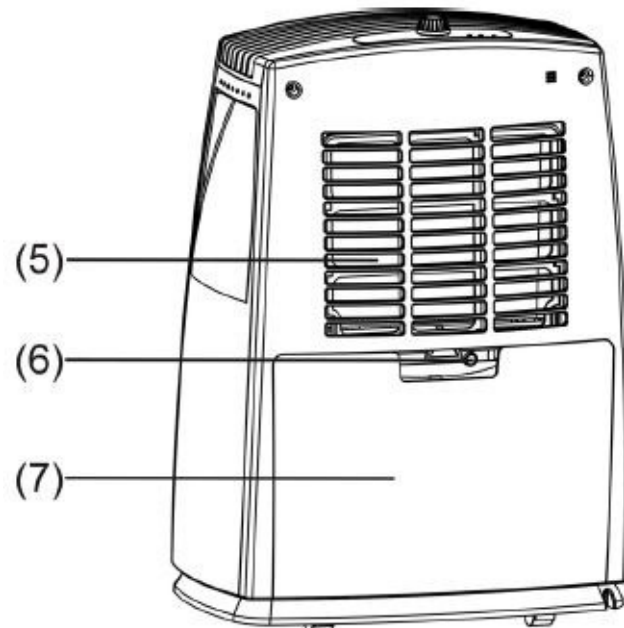

CONTROL PLATE DESCRIPTION

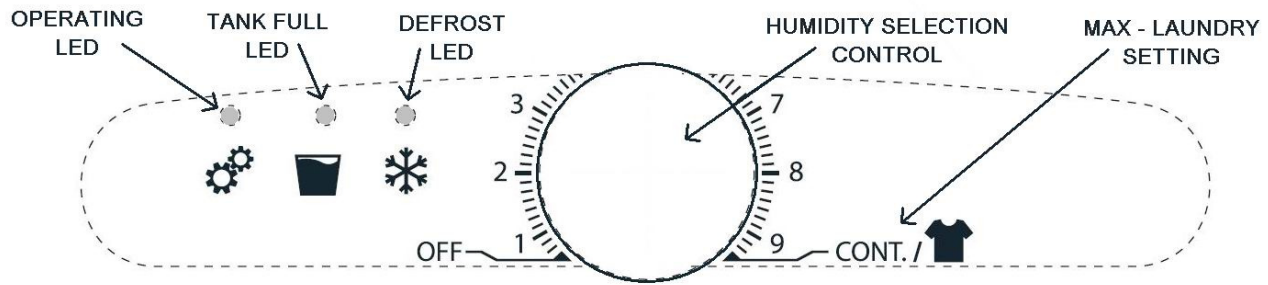

OPERATION INSTRUCTION

Starting the unit

Allow the unit to stand upright for 24hrs to let the compressor stabilize before first use or when transported.

1. Firstly, turn the humidity control switch to the “OFF” position.
2. Plug in the dehumidifier.
3. Turn on the humidity control switch (clockwise) and set it at the desired humidity level, please refer to table in point 4 below (e.g. position”4 = 60%).
4. For assistance in drying clothes in a laundry/ utility room, please select maximum dial position for continuous operation and maximum moisture removal.

Turning off the unit

1. Turn the humidity control switch fully anticlockwise to the “OFF” position and the power supply is cut off and the unit stops operating.
2. If the dehumidifier is not in use for a long time, please disconnect the power cord plug from the supply outlet.

NOTES AND PRECAUTIONS

1. The dehumidifier will not operate if the humidity dial is set lower than the ambient humidity e.g. room humidity 40% and dial setting 2 or 4. In other words the higher the humidistat dial setting e.g. position 8 the dehumidifier will attempt to dry the ambient humidity to 20% (RH) relative humidity.
2. When the water tank is full an automatic float switch shuts down the product and the tank full LED illuminates. Remove the water storage tank and empty its contents, carefully replace the empty water tank back in position, the unit will now automatically restart operating.

3. The following table indicates the approximate relative humidity settings against its related position number on the humidity control switch:

CONTROL SWITCH POSITION NO.	APPROXIMATE HUMIDITY SETTING
Cont. 	Continuous running
8	20 %
7	30 %
6	40 %
4	60 %
2	80 %

4. The ideal position is around position 6- approximately 40% relative humidity
5. The operational temperature range for this unit is 5-35°C. Please note the effectiveness of the product reduces as the ambient temperature reduces. For example in a room of 6°C- little if any moisture will be removed. The product works on the principal that it requires a high ambient temperature with warm air drawing over a very cold compressor creating water droplets.
6. Other than on the case of note 2 above, where the dehumidifier does not start, the operational light does not illuminate or the dehumidifier intermittently stops for unknown reasons, please check the plug and power supply for poor connection. If the plug and power supply are in good condition, wait for 10 minutes and restart the unit (it can take about 10 minutes for the unit to reset). If the unit still does not start after 10 minutes, please contact your retailer or the manufacturer for repair.
7. When the dehumidifier is in operation, the running compressor will produce heat. This is normal and may potentially raise the room temperature.
8. When the product is defrosting, the defrost LED will illuminate. The reason this happens is because the compressor gets very cold to maximize moisture removal. The defrost function protects the compressor from freezing up and avoid damage to the product.

DRAINAGE INSTRUCTION

Switch off before carrying out any of these operations and leave for 3 minutes before switching on again. The extracted water is collected by the water tank (set up as supplied), or can be set up to drain continuously using a PVC hose (not included) connected to a drain outlet, the drain point must be lower than the unit outlet (see details below).

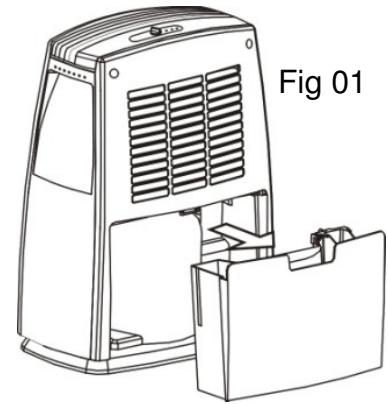

USE OF WATER TANK:

When the tank full LED illuminates the tank is full, the compressor and the fan will stop operation, please empty the water tank. Remove the water tank as per Fig 01 and empty it. Gently refit the water tank into the unit in its original position. Note, if the tank full LED remains on when the tank is emptied please remove and re-fit the tank to reset the light.

CONTINUOUS DRAINAGE

If you want to use this function, please pull out the water tank and plug a 9mm internal diameter water pipe onto the “Water out tube” (See Fig.02). Replace the water tank into the unit, the unit will now operate while discharging the extracted water through the free end of the fitted pipe, Note, you must ensure that the free end of the pipe is below the product outlet connection and that the drain point is likewise lower than the unit outlet.

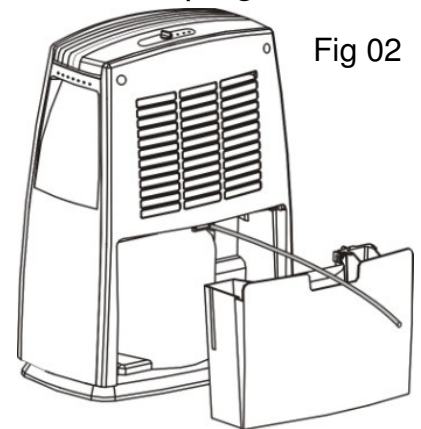

Filter Removal

- To remove the filter you must first remove the water tank as instructed above.
- The filter can then be removed from its slot by gripping the filter handle and sliding it down and out of the back of the appliance as indicated below.
- Every 2 weeks, remove the filter and clean it with warm water, below 40°C. Allow it to dry naturally and then replace by reversing the removal instruction above.

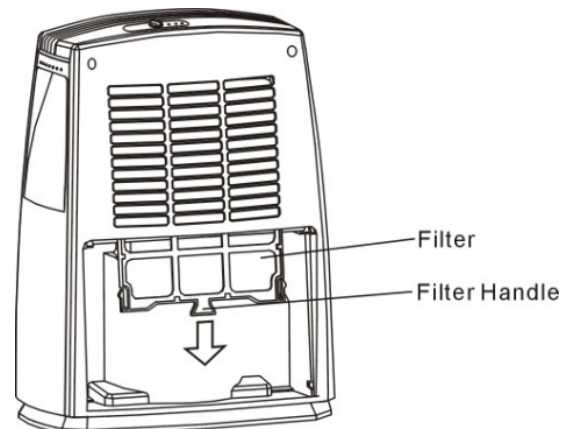

Care and Maintenance Instruction

1. To avoid the occurrence of vibration and noise the unit should not be operated while located on any soft or uneven surface.
2. Never insert any foreign objects into the unit through its air inlet or outlet to avoid hazard or unit failure.
3. During power off or when not in use for a long time, please disconnect the product from the mains.



4. For a better dehumidifying effect, the areas to the front, rear and above the unit should be clear and free from any obstacles which will block the air flow of the unit. Do not block any air inlet or outlet grilles – keep clear of hanging drapes, curtains and furnishings – **DO NOT COVER, as specified under safety information section a clearance of 50cm should be maintained all around the appliance when it is in use.**
5. Every 2 weeks, remove the air filter and clean it with warm water, below 40°C. Allow it to dry naturally and then replace by reversing the removal instruction above.

SPECIFICATIONS

MODEL \ SPECIFICATION	FTE10	FTE16	FTE20
POWER SUPPLY	220-240V~50Hz		
POWER INPUT	250W	410W	480W
RUNNING CURRENT	1.2A	2.1A	2.2A
WEIGHT	11.1Kg	13.3Kg	13.7Kg
MOISTURE REMOVAL (@ 30°C & RH 80%)	10 litre/day	16 litre/day	20 litre/day
DIMENSIONS (WxDxH)mm	W:365 x D:220 x H:500		
APPLICABLE TEMPERATURE	5°C - 35°C		
WATER TANK CAPACITY	2.3L		

(CE) N 842/2006:

R134A is a kind of fluorinated greenhouse gas covered by the Kyoto Protocol.

Its total global warming potential (GWP) is 1300



Recycling: For electrical products sold within the European Community. At the end of the electrical products useful life it should not be disposed of with household waste.

Please recycle where facilities exist.

Check with your Local Authority or retailer for recycling advice in your country.

After Sales Service:

Your product is guaranteed for one year from the date of purchase. Within this period, we undertake to repair or exchange this product free of charge provided it has been installed and operated in accordance with these instructions.

Your rights under this guarantee are additional to your statutory rights, which in turn are not affected by this guarantee. Should you require after sales information or assistance with this product please go to www.dimplex.co.uk or ring our helpdesk on 0844 879 3588 (UK) or 01 842 4833 (R.O.I.).

It would assist us if you can quote the model number, series, date of purchase and the nature of the fault at the time of your call. The customer services helpdesk will also be able to advise you should need to purchase any spares.

Please do not return any faulty product to us in the first instance as this may result in loss or damage and delay in providing you with a satisfactory service. Please retain your receipt as proof of purchase.

CE *This appliance complies with European Safety Standard EN60335-2-40, and European Electromagnetic Capability (EMC) EN55014-1, EN55014-2, EN61000-3-2 and EN61000-3-3. These cover the essential requirements of EEC Directives 2006/95/EC and 2004/108/EC.*

Dimplex	Customer Service UK:	0844 879 3588
Millbrook House	Fax:	0844 879 3582
Grange Drive	Email:	customer.service@gdcgroup.co.uk
Hedge End	Republic of Ireland:	01 842 4833
Southampton		
S030 2DF		

A division of GDC Group Ltd.
Website: www.gdcgroup.co.uk

© GDC Group Ltd.

All rights reserved. Material contained in this publication may not be reproduced in whole or in part without prior permission in writing of GDC Group Ltd.

