



*800.671.0641 info@dccspecialties.com

*Designed by Larry Maier

*Developed by DCC Specialties

*US Patent 7,810,435

New Exclusive Digitrax Configuration

New Timing Delay Features

New Programmable Power Up Status

New Auto Stop

For DCC Use Only

The PSX-AR Series

DCC Circuit Breaker & Auto Reverser

Integrated Turnout Control for Loop Automation

Intelligent, Solid State

Block Detection and Network Feed Back

Manual Rev P [10.17], Software Rev N [4.15]



The PSX-AR series is a product of years of research into problems dealing with false overloads that cause premature shut down of DCC Boosters and other Circuit Breakers. These false overloads are caused by large capacitors used in sound systems, decoders and lighted passenger cars. The overload appears as a short circuit until the capacitors are charged. The logic on the PSX-AR Series determines if the load is a true short or just an overload due to a discharged capacitor. A PSX-AR also has the logic & power to control switch machines at the throat of a reversing loop.

PSX-AR Versions Available: PSX-AR, PSX-ARFB [FeedBack], PSX-ARSC [SnapCoil] & PSX-ARSCFB [Snapcoil with Feedback]

- **Automatic Coordination of Auto Reverse and Circuit Breaker Tasks:** The PSX-AR is both an auto reverser and circuit breaker
- **Automates Reverse Loop Turnouts:** Integrated Stall Motor or Snap Coil Decoder, automatically lines up switch machines when the polarity is reversed. Switch machine can also be controlled with standard DCC Accessory Commands or push buttons.
- **All Solid State Operation:** Fast, solid state design, reliable quiet action, no clicks or sparks.
- **Adaptive Load Reset:** Electronically determines if the overload is a real short or due to excess capacitance in sound decoders or lighted passenger cars.
- **Special Digitrax Configuration Jumper:** Optimize functionality with all Digitrax systems
- **Programmable timing delay:** Use the PSX-AR as a fast blow or an adjustable slow blow fuse
- **Auto Stop with DCC Reset:** A photocell can be connected a PSX-AR input. Normally, covering the photocell will not cause any action. If the photocell is armed with a DCC command, the PSX-AR will turn off the next time the photocell is covered. A DCC command can restore the track power when desired.
- **Block Detection:** Either a photo cell or block current draw can be used to detect a train in a block and to trigger a Block Occupied output. The current trigger level is programmable.
- **Over Voltage Protection:** The PSX-AR incorporates a voltage suppression diode that limits voltage spikes on your layout.

- **Wide Range of Current Trip Setting:** *The breaker trip current can be adjusted over a range of 1.27 to 10.2 amperes. With additional cooling, the PSX-AR can handle up to 19.1 amperes. Trip current values are selected by setting a CV. Certain selected values can be set by placing jumpers on the board. Default trip current is about 4 amperes, which will work correctly for most layouts.*
- **Very Low Voltage Drop:** *Total breaker on resistance is less than 0.060 ohms, so the PSX-AR has a very low voltage drop even at high currents. Better than detectors that use a diode voltage drop.*
- **Manual or Automatic Reset:** *Automatic reset: Breaker tries to reset every 2 seconds. The reset delay can be set to a different value by changing a CV. Manual reset: Once the breaker trips, it remains off, ensuring complete isolation of the faulty block. The breaker is reset either by a switch or by a DCC command.*
- **Power On/Off by DCC:** *Turn on/off output track power with your DCC Throttle!*
- **Programmable Power Up Status:** *When power is applied to the layout, the PSX-AR can be set to always turn on, always remain off [power on as needed by DCC command], or to use the power status present when the layout was last shut down.*
- **Outputs for LED Indicators:** *Remote LEDs can be added to monitor input/output power status.*
- **Network Feedback:** *Isolated outputs designed to provide Block Occupied, Block Shorted, and Power Status to a discrete interface for remote display or computer control. Will work with Digitrax LocoNet, NCE Cab Bus, ESU ECoS, and Lenz XpressNet interfaces.*
- **System Reset:** *CV63=42 sets all CVs and addresses to original factory values.*
- **Output for Audio Alert:** *An audible sounder can be added to the card to provide an audible alert if there is a short.*
- **No Power Supply Needed:** *The PSX-AR uses the track DCC to supply its operating power. It draws less than 0.04 amperes.*
- **Easy to install:** *Board size is 5.75 by 2.75 inches with 4 mounting holes sized for a #6 screw.*
- **Flash Programmable:** *The PSX-AR firmware can be updated as new features become available or if older units need to be matched to a recent purchase.*

Instruction Manual Contents

- A. Quick Start
- B. User Guidelines
- C. How to Determine Power Districts
- D. PSX-AR Wiring
- E. PSX-AR Reverse Section Examples
- F. Terminal Wiring Descriptions
- G. Terminal Functions
- H. PSX-AR Accessory Addresses
- I. Programming CV's & Values
- J. CV Settings
- K. Special Programming Instructions
- L. Add On Circuit for the PSX-AR
- M. DCC System Sequential Programming Instructions

PSX-AR Connections

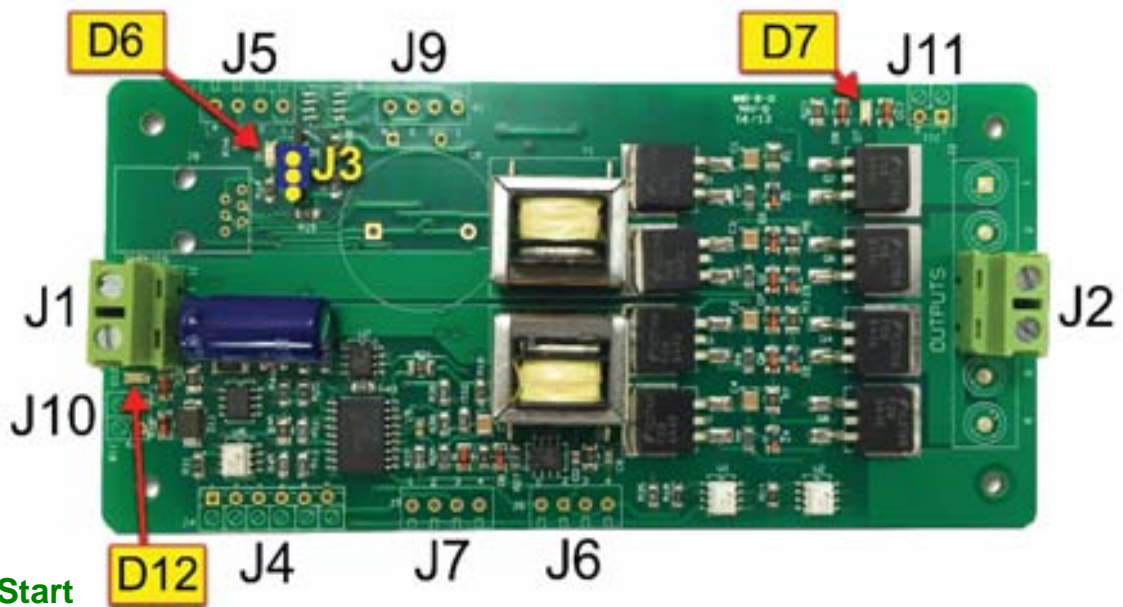

A. Quick Start

1. All connections involve two wire inputs from the DCC Booster [or Main DCC Power Bus] into a PSX-AR and two wire Outputs to the isolated reversing section or loop.
2. All PSX-AR Auto reverser/circuit breakers are ready to operate without programming
3. **Digitrax users should install the Digitrax Configuration Jumper wire from Terminal J7-3 to J7-4. Once installed, move the program jumper to cover pins J3.1 and J3.2 and apply DCC power to J1. Wait until D6 stops flashing, remove power, and restore the Program Jumper to cover J3-2 and J3-3.**
4. NCE Power Cab users must do one **[NOT BOTH]** of the following:
 - a. Install a jumper from J6-1 to J6-2
 - b. Program CV49=1
5. PSX-AR's are not compatible with Digitrax Analog Address [00] or any method that adjusts the "0" bit timing to allow operation of an analog engine.
6. Test the PSX-AR for functionality:
 - a. Turn on DCC power to the PSX-AR.
 - b. The PSX-AR should turn on with both D12 and D7 indicating power and D6 off.
 - c. Take a piece of wire and connect J1-1 to J2-3. Nothing should change.
 - d. Connect J1-1 to J2-4. The PSX-AR should reverse and D6 should be slowly flashing with D12 and D7 indicating power.
 - e. Connect J1-1 to J2-3. The PSX-AR should "unreverse".
 - f. D6 should stop flashing, but D12 and D7 should remain on.
 - g. Repeat this test except connect J1-2 to J2-4.
 - h. D12 and D7 should remain on, and D6 should be off.
 - i. Connect J1-2 to J2-3. The PSX-AR should reverse. D12 & D7 are on, with D6 slowly flashing.
 - j. Now connect J1-2 to J2-4.
 - k. The PSX-AR should again "unreverse" leaving D12 & D7 on and D6 off.
 - l. Verify D7 LED & D12 LED are ON, and the D6 LED is OFF.

Determining the software revision of your PSX-AR: The software revision of the PSX-AR is easily determined. Simply place the unit in the program mode and turn it on. D6 will flash the Morse code pattern of the software revision letter. The PSX-AR will flash long-short for revision N.

PSX-AR Terminal Wiring Diagram

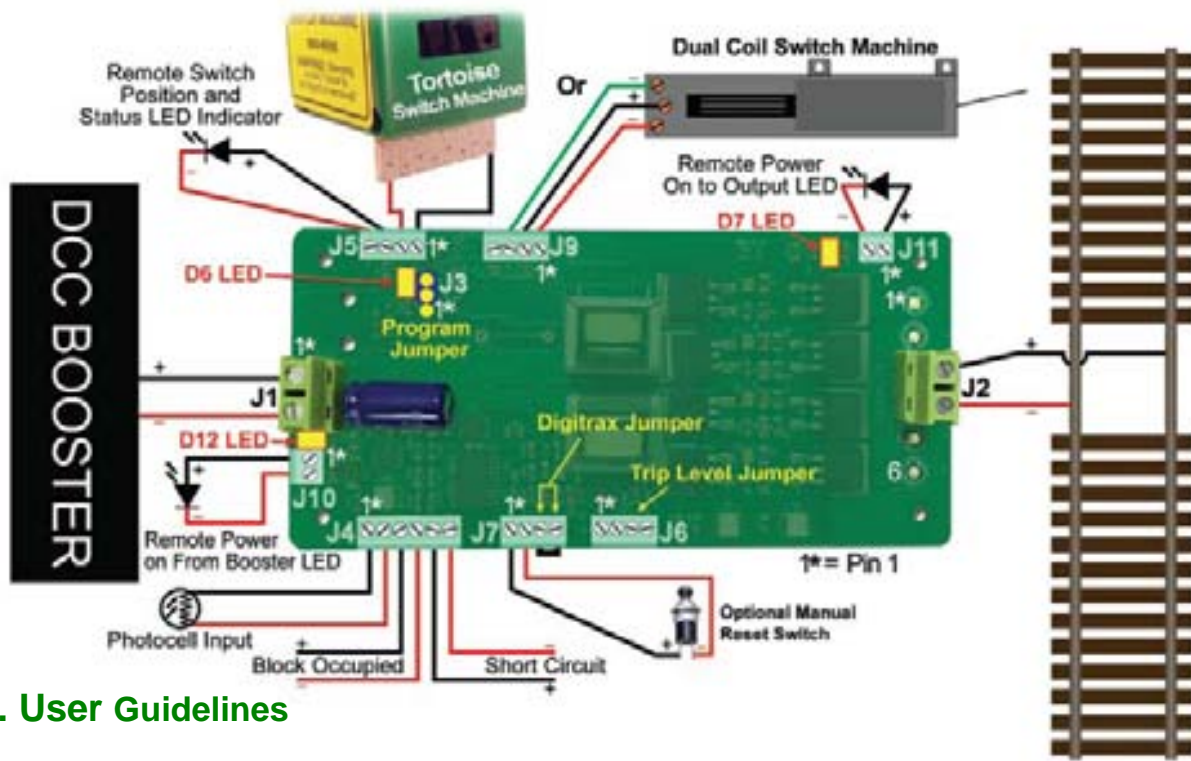

B. User Guidelines

1. Before wiring, ensure the Programming Jumper is on pins J3.2 & J3.3 to operate [Pin J3.1 is nearest the center of the PSX-AR circuit board]
2. Cut isolating gaps in the rails between PSX/PSX-AR zones; stagger gaps 0.75" [21mm]
3. If you are using both PSX circuit breakers and PSX-AR auto reversers on a layout and the locomotive hesitates when crossing a reverse gap, program the PSX controlling the track adjacent to the PSX-AR:
 - a. Program CV55=1 [enable delay]
 - b. Program CV65=128 [delay=16ms]. CV65 may be any value from 1 to 255. The delay in milliseconds is the CV65 value divided by 8. Ideally CV65 should be the smallest value that consistently works correctly. CV65=128 should work for most layouts.
4. Input & Output connectors J1 and J2 are designed for use with 12-22 AWG wire.
 - a. Turn screw on connector's counter-clockwise while looking at the connector opening
 - b. Make sure the wire clamp is at the bottom of the connector opening.
 - c. Insert the wire you are connecting and turn the connector screw clockwise to tighten.
5. If you are using a heavier bus wire such as 10 AWG, solder a short length of 12 or 14 AWG wire to your heavier bus to connect to the PSX-AR terminal.
6. We recommend rail drops to the track bus every 3-5 feet. Insufficient feeders can cause your track voltage to be significantly lower than your booster output voltage.
7. When wiring more than one PSX or PSX-AR [PSX-2, PSX-3 PSX-4, PSX-AR etc.] insure all input/output polarities are the same
8. The PSX-AR Circuit breaker is designed to operate by opening both of the two input leads when an overload is detected.
 - a. In "normal" polarity (D6 is not flashing), J1-1 is connected to J2-1, J2-3, J2-5 and J1-2 is connected to J2-2, J2-4, J2-6. In "reverse" polarity (D6 flashes slowly), J1-1 is connected to J2-2, J2-4, J2-6 and J1-2 is connected to J2-1, J2-3, J2-5.

- b. The reverse loop should NOT use a common rail wiring scheme. Both rails must be isolated from the rest of the layout for the PSX-AR to work properly.
 - c. If the PSX-AR breaker function activates, J1-1 and J1-2 are disconnected from ALL J2 connections.
9. Connect the two wires from the DCC Booster to the PSX-AR J1-1 & J1-2 INPUT terminal
10. When Power is applied to the PSX-AR, the D12 LED near the J1 Input and the D7 LED near the J2 Output should be on.
11. If the D6 LED near the J3 Programming Jumper is on solid, you may have a short between the two wires from the J2 Output or in the track section.
12. Test the PSX-AR installation prior to running a train:
- a. Observe your DCC booster is not shorted.
 - b. Use a suitable metal object to short the track.
 - c. The status LED D6 should come on and D7 near the output should be off.
 - d. Your booster should not trip during this test [D12 stays on].
13. If your booster does trip during this test [D12 goes off or flashes on and off], it may not be able to support automatic reset.
- a. Install the Manual Reset jumper [J7-1 to J7-2] and repeat the test. Your booster should now remain on [D12 stays lit].
 - b. With the Manual Reset jumper in place, you can reset the PSX-AR by sending an accessory ON command [check your system manual for correct key sequence] to accessory address 2042 [997 if you installed the Digitrax Jumper]
 - c. With the Manual Rest jumper in place, you can also reset the PSX-AR by connecting a Normally Closed momentary push button in series with the Manual Reset jumper. Pressing the button will reset the PSX-AR.

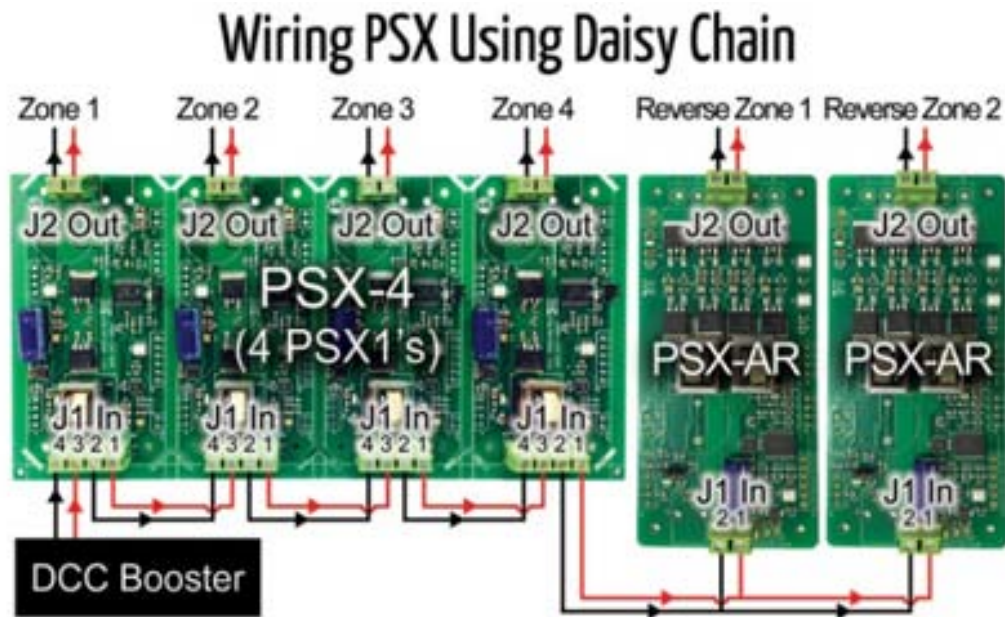

C. How to Determine Power Districts

There are two types of power districts: Single power district per booster or multiple power districts on a single booster. In either case, you want a PSX or PSX-AR protecting each power district. If you have a single booster for a power district, you still want a PSX-1 protecting that district. The reason is that the protective circuitry in the booster is designed to protect the

booster, NOT your \$1000 fully lit, full sound, decoder equipped, fully detailed scale model. The PSX series IS designed to protect your models. For the multiple power district per booster, you want to use a PSX-2, PSX-3, or PSX 4. Each PSX feeds a district, and the inputs of the PSX are daisy chained together to a single booster.

Probably the best way to determine where to place power districts is to take a look at the expected current draw [primarily locomotive motors which use power] for each operating location on the layout. For example, a busy yard might have several switchers, one or more trains on the arrival and departure tracks, another train or two passing the yard on the main, and maybe a peddler local working nearby industries. If some or all of these trains have more than one locomotive, you could have 10 to 15 current drawing units all competing for power in a fairly small area. Assuming all the locomotives have efficient motors, this type of power requirement [amps] may be large enough to overload a DCC system powered from one 5 Amp booster. For example, if you have four PSX set to the default current, each PSX will trip at about 4 amperes. If each power district draws 3.5 amperes, that is a total of 14 amperes. None of the PSX will trip, but your 5 amp booster will certainly shut down. You can solve this by lowering the trip current on each of the four PSX, getting a booster with a higher current rating, or splitting the four districts on one booster to two districts on each of two boosters.

Multi-Booster Power District Schematic

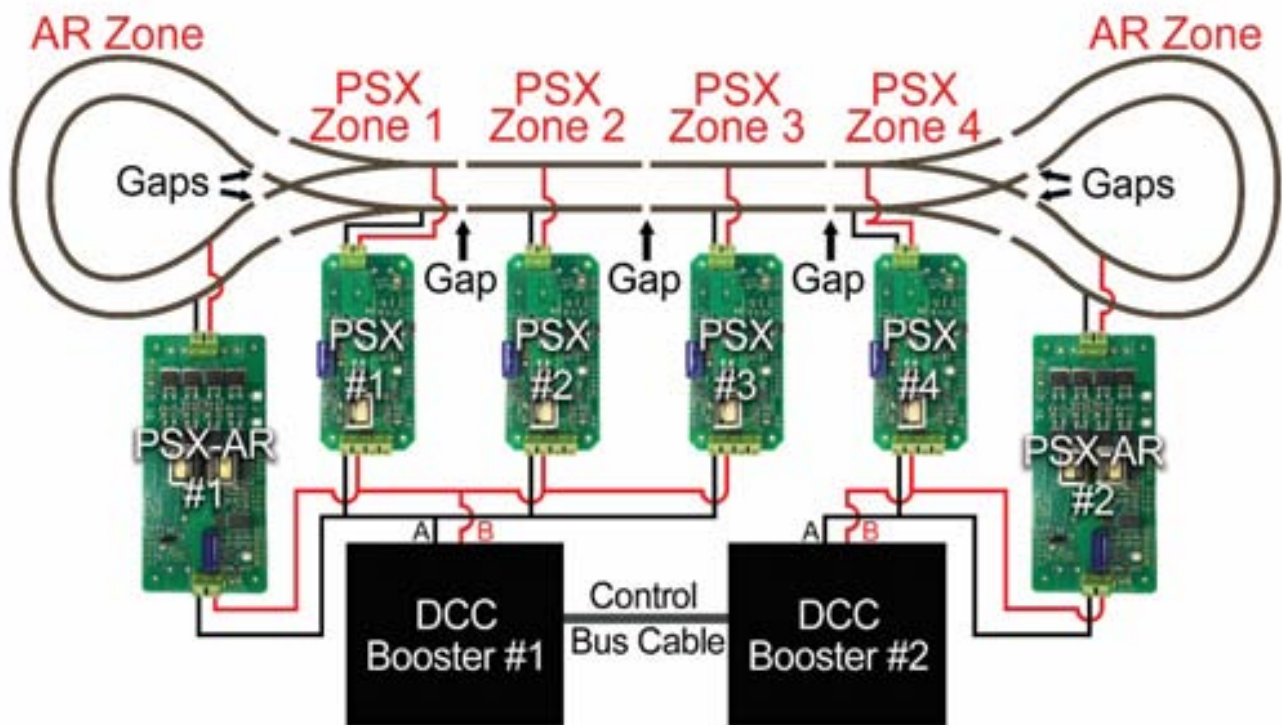

Based on our experience, a typical HO scale 5 Amp system can support up to 10 operators using a 12-14 AWG bus and 20 AWG feeders. Many users overestimate the amount of Booster power needed. Try using the PSX Series first. If your DCC Booster overloads from excess current draw, you need to add an extra DCC Booster to support the concentration of trains in this location. By dividing a layout into power districts in this manner, and using a combination of boosters and circuit breakers, you can make the most efficient use of available power on any mid-size or large-size layout.

Another thing you want to keep in mind while designing power districts is how each district is used. In a yard area, for example, there is a higher risk of derailments occurring with their associated shorts. You might want to isolate this area into a separate district so that a short in the yard will not stop mainline operations.

D. PSX-AR Wiring

Wire to the PSX-AR should be heavy enough to carry the current efficiently. The size of wire depends on your scale. Too much resistance in the wire or rails can result in faulty short sensing, voltage drop and poor performance. At a minimum, we recommend the following stranded gauge wires to prevent potential problems:

- N Scale 18 AWG bus, 22 AWG rail feeders
- HO Scale 14 AWG bus, 20 AWG rail feeders
- O Scale 12 AWG bus, 16 AWG rail feeders

We recommend using stranded pair wire such as speaker or lamp cord wire for bus wiring. If you're using two individual stranded wires, make sure to twist the wire 4 to 6 times every foot. You can make your own twisted pair wire by placing two ends of the wire in a drill bit, chuck the drill tight, and then turn on while you or something else holds the other end.

E. PSX-AR Reverse Section Examples

Reverse Section Notes

- 1) Make sure isolating rail gaps are offset by 0.75" [21mm] and the AR Zone is longer than your longest train
- 2) If your train is longer than your reverse block and has metal wheels:
 - a) You may need to cut additional gaps in the **REVERSE SECTION**.
 - b) Simply cut another set of gaps at **BOTH ENDS** of the reverse sections inside of the original gaps.
 - c) The distance between new gaps and original gaps should be longer than the wheelbase of any metal truck.

PSX Reverse Loop Schematic

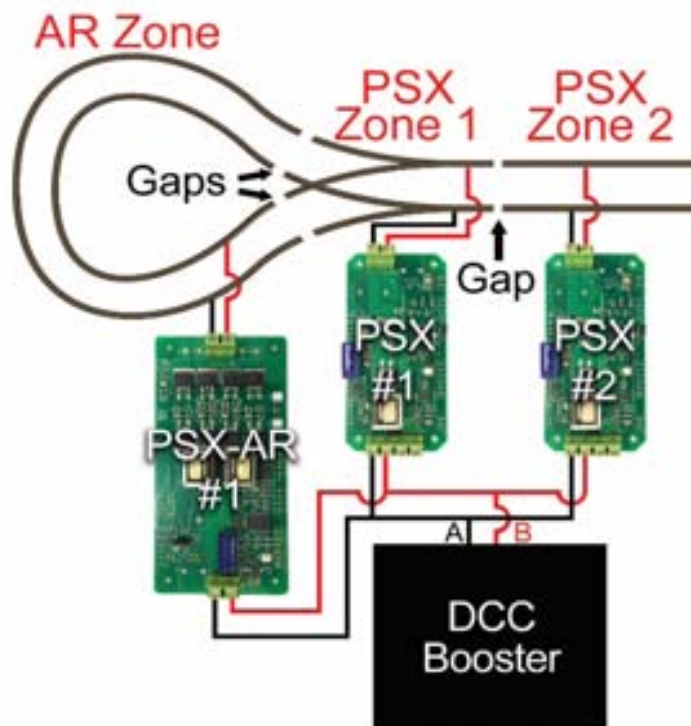

PSX-AR On A Wye "Leg"

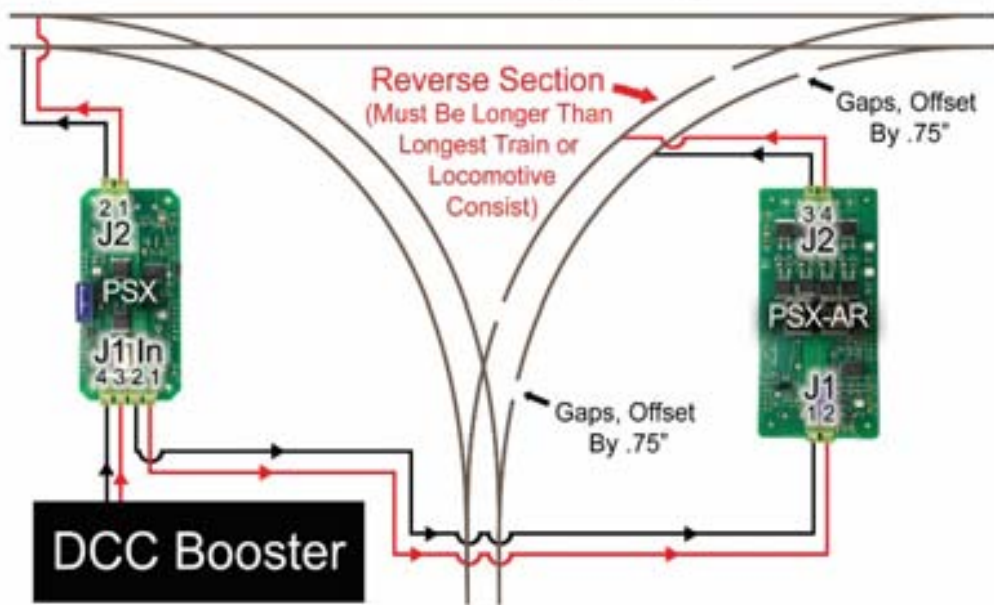

PSX-AR On A Wye "Tail"

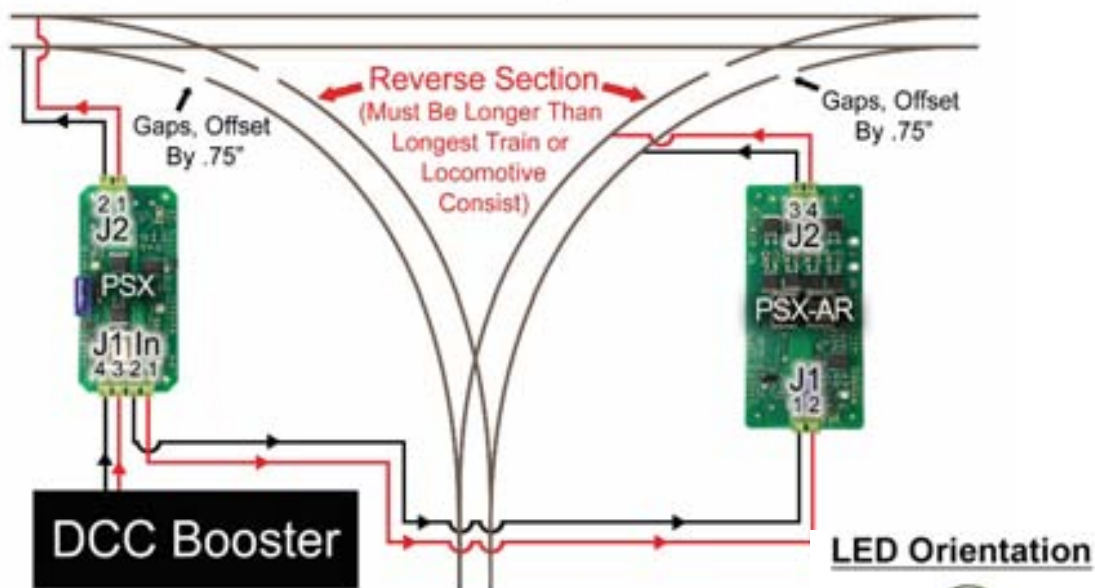

F. Terminal Wiring Descriptions

J1 Input Power Connector

- J1-1 DCC Power Input A [from DCC Booster]
- J1-2 DCC Power Input B [from DCC Booster]

J2 Output Power Connector

- J2-1,3,5 Switched DCC Power Output A ["normal" polarity]
- J2-2,4,6 Switched DCC Power Output B ["normal" polarity]
- J2-1,3,5 Switched DCC Power Output B ["reverse" polarity]
- J2-2,4,6 Switched DCC Power Output A ["reverse" polarity]

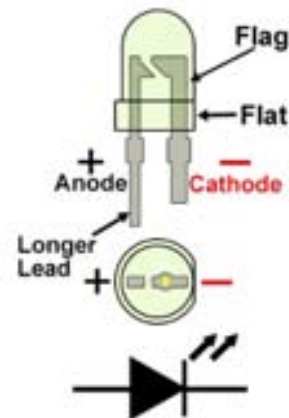

PSX-AR Terminal Wiring Diagram

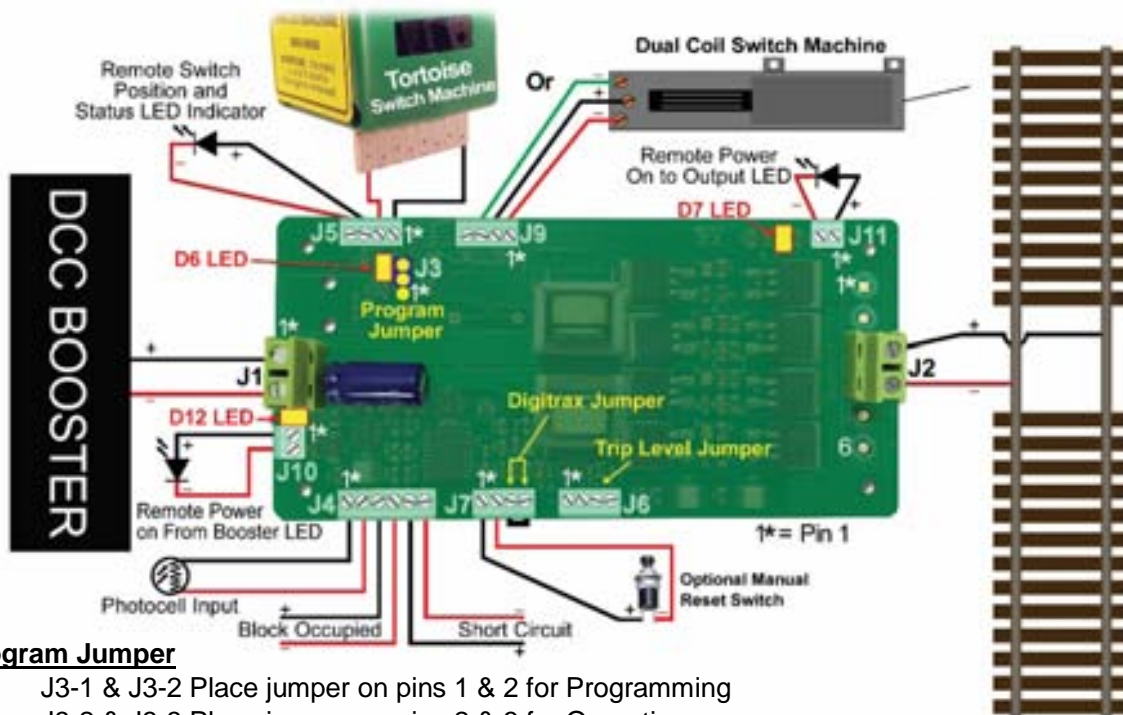

J3 Program Jumper

- J3-1 & J3-2 Place jumper on pins 1 & 2 for Programming
- J3-2 & J3-3 Place jumper on pins 2 & 3 for Operations

J4 Block Occupancy

- J4-1 Photo Sensor Input [active]
- J4-2 Photo Sensor Input [return]
- J4-3 + [collector] Block Occupied Output [Network Feedback]
- J4-4 - [emitter] Block Occupied Output [Network Feedback]
- J4-5 + [collector] Block Shorted Output [Network Feedback]
- J4-6 - [emitter] Block Shorted Output [Network Feedback]

J5 Status Outputs [Remote]

- J5-1 To Tortoise Pin 1 or 8 *
 - J5-2 To Tortoise Pin 8 or 1 *
 - J5-3 + [anode] Remote Status LED [copies D6]
 - J5-4 - [cathode] Remote Status LED [copies D6]
- *Select such that gaps closest to aligned point direction are in phase*

J6 Trip Current Settings by Jumpers

- See Table to the right and also CV 49
- **Set trip current using either Jumpers or CV 49: NOT BOTH**

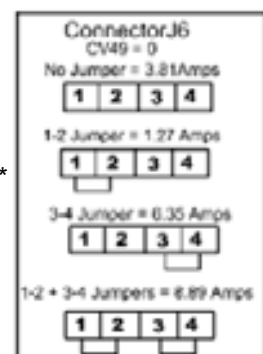

J7 Auto/Manual Reset & Digitrax Loconet Special Configuration

- J7-1 to J7-2 with No Jumper: Auto Reset [default]
- J7-1 to J7-2 with Jumper: Manual Reset [open to reset] The user can install a normally closed switch in series with the jumper. Open the switch to reset the PSX-AR or send an accessory ON command to the PSX-AR on-off command address [see Section B item 12]
- **J7-3 to J7-4 with Jumper: Digitrax Loconet Special Configuration [Section A item 3]**

*****PSX-AR LED Outputs do not require resistors*****

J9 Dual Coil Switch Machine Option

- J9-1 Switch Coil Output [-]
- J9-2 Switch Common [+]
- J9-3 Switch Coil Output [-]
- J9-4 Switch Common [+]
- Either J9-2 or J9-4 may be used for the common of three wire switch machines

J10 DCC Power In Remote LED Indicator Output

- J10-1 + [anode] DCC Power In LED Remote [copies D12]
- J10-2 - [cathode] DCC Power In LED Remote [copies D12]

J11 Track Power On Remote LED Indicator Output

- J11-1 + [anode] Track On LED Remote [copies D7]
- J11-2 - [cathode] Track On LED Remote [copies D7]

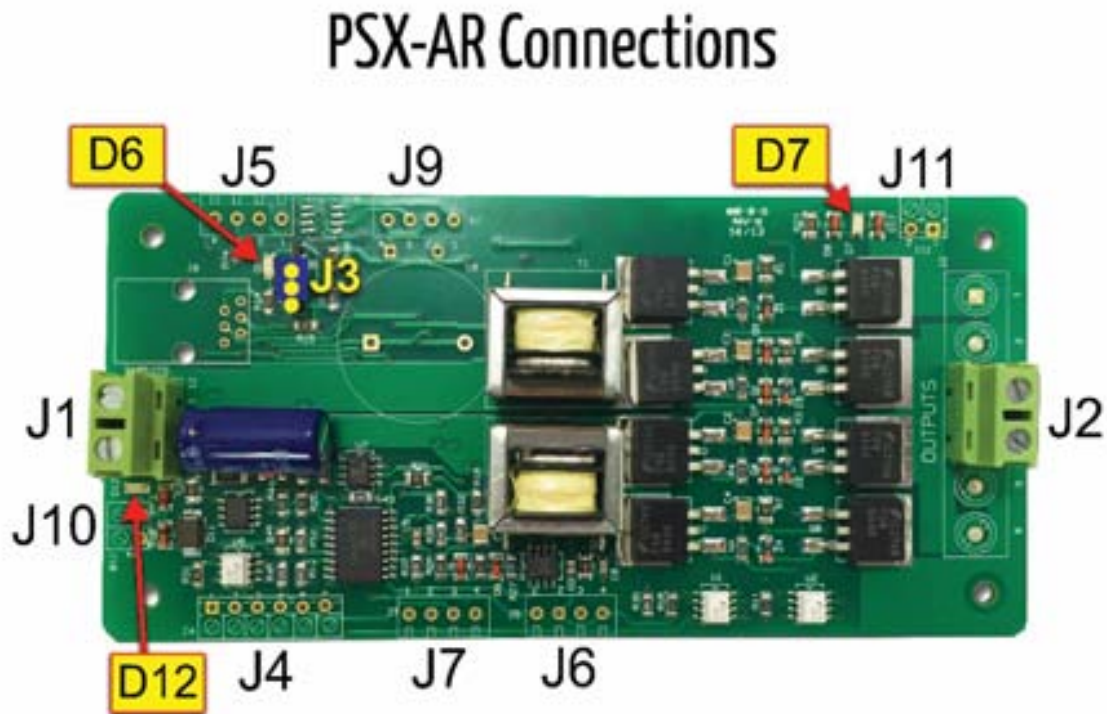

G. Terminal Functions

J1 – DCC power input connections from the DCC booster.

J2 – DCC track power output terminal from the PSX-AR circuit breaker to the track.

J3 – Programming & Operation jumper. Normal operating configuration is when the jumper is in the J3-2 to J3-3 position. Place the jumper in the J3-1 to J3-2 position to enter programming mode.

J4-1 and J4-2 are the inputs for the photocell detector used for the stopping function and/or the block occupancy function. Note: Be sure there is sufficient light above the cell to trigger the circuit. The photocell sensitivity is calibrated to the local light intensity each time the photocell is armed. You can order the photocell sensor through Tony’s Train Exchange.

J4-3 [+] and J4-4 [-] are open if the block is not occupied and are connected together [up to 5 mA] if the block is occupied. This is an optically isolated open collector transistor and provides no power.

J4-5 [+] and J4-6 [-] are connected together [up to 5 mA] when the breaker has detected a short circuit and open during normal operation. This is an optically isolated open collector transistor and provides no power.

J5-1 [+] and J5-2 [-] are connected to pins 1 and 8 of a Tortoise switch machine. The reverser will align the Tortoise with the direction of the reverser. Pin 1 and 8 on the Tortoise may need to be swapped to make sure the switch point direction aligns with the polarity of the reverser. The reverse loop gap which is encountered first after passing through the switch should be in phase. A bi-color LED can be used in series with the Tortoise to indicate the switch position.

J5-3 [+] and J5-4 [-] Are for a remote status LED. The LED is connected directly to the terminals. No resistor is required.

- Off = Normal
- Blinking = Reversed
- Steady On = Short Circuit

J6 – Sets the current trip level. When CV49=00 [default] the trip current is 3.81 amperes if no jumpers are installed. If J6-2 is connected to J6-1 and J6-4 to J6-3 is open, then the current trip is 1.27 amperes. This is the correct setting for the NCE Power Cab. If J6-4 is connected to J6-3 and J6-2 to J6-1 is open, then the current trip is 6.35 amperes. If J6-4 is connected to J6-3 and J6-2 is connected to J6-1, then the current trip is 8.89 amperes.

J7-1 and J7-2 are the auto/manual reset input. If the connections are open, the breaker will automatically try to reset every two seconds [default]. If the terminals are connected together with a SPST toggle switch or N/C momentary push button switch, then the breaker will remain off after a short until the connection from J7-1 to J7-2 is momentarily opened or an accessory ON command is sent to the PSX-AR on-off accessory address [see Section B item 12].

J7-4 to J7-3 is the **Digitrax Loconet Special Configuration** jumper. By installing this connection, all aspects of the PSX-AR series are optimized to operate with Digitrax equipment. This includes the DCS50, DCS51, DCS100, DCS200, DCS 210, DCS240 and the associated booster units. On Digitrax systems, setting OPSW #18 to “CLOSED” will extend the short circuit shutdown to 0.5 seconds. This will help prevent the booster from shutting down during a short circuit. See Section A item 3 for correct use of this jumper. Note: this jumper DOES NOT affect the PSX-AR trip current. Depending on your device, you may also need to set the trip current by adjusting CV49 or installing jumpers in J6.

J8 is the software upgrade interface and not for consumer use.

J10-1 [+] and J10-2 [-] Remote LED indicator showing DCC power is available to PSX-AR.

J11-1 [+] and J1 1-2 [-] Remote LED indicator showing track DCC power status [on or off].

*****PSX-AR LED Outputs do not require resistors*****

H. PSX-AR Accessory Addresses

Specific DCC Systems need to follow specific programming sequences to reliably program a PSX-AR. See Section M for specific system instruction

Digitrax users: Install the Digitrax Loconet Configuration Jumper wire from Terminal J7-3 to J7-4 [see Section A item 3]

The easiest way to address a PSX-AR circuit breaker is at your work bench. The PSX-AR's addresses are SET by moving the program jumper as described below and issuing an accessory command like operating an accessory by using your DCC Throttle.

There are three [3] accessory addresses used by the PSX-AR. A command to the first address turns the PSX-AR output ON (1) or OFF (0). A command to the second address arms the photo cell detector. If no photo cell is connected, this command will turn the PSX-AR OFF. A command to the third address will allow you to control the position of the switch connected to the PSX-AR.

H.1 Setting the Three Accessory Addresses:

1. Turn off power to the PSX-AR
2. Place the J3 programming jumper on pins J3-1 & J3-2
3. Connect the DCC track power output of your DCC system to pins J1-1 and J1-2.
4. Turn power on to the PSX-AR.
5. The next accessory command issued by the DCC system will be stored as the first address [track on/off].
6. Key in the first address you want to use and press either the ON or OFF accessory command [or the appropriate key for your throttle – see the chart below]
7. By default, the PSX-AR will store the next two sequential addresses as the second and third PSX-AR address.
8. If you don't want to use these values, then key in an address that you want to use for the second address and issue an ON or OFF command.
9. Repeat for the third address you want to use.
10. Each time you press the ON or OFF key with a new address, you should see D6 flash indicating that the PSX-AR received the address and stored it.
11. When finished with the addresses you want to use, turn off DCC power to the PSX-AR.
12. Put the program jumper back to J3-2 and J3-3 unless you are going to program CV settings.
13. Note the default addresses are 2042, 2043, and 2044 unless you followed the Digitrax jumper directions in which case the defaults are 997, 998, and 999 (software Rev N or higher). If these are acceptable, you do not need to program the address.

For all systems, whenever you enter an address or CV value, you should see D6 flash. This indicates the PSX-AR has received the information, stored it, and verified the stored data match the data you sent.

Reference Chart for the Three Accessory Commands

Function	Default Address	New
Control Switch	2044 [999]	?
Arm Photocell	2043 [998]	?
Track Power On/Off	2042 [997]	?

System	Normal [Clear]	Thrown
Digitrax	c or Closed	t or Thrown
Lenz	+	-
MRC	ON	OFF
NCE	Normal/ON/ 1	Reverse/OFF/ 2

The table above shows how the DCC Manufacturers identify the **Normal [Clear]** and/or the **Thrown** Route to operate accessories.

H.2 Using Accessory Addresses:

1. **The first PSX-AR accessory address** [Default address 2042, 997 for Digitrax] lets you use DCC Accessory Commands to turn the PSX-AR DCC output on and off.
2. **The second PSX-AR accessory address** [Default address 2043, 998 for Digitrax] is used to arm the photocell circuit.
 - a. If the photocell is not armed [power on condition] then covering or uncovering the photocell has no effect.
 - b. Sending an ON accessory command to the second address [default 2043, 998 for Digitrax] arms the photocell.
 - c. When armed, the ambient light level at the photocell is measured.
 - d. If the ambient light level drops significantly [e.g. a train covers the photocell], the output of the PSX-AR is turned off removing power from the track.
 - e. Once the output has turned off, the photocell reverts to being unarmed until the next arming command.
 - f. Track power can be restored by issuing an accessory ON command to the first PSX-AR accessory address.
 - g. This is designed to allow you to stop a train at a known point on a hidden staging track. As the train enters the staging [or other] track, you issue the photocell arming command. When the train just covers the photocell, the PSX-AR will turn off and the train will stop exactly at the photocell.
 - h. In order to leave the staging area, simply issue an accessory ON command to the first PSX-AR accessory address. The PSX-AR will apply power to the track and the train can be moved. Since the photocell is now disarmed, you can move the train over the cell without affecting the power status.
3. **Advanced staging control:** The photocell can act as a block occupied detector & a staging control at the same time.
 - a. Connect a photocell between J4-1 and J4-2.
 - b. Connect the cathode [-] of an LED to J4-2 and the anode [+] to J4-4.
 - c. Install a wire between J4-3 and J6-2.
 - d. Set CV50=1 and CV66=0.
 - e. This will set the photocell to also control the block detector output [which has the LED connected now] and will have the PSX-AR power up with the output OFF so staging areas don't normally draw current.
 - f. When you arm the photocell with these settings, the LED will slowly flash indicating it is waiting for a train.

- g. When a train enters the block and covers the photocell, track power will turn off and the LED will change from flashing to steady indicating a train is now in the block.
- h. Further, the PSX-AR has stored the last photocell calibration values, so you can shut down the layout with a train in the staging, and the PSX-AR will remember to show block occupied the next time you power on.
- i. As in the basic photocell control, send an accessory ON command to the first PSX-AR accessory address and the block power will turn on. The occupied LED will remain on until the end of the train clears the photocell while the train is leaving the block.

PSX-AR Terminal Wiring Diagram

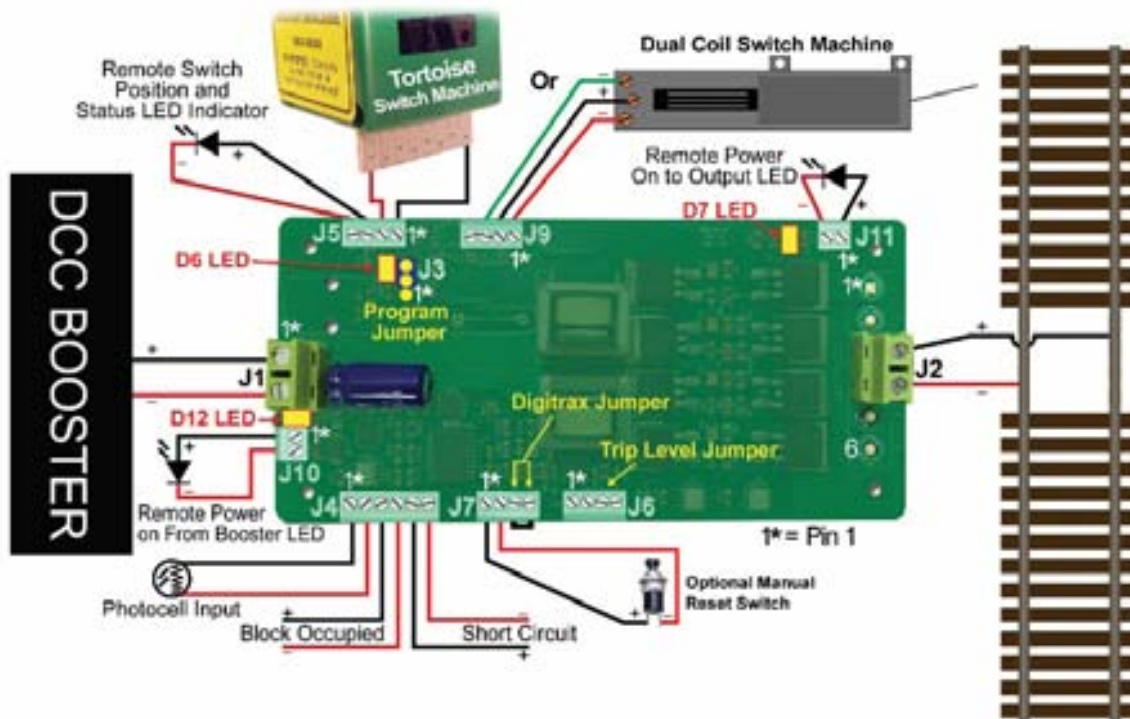

4. [The third PSX-AR accessory address](#) [Default address 2044, 999 for Digitrax] is used to control the switch connected to either J5 (Tortoise) or J9 (snap coil). Sending an accessory command to this address will operate the switch points. It is important to get the switch position and the PSX-AR output phase correctly synchronized, otherwise the PSX-AR will throw the points under your train as it enters the reverse loop. Send an accessory Clear command to the PSX-AR. If the points move to the Throw position, then reverse either J5-1 and J5-2 (for Tortoise) or J9-1 and J9-3 (snap coil). With the points in the Clear position, enter the reverse loop through the Clear direction to the closest gap at the end of the reverse loop. The DCC voltage in the reverse loop and the adjoining “normal” track should be in phase. If you have a meter, measure the voltage across the insulating gap between “normal” and reverse loop sections on the SAME rail. If you read close to zero volts, the two sections are in phase. If you do not have a meter, you can use a 14 volt grain-of-wheat engine headlight bulb or similar incandescent lamp. Again, connect it across the gap on the SAME rail. If the lamp remains off, the two sections are in phase. If you read a voltage roughly equal to the DCC track voltage or if the lamp illuminates, then the sections are out of phase. In this case, exchange the J2-3 and J2-4 output wires. You should now have the two sections in phase and are set to run a train through the reverse loop.

I. Programming CV's & Values: Optional/Not Required!

Specific DCC Systems need to follow specific programming sequences to reliably program a PSX-AR. See Section M for specific system instruction

The easiest way to program PSX-AR circuit breakers is at your work bench. Programming CV values is done using the Programming On Main [POM] function. Refer to your DCC system manual for specific directions on how to perform Program On Main functions.

1. Turn off power to the PSX-AR
2. Place the J3 programming jumper on pins J3-1 & J3-2
3. Connect the DCC track power output of your DCC system to pins J1-4 and J1-3.
4. Turn power on to the PSX-AR.
5. Go into Program On Main mode [POM] for your particular DCC system. See Section K.
6. Enter any address NOT in use on the layout. The PSX-AR does NOT use this address, but the POM function requires an address.
7. Enter the CV number followed by the value. The small red LED [D6] on the PSX-AR will blink each time a command is accepted and the CV value is stored correctly in the CV.
8. If you make a mistake, don't worry, just go back and program the CV to the desired value.
9. If you are hopelessly lost, set CV63 to 42 and you can start over again with factory default values.
10. When done, turn power off.
11. Replace the program J3 jumper to pins 2-3.
12. Turn power to the PSX-AR off.

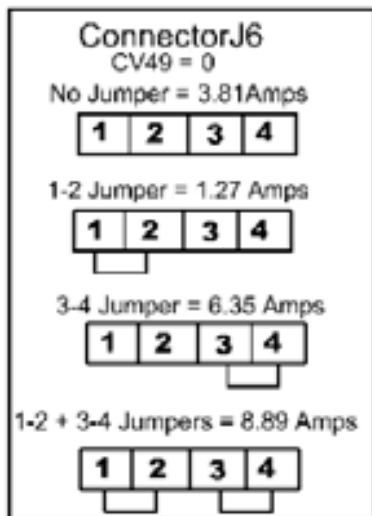

CV49	Trip Current [Amps]	Continued	
00	3.81 or Per Jumper Chart	CV	Trip Current
01	1.27	08	10.2
02	2.54	09	11.4*
03	3.81	10	12.7*
04	5.08	11	14.0*
05	6.35	12	15.2*
06	7.62	13	16.5*
07	8.89	14	17.8*
		15	19.1*

***Caution:** continuous operations at a value higher than CV49=08, [10.2 amps] without the addition of heat sinks to the output transistors may overheat or damage the PSX-AR. Heat sinks are available from DCC Specialties. PSX-AR's can also be ordered with heat sinks installed.

For all systems, whenever you enter an address or CV value, you should see D6 flash. This indicates the PSX-AR has received the information, stored it, and verified the stored data match the data you sent.

J. CV Settings

CV49 – sets the current trip value. If CV49=0, then the Trip Current jumpers on J6 are enabled. **Remember to use either the Jumpers or the CV settings, NOT BOTH!**

Low Power System Trip Current Settings:

- For the Digitrax Zephyr [DCS50 & DCS51], setting values of CV49=01 or CV49=02 is OK.
- The NCE Power Cab should use a value of CV49=01.
- Most 5 amp boosters should be happy with CV49=03 or CV49=04.
- The default current is 3.81Amps.

CV50 is the block detection source selection.

- CV50=0 selects block current as the parameter to activate the Block Occupied [J4-3 and J4-4] output. See CV54.
- CV50=1 will use the photocell to activate the Block Occupied output when the photocell is covered. Note the photocell is self-calibrating & will adjust itself to the ambient light level at the time the unit is turned on. [See CV66 and CV67].
- The CV50 default is 0.

CV52 is the power on phase of the PSX-AR output

- CV52=0 Selects “normal” phase at power on [output in phase with input]
- CV52=1 selects “reverse” phase at power on [output is out of phase with input].
- 0 is the default value for CV52

CV53 Digitrax configuration enable

- CV53=0 uses standard parameters [Default value].
- Any other value: the PSX uses algorithms designed to work most effectively with Digitrax equipment. Installing the Digitrax jumper J7-3 to J7-4 automatically sets CV53=1.

CV54 sets the current level at which the PSX-AR turns on the Block Occupied output. This allows you to set a level above the leakage current on the track to prevent false indications.

- Valid CV54 values are 0 to 212 [4mA to 51mA].
- CV54 default is 0, this will turn the Block Occupied output on at 4mA block current
- Each increment [+1] of CV54 will increase the Block Occupied trip point by approximately 0.22mA

CV55 determines the time between the occurrence of an over current condition [e.g. short circuit] and the changing of the output polarity. After reversing, the PSX-AR checks that the reversal solved the short circuit condition. If it did not, then the circuit breaker function is initiated and the output turns off. Hence the CV55 value determines a delay in both the reversal time and the trip time.

- CV55=0. The PSX-AR trip time is equivalent to a fast blow fuse. The output will reverse in less than 1ms after the over current condition occurs.
- CV55=1 The PSX-AR will insert a delay between the time the over current condition occurs and the output changes polarity. If the current drops below the trip current set point [CV49] during the delay time, the output will not reverse or turn off. This is equivalent to the behavior of a slow blow fuse.
- If CV55=1, the length of the delay is determined by CV65.
- The CV55 default is 0 [see CV65 for default delay].

- If you have two reverse loops that touch each other, a train crossing the gap will cause both to reverse at the same time, which will preserve the short circuit and cause both to trip. In this case, select one of the PSX-ARs to be the “secondary”. Set CV55=1 in the secondary PSX-AR. Adjust CV65 [see also CV65 below] such that the secondary PSX-AR always waits for the other PSX-AR to reverse first. You may also need to adjust the delay time of any PSX breaker that is adjacent to the secondary PSX-AR. While a better design is to have a length of “normal” track longer than your longest engine between two reverse loops, this cannot always be accomplished.

CV57 determines the amount of time in seconds the Automatic Reset function will wait before trying to restore track power after an over current condition is detected and the PSX-AR has tripped.

- The CV57 default value is 2.
- If you notice that your booster shuts down after several automatic reset cycles, try increasing the time between resets.
- If increased reset time does not solve the problem, you may need to use the Manual Reset mode [see Section B, item 13].

CV63 initiates a PSX-AR Factory Reset.

- Using the Program On Main [**POM**] programming mode of your DCC system, set CV63=42.
- You will see D6 flash.
- After D6 flashes, all CVs and addresses are returned to their original factory values.
- The CV63 default is 0. Setting CV63=42 will not change the CV value, but it will reset the PSX-AR.

CV65 controls the length of delay enabled by CV55.

- Valid CV65 values are 1 to 255.
- The delay in milliseconds is the CV65 value divided by 8 [e.g. a value of 80 = 10ms delay].
- The ideal value for CV65 is the smallest value that still results in reliable layout operation.
- If you are experiencing nuisance trips, try increasing CV65 by 8 until the nuisance trips stop.
- A value of CV65=128 should work for almost all layout problems. Remember, the PSX-AR is supposed to turn off when it sees too much current. A “nuisance” trip is still an over current condition. Make sure the “nuisance” condition is acceptable before you increase the trip delay of the PSX-AR and hide a real layout issue.
- The CV65 default is 8 which will be an added delay of approximately 1ms. It is selected as the minimum delay to use in conjunction with a PSX-AR in a double reverse loop situation, although your layout may require more delay.

For all systems, whenever you enter an address or CV value, you should see D6 flash. This indicates the PSX-AR has received the information, stored it, and verified the stored data match the data you sent.

CV66 controls how the PSX-AR provides power to the track when the associated booster is turned on.

- CV66=0 The PSX-AR output will always be OFF after the booster power up. This is useful for staging and storage yards or similar layout sections where there is no point in using booster power for equipment that will not be running. When needed, the PSX-AR is turned ON by an Accessory Command.
 - If a photocell is connected and CV50=0, then the photocell will always be calibrated and disarmed. It will only control power output.
 - If a photocell is connected and CV50=1, the photocell is enabled to control both the PSX-AR power output and the PSX-AR Block Occupied output. With this option, the photocell remembers its calibration at booster shutdown so that the next power on session it will correctly identify if the block is occupied [photocell covered] or not [photocell uncovered]. The photocell is NOT calibrated and is disarmed
 - If CV50=1, Block Occupied will flash when the photocell is armed. It will become steady [on without flashing] when the photocell is covered and the PSX-AR output is switched OFF [stopping train over photocell; Block Occupied indicating OCCUPIED].
- CV66=1 The PSX-AR output will always be ON after the booster power up.
 - If a photocell is connected, it will always be calibrated and disarmed regardless of the value in CV50
- CV66=2 The PSX-AR output will assume the same state it was in when the connected booster was last turned off.
 - If the stored power down state is OFF, the PSX-AR will behave the same as if CV66=0
 - If the stored power down state is ON, the PSX-AR will behave the same as if CV66=1
- CV66 default is 1. The PSX-AR will always power up and the photocell [if present] will always calibrate and be disarmed.
- In the event that the photocell is calibrated while covered, it will mis-calibrate [it assumes it is uncovered]. In most cases, simply waiting until the next time the photocell is armed will solve the problem since it will perform a calibration before arming. If you want to calibrate the photocell but NOT arm it, send an accessory OFF command to the second PSX-AR address. Make sure the photocell is uncovered when you issue the command. This is useful if you are using the photocell for block occupancy detection.

CV67 is used to inhibit flashing of the Block Occupied output when the photocell is armed.

- If CV50=1 and CV66=0, the Block Occupied output will flash whenever the photocell is armed. The PSX-AR power output is on.
- The flashing can be inhibited by setting CV67=1. Any other value of CV67 will enable the flashing.
- CV67 default is 0 [flashing enabled].

Determining the software revision of your PSX-AR: The software revision of the PSX-AR is easily determined. Simply place the unit in the program mode and turn it on. D6 will flash the Morse code pattern of the software revision letter. The PSX-AR will flash long-short for revision N.

K. Special Programming Instructions

Specific DCC Systems need to follow specific programming sequences to reliably program a PSX-AR. See Section M for specific system instruction

All systems: Program CV's using POM. Do not use Program track or accessory programming.

Digitrax: Install the Digitrax Configuration Jumper wire from Terminal J7.3 to J7.4

By installing the Digitrax Configuration jumper connection, all aspects of the PSX-AR series are optimized to operate with Digitrax equipment. This includes the DCS50, DCS51, DCS100, DCS200, DCS210, DCS240 and the associated booster only units. As a result of these changes, it is recommended that any layout using Digitrax equipment should install this jumper. Note that the configuration jumper does NOT affect the trip current setting. You will still need to select the trip current you want to use.

When the J7-3 & J7-4 jumper is installed and the PSX-AR is placed in Program mode, the default addresses of the PSX-AR are automatically changed to allow the Digitrax system to access these functions directly:

- 997 [on/off – first address]
- 998 [photo cell arm – second address]
- 999 [switch control PSX-AR only – third address]

If the PSX-AR is reset [CV63=42], the default address will be 2042, 2043 & 2044. These addresses are not accessible to the Digitrax equipment. Under this condition it is necessary to:

1. Remove power from the PSX-AR while in Program mode
2. Re-apply the power in Program mode with the Digitrax Configuration jumper on pins J7-3 & J7-4
3. This will program the Digitrax default addresses again [997, 998, 999]

Note that if the J7-3 & J7-4 jumper is absent and the PSX-AR is placed in program mode, the 997, 998, & 999 sequence will be changed back to the normal default of 2042, 2043, & 2044. If the PSX-AR has been programmed to an address other than one of the two default address sequences, the presence or absence of the jumper will have no effect on the stored addresses.

At power up, Digitrax systems place several commands on the track bus intended for use by other Digitrax accessories. These signals appear to the PSX-AR as an accessory address. In order to prevent these addresses from incorrectly programming the PSX-AR, a PSX-AR will not accept a command to program an accessory address above 999 when the Digitrax Configuration Jumper is installed.

With the Digitrax Configuration Jumper installed, the PSX-AR uses a different turn on algorithm that enhances the ability of the Digitrax equipment to turn on multiple sound decoders without difficulty.

For all systems, whenever you enter an address or CV value, you should see D6 flash. This indicates the PSX-AR has received the information, stored it, and verified the stored data match the data you sent.

Lenz:

The Lenz system sends repeat accessory commands as long as you hold down the 1 or 4 command key. This ensures that the accessory decoder sees the message, but can result in the same address stored multiple times while programming a PSX-AR. The solution is simple:

1. Hold the 1 or 4 key down for only a short time.
2. Release the control key once you see the PSX-AR's D10 LED flash indicating an address has been stored.
3. If you see multiple flashes, you have stored the same address more than once.
4. Since the PSX-AR will flash D10 each time you send it an accessory address, you can easily get a feel for the timing involved.
5. In normal operating mode [not programming mode], select an accessory address that has not been programmed into the PSX-AR.
6. Send an accessory command to this address and hold down the 1 or 4 control key.
7. D10 will flash each time the command station repeats the accessory address. This will give you a feel of how long to hold the control key while you are programming to avoid storing multiple addresses.

L. Add On Circuits for the PSX-AR by Don Fiehmann

The PSX-AR reverser/circuit breaker has become a very popular way to control polarity in reverse loops and wyes. The PSX-AR also has many features that can be used when wired to a layout. Here is a simple control that can be easily added for more control using the PSX-AR.

- 1) **Pushbutton Control of Turnout:** This option gives control of both positions. We like simple solutions and this one qualifies for that category. Three pieces of wire and two push-button switches is all that is required. The way this works is the pushbutton switch puts a short between either of the rails of the loop and one of the rails feeding the loop. This causes the PXS-AR to instantly reverse the rail polarity and also throw the switch.

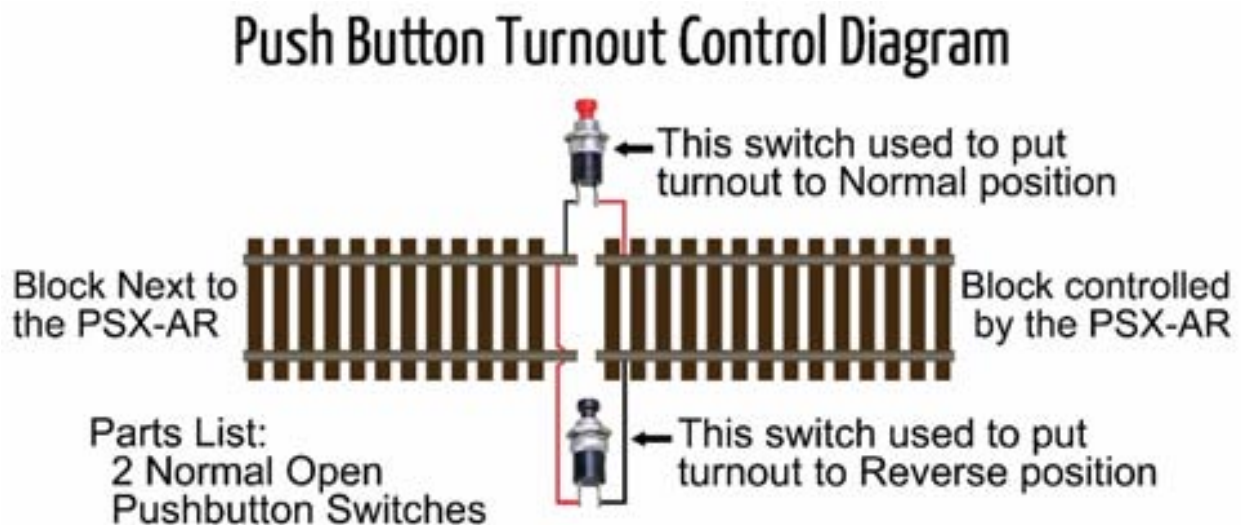

L. Add On Circuits for the PSX-AR [Continued] by Don Fiehmann

- 2) **LED Indication for Layout Map Display:** There are times when you need to know which way the PSX-AR is set (reversed or normal). Here is a simple circuit that uses an LED to indicate the polarity setting of the PSX-AR. It only uses three standard parts. If you have block occupancy detection circuits the resistor value should be high enough not to trip the detector circuit. The 1 K value is a starter and if you have problems you can go much higher and still get a good light from the LED. Circuit connects between a reversing section and the normal trackage.

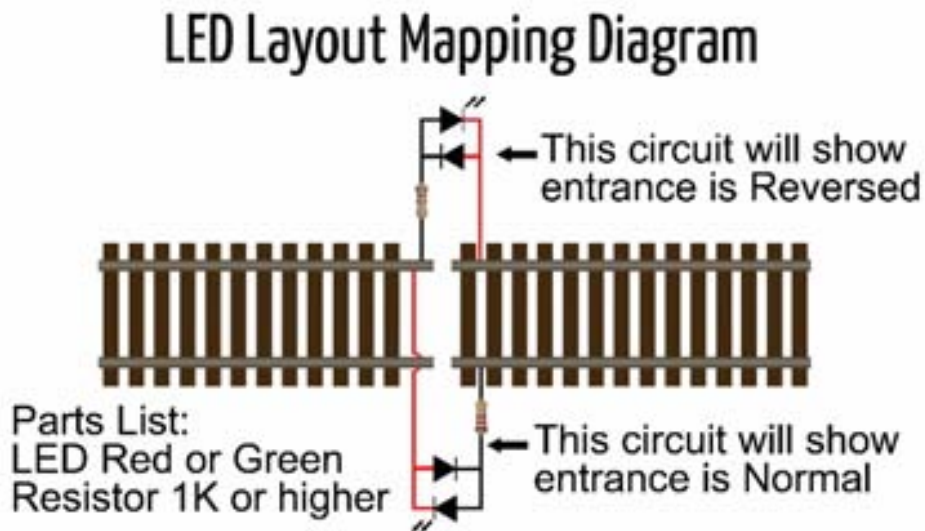

M. System Sequential Programming Instructions for Setting Address and Programming CV's

Digitrax Using the DT400/402/500 Setting PSX Addresses:

1. Disconnect PSX from DCC power
2. Move PSX Jumper to Program Position Pins 1 & 2
3. Turn DCC power on "PWR"+ " Y+"
4. After 30 seconds, reconnect DCC power
5. Press "SWCH" key to enter Switch Mode
6. Select the switch number to be set using the keypad or RH knob.
7. Press either the "OPTN" or "CLOC" key to set address.
8. Repeat steps 6 and 7 until all addresses set.
9. Press "EXIT" key to return to LOCO mode.
10. Turn DCC power off "PWR" " N –".
11. Move PSX J3 Jumper to Run Position
12. Turn track power on.
13. Test the switch address setting by using the "SWCH" key and switch addresses.

Digitrax Programming PSX CVs: Using DT400/402/500 Do Setting Addresses First

1. Disconnect PSX from DCC power.
2. Move PSX J3 Jumper to Program Position Pins 1 & 2
3. Turn DCC power on "PWR" " Y+"
4. After 30 seconds, connect DCC power to the PSX
5. Select an unused locomotive number with the keypad or RH knob.
6. Press "PROG " key until you get from Pg to Po
7. Use LH throttle dial to set the CV # and the RH throttle for the CV value.
8. Press ENTER
9. Repeat steps 7 & 8 until all the CV values are set.
10. Press EXIT
11. Turn DCC power off "PWR" " N –".
12. Move PSX J3 Jumper to Run Position
13. Turn track power on.

Lenz Setting PSX Addresses: Using the LH100

1. Turn DCC power off.
2. Move PSX J3 Jumper to Program Position Pins 1 & 2
3. Turn DCC power on
4. Press "F5" key to select "SW" mode.
5. Enter the switch number to be set using the keypad
6. Press ENTER.
7. Press either the "+" or " – " key to set the address. Let LED blink once.
8. Press the "CI" key to enter another address.
9. Repeat steps 5-7 until all addresses are set.
10. Press "ESC" key to return to normal.
11. Turn DCC power off.
12. Move PSX J3 Jumper to Run position Pins 2 & 3
13. Turn track power on.
14. Test the switch address setting using "SW" mode and the new switch address[es].

For all systems, whenever you enter an address or CV value, you should see D6 flash. This indicates the PSX-AR has received the information, stored it, and verified the stored data match the data you sent.

Lenz Programming PSX CVs: Using the LH100

1. Turn DCC power off.
2. Move PSX J3 Jumper to Program Position Pins 1 & 2
3. Turn DCC power on.
4. Select a locomotive number with the keypad that is unused on your layout.
5. Press the “F” keys and the “+” or “-” key to select “POM” mode then hit “Enter”.
6. Press “+” or “-” until “CV” is displayed then press “Enter”.
7. Press the desired CV number
8. Press “Enter”
9. Enter the CV value to change
10. Press “Enter”.
11. The display will show the CV number and value to be programmed.
12. Press "Enter" to program the CV, note the LED on the PSX flashes when the key is released
13. Press "Esc" key to return to Step 7] or press "Esc" three times to exit CV programming
14. Turn power off
15. Move PSX J3 Jumper to Run position Pins 2 & 3

NCE Setting PSX Addresses: Using Pro Cab or Power Cab

1. Turn DCC Power off.
2. Move PSX J3 Jumper to Program Position Pins 1 & 2
3. Turn DCC Power on.
4. Press SELECT ACCY.
5. Enter the new switch number using the numerical keypad.
6. Press ENTER
7. Press either 1 or 2 to set the address.
8. Repeat steps 4 thru 6 until all of the switch addresses are set.
9. Turn DCC Power off.
10. Move PSX J3 Jumper to Run position Pins 2 & 3
11. Turn DCC Power on.
12. Test the switch setting using the SELECT ACCY key.

NCE Programming PSX CV's: NCE Pro Cab or Power Cab

1. Turn DCC Power off.
2. Move PSX J3 Jumper to Program Position Pins 1 & 2
3. Turn DCC Power on.
4. Use SELECT LOCO to address an unused locomotive number.
5. Press PROG/ESC key to enter PROGRAM ON MAIN mode.
6. Press ENTER to select any unused locomotive number
7. Press ENTER again.
8. Press 2 to enter PROG CV NUM.
9. Enter CV number
10. Press ENTER.
11. Enter value to be stored
12. Press ENTER.
13. Repeat steps 8 and 9 until finished.
14. Press PROG/ESC to return to normal operation.
15. Turn power off
16. Move PSX J3 Jumper to Run position Pins 2 & 3
17. Turn power on.
18. Test the PSX using the SELECT ACCY key.

For all systems, whenever you enter an address or CV value, you should see D6 flash. This indicates the PSX-AR has received the information, stored it, and verified the stored data match the data you sent.

MRC Setting PSX Addresses: Using the Prodigy Advance Cab

1. Turn DCC Power off.
2. Move PSX J3 Jumper to Program Position Pins 1 & 2
3. Turn DCC Power on.
4. Press ACCY key.
5. Enter the new switch number using the numerical keypad.
6. Press ENTER
7. Press either 1 or 2 to set the address.
8. Repeat steps 4 thru 6 until all of the CV value are set.
9. Turn DCC Power off.
10. Move PSX J3 Jumper to Run Position Pins 2 & 3
11. Turn DCC Power on.
12. Test the switch setting using the ACCY key.

MRC Programming PSX CVs: Prodigy Advance Cab

1. Turn DCC Power off.
2. Move PSX J3 Jumper to Program Position Pins 1 & 2
3. Turn DCC Power on.
4. Press LOCO to address an unused locomotive number.
5. Press PROG key to enter PROG MAIN TRACK mode
6. Press ENTER.
7. Continue to press ENTER until CV# is in the display.
8. Enter the CV number
9. Press ENTER.
10. Enter the value to be stored in the CV
11. Press ENTER.
12. Repeat steps 8 and 9 until finished.
13. Press ENTER to return to normal operation.
14. Turn power off
15. Move PSX J3 Jumper to Run position Pins 2 & 3
16. Turn DCC power on.
17. Test the PSX using the ACCY key.

For all systems, whenever you enter an address or CV value, you should see D6 flash. This indicates the PSX-AR has received the information, stored it, and verified the stored data match the data you sent.

Audible Short Indication The two holes inside the circle [U8] on the top of the board are for use with an audible short indicating device. It is designed for use with part no. ttxsonalert. The device is installed with the [+] terminal in the square hole.

**You can obtain these components for all PSX devices from
American Hobby Distributors: 800.671.0641 info@dccspecialties.com**



Part no. ttxsonalert
Audio Alert



Part no. screwtermkitpsx1
Screw Terminal Kit for PSX



Part no. dsppsx.pb
Reset Push Button Switch