

DAJ

MODEL:06A-618BR

USERS MANUAL

3-IN-1 FLOORING NAILER

SAVE THIS MANUAL FOR FUTURE REFERENCE

WARNING:

Failure to follow warnings could result in
DEATH OR SERIOUS INJURY.

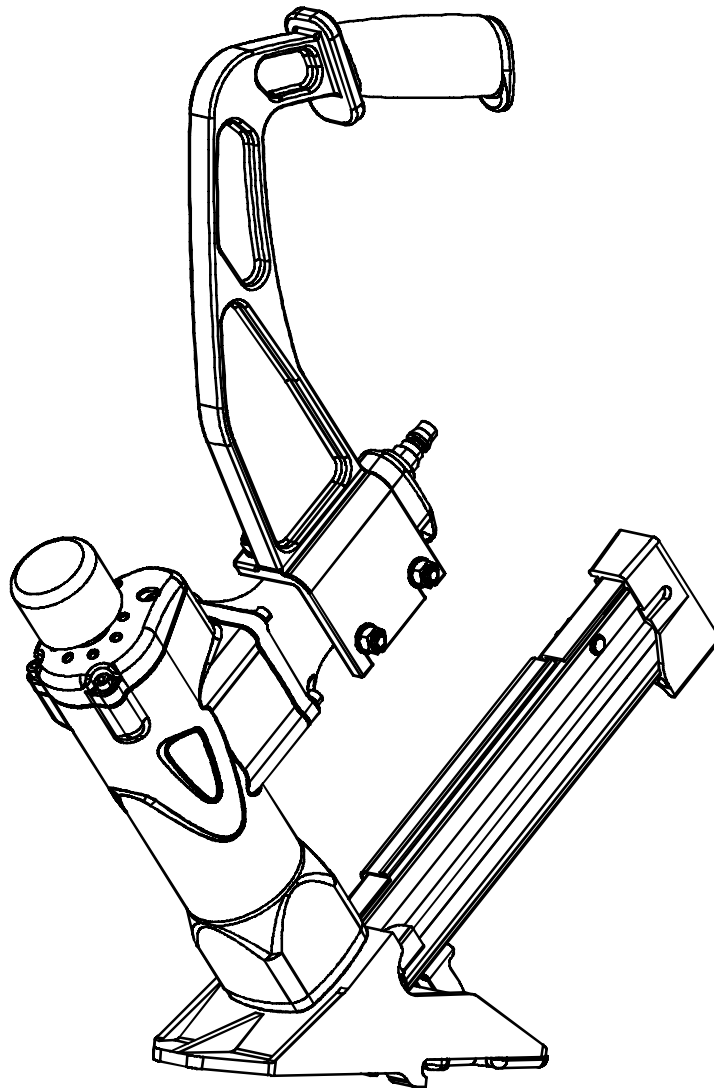

- TAIZHOU DAJIANG IND.CO.,LTD.
- Machinery & Electronics Zone of Ind.City,
Wenling, Zhejiang Prov.,317500,P.R.China
- www.chinaairtool.com

DAJ M0502 V2

CONTENTS:

IMPORTANT INFORMATION	P1
EXPLANATION OF THE NAILING ACTION	P1
GENERAL SAFETY RULES	P1
WORK AREA	P1
PERSONAL SAFETY	P1
TOOL USE AND CARE	P1
SERVICE	P2
AIR SOURCE	P2
DESCRIPTION AND SPECIFICATION	P3
SPECIFICATION	P3
FEATURES	P4
ASSEMBLY/INSTALLATION	P4
OPERATION	P4
LUBRICATION	P4
ADJUSTING AIR PRESSURE	P4
CONNECTING AIR SUPPLY	P5
NAIL LOADING	P5
CHANGING THE FOOT PLATE	P6
OPERATING THE TOOL	P6
COLD WEATHER OPERATION	P6
MAINTENANCE	P6
JAM CLEARING	P6
CLEANING	P7
STORAGE	P7
HOOKUP INSTRUCTIONS FOR TOOL TO AIR SUPPLY	P7
RECOMMENDED HOOKUP	P7
TROUBLE SOLVING	P8

IMPORTANT INFORMATION

WARNING

TO AVOID SERIOUS PERSONAL INJURY, ALL USERS AND EMPLOYERS/OWNERS MUST READ AND UNDERSTAND ALL INSTRUCTIONS IN THIS MANUAL BEFORE OPERATING OR MAINTAINING THIS TOOL.

Keep this manual for the safety warnings and precautions, operating, inspection, maintenance. Keep this manual and the receipt in a safe and dry place for future reference.

GENERAL SAFETY RULES

WORK AREA

- ◆ **KEEP THE WORK AREA CLEAN AND WELL LIGHTED.**
Cluttered benches and dark areas increase the risks of accidents.
- ◆ **DO NOT OPERATE THE TOOL IN EXPLOSIVE ATMOSPHERES,** such as in the presence of flammable liquids, gases, or dust. The tool creates a spark which may ignite flammable liquids, gases or dust.
- ◆ **KEEP VISITORS AWAY.** Do not let visitors handle the tool. All visitors should be kept safety away from work area.
- ◆ **NEVER ENGAGE IN HORSEPLAY WITH THE TOOL.**
Respect the tool as a working implement.

PERSONAL SAFETY

- ◆ **OPERATORS AND OTHERS IN WORK AREA MUST WEAR SAFETY GLASSES WITH SIDE SHIELDS.** When operating the tool, always wear safety glasses with side shields, and make sure others in work area wear safety glasses. Safety glasses must conform to the requirements of American National Standards Institute, ANSI Z87.1 and provide protection against flying particles both from the front and side. The employer must enforce the use of safety glasses by the tool operator and others in work area.
- ◆ **ALWAYS WEAR EAR AND HEAD PROTECTION.** Always wear ear protection to protect your ears from loud noise, Always wear head protection to protect your head from flying objects.
- ◆ **USE SAFETY EQUIPMENT.** A dust mask, non-skid safety shoes and a hard hat must be used for the applicable conditions. Wear a full face shield if you are producing metal filings or wood chips.
- ◆ **DRESS PROPERLY.** Do not wear loose clothing or jewelry. Contain long hair. Keep your hair, clothing, and gloves away from moving parts. Loose clothes, jewelry, or long hair can be caught in moving parts and increases the risk of injury.

- ◆ **STAY ALERT, WATCH WHAT YOU ARE DOING AND USE COMMON SENSE WHEN OPERATING A POWER TOOL.** Do not use tool while tired or under the influence of drugs, alcohol, or medication. A moment of inattention while operating the tool may cause serious injury.
- ◆ **AVOID UNINTENTIONAL FIRING.** Keep fingers away from trigger when not driving fasteners, especially when connecting the tool to the air supply.
- ◆ **DO NOT OVERREACH.** keep proper footing and balance at all times. Proper footing and balance enable better control of the tool in unexpected situations.
- ◆ **MAKE SURE AIR HOSE IS FREE OF SNAGS AND OBSTRUCTIONS. DO NOT ATTACH AN AIR HOSE OR TOOL TO YOUR BODY.** Entangled or snarled hoses can cause a loss of balance or footing in addition to unintentional tool operation. Attach the hose to the structure to reduce the risk of loss of balance of the hose shifts.

TOOL USE AND CARE

- ◆ **NEVER POINT TOOL AT YOURSELF OR OTHERS IN WORK AREA.** Always assume the tool contains fasteners. Never point the tool at yourself or others, whether it contains fasteners or not. If fasteners are mistakenly driven, it can lead to severe injuries. Never engage in horseplay with the tool. Respect the tool as a working implement.
- ◆ **NEVER MODIFY OR ALTER A TOOL.** Doing so may cause malfunction and personal injuries.
- ◆ **KNOW THIS TOOL.** Read manual carefully, learn its applications and limitations, as well as the specific potential hazards related to this tool.
- ◆ **USE ONLY FASTENERS THAT ARE RECOMMENDED FOR YOUR MODELS.** Do not use the wrong fasteners or load the fasteners incorrectly.
- ◆ **CHECK FOR MISALIGNMENT OR BINDING OF MOVING PARTS, BREAKAGE OF PARTS, AND ANY OTHERS CONDITION THAT MAY AFFECT THE TOOL'S OPERATION.** If damaged, have the tool serviced before using. Many accidents are caused by poorly maintained tools.
- ◆ **NEVER USE TOOL WHICH IS DEFECTIVE OR OPERATING ABNORMALLY.** If the tool appears to be operating unusually, making strange noises, or otherwise appears defective, stop using it immediately and arrange for repairs by an authorized service center.
- ◆ **MAINTAIN TOOLS WITH CARE.** Keep the tool clean and lubricated for better and safer performance.
- ◆ **NEVER CARRY THE TOOL BY AIR HOSE.**
- ◆ **STORE TOOLS OUT OF THE REACH OF CHILDREN AND OTHER UNTRAINED PEOPLE.** Tools are dangerous in the hands of untrained users.

- ◆ PLACE TOOL PROPERLY ON WORKPIECE. Do not drive fasteners on top of other fasteners or with the tool at too steep of an angle; the fasteners can ricochet and hurt someone.
- ◆ DO NOT USE THE TOOL AS A HAMMER.
- ◆ KEEP ALL SCREWS AND COVERS TIGHT IN PLACE.
- ◆ KEEP FACE, HANDS AND FEET AWAY FROM FIRING HEAD AT ALL TIMES. Never place your face, hands or feet near the firing head.
- ◆ NEVER PLACE A HAND OR ANY PART OF BODY IN FASTENER DISCHARGE AREA OF TOOL.
- ◆ DISCONNECT AIR HOSE FROM TOOL WHEN:
 - 1) Doing maintenance and inspection;
 - 2) Clearing a jam;
 - 3) It is not in use;
 - 4) Leaving work area;
 - 5) Moving it to another location;
 - 6) Handing it to another person.Never attempt to clear a jam or repair the tool unless you have disconnected air hose from the tool and removed all remaining fasteners from the tool. The tool should never be left unattended since people who are not familiar with the tool might handle it and injure themselves.

TOOL SERVICE

- ◆ USE ONLY ACCESSORIES THAT ARE IDENTIFIED BY THE MANUFACTURER FOR THE SPECIFIC TOOL MODEL
- ◆ USE OF UNAUTHORIZED PARTS OR FAILURE TO FOLLOW MAINTENANCE INSTRUCTIONS MAY CREATE A RISK OF INJURY
- ◆ USE ONLY THE LUBRICANTS SUPPLIED WITH THE TOOL OR SPECIFIED BY THE MANUFACTURER.
- ◆ TOOL SERVICE MUST BE PERFORMED ONLY BY QUALIFIED REPAIR PERSONNEL

AIR SOURCE

- ◆ NEVER USE OXYGEN OR OTHER BOTTLED GASES AS A POWER SOURCE. Explosion may occur. Combustible gases and other bottled gases are dangerous and may cause the tool to explode.
- ◆ DO NOT EXCEED MAXIMUM RECOMMENDED AIR PRESSURE MARKED ON THE TOOL. Use only clean, dry, regulated, compressed air within the rated pressure range marked on the tool. Never connect the tool to pressure as which potentially exceeds 200PSI the tool can burst.
- ◆ DO NOT ABUSE THE AIR HOSE. Protect all hoses from kinks, restrictions, solvents or sharp objects. Keep air hose away from heat, oil, sharp edges or moving parts. Replace damaged hoses immediately. Damaged hoses can burst or whip around.
- ◆ CHECK ALL FITTINGS, HOSES, PIPES, CONNECTIONS AND COMPRESSOR BEFORE EACH USE OF THIS TOOL. Repair or replace damaged or leaking hoses and connections immediately. Damage to a hose or connection can cause a pressure hose to break and whip around the work area, and can lead to injury.

FUNCTIONAL DESCRIPTION AND SPECIFICATIONS

⚠ WARNING

Disconnect the tool from the air source before making any adjustments, changing accessories or storing the tool. Such precautionary safety measures reduce the risk of unintentional tool operation.

FIG. 1

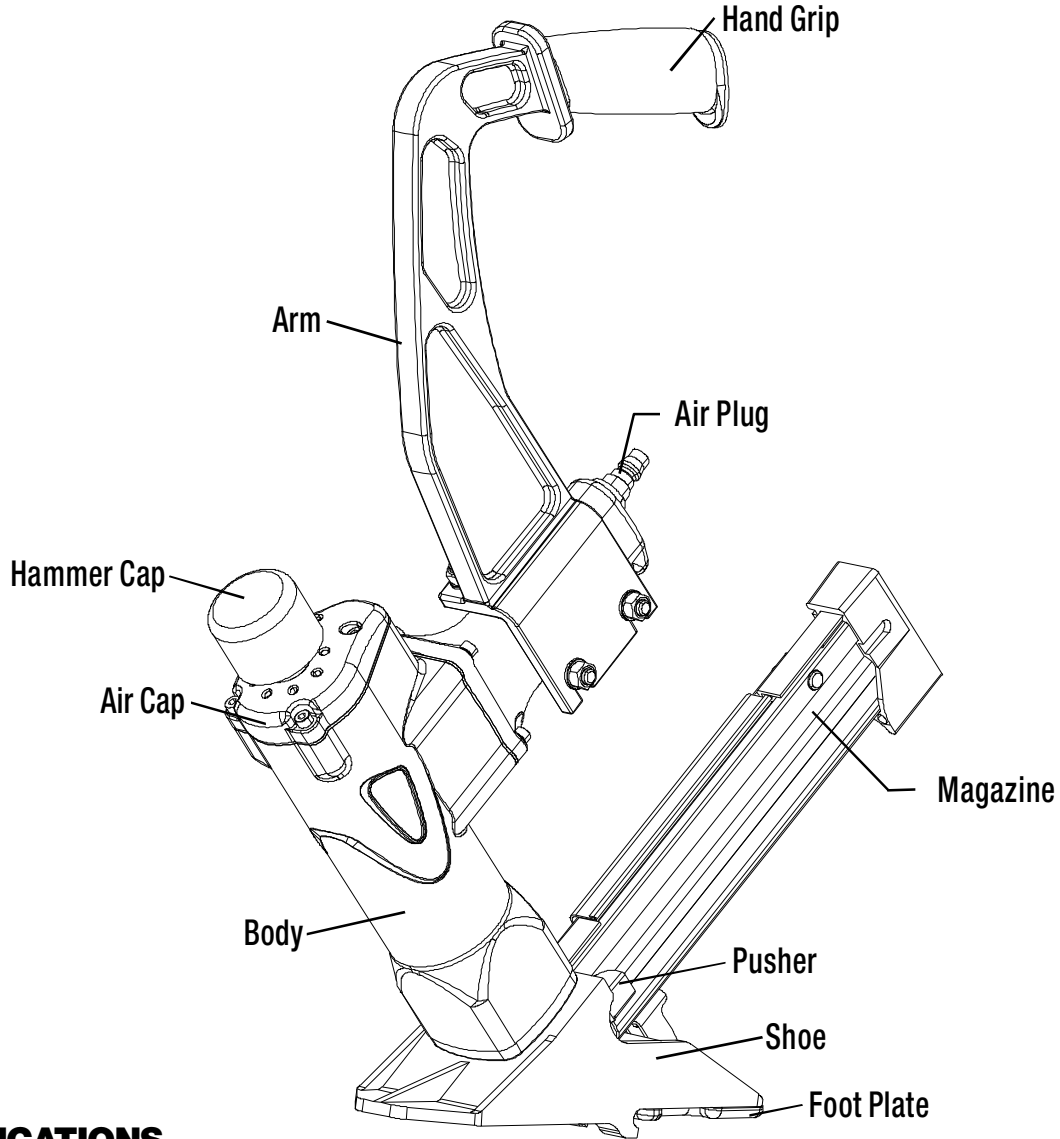

SPECIFICATIONS

Product Size:

Length – 20.1"(510mm)

Height – 22.8"(580mm)

Width – 3.54"(90mm)

Weight: 11.2lbs(5.1kg)

Normal Operating Pressure: 70–115psi(5–8bar)

Magazine Capacity:

T cleat: 100 pcs

L cleat: 100pcs

Staple: 120pcs

Fastener Size Range:

T cleat: 1–1/2" – 2"(38–50mm)

L cleat: 1–1/2" – 2"(38–50mm)

Staple: 1–1/2" – 2"(38–50mm)

Fastener Type

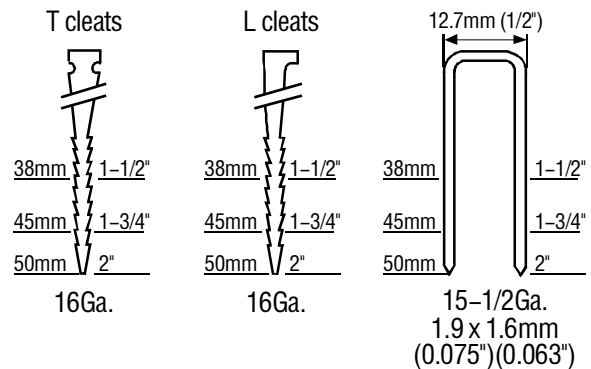

FEATURES

- ◆ Well balanced hardened driver blade for a longer life.
- ◆ Ergonomic design for less fatigue.
- ◆ Composite base to eliminate scratch and damage to the surface of the wood.
- ◆ Mallet included.

ASSEMBLY/INSTALLATION

Follow the instructions below to prepare your tool for operation.

1. All tool operators and their immediate supervisors must become familiar with the operator safety instructions before operating the tool.
2. Included with each tool are one copy of these Operating/Safety Instructions. Keep this publications for future reference.
3. Install a filter, regulator, lubricator unit and moisture trap on your air delivery system per the manufacturer's instructions for these devices. Additionally, install a pressure gauge as close as practical to the tool, preferably within 10 feet.
4. Select hoses with a minimum inner diameter of 1/4 inches and a maximum length of 100 feet.

⚠ WARNING

To reduce the risk of injury from a hose bursting, select hoses that are rated at least 200PSI.

5. Select fittings that are appropriately sized for the selected hoses. The tool and air hose must have a hose coupling such that all pressure is removed from the tool when the coupling joint is disconnected.

⚠ WARNING

Never use non relieving couplers and/or female quick disconnect couplings on the tool. Non relieving couplings and female couplings will trap high pressure air in the tool when the air line is disconnected. This will leave the tool charged with enough air after it has been disconnected to drive a nail. Only MALE pneumatic type air connectors should be fitted to the tool, so that high pressure air in the tool is vented to atmosphere as soon as the air line is disconnected.

6. Set the regulator at the air delivery system to a PSI that falls within the tool's operating range of 70–115PSI. The correct pressure is the lowest pressure that will do the job.

OPERATION

LUBRICATION

⚠ WARNING

USE ONLY THE AIR TOOL LUBRICANTS SUPPLIED WITH THE TOOL. Do not use other lubricants as they may damage the tool.

If the tool is not used with an in-line lubrication system on the air supply it is necessary to periodically lubricate the tool with air tool lubrication.

Under low use, lubricate once a day. Under heavy use, lubricate twice a day. To lubricate, insert 2–3 drops of lubricant into the air supply fitting attached to the tool handle (FIG 2). Using too much oil will cause it to collect in the tool and be noticeable in the exhaust.

FIG. 2

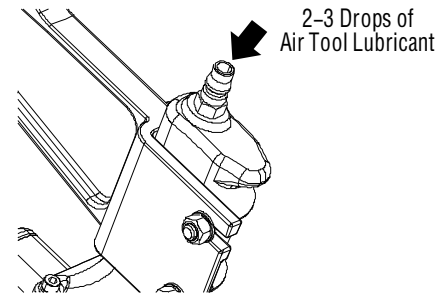

Do not use detergent oil, WD-40, transmission fluid, motor oil, or other lubricants not specifically designated as air tool lubricants. These lubricants will cause accelerated wear to the seals, o-rings, and bumpers in the tool, resulting in poor tool performance and frequent maintenance.

ADJUSTING AIR PRESSURE

Adjust the air pressure at recommended operating pressure 70–115PSI according to the length of nails and the hardness of workpiece.

The correct air pressure is the lowest pressure which will do the job. Using the tool at a higher than required air pressure unnecessarily over stresses the tool. Don't exceed 115PSI.

FIG. 3

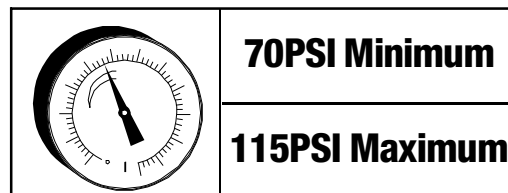

CONNECTING AIR SUPPLY

⚠ WARNING

Never use oxygen or other bottled gases as a power source. Explosion may occur. Combustible gases and other bottled gases are dangerous and may cause the tool to explode.

⚠ WARNING

Never connect the tool to an air source that is capable of producing air pressure exceeding 200PSI. Excessive pressure can cause abnormal operation or cause the tool to burst, resulting in personal injury.

⚠ WARNING

Do not exceed maximum recommended air pressure marked on the tool. Verify prior to using the tool that the air source has been adjusted within the rated air-pressure range. Be sure the air pressure gauge is operating properly and check it at least twice a day. Tools operated in excess of their maximum pressure rating may operate abnormally or burst resulting in personal injury.

To connect the tool to the compressor only use pneumatic air hoses that meet the following criteria:

1. Minimum hose pressure rating, 200PSI.
2. Minimum hose inner diameter, 1/4 in.
3. Maximum hose length, 100 ft.

FIG. 4

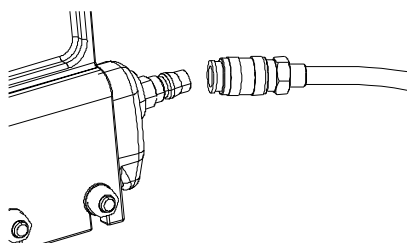

CONNECT THE AIR SUPPLY:

- Snap the air hose onto the quick connector.
- Check for air leakage. If leakage is noted, stop using the tool and perform repair by qualified personnel immediately .
- Be sure the air pressure gauge is operating properly and check it at least twice a day.

NAIL LOADING

⚠ WARNING

Connecting the air supply after loading nails reduces the risk of unintentionally driving a nail and injuring yourself or someone else.

LOADING CLEAT NAILS

1. Connect air supply.
2. Pull the pusher back to the end of magazine. Lock pusher in the place by lock button. Then pull the magazine side shelter back.
3. Place full clip of desired fasteners into magazine from the side. Up to 100 cleat nails can be loaded into magazine. Be noted that, when holding the L cleat nails, the side with the L head should be in the left of the magazine side shelter. Press the lock button, then the pusher set back to make the magazine side shelter down back.

FIG. 5

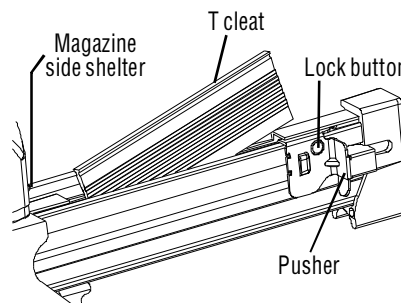
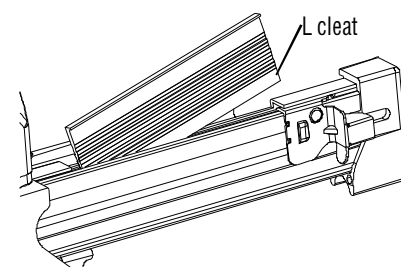

FIG. 6



LOADING STAPLES

1. Connect air supply.
2. Pull the pusher back to the end of magazine. Lock pusher in the place by lock button. Then pull the magazine side shelter back.
3. Place a full clip of 1/2" Crown Staples in the magazine from the top. Up to 2 x 45pcs to 2 x 60pcs can be loaded into the tool.
4. Press the lock button, then the pusher sets back to make the magazine side shelter down back.

FIG. 7

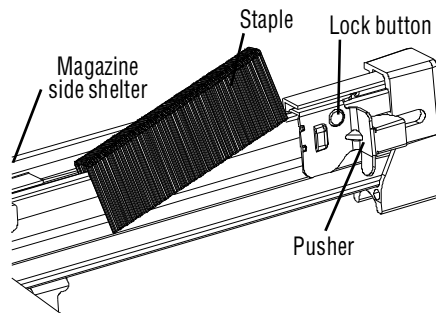

CHANGING THE FOOT PLATE

⚠ WARNING

Disconnect the tool from the air source whenever changing the foot plate. Make sure there is no fastener in magazine before changing the foot plate.

1. Disconnect tool from air supply.
2. Empty the magazine completely.
3. Fire the tool into a piece of scrap wood to ensure there is no compressed air fasteners left in the tool.
4. Set the tool on its side to expose the three screws.
5. Remove the three screws, then, remove the foot plate.
6. Align the three screw holes in the replacement foot plate with the three threaded mounting holes.
7. Using the three screws you removed just now, secure the replacement foot plate to the tool.
8. Ensure the correct foot plate is installed by firing into a scrap piece of flooring and checking for proper fastener placement.

FIG. 8

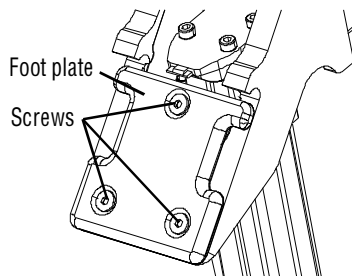

OPERATING THE TOOL

⚠ WARNING

Extreme caution whenever this tool is connected to an air resource. If the tool is dropped, or if the hammer cap is accidentally struck, then the tool will fire a fastener, potentially causing **SERIOUS PERSONAL INJURY**.

⚠ WARNING

Keep your feet off the tool.

⚠ WARNING

Before using the tool on a floor, test the tool on a scrap piece of wood. Adjust the driving depth by providing more or less air pressure.

1. Attach the tool to the air resource. Start your compressor and check the pressure, making sure it is set between 70–110psi.
2. Hold the arm securely and press foot plate to the work surface. Make sure the plate is over the fastener target position.
3. Press down hard so that the foot plate is firmly

contacting the work surface. Then, using the mallet packet with the tool, strike the hammer cap firmly to drive the fastener into work surface. Lift the tool off the work surface. Repeat this process until the job is completed.

4. When finished, make sure to store the tool in a clean, dry, safe location out of reach of children and other unauthorized people.

FIG. 9

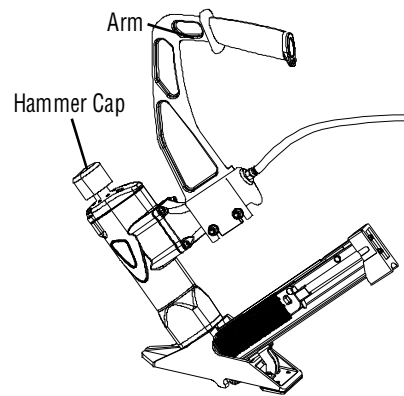

COLD WEATHER OPERATION

⚠ WARNING

DO NOT USE A FROZEN TOOL. Allow tool to thaw before using. Moisture frozen in the tool may impede internal components resulting in the risk of injury and/or tool damage.

When using the tool in cold conditions the tool will cycle slower than usual while driving the first nails. The cycle rate will increase as the tool warms up. Keep tool warm to avoid reduced cycle rate.

MAINTENANCE

JAM CLEARING

Remove a jammed nail as the following order:

1. Disconnect air hose.
2. Remove all nails.
3. Try to fire the tool into a piece of scrap wood or flooring to make sure that it's incapable of firing any fasteners.
4. Lean the tool back. With the Driver guide facing away from you, remove the three Hex. Bolts. Then remove the Driver guide to expose the jammed fastener.
5. Removed jammed fastener, using pliers or Screwdriver if required.
6. Replace the Driver guide and Hex. Bolts.

7. Press the Driver guide against a piece of wood, and test fire the fasteners several times to check for proper operation. If the tool is properly firing, you may continue using the tool. If the tool fails to perform properly, immediately discontinue use and have the tool repaired by a qualified service technician. When finished working, disconnect the air resource.
8. Remove fasteners. Discharge any trapped air. Then store the tool in a clean, dry, safe location out of reach of children.

FIG. 10

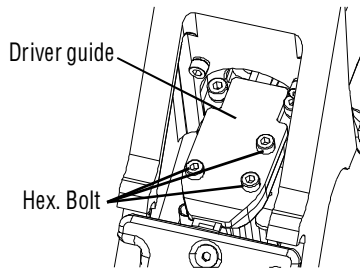

⚠ WARNING

Make sure there is no fastener in magazine before clearing a jam.

⚠ WARNING

Disconnect the tool from the air source whenever clearing a jam. After disconnecting the tool from the air compressor, there should still be enough air pressure to fire the tool. After the air hose is disconnected, always fire the tool into scrap wood repeatedly to make sure all of the compressed air is expended.

CLEANING

⚠ WARNING

When cleaning a tool be careful not to disassembly any portion of the tool since internal components may be misplaced or safety components may be improperly mounted. Certain cleaning agents such as gasoline, carbon tetrachloride, ammonia, etc. may damage plastic parts and o-rings.

⚠ WARNING

Do not attempt to clean by inserting pointed objects through openings. Sharp edges may damage internal components causing a serious hazard.

Ventilation openings, the work contact element, and the trigger must be kept clean and free of foreign matter. Periodically clean the tool with compressed air.

Clean the magazine. Remove metal or wooden chips which may have accumulated in the magazine. Periodically clean magazine with compressed air.

STORAGE

⚠ WARNING

Keep out of reach of children and personnel unfamiliar with tool operation. Lock the storage area. Tools are dangerous in the hands of personnel unfamiliar with the tool.

When not in use, the tool should be disconnected and stored in the storage case in a warm and dry place. When tool will not be in use for an extended period, apply a thin coat of the lubricant to the steel parts to avoid rust.

Do not store the tool in a cold weather environment.

HOOKUP INSTRUCTIONS FOR TOOL TO AIR SUPPLY

NOTE:

For better performance, install a 3/8 inch quick plug(1/4 inch NPT threads) with an inside diameter of 0.315 inch (8mm) on the nailer and a 3/8 inch quick coupler on the air hose.

1. With ON/OFF switch in OFF position, plug compressor into electrical outlet.
2. Close pressure regulator by turning all the way to the left. Turn compressor ON and let it pump all the way up to automatic shut-off pressure.
3. Attach air hose to regulator outlet. Adjust pressure regulator by turning to the right so that outlet pressure is between 70PSI to 110PSI.
4. Load fasteners into nailer.
5. Point the nailer in a safe direction while attaching to air hose.
6. Nailer is ready for use. You may need to adjust outlet pressure to achieve proper fastener depth.

RECOMMENDED **HOOKUP**

MINIMUM COMPONENTS REQUIRED FOR HOOKUP

Air compressor: The air compressor must be able to maintain a minimum of 70PSI when the nailer is being used. An inadequate air supply can cause a loss of power and inconsistent driving.

Pressure regulator: A pressure regulator is required to control the operating pressure of the nailer between 70PSI and 110PSI.

Air supply hose: Always use air supply hoses with a minimum working pressure rating equal to or greater than the pressure from the power source, or 150PSI, whichever is greater. Use 1/4 inch air hose for runs up to 50 feet. Use 3/8 inch air hose for 50 feet, run or longer.

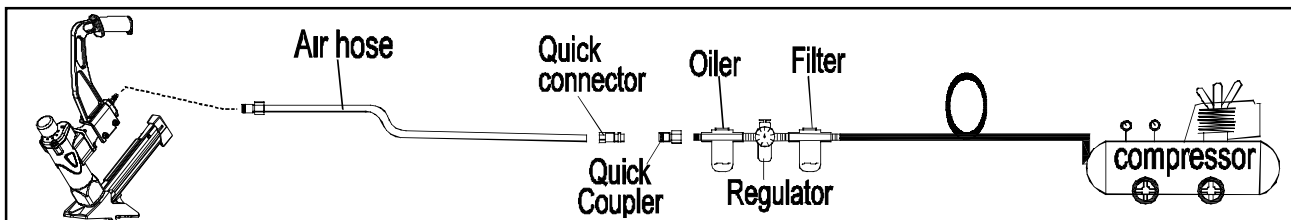

TROUBLE SOLVING

PROBLEMS	POSSIBLE CAUSES	CORRECTION ACTIONS
Air leaking in head cap.	<ol style="list-style-type: none"> 1. Loose screws. 2. Worn or damaged O-rings or seals. 	<ol style="list-style-type: none"> 1. Tighten screws. 2. Install overhaul kit.
Lack of power. Slow to cycle.	<ol style="list-style-type: none"> 1. Tool is too dry. 2. Air pressure too low. 3. Exhaust blocked. 	<ol style="list-style-type: none"> 1. Add about 2–3 drops of lubrication into the air connector. 2. Make sure the air compressor is set between 70psi and 115psi. 3. Clean exhaust channel.
Not shooting fasteners .	<ol style="list-style-type: none"> 1. Damaged pusher spring. 2. Wrong size of fasteners. 	<ol style="list-style-type: none"> 1. Replace spring. 2. Use 1/2" crown staples.
Fasteners are jammed in the tool frequently.	<ol style="list-style-type: none"> 1. Drive channel is worn. 2. Piston is broken or worn. 3. Bent fasteners. 4. Dirty magazine. 5. Loose magazine. 6. Wrong fasteners. 	<ol style="list-style-type: none"> 1. Fix the drive channel. 2. Replace the piston. 3. Remove the bent fasteners, replace with the 1/2" crown staples. 4. Clean magazine. 5. Tighten screws. 6. Verify that fasteners are the correct size.

