



## Product Data

# 38TG (60 Hz) Air Conditioner

Sizes 014 thru 060

**FILE  
COPY**

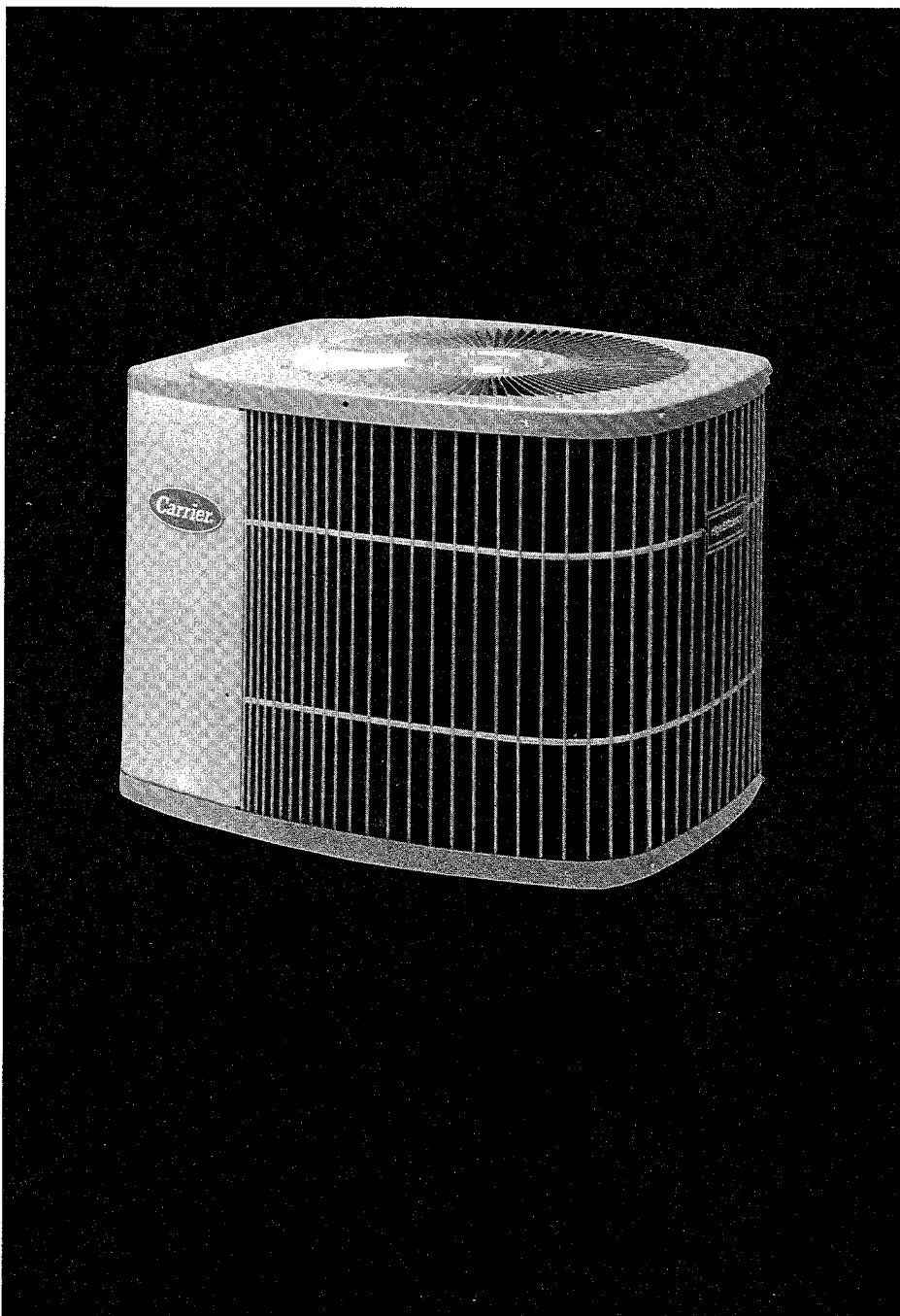

Model 38TG Energy-Efficient Air Conditioner incorporates innovative technology to provide quiet, reliable summer cooling performance. Built into these units are the features most desired by homeowners today, including SEER ratings of at least 8.0 when used with components as designated by manufacturer. All models are listed with U.L., CSA, ARI and CEC.

### FEATURES/BENEFITS

**Electrical Range**—Units are offered in 208/230-volts single phase, 208/230-volts three phase and 460-volts three phase.

**Wide Range of Sizes**—Available in eight nominal sizes from 014 thru 060 to meet the needs for residential and light commercial applications.

**Weather Armor II Cabinet**—Steel is protected with a heavy coating commonly called “galvanizing,” then coated with a layer of zinc phosphate to which a coat of modified polyester powder coating is applied and baked-on. This provides each unit with a hard, smooth finish that will last for many years.

All screws on cabinet exterior are coated for a long-lasting, rust-resistant, quality appearance.

**Totally Enclosed Fan Motor**—Means greater reliability under rain conditions and dependable performance for many years. Permanent-split-capacitor-type motors provide more economical operation. (Ball bearing fan motors standard on three phase units.)

**Unit Design**—Copper tube, enhanced sine wave aluminum fin coil is designed for optimum heat transfer. Vertical air discharge carries

sound and hot condenser air up and away from adjacent patio areas and foliage. New heat pump style drain pan for easy removal of water, dirt and leaves.

**Application Versatility**—The 38TG can be combined with a wide variety of evaporator coils and blower packages to provide quiet, dependable comfort. Unit can be installed on a roof or at ground level.

**External Service Valves**—Both service valves are brass, back seating type with sweat connections. Valves are externally located so refrigerant

tube connections can be made quickly and easily. Each valve has a service port for ease of checking operating refrigerant pressures.

**Easy Serviceability**—One access panel provides access to electrical control box and compressor. Removal of top gives access to fan motor and coil.

**Compressor Protection**—Each compressor is protected with internal temperature- and current-sensitive overloads. An internal pressure relief valve provides high-pressure protection to the refrigerant system.

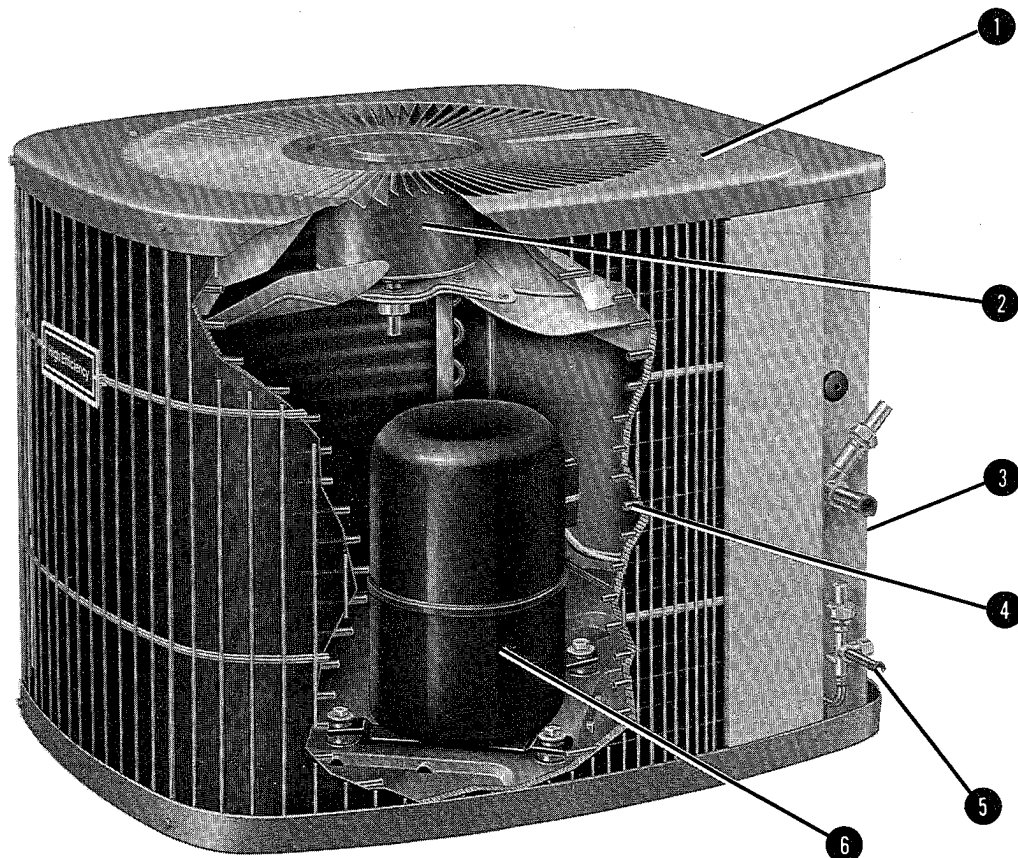

A88425

- |                             |                                 |
|-----------------------------|---------------------------------|
| 1 Weather Armor™ II Cabinet | 4 Copper Tube/Aluminum Fin Coil |
| 2 High-Efficiency Fan Motor | 5 Solid Brass Service Valves    |
| 3 Total Service Access      | 6 High-Efficiency Compressor    |

# Model number nomenclature

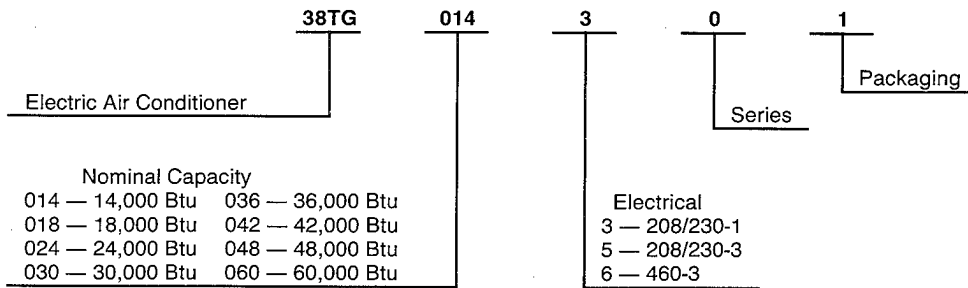

The data in this publication is displayed for all series, however every series may not be available from manufacturer.

## Physical data

MODEL 38TG	01430	01830	02430	03030 50	03631 51 61	04232 52 62	04831 51 61	06030,31 50,51 60,61
REFRIGERANT	22							
Control Charge (lbs)	2.87	2.94	3.12	AccuRater™ (Bypass Type) 3.62    4.25		5.25	5.50	8.75
COND FAN	Propeller Type, Direct Drive							
Air Discharge	Vertical							
Air Qty (Cfm)	1600			1900		3000		
COND COIL	Copper Tube, Aluminum Plate Fin							
Face Area (sq ft)	7.2		8.7	10.8		12.0	18.0	
VALVE CONNECT. (in. ID)	Sweat							
Vapor	5/8		3/4		7/8			
Liquid	3/8							
REFRIG TUBES* (in. OD)								
Vapor	5/8		3/4		1-1/8			
Liquid	1/4†				3/8			

**NOTE:** See unit Installation Instructions for proper installation.

\*Tube sizes are for runs up to 50 ft.

For tube set over 50 ft consult Long-Line Application Guideline.

†3/8 in. liquid tube must be used on capillary type coils.

### AccuRater™ Chart

Unit Size	Piston Identification No.
014-30	46
018-30	49
024-30	63
030-30	67
030-50	70
036-31	76
036-51	76
036-61	76
042-32	80
042-52	80
042-62	80
048-31	84
048-51	84
048-61	84
060-30	90
060-31	88
060-50	90
060-51	88
060-60	90
060-61	88

\*Piston listed is for any approved non-capillary tube coil combination. Piston is shipped with outdoor unit and must be installed in an approved indoor coil.

# Accessories

ORDERING NUMBER	DESCRIPTION	ORDERING NUMBER	DESCRIPTION
38TH900001	Indoor Time Delay Relay-All sizes	38TG900221	Sound Shield-Sizes 036-31
38TG900521	Motormaster Controller-Sizes 014-060 208/230V†*‡	38TG900231	Sound Shield-Sizes 048-31 and 060-31
38TG900531	Motormaster Controller-Sizes 036-060 460V†*	38TG900001	TXV (RPB)-Size 014
38TG900481	Low Ambient Motor-Sizes 014-030*‡	38TG900011	TXV (RPB)-Size 018
38TG900511	Low Ambient Motor-Sizes 036-060*	38TG900021	TXV (RPB)-Size 024
38TG900561	Low Ambient Winter Start Control†	38TG900031	TXV (RPB)-Size 030
38TG900551	Low Ambient Evaporator Freeze Thermostat†	38TG900041	TXV (RPB)-Sizes 036-042
38TG900141	Time Guard II-All Sizes	38TG900051	TXV (RPB)-Size 048
38TG900261	PTC Start Assist-Sizes 014-030 1Ø	38TG900061	TXV (RPB)-Size 060
38TG900271	PTC Start Assist-Size 036 1Ø	38TG900071	TXV (Hard Shutoff)-Size 014
<b>Standard</b>	PTC Start Assist-Sizes 036-30, 060-30 1Ø	38TG900081	TXV (Hard Shutoff)-Size 018
38TG900281	Cap-Relay Start Assist-Size 014-30	38TG900091	TXV (Hard Shutoff)-Size 024
38TG900291	Cap-Relay Start Assist-Sizes 018-30 & 024-30	38TG900101	TXV (Hard Shutoff)-Size 030
38TG900351	Cap-Relay Start Assist-Size 030-30	38TG900111	TXV (Hard Shutoff)-Sizes 036-042
38TG900311	Cap-Relay Start Assist-Sizes 036-31 & 048-31	38TG900121	TXV (Hard Shutoff)-Size 048
38TG900361	Cap-Relay Start Assist-Size 060-31	38TG900131	TXV (Hard Shutoff)-Size 060
38TG900461	Cap-Relay Start Assist-Size 042-32	38TG900151	Low Pressure Switch
38TG900401	Crankcase Heater-Sizes 036-048 208/230V 1Ø	38TG900171	High Pressure Switch
38TG900411	Crankcase Heater-Sizes 036-048 208/230V 3Ø	P502-8083S	Filter Drier-Sizes 014-024
38TG900421	Crankcase Heater-Sizes 036-048 460V 3Ø	P502-8163S	Filter Drier-Sizes 030-036
38TG900431	Crankcase Heater-Sizes 014-030 1Ø	P502-8303S	Filter Drier-Sizes 042-048
38TG900441	Crankcase Heater-Size 030 3Ø	P502-8304S	Filter Drier-Size 060
<b>Standard</b>	Crankcase Heater-Size 060-30	38TG900541	Liquid Line Solenoid Valve-All Sizes
38TG900181	Sound Shield-Sizes 014-030 1Ø	38TH900011	(4) Support Feet-4 inch-All sizes
38TG900191	Sound Shield-Size 030 3Ø	N/A	Outdoor Thermostat
38TG900471	Sound Shield-Sizes 042-32		

\*Low Ambient Motor also required for 1Ø units. Low Ambient Motor is standard on all three phase units.

†Consult Low Ambient installation instruction for application

‡014 and 018 require fan blade change to LA01RA015 (3 bladed).

N/A — Not applicable in this application.

THERMOSTAT/SUBBASE PKG.	DESCRIPTION
HH07AT174	Honeywell—Automatic changeover; One-stage heat/One-stage cool—°F
HH07AT184	Honeywell—Manual changeover; One-stage heat/One-stage cool—°F
HH07AT164	Honeywell—Automatic changeover; One-stage heat/One-stage cool—°C
HH07AT191	Honeywell—Manual changeover; One-stage heat/One-stage cool—°C
HH93AZ176	Subbase for Auto Thermostat

## Accessory Description and Usage

- 1. Indoor Time Delay Relay**

A SPST delay relay which briefly continues operation of the indoor blower motor to provide additional cooling after the compressor cycles off.

SUGGESTED USE: For improved efficiency ratings for certain combinations of indoor and outdoor units. (Refer to ARI Unitary Directory)
- 2. Motormaster—Low Ambient Operation Kit**

This solid state head pressure controller is a fan speed control device activated by a temperature sensor. It is specifically designed to control outdoor fan motor speed in response to saturated condensing temperature. For outdoor air temperatures between 55 and 0 F (12.8 and -17.8 C), it maintains condensing temperature at 100 F +/- 10 F (37.8 +/- 5 C). For single phase units a ball bearing fan motor is also required.

SUGGESTED USE: Cooling operation at outdoor temperatures below 55 F (12.8 C).  
All commercial installations. (Note: 3 phase units have ball bearing fan motors as standard)
- 3. Ball Bearing Fan Motor**

A fan motor with ball bearings which permits speed reduction while maintaining bearing lubrication.

SUGGESTED USE: Required on all single phase units where LOW AMBIENT OPERATION KIT (Item 2) has been added.
- 4. Winter Start Control**

A SPST delay relay which bypasses the low pressure switch for approximately 3 minutes to permit start up for cooling operation under low load conditions.

SUGGESTED USE: All air conditioners which have low pressure switch and where LOW AMBIENT OPERATION KIT (Item 2) has been added.
- 5. Evaporator Freeze Thermostat**

A SPST temperature actuated switch which stops unit operation when evaporator reaches freeze-up conditions.

SUGGESTED USE: All units where WINTER START CONTROL (Item 4) has been added.
- 6. Time Guard II—Compressor Short Cycle Protector**

Solid state timing device which prevents compressor rapid recycling. Control provides an approximate 5-minute delay after power to the compressor has been interrupted for any reason, including normal room thermostat cycling.

SUGGESTED USE: Installations in areas where power interruptions are frequent.  
Where user is likely to "play" with the room thermostat.  
All commercial installations.  
Installations where interconnecting tube length exceeds 50 ft.  
High rise applications.
- 7. Compressor Start Assist—PTC Type**

Solid state electrical device which gives a "soft" boost to the compressor at each start-up.

SUGGESTED USE: Installations with marginal power supply.  
Replacement installations with rapid pressure balance (RPB) expansion valve on indoor coil.  
Replacement installations with undersized interconnecting refrigerant tubes.
- 8. Compressor Start Assist—Capacitor/Relay Type**

Start capacitor and start relay gives "hard" boost to compressor motor at each start-up.

SUGGESTED USE: Installations where interconnecting tube length exceeds 50 ft.  
Installations where outdoor design temperature exceeds 105 F (40.6 C)  
Replacement installations with hard shut-off expansion valve on indoor coil.
- 9. Crankcase Heater**

An electric resistance heater which mounts to the base of the compressor to keep the lubricant warm during off cycles. Improves compressor lubrication on restart and minimizes chance of refrigerant slugging. May or may not include a thermostat control.

SUGGESTED USE: When interconnecting tube length exceeds 50 ft  
When unit will be operated below 55 F (12.8 C) outdoor air temperature. (Use with LOW AMBIENT OPERATION KIT, Item 2)  
All commercial installations.
- 10. Sound Blanket/Shield/Hood**

Wrap around sound attenuation blanket for the compressor. Reduces the sound level by about 0.2 bels.

SUGGESTED USE: Unit installed closer than 15 ft to quiet areas—bedrooms, etc.  
Unit installed between two houses less than 10 ft apart.
- 11. Thermostatic Expansion Valve (TXV) Kits**

A modulating flow control valve which meters refrigerant liquid flow rate into the evaporator in response to the superheat of the refrigerant gas leaving the evaporator. Kit includes valve, adapter tubes and external equalizer tube. Both hard shut off and RPB type valves are available.

SUGGESTED USE: For improved system performance in cooling mode for certain combinations of indoor and outdoor units. (Refer to ARI Unitary Directory)
- 12. Refrigerant Low Pressure Switch**

Auto reset SPST switch activated by refrigerant pressure on low side of refrigerant circuit. Cycles compressor off if refrigerant pressure drops to about 27 psig. Prevents indoor coil freeze-up due to loss of indoor air flow. Also, provides additional protection against compressor damage due to loss of refrigerant charge. To prevent rapid compressor recycling, COMPRESSOR SHORT CYCLE PROTECTOR (Item 6) can be used with this switch.

SUGGESTED USE: Where indoor coil is exposed to "dirty" air.  
All commercial installations. (Note: Standard on 3 phase units)
- 13. Refrigerant High Pressure Switch**

Auto reset SPST switch activated by refrigerant pressure on high side of refrigerant circuit. Cycles compressor off if refrigerant pressure rises to about 400 psig. Provides additional protection against compressor damage due to loss of outdoor air flow. To prevent rapid compressor recycling, COMPRESSOR SHORT CYCLE PROTECTOR (Item 6) can be used with this switch.

SUGGESTED USE: Installations exposed to very "dirty" outdoor air.  
Installations where condenser inlet air temperature exceeds 125 F (51.7 C).
- 14. Refrigerant Filter Drier**

A device for removing contaminants from refrigerant circulating in an air conditioner; one direction flow for air conditioners.

SUGGESTED USE: All field connected split system air conditioners.
- 15. Liquid Line Solenoid Valve (LLS)**

An electrically operated shut-off valve to be installed at the outdoor or indoor unit (depending on tubing configuration) and which stops and starts refrigerant liquid flow in response to compressor operation. Maintains a column of refrigerant liquid ready for action at next compressor operation cycle. **NOTE:** Compressor start assist — Capacitor/Relay type — (Item 8) must be used also.

SUGGESTED USE: For improved system performance in air conditioners for certain combinations of indoor and outdoor units. (Refer to ARI Unitary Directory)  
In certain long line applications (Refer to Long-Line Application Guideline).
- 16. Support Feet**

Four stick-on plastic feet which raise the unit 4 ins. above the mounting pad. This allows sand, dirt and other debris to be flushed from the unit base; minimizes corrosion.

SUGGESTED USE: Coastal installations.  
Windy areas or where debris is normally circulating.  
Rooftop installations.

# Dimensions

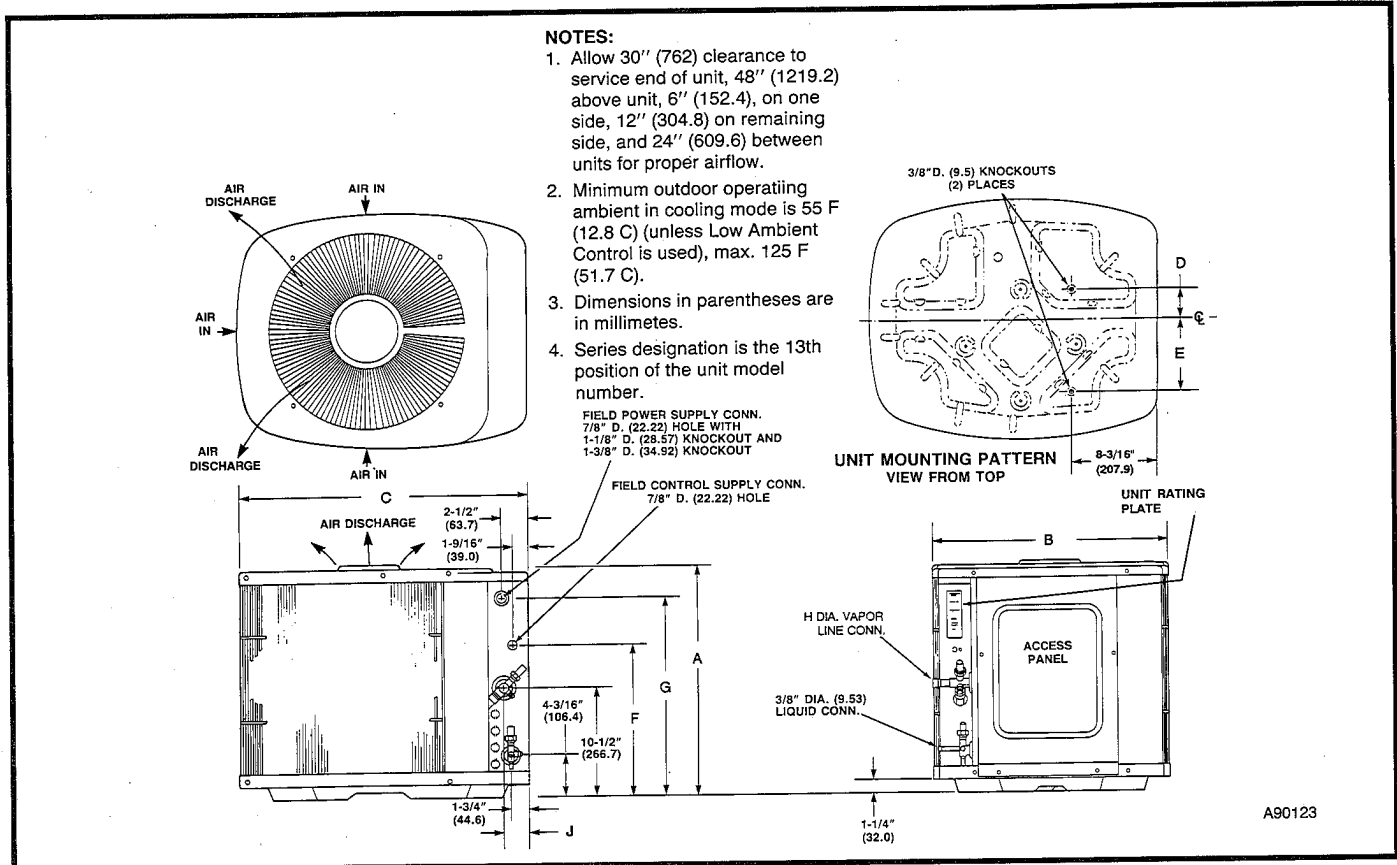

UNIT	SERIES	OPER. WGT.		A		B		C		D		E		F		G		H		J	
		LBS.	Kg.	IN.	(mm)	IN.	(mm)	IN.	(mm)	IN.	(mm)	IN.	(mm)	IN.	(mm)	IN.	(mm)	IN.	(mm)	IN.	(mm)
38TG014	0	132	59.8	21-7/8	555.6	22-1/2	571.5	27-1/2	698.5	2-7/8	71.4	7	176.1	13-3/8	339.7	17-7/8	454.0	5/8	15.88	2-3/8	60.3
38TG018	0	136	61.6	21-7/8	555.6	22-1/2	571.5	27-1/2	698.5	2-7/8	71.4	7	176.1	13-3/8	339.7	17-7/8	454.0	5/8	15.88	2-3/8	60.3
38TG024	0	140	63.4	21-7/8	555.6	22-1/2	571.5	27-1/2	698.5	2-7/8	71.4	7	176.1	13-3/8	339.7	17-7/8	454.0	5/8	15.88	2-3/8	60.3
38TG030	0	147	66.6	25-7/8	657.2	22-1/2	571.5	27-1/2	698.5	2-7/8	71.4	7	176.1	13-3/8	393.7	21-7/8	555.6	3/4	19.05	2-3/8	60.3
38TG036	1	177	80.2	31-7/8	809.6	22-1/2	571.5	27-1/2	698.5	2-7/8	71.4	7	176.1	21-1/2	546.1	27-7/8	708.0	3/4	19.05	2-3/8	60.3
38TG042	2	217	98.3	25-7/8	657.2	30	762.0	35	887.3	4	101.6	9-3/4	247.6	15-1/2	393.7	21-7/8	555.6	7/8	22.22	3	74.5
38TG048	1	224	101.5	25-7/8	657.2	30	762.0	35	887.3	4	101.6	9-3/4	247.6	15-1/2	393.7	21-7/8	555.6	7/8	22.22	3	74.5
38TG060	0.1	255	115.5	37-7/8	962.0	30	762.0	35	887.3	4	101.6	9-3/4	247.6	27-1/2	698.5	33-7/8	860.4	7/8	22.22	3	74.5

# Electrical data

OUTDOOR UNIT 38TG	V/PH	OPER VOLTS*		COMPR		FAN	MCA	75 C	75 C	MAX FUSE† OR HACR TYPE CKT BKR AMPS
		MAX	MIN	LRA	RLA	FLA		MIN. WIRE SIZE	MAX. LENGTH (Ft.)‡	
014-30	208/230/1	253	187	35.0	6.6	0.5	8.75	14	83	15
018-30				52.0	9.1	0.5	11.88	14	62	20
024-30				73.0	12.8	0.8	16.80	14	44	25
030-30				90.0	15.0	0.8	19.55	14	37	30
036-31				95.4	21.5	0.8	27.68	10	68	40
042-32				114.0	25.5	1.4	33.28	10	56	50
048-31				135.0	27.6	1.4	35.90	8	82	60
060-30				142.0	30.8	1.4	39.90	8	74	60
060-31				142.0	30.8	1.4	39.90	8	74	60
030-50	208/230/3	253	187	71.0	9.5	0.8	12.68	14	50	20
036-51				82.0	13.7	0.8	17.93	14	36	30
042-52				84.0	16.2	1.6	21.85	12	47	35
048-51				105.0	17.6	1.6	23.60	12	43	40
060-50				130.0	20.1	1.6	26.73	10	61	40
060-51				130.0	20.1	1.6	26.73	10	61	40
036-61	460/3	506	414	41.0	6.9	0.4	9.03	14	130	15
042-62				42.0	7.9	0.8	10.68	14	118	15
048-61				55.0	9.4	0.8	12.55	14	100	20
060-60				65.0	9.1	0.8	12.18	14	100	20
060-61				65.0	9.1	0.8	12.18	14	100	20

FLA —Full Load Amps

HACR—Heating, Air Conditioning, Refrigeration

LRA —Locked Rotor Amps

MCA —Minimum Circuit Amps

RLA —Rated Load Amps

\*Permissible limits of the voltage range at which unit will operate satisfactorily. Operation outside these limits may result in unit failure.

†Time-delay fuse.

‡Length shown is as measured one way along wire path between unit and service panel for maximum 2% voltage drop.

All motors/compressors contain internal overload protection. Copper wire must be used from service disconnect to unit. If other than uncoated (non-plated), 75 Degree C ambient, copper wire (solid wire for 10 AWG and smaller, stranded wire for larger than 10 AWG) is used, consult applicable tables of the National Electric Code (ANSI-NFPA 70).

**NOTE:** Control circuit is 24 v on all units and requires external power source.

# Performance data

OUTDOOR MODEL	INDOOR SECTION	INDOOR AIR CFM	TOT CAP	SEAS. EFF. W/ TDR.90† SEER	SEAS. EFF. W/O TDR.90† SEER	EFFIC. EER 3-Ph	SOUND RATING (BELS)
38TG-014-30	28RC015	520	13,400	8.60	8.30	—	7.8
	*28RDS015	520	13,400	8.70	8.50	—	
	40DQ014	520	12,300	8.20	8.00	—	
	28RC/RU018	520	13,100	8.70	8.50	—	
	28RDS/RNS018	520	13,400	8.70	8.50	—	
	28RH018	520	13,400	8.70	8.50	—	
	40AQ018	520	13,200	8.50	8.20	—	
	40DQ018	520	13,200	8.30	8.00	—	
	40RC018	520	13,400	8.50	8.20	—	
	38YR018	520	13,900	8.70	8.50	—	
	38YA018	520	14,200	—	9.00	—	
38TG-018-30	28RC/RU018	600	17,500	8.70	8.50	—	7.8
	*28RDS/RNS018	600	17,500	8.70	8.50	—	
	28RDS/RNS019	600	18,000	8.90	8.70	—	
	28RH018	600	17,500	8.90	8.50	—	
	40AQ018	600	17,200	8.40	8.20	—	
	40DQ018	600	17,300	8.40	8.20	—	
	40RC018	600	17,800	8.70	8.60	—	
	28HQS024	600	17,700	8.80	8.60	—	
	28RC/RU024	600	18,000	8.90	8.70	—	
	28RDS/RNS024	600	18,000	8.90	8.70	—	
	28RH024	600	18,000	8.90	8.70	—	
	28RM024	600	18,000	8.80	8.60	—	
	28SL024	600	17,700	8.80	8.60	—	
	40AQ024	600	17,600	8.60	8.50	—	
	40AQ025	600	17,800	8.80	8.60	—	
	40DQ024	600	17,500	8.70	8.50	—	
	40LT024	600	17,700	8.70	8.50	—	
	40RC024	600	17,500	8.80	8.60	—	
	40YR018	600	18,000	8.70	8.50	—	
	40YA018	600	18,400	—	9.00	—	
40YR024	600	18,200	8.90	8.60	—		
40YA024	600	18,400	—	9.00	—		

See notes on page 9.

# Performance data cont'd

OUTDOOR MODEL	INDOOR SECTION	INDOOR AIR CFM	TOT CAP	SEAS. EFF. W/ TDR.90† SEER	SEAS. EFF. W/O TDR.90† SEER	EFFIC. EER 3-Ph	SOUND RATING (BELS)
38TG-024-30	28HQS024	825	22,600	8.20	7.90	—	7.8
	28RC/RU024	800	23,200	8.20	8.00	—	
	*28RDS/RNS024	860	23,400	8.30	8.00	—	
	28RDS/RNS025	860	23,600	8.30	8.00	—	
	28RH024	860	23,400	8.30	8.00	—	
	28RM024	860	23,200	8.30	8.00	—	
	28SL024	860	23,000	8.20	7.90	—	
	40AQ024	850	21,800	7.80	7.50	—	
	40AQ025	850	22,600	8.00	7.70	—	
	40DQ024	860	22,600	8.00	7.70	—	
	40LT024	860	22,800	8.10	7.80	—	
	40RC024	860	23,400	8.30	8.00	—	
	28HQS030	860	23,400	8.30	8.00	—	
	28RC030,RC/RU130	860	23,600	8.50	8.10	—	
	28RDS030,RDS/RNS130	860	24,000	8.50	8.20	—	
	28RH030	860	24,000	8.50	8.20	—	
	28SL030	860	23,600	8.30	8.00	—	
	40AQ030	860	23,400	8.30	8.00	—	
	40AQ031	860	23,800	8.50	8.20	—	
	40DQ030	860	23,600	7.90	7.60	—	
	40RC030	860	23,400	8.20	7.90	—	
40YR024	860	23,400	8.30	8.00	—		
40YA024	860	24,000	—	8.50	—		
40YR030	860	23,500	8.50	8.20	—		
40YA030	860	24,200	—	8.50	—		
38TG-030-30 -50	28HQS030	1000	28,000	8.50	8.20	7.60	7.8
	28RC030,RC/RU130	1000	29,000	8.70	8.50	7.90	
	*28RDS030,RDS/RNS130	1000	29,200	8.70	8.50	7.85	
	28RH030	1000	29,200	8.70	8.50	7.85	
	28SL030	1000	27,800	8.50	8.80	7.65	
	40AQ030	1000	27,800	8.20	8.00	7.40	
	40AQ031	1000	29,000	8.40	8.20	7.65	
	40DQ030	1000	28,200	8.30	8.10	7.50	
	40RC030	1000	28,200	8.30	8.10	7.50	
	28HQS/VQS036	1000	28,600	8.50	8.30	7.65	
	28RC/RU036,RC136	1000	29,400	8.70	8.50	7.85	
	28RDS/RNS036,RDS136	1000	29,400	8.70	8.50	7.85	
	28RH036	1000	29,400	8.70	8.50	7.85	
	28RM036	1000	28,400	8.50	8.30	7.70	
	28SL036	1000	28,800	8.60	8.40	7.75	
	40AQ036	1000	28,600	8.50	8.30	7.65	
	40LT036	1000	29,000	8.50	8.30	7.70	
	40YR030	1000	29,000	8.50	8.30	7.65	
40YA030	1000	29,200	—	8.70	7.65		
40YR036	1000	29,000	8.50	8.30	7.60		
40YA036	1000	30,000	—	8.70	7.70		
38TG-036-31 -51 -61	28HQS/VQS036	1200	34,800	8.50	8.40	7.60	8.0
	28RC/RU036,RC136	1200	35,200	8.70	8.50	7.75	
	*28RDS/RNS036,RDS136	1200	35,200	8.70	8.50	7.85	
	38RH036	1200	35,200	8.70	8.50	7.70	
	28RM036	1200	34,400	8.50	8.30	7.55	
	28SL036	1200	35,000	8.70	8.50	7.70	
	40AQ036	1200	34,400	8.30	8.00	7.25	
	40LT036	1200	34,800	8.50	8.30	7.55	
	28HQS/VQS042	1200	35,000	8.70	8.50	7.70	
	28RC/RU042	1350	35,200	8.60	8.40	7.60	
	28RC/RU142	1350	35,200	8.60	8.40	7.60	
	28RC/RU242	1200	36,000	8.70	8.50	7.70	
	28RDS/RNS042	1200	35,200	8.70	8.50	7.70	
	28RDS/RNS142	1200	35,200	8.70	8.50	7.75	
	28RDS/RNS242	1200	36,000	8.80	8.60	7.80	
	28RDS/RNS043	1200	36,000	8.80	8.60	7.80	
	28RDS/RNS143	1200	36,000	8.80	8.60	7.80	
	28RH042	1200	35,200	8.70	8.50	7.70	
	28SL042	1200	35,200	8.75	8.55	7.75	
	40QBS/QHS042	1200	35,600	8.50	8.30	7.55	
40QBS/QHS043	1200	35,800	8.70	8.50	7.70		
40YR036	1200	34,600	8.50	8.20	7.25		
40YA036	1200	35,600	—	8.50	7.35		
40YR/YRM042	1200	35,600	8.70	8.50	7.45		
40YA/YAM042	1200	36,000	—	9.00	7.75		
38TG-042-32 -52 -62	28HQS/VQS042	1500	41,000	8.50	8.00	6.80	7.8
	28RC/RU042	1575	40,500	8.50	8.00	6.80	
	28RC/RU142	1575	40,500	8.45	8.00	6.80	
	28RC/RU242	1400	42,000	8.60	8.20	7.00	
	*28RDS/RNS042	1575	40,500	8.50	8.00	7.15	
	28RDS/RNS142	1575	40,500	8.50	8.00	6.75	
28RDS/RNS242	1400	41,500	8.60	8.20	6.95		

See notes on page 9.



# Performance data cont'd

OUTDOOR MODEL	INDOOR SECTION	INDOOR AIR CFM	TOT CAP	SEAS. EFF. W/ TDR.90† SEER	SEAS. EFF. W/O TDR.90† SEER	EFFIC. EER 3-Ph	SOUND RATING (BELS)
38TG-042-32 -52 -62	28RDS/RNS043	1575	42,000	8.70	8.30	7.00	8.0
	28RDS/RNS143	1575	42,000	8.70	8.30	7.00	
	28RH042	1575	40,500	8.50	8.00	6.75	
	28SL042	1575	41,000	8.50	8.00	6.75	
	40QBS/QHS042	1575	41,000	8.30	8.00	6.75	
	40QBS/QHS043	1575	42,000	8.40	8.00	6.75	
	28HQS/VQS048	1500	41,500	8.50	8.10	6.85	
	28RC048	1575	42,000	8.50	8.20	7.00	
	28RC/RU148	1575	42,000	8.50	8.20	7.00	
	28RC248	1575	42,000	8.60	8.30	7.05	
	28RDS048	1575	41,500	8.50	8.20	6.95	
	28RDS/RNS148	1575	41,500	8.50	8.20	6.95	
	28RDS248	1575	42,000	8.60	8.20	6.96	
	28RDS049	1575	42,000	8.70	8.30	7.00	
	28RH048	1575	41,500	8.50	8.20	6.95	
	28RM048	1575	41,500	8.50	8.20	6.90	
	28SL049	1575	42,000	8.50	8.30	7.00	
	40LT048	1575	41,500	8.20	8.00	6.75	
	40QBS/QHS048	1575	41,500	8.30	8.00	6.75	
	40QBS/QHS049	1575	42,000	8.40	8.10	6.85	
	40YR/YRM042	1515	40,500	8.50	8.00	6.95	
	40YA/YAM042	1550	42,000	—	8.50	7.20	
	40YR/YRM048	1550	41,500	8.50	8.10	7.10	
	40YA/YAM048	1550	42,000	—	8.50	7.30	
38TG-048-31 -51 -61	28HQS/VQS048	1500	45,500	8.60	8.30	7.75	8.4
	28RC048	1750	47,000	8.60	8.30	7.85	
	28RC/RU148	1750	47,000	8.60	8.30	7.85	
	28RC248	1600	48,000	8.80	8.50	8.05	
	*28RDS048	1758	47,000	8.60	8.30	7.85	
	28RDS/RNS148	1750	47,000	8.60	8.30	7.75	
	28RDS248	1600	47,500	8.80	8.50	7.95	
	28RDS049	1750	48,000	8.80	8.50	8.00	
	28RH048	1750	47,000	8.60	8.30	7.75	
	28RM048	1600	46,500	8.70	8.40	7.80	
	28SL049	1750	48,000	8.80	8.50	8.00	
	40LT048	1750	47,000	8.40	8.10	7.55	
	40QBS/QHS048	1750	47,500	8.50	8.20	7.65	
	40QBS/QHS049	1750	48,000	8.60	8.30	7.80	
	28HQS/VQS060	1600	48,000	8.80	8.50	7.95	
	28RC/RU057	1750	48,000	8.80	8.50	8.00	
	28RC/RU060	1750	48,000	8.70	8.40	7.85	
	28RDS/RNS057	1750	48,000	8.80	8.50	8.00	
	28RDS/RNS060	1750	48,000	8.80	8.50	7.95	
	28RDS/RNS061	1750	48,000	8.90	8.60	8.05	
	28RH060	1750	48,000	8.80	8.50	8.00	
	28SL061	1750	48,000	8.90	8.60	8.05	
	40LT060	1750	48,000	8.60	8.30	7.80	
	40QBS/QHS060	1750	48,000	8.30	8.00	7.50	
40QBS/QHS062	1750	48,000	8.50	8.20	7.70		
40QBS/QHS063	1750	48,000	8.60	8.30	7.75		
40YR/YRM048	1750	47,000	8.50	8.30	7.75		
40YA/YAM048	1750	48,000	—	8.70	7.75		
40YR/YRM060	1750	48,000	8.50	8.00	7.55		
40YAM060	1750	48,500	—	9.00	7.70		
38TG-060-30, -31 -50, -51 -60, -61	28HQS/VQS060	1600	55,000	8.70	8.50	7.80	8.4
	28RC/RU057	1850	56,500	8.50	8.40	7.85	
	28RC/RU060	2175	57,000	8.60	8.50	7.90	
	28RDS/RNS057	1850	56,000	8.60	8.50	7.85	
	28RDS/RNS060	2175	57,000	8.60	8.50	7.85	
	*28RDS/RNS061	2175	58,000	8.60	8.50	7.90	
	28RH060	1850	56,000	8.60	8.50	7.85	
	28SL061	2000	58,000	8.80	8.60	7.90	
	40LT060	2000	56,000	8.50	8.30	7.65	
	40QBS/QHS060	2100	57,000	8.20	8.00	7.35	
	40QBS/QHS062	2100	57,500	8.50	8.30	7/65	
	40QBS/QHS063	2100	58,500	8.50	8.40	7.75	
	40QBS005 & 315016-402	2100	57,500	8.60	8.50	7.90	
	40YR/YRM060	2000	55,500	8.50	8.20	7.55	
40YAM060	2000	57,500	—	8.70	7.80		

\*Tested Combination

†See TDR .90 TABLE. A 90 second time delay function can be met by use of external devices, or the time delay feature incorporated into specified furnaces, heaters and thermostats.

- NOTES:**
1. Ratings are net values reflecting the effects of circulating fan motor heat. Supplemental electric heat is not included.
  2. Tested outdoor/indoor combinations have been tested in accordance with DOE test procedures for central air conditioners. Ratings for other combinations are determined under DOE computer simulation procedures.
  3. Determine actual CFM values obtainable for your system by referring to fan performance data in fan coil or furnace coil literature.
  4. The dashes (—) appearing in the SEAS. EFF. W/TDR.90+ SEER column indicate no improvement in efficiency due to factory installed hard shut-off TXV (40YA fan coils) or liquid line solenoid shipped with unit.

TDR .90 TABLE

METHOD	PART/MODEL NUMBER
Indoor Fan Time Delay Relay	38EH900001 38TH900001
Furnaces	58SSC/58DHC, 58SX, 58DX, 58SXB
Electric Heater	40AQ904170 5 KW 40AQ904180 7.5 KW
Packages	40AQ904190 10 KW 40AQ904200 15 KW 40AS901010 Cooling Control
Thermostats	Not Available At This Time

NOTE: In most cases, only one of the above should be used to achieve TDR function. More than one of the methods listed above in a system may cause degradation in performance.

# Detailed Cooling Capacities\*

Evaporator Air		CONDENSER ENTERING AIR TEMPERATURES °F															
		85			95			105			115			125			
		CFM	E W B	Capacity MBtu/h†		Total System KW**	Capacity MBtu/h†		Total System KW**	Capacity MBtu/h†		Total System KW**	Capacity MBtu/h†		Total System KW**	Capacity MBtu/h†	
Total	Sens†			Total	Sens†	Total	Sens†	Total	Sens†	Total	Sens†	Total	Sens†	Total	Sens†		
<b>38TG014-30 Outdoor Section With 28RDS015 Indoor Section</b>																	
410	72	15.2	7.44	1.49	14.4	7.14	1.57	13.5	6.82	1.65	12.6	6.50	1.74	11.7	6.18	1.83	
	67	13.7	9.32	1.44	13.0	9.00	1.51	12.2	8.68	1.60	11.3	8.34	1.68	10.5	8.01	1.76	
	62	12.4	11.1	1.39	11.7	10.8	1.46	11.0	10.4	1.54	10.2	9.97	1.62	9.46	9.44	1.70	
	57	11.8	11.8	1.37	11.3	11.3	1.45	10.7	10.7	1.53	10.1	10.1	1.62	9.44	9.44	1.70	
465	72	15.5	7.75	1.52	14.6	7.44	1.60	13.7	7.13	1.69	12.8	6.80	1.77	11.9	6.47	1.86	
	67	14.0	9.86	1.47	13.2	9.53	1.55	12.4	9.20	1.63	11.5	8.86	1.71	10.6	8.50	1.79	
	62	12.7	11.8	1.42	11.9	11.4	1.50	11.2	11.0	1.58	10.5	10.5	1.66	9.77	9.77	1.74	
	57	12.3	12.3	1.41	11.7	11.7	1.49	11.1	11.1	1.57	10.4	10.4	1.66	9.77	9.77	1.74	
520	72	15.7	8.05	1.55	14.8	7.73	1.63	13.9	7.41	1.72	13.0	7.09	1.81	12.0	6.76	1.89	
	67	14.2	10.4	1.50	13.4	10.0	1.58	12.5	9.70	1.66	11.7	9.34	1.74	10.7	8.97	1.82	
	62	12.9	12.4	1.45	12.2	12.0	1.53	11.4	11.4	1.61	10.7	10.7	1.70	10.0	10.0	1.78	
	57	12.6	12.6	1.44	12.0	12.0	1.52	11.4	11.4	1.61	10.7	10.7	1.70	10.0	10.0	1.78	

Multipliers for Determining the Performance With Other Indoor Sections

Indoor Section	Size	Cooling		Indoor Section	Size	Cooling	
		Capacity	Power			Capacity	Power
28RC	015	1.00	1.00	40AQ	018	0.99	1.03
28RC/RU	018	0.98	0.99	40DQ	014	0.92	1.01
28RDS	015	1.00	1.00		018	0.99	1.03
28RDS/RNS	018	1.00	1.00	40RC	018	1.00	0.99
28RH	018	1.00	1.00	40YR	018	1.04	1.02
				40YA	018	1.06	1.02

38TG018-30 Outdoor Section With 28RDS/RNS018 Indoor Section

525	72	19.9	9.66	2.10	19.0	9.28	2.19	17.9	8.90	2.29	16.9	8.52	2.40	15.9	8.15	2.52
	67	18.1	12.0	2.00	17.1	11.6	2.09	16.2	11.2	2.19	15.2	10.8	2.29	14.3	10.4	2.40
	62	16.3	14.3	1.91	15.4	13.8	1.99	14.5	13.4	2.08	13.6	12.9	2.18	12.8	12.4	2.29
	57	15.3	15.3	1.86	14.6	14.6	1.95	13.9	13.9	2.05	13.2	13.2	2.15	12.6	12.6	2.27
600	72	20.4	10.1	2.16	19.3	9.68	2.25	18.3	9.30	2.35	17.3	8.92	2.46	16.2	8.54	2.58
	67	18.5	12.7	2.05	17.5	12.3	2.14	16.5	11.9	2.24	15.5	11.5	2.34	14.6	11.1	2.45
	62	16.7	15.2	1.96	15.8	14.7	2.04	14.8	14.2	2.14	14.0	13.7	2.24	13.1	13.1	2.34
	57	15.9	15.9	1.92	15.2	15.2	2.01	14.5	14.5	2.11	13.8	13.8	2.22	13.1	13.1	2.34
675	72	20.7	10.4	2.21	19.6	10.1	2.30	18.6	9.67	2.40	17.5	9.28	2.51	16.4	8.91	2.63
	67	18.8	13.4	2.10	17.8	12.9	2.19	16.8	12.5	2.29	15.8	12.1	2.39	14.7	11.7	2.50
	62	17.0	16.0	2.01	16.1	15.5	2.10	15.2	14.9	2.19	14.3	14.2	2.29	13.5	13.5	2.41
	57	16.5	16.5	1.98	15.7	15.7	2.08	15.0	15.0	2.18	14.2	14.2	2.29	13.5	13.5	2.41

Multipliers for Determining the Performance With Other Indoor Sections

Indoor Section	Size	Cooling		Indoor Section	Size	Cooling	
		Capacity	Power			Capacity	Power
28HQS	024	1.01	1.01	40AQ	018	0.98	1.02
28RC/RU	018	1.00	0.98		024	1.01	1.02
	024	1.03	0.99		025	1.02	1.03
28RDS/RNS	018	1.00	1.00	40DQ	018	0.99	1.03
	019	1.03	1.02		024	1.00	1.01
	024	1.03	1.02	40LT	024	1.01	1.02
28RH	018	1.00	1.00	40RC	018	1.02	0.99
	024	1.03	1.02		024	1.02	1.03
28RM	024	1.03	1.02	40YR	018	1.00	1.02
28SL	024	1.01	1.01		024	1.00	1.04
					40YA	018	1.00
				024	1.00	1.03	

See notes on page 14.

# Detailed Cooling Capacities\* cont'd

Evaporator		CONDENSER ENTERING AIR TEMPERATURES °F														
Air		85			95			105			115			125		
CFM	E W B	Capacity MBtu/h†		Total System KW**	Capacity MBtu/h†		Total System KW**	Capacity MBtu/h†		Total System KW**	Capacity MBtu/h†		Total System KW**	Capacity MBtu/h†		Total System KW**
		Total	Sens†		Total	Sens†		Total	Sens†		Total	Sens†		Total	Sens†	
<b>38TG024-30 Outdoor Section With 28RDS/RNS024 Indoor Section</b>																
700	72	26.6	12.9	3.08	25.1	12.4	3.22	23.7	11.9	3.37	22.2	11.3	3.53	20.8	10.8	3.69
	67	24.1	16.1	2.93	22.7	15.6	3.06	21.4	15.0	3.20	20.0	14.5	3.35	18.7	13.9	3.51
	62	21.7	19.2	2.79	20.5	18.6	2.92	19.2	17.9	3.05	18.0	17.3	3.19	16.7	16.5	3.34
	57	20.5	20.5	2.72	19.5	19.5	2.85	18.6	18.6	3.00	17.6	17.6	3.15	16.5	16.5	3.33
800	72	27.1	13.5	3.15	25.6	13.0	3.30	24.1	12.4	3.45	22.6	11.9	3.60	21.1	11.4	3.78
	67	24.6	17.1	3.00	23.2	16.5	3.14	21.8	16.0	3.28	20.4	15.4	3.42	19.0	14.9	3.58
	62	22.2	20.5	2.86	21.0	19.8	2.99	19.7	19.1	3.13	18.5	18.3	3.27	17.3	17.3	3.43
	57	21.4	21.4	2.81	20.4	20.4	2.96	19.4	19.4	3.10	18.3	18.3	3.26	17.3	17.3	3.43
900	72	27.6	14.1	3.22	26.0	13.5	3.37	24.4	12.9	3.52	22.9	12.4	3.68	21.4	11.9	3.84
	67	25.0	18.0	3.07	23.5	17.5	3.20	22.1	16.9	3.34	20.6	16.3	3.49	19.2	15.7	3.65
	62	22.7	21.6	2.93	21.4	20.9	3.06	20.1	20.0	3.20	19.0	19.0	3.35	17.9	17.9	3.53
	57	22.2	22.2	2.90	21.1	21.1	3.05	20.0	20.0	3.19	19.0	19.0	3.36	17.9	17.9	3.53

Multipliers for Determining the Performance With Other Indoor Sections

Indoor Section	Size	Cooling		Indoor Section	Size	Cooling		
		Capacity	Power			Capacity	Power	
28HQS	024	0.97	0.98	40AQ	024	0.93	0.98	
	030	1.00	1.01		025	0.97	1.00	
28RC	030	1.01	1.01		030	1.00	1.01	
28RC/RU	024	1.00	1.00		40DQ	031	1.02	1.04
	130	1.03	1.01	024		0.97	0.99	
28RDS	030	1.03	1.02	030	0.97	1.01		
28RDS/RNS	024	1.00	1.00	40LT	024	0.97	0.99	
	025	1.01	1.01		40RC	024	1.00	1.01
	130	1.03	1.02			030	1.01	1.04
28RH	024	1.00	1.00	40YR	024	1.00	1.01	
	030	1.03	1.02		030	1.00	1.04	
28RM	024	0.99	1.00	40YA	024	1.03	1.03	
28SL	024	0.98	0.99		030	1.03	1.04	
	030	1.01	1.01					

38TG030-30 Outdoor Section With 28RDS030,28RDS/RNS130 Indoor Section

875	72	33.5	16.5	3.67	31.7	15.9	3.82	30.0	15.2	3.99	28.2	14.6	4.16	26.4	13.9	4.35
	67	30.3	20.7	3.47	28.6	20.1	3.62	27.0	19.4	3.77	25.3	18.7	3.94	23.6	18.0	4.12
	62	27.4	24.7	3.30	25.9	24.0	3.44	24.3	23.2	3.59	22.9	22.3	3.75	21.4	21.3	3.93
	57	26.2	26.2	3.23	25.0	25.0	3.39	23.8	23.8	3.55	22.6	22.6	3.73	21.3	21.3	3.93
1000	72	34.1	17.3	3.77	32.3	16.6	3.92	30.5	16.0	4.08	28.6	15.3	4.26	26.8	14.7	4.45
	67	30.9	22.1	3.57	29.2	21.4	3.71	27.5	20.7	3.87	25.7	20.0	4.03	24.0	19.3	4.21
	62	28.0	26.4	3.40	26.5	25.6	3.54	25.0	24.6	3.69	23.5	23.5	3.86	22.2	22.2	4.06
	57	27.3	27.3	3.35	26.1	26.1	3.51	24.8	24.8	3.68	23.5	23.5	3.86	22.2	22.2	4.05
1125	72	34.6	18.0	3.85	32.8	17.4	4.00	30.9	16.7	4.17	29.0	16.1	4.34	27.1	15.4	4.53
	67	31.4	23.3	3.65	29.6	22.6	3.79	27.9	21.9	3.95	26.1	21.2	4.11	24.3	20.5	4.29
	62	28.6	27.9	3.49	27.1	26.9	3.63	25.6	25.6	3.79	24.3	24.3	3.98	22.9	22.9	4.17
	57	28.3	28.3	3.46	27.0	27.0	3.62	25.6	25.6	3.79	24.3	24.3	3.98	22.9	22.9	4.17

Multipliers for Determining the Performance With Other Indoor Sections

Indoor Section	Size	Cooling		Indoor Section	Size	Cooling	
		Capacity	Power			Capacity	Power
28HQS	030	0.96	0.98	28RM	036	0.97	0.99
28HQS/VQS	036	0.98	1.00		28SL	030	0.95
28RC	030	0.99	0.99	40AQ		036	0.99
	136	1.01	1.00		030	0.95	1.00
28RC/RU	130	0.99	0.99	40DQ	031	0.99	1.02
	036	1.01	1.00		036	0.98	1.00
28RDS	030	1.00	1.00	40LT	030	0.97	1.01
	136	1.01	1.00		40RC	036	0.99
28RDS/RNS	130	1.00	1.00	40YR		030	0.97
	036	1.01	1.00		036	0.99	1.02
28RH	030	1.00	1.00	40YA	030	1.00	1.01
	036	1.01	1.01		036	1.03	1.04

See notes on page 14.

# Detailed Cooling Capacities\* cont'd

Evaporator Air			CONDENSER ENTERING AIR TEMPERATURES °F														
			85			95			105			115			125		
			CFM	E W B	Capacity MBtu/h†		Total System	Capacity MBtu/h†		Total System	Capacity MBtu/h†		Total System	Capacity MBtu/h†		Total System	Capacity MBtu/h†
Total	Sens‡	KW**			Total	Sens‡	KW**	Total	Sens‡	KW**	Total	Sens‡	KW**	Total	Sens‡	KW**	
<b>38TG036-31 Outdoor Section With 28RDS/RNS036 Indoor Section</b>																	
1050	72	40.2	19.7	4.43	37.9	18.8	4.68	35.6	17.9	4.93	33.1	17.1	5.17	30.6	16.2	5.40	
	67	36.7	24.7	4.22	34.5	23.8	4.46	32.3	22.9	4.70	30.1	22.0	4.92	27.7	21.0	5.13	
	62	33.4	29.5	4.03	31.4	28.5	4.26	29.4	27.5	4.48	27.3	26.3	4.70	25.0	24.9	4.91	
	57	31.7	31.7	3.93	30.1	30.1	4.17	28.5	28.5	4.42	26.8	26.8	4.66	24.9	24.9	4.89	
1200	72	41.0	20.5	4.54	38.6	19.7	4.79	36.2	18.8	5.04	33.6	17.9	5.28	31.1	17.0	5.51	
	67	37.4	26.2	4.33	35.2	25.3	4.57	32.9	24.4	4.80	30.5	23.4	5.03	28.1	22.4	5.24	
	62	34.1	31.5	4.14	32.1	30.4	4.37	30.1	29.2	4.59	28.0	27.9	4.82	25.9	25.9	5.05	
	57	33.0	33.0	4.07	31.4	31.4	4.32	29.7	29.7	4.57	27.9	27.9	4.81	25.9	25.9	5.05	
1350	72	41.6	21.4	4.63	39.1	20.5	4.89	36.6	19.6	5.14	34.0	18.7	5.37	31.4	17.8	5.61	
	67	38.0	27.6	4.43	35.7	26.7	4.66	33.3	25.7	4.90	30.9	24.8	5.12	28.4	23.8	5.34	
	62	34.8	33.2	4.24	32.8	32.0	4.47	30.7	30.6	4.71	28.8	28.8	4.95	26.8	26.8	5.19	
	57	34.1	34.1	4.20	32.4	32.4	4.45	30.6	30.6	4.70	28.8	28.8	4.95	26.8	26.8	5.19	

Multipliers for Determining the Performance With Other Indoor Sections

Indoor Section	Size	Cooling		Indoor Section	Size	Cooling	
		Capacity	Power			Capacity	Power
28HQS/VQS	036	0.99	0.99	28RH	036	1.00	1.00
	042	0.99	1.00		042	1.00	1.00
28RC	136	1.00	1.00	28RM	036	0.98	0.98
28RC/RU	036	1.00	1.00	28SL	036	0.99	0.99
	042/142	1.00	1.01		042	1.00	1.00
	242	1.02	1.01	40AQ	036	0.98	0.99
28RDS	136	1.00	1.00	40LT	036	0.99	1.00
28RDS/RNS	036	1.00	1.00	40QBS/QHS	042	1.01	1.01
	042/142	1.00	1.00		043	1.02	1.02
	242	1.02	1.01	40YR	036	0.98	1.02
	043/143	1.02	1.02	40YR/YRM	042	1.01	1.03
				40YA	036	1.01	1.05
			40YA/YAM	042	1.02	1.06	

38TG042-32 Outdoor Section With 28RDS/RNS042 Indoor Section

1225	72	46.1	22.4	5.21	43.2	21.4	5.45	40.4	20.3	5.68	37.4	19.2	5.88	34.4	18.2	6.06
	67	41.8	28.0	4.97	39.2	26.9	5.19	36.5	25.8	5.40	33.8	24.7	5.58	30.8	23.5	5.75
	62	37.9	33.4	4.74	35.4	32.2	4.95	32.9	30.9	5.14	30.3	29.4	5.31	27.4	27.4	5.48
	57	35.6	35.6	4.62	33.8	33.8	4.84	31.8	31.8	5.05	29.7	29.7	5.27	27.4	27.4	5.48
1400	72	47.0	23.4	5.34	44.1	22.3	5.57	41.1	21.2	5.80	38.0	20.2	6.01	34.9	19.1	6.19
	67	42.7	29.7	5.10	40.0	28.5	5.32	37.2	27.4	5.53	34.4	26.3	5.71	31.3	25.1	5.88
	62	38.7	35.5	4.87	36.2	34.2	5.08	33.7	32.8	5.27	31.1	31.0	5.45	28.5	28.5	5.65
	57	37.1	37.1	4.78	35.2	35.2	5.01	33.1	33.1	5.23	31.0	31.0	5.44	28.5	28.5	5.65
1550	72	47.6	24.1	5.44	44.6	23.1	5.67	41.5	22.0	5.90	38.4	20.9	6.11	35.2	19.8	6.29
	67	43.3	31.0	5.20	40.5	29.8	5.42	37.6	28.7	5.63	34.7	27.6	5.81	31.6	26.3	5.97
	62	39.3	37.2	4.97	36.8	35.7	5.18	34.2	34.0	5.38	31.9	31.9	5.58	29.4	29.4	5.79
	57	38.3	38.3	4.91	36.2	36.2	5.15	34.1	34.1	5.37	31.9	31.9	5.58	29.4	29.4	5.79
1575	72	47.7	24.3	5.45	44.7	23.2	5.69	41.6	22.1	5.92	38.5	21.0	6.12	35.3	19.9	6.30
	67	43.4	31.2	5.21	40.6	30.0	5.44	37.7	28.9	5.64	34.8	27.8	5.83	31.7	26.5	5.98
	62	39.4	37.5	4.99	36.9	36.0	5.20	34.4	34.2	5.40	32.0	32.0	5.60	29.5	29.5	5.81
	57	38.5	38.5	4.93	36.4	36.4	5.17	34.2	34.2	5.39	32.0	32.0	5.60	29.5	29.5	5.81

Multipliers for Determining the Performance With Other Indoor Sections

Indoor Section	Size	Cooling		Indoor Section	Size	Cooling	
		Capacity	Power			Capacity	Power
28HQS/VQS	042	1.01	1.00	28RH	042	1.00	1.00
	048	1.02	1.00		048	1.02	1.01
28RC	048	1.04	1.01	28RM	048	1.02	1.01
	248	1.04	1.01		28SL	042	1.01
28RC/RU	042/142	1.00	1.01	40LT		049	1.04
	242	1.04	1.01		048	1.02	1.01
	148	1.04	1.00	40QBS/QHS	042	1.01	1.02
28RDS	048	1.02	1.01		043	1.04	1.03
	248	1.04	1.02		048	1.02	1.03
	049	1.04	1.02		049	1.04	1.04
28RDS/RNS	042/142	1.00	1.00		40YR/YRM	042	1.00
	242	1.02	1.00	048		1.02	1.16
28RDS/RNS	043/143	1.04	1.02	40YA/YAM	042	1.04	1.18
					048	1.04	1.18

See notes on page 14.

# Detailed Cooling Capacities\* cont'd

Evaporator			CONDENSER ENTERING AIR TEMPERATURES °F														
Air			85			95			105			115			125		
CFM	E W B		Capacity MBtu/h†		Total System	Capacity MBtu/h†		Total System	Capacity MBtu/h†		Total System	Capacity MBtu/h†		Total System	Capacity MBtu/h†		Total System
			Total	Sens‡	KW**	Total	Sens‡	KW**	Total	Sens‡	KW**	Total	Sens‡	KW**	Total	Sens‡	KW**
<b>38TG048-31 Outdoor Section With 28RDS048 Indoor Section</b>																	
1400	72		54.1	26.4	5.87	51.0	25.3	6.18	47.8	24.1	6.48	44.6	22.9	6.75	41.3	21.8	7.00
	67		49.2	33.1	5.62	46.3	31.9	5.90	43.3	30.7	6.17	40.4	29.5	6.42	37.4	28.3	6.64
	62		44.6	39.5	5.37	41.9	38.2	5.64	39.3	36.8	5.88	36.6	35.3	6.11	33.8	33.6	6.33
	57		42.2	42.2	5.24	40.1	40.1	5.52	38.1	38.1	5.79	35.9	35.9	6.05	33.6	33.6	6.31
1600	72		55.2	27.6	6.01	51.9	26.4	6.33	48.6	25.2	6.62	45.3	24.0	6.89	41.9	22.9	7.13
	67		50.2	35.1	5.75	47.2	33.8	6.04	44.1	32.6	6.31	41.1	31.4	6.56	38.0	30.2	6.78
	62		45.6	42.1	5.50	42.9	40.6	5.78	40.2	39.1	6.03	37.5	37.3	6.27	35.0	35.0	6.51
	57		44.0	44.0	5.42	41.8	41.8	5.71	39.6	39.6	5.99	37.3	37.3	6.26	35.0	35.0	6.51
1800	72		56.0	28.7	6.14	52.7	27.5	6.45	49.2	26.3	6.74	45.8	25.1	7.02	42.4	23.9	7.26
	67		51.0	36.9	5.87	47.9	35.7	6.16	44.7	34.4	6.44	41.6	33.2	6.68	38.3	31.9	6.91
	62		46.5	44.4	5.63	43.7	42.8	5.91	41.0	40.9	6.18	38.5	38.5	6.44	36.0	36.0	6.70
	57		45.5	45.5	5.58	43.2	43.2	5.88	40.9	40.9	6.17	38.5	38.5	6.44	36.0	36.0	6.70

Multipliers for Determining the Performance With Other Indoor Sections

Indoor Section	Size	Cooling		Indoor Section	Size	Cooling	
		Capacity	Power			Capacity	Power
28HQS/VQS	048	0.97	0.97	28RH	048	1.00	1.00
	060	1.02	1.00		060	1.02	1.02
28RC	048	1.00	1.00	28RM	048	0.99	0.99
	248	1.02	1.00		28SL	049	1.02
28RC/RU	148	1.00	1.00	40LT		061	1.02
	057	1.02	1.02		048	1.02	1.01
	060	1.02	1.01		060	1.02	1.03
28RDS	048	1.00	1.00	40QBS/QHS	048	1.01	1.03
	248	1.01	1.00		049	1.02	1.04
	049	1.02	1.02		060	1.02	1.08
28RDS/RNS	148	1.00	1.00	40YR/YRM	062	1.02	1.07
	057	1.02	1.02		063	1.02	1.08
	060	1.02	1.03		048	1.00	1.08
	061	1.02	1.02		060	1.02	1.02
					40YA/YAM	048	1.02
			40YAM	060	1.02	1.07	

38TG060-30 Outdoor Section With 28RDS/RNS061 Indoor Section

1750	72	65.7	32.1	6.98	62.0	30.8	7.38	58.3	29.4	7.77	54.5	28.0	8.13	50.7	26.6	8.49
	67	59.7	40.3	6.69	56.3	38.9	7.06	52.8	37.4	7.41	49.4	36.0	7.75	45.9	34.7	8.08
	62	54.0	48.2	6.40	50.8	46.6	6.74	47.6	44.9	7.07	44.5	43.1	7.38	41.4	41.1	7.68
	57	50.7	50.7	6.24	48.4	48.4	6.60	46.0	46.0	6.95	43.5	43.5	7.30	41.1	41.1	7.65
2000	72	67.0	33.6	7.16	63.2	32.2	7.56	59.3	30.8	7.94	55.3	29.4	8.31	51.4	28.0	8.67
	67	60.9	42.7	6.86	57.4	41.3	7.23	53.8	39.8	7.59	50.2	38.4	7.93	46.6	37.0	8.25
	62	55.1	51.3	6.56	51.8	49.5	6.91	48.6	47.5	7.24	45.4	45.2	7.56	42.5	42.5	7.90
	57	52.8	52.8	6.45	50.3	50.3	6.82	47.7	47.7	7.19	45.1	45.1	7.55	42.5	42.5	7.90
2250	72	68.0	34.9	7.31	64.1	33.5	7.72	60.1	32.1	8.10	56.0	30.7	8.47	51.9	29.2	8.82
	67	61.9	45.0	7.01	58.2	43.6	7.39	54.5	42.1	7.74	50.8	40.6	8.09	47.0	39.2	8.42
	62	56.1	53.9	6.71	52.7	51.8	7.07	49.4	49.4	7.41	46.5	46.5	7.76	43.7	43.7	8.12
	57	54.6	54.6	6.65	52.0	52.0	7.02	49.2	49.2	7.39	46.5	46.5	7.77	43.7	43.7	8.12

Multipliers for Determining the Performance With Other Indoor Sections

Indoor Section	Size	Cooling		Indoor Section	Size	Cooling	
		Capacity	Power			Capacity	Power
28HQS/VQS	060	0.95	0.94	40LT	060	0.97	0.97
28RC/RU	057	0.97	0.97	40QBS & 315016-402	005	0.99	1.03
	060	0.98	0.99		40QBS/QHS	060	0.98
28RDS/RNS	057	0.97	0.96	062		0.99	1.02
	060	0.98	0.99	063		1.01	1.04
	061	1.00	1.00	40YR/YRM	060	0.96	1.03
28RH	060	0.97	0.96	40YAM	060	0.99	1.02
28SL	061	1.00	1.00				

See notes on page 14.

# Detailed Cooling Capacities\* cont'd

Evaporator		CONDENSER ENTERING AIR TEMPERATURES °F														
Air		85			95			105			115			125		
CFM	E W B	Capacity MBtuht†		Total System	Capacity MBtuht†		Total System	Capacity MBtuht†		Total System	Capacity MBtuht†		Total System	Capacity MBtuht†		Total System
		Total	Sens‡	KW**	Total	Sens‡	KW**	Total	Sens‡	KW**	Total	Sens‡	KW**	Total	Sens‡	KW**
<b>38TG060-31 Outdoor Section With 28RDS/RNS061 Indoor Section</b>																
1750	72	64.5	31.6	6.86	60.9	30.2	7.26	57.2	28.9	7.63	53.5	27.5	8.00	49.8	26.2	8.35
	67	58.6	39.6	6.57	55.3	38.2	6.94	51.9	36.8	7.28	48.5	35.4	7.62	45.1	34.1	7.94
	62	53.0	47.3	6.30	49.9	45.8	6.63	46.8	44.1	6.95	43.7	42.4	7.26	40.7	40.4	7.55
	57	49.9	49.9	6.13	47.5	47.5	6.49	45.2	45.2	6.83	42.8	42.8	7.18	40.3	40.3	7.53
2000	72	65.9	33.0	7.04	62.1	31.6	7.43	58.3	30.2	7.81	54.4	28.8	8.17	50.5	27.5	8.52
	67	59.9	42.0	6.74	56.4	40.6	7.11	52.9	39.1	7.46	49.3	37.7	7.80	45.8	36.3	8.11
	62	54.2	50.4	6.45	50.9	48.6	6.79	47.7	46.7	7.12	44.6	44.5	7.43	41.8	41.8	7.77
	57	51.9	51.9	6.34	49.4	49.4	6.71	46.9	46.9	7.07	44.3	44.3	7.42	41.8	41.8	7.76
2175	72	66.6	33.9	7.14	62.7	32.5	7.54	58.8	31.1	7.92	54.9	29.8	8.28	50.9	28.3	8.63
	67	60.6	43.6	6.84	57.0	42.1	7.22	53.4	40.7	7.57	49.7	39.3	7.90	46.1	37.9	8.23
	62	54.8	52.2	6.56	51.5	50.3	6.90	48.3	48.1	7.23	45.3	45.3	7.57	42.6	42.6	7.91
	57	53.2	53.2	6.47	50.6	50.6	6.85	48.0	48.0	7.21	45.3	45.3	7.57	42.6	42.6	7.92
2250	72	66.9	34.3	7.18	63.0	32.9	7.58	59.0	31.5	7.96	55.0	30.1	8.33	51.0	28.7	8.67
	67	60.9	44.3	6.89	57.2	42.8	7.26	53.6	41.4	7.62	49.9	39.9	7.95	46.2	38.5	8.27
	62	55.1	53.0	6.60	51.8	50.9	6.95	48.5	48.5	7.28	45.7	45.7	7.63	43.0	43.0	7.98
	57	53.7	53.7	6.53	51.1	51.1	6.91	48.4	48.4	7.27	45.7	45.7	7.64	43.0	43.0	7.98

Multipliers for Determining the Performance With Other Indoor Sections

Indoor Section	Size	Cooling		Indoor Section	Size	Cooling	
		Capacity	Power			Capacity	Power
28HQS/VQS	060	0.96	0.94	40LT	060	0.98	0.97
28RC/RU	057	0.98	0.97	40QBS/QHS	060	0.99	1.05
	060	0.99	0.99		062	0.99	1.02
28RDS/RNS	057	0.96	0.96		063	1.00	1.04
	060	1.00	0.99	40QBS &			
	061	1.00	1.00	315016-402	005	1.04	1.05
28RH	060	0.96	0.96	40YR/YRM	060	0.97	1.03
28SL	061	1.00	1.00	40YAM	060	1.01	1.02

\*Detailed cooling capacities are based on indoor and outdoor unit at the same elevation and connected by 25 (7.62m) ft of tubing. If other than 25 (7.62m) ft of tubing is used and/or indoor unit is located above outdoor unit, a slight variation in capacity may occur.

†Total and sensible capacities are net capacities. Blower motor heat has been subtracted.

‡Sensible capacities shown are based on 80 F (27 C) entering air at the indoor coil. For sensible capacities at other than 80 F (27 C), deduct 835 Btu/h (245 KW) per 1000 Cfm (480 L/S) of indoor coil air for each degree below 80 F (27 C), or add 835 Btu/h (245 KW) per 1000 Cfm (480 L/S) of indoor coil air per degree above 80 F (27 C).

When the required data falls between the published data, interpolation may be performed.

\*\*Unit KW is total of indoor and outdoor unit KW's.

# Typical installation

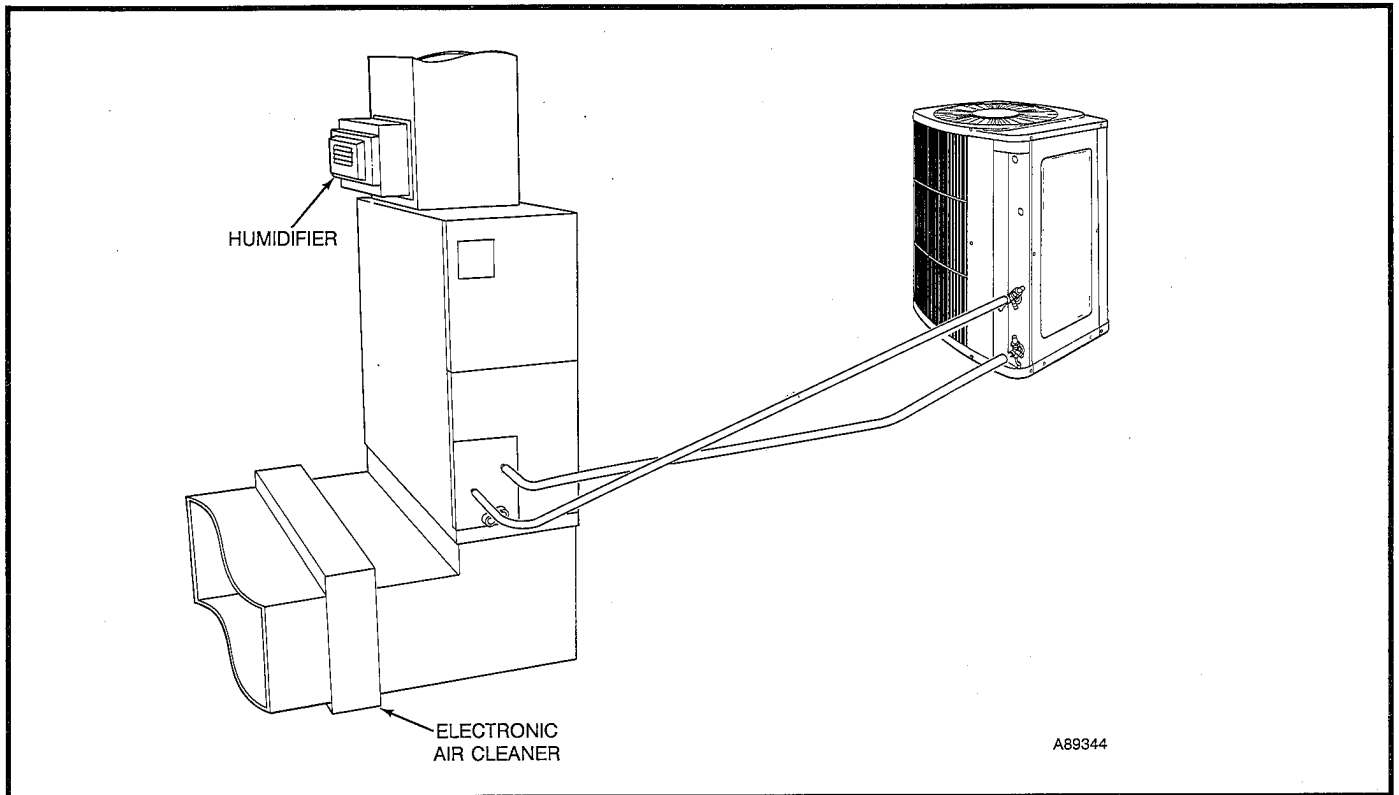

## System Design

1. Intended for outdoor installation with free air inlet and outlet. Outdoor fan external static pressure available is less than 0.01 ins. water column.
2. Minimum outdoor operating air temperature without low ambient operation accessory is 55 F (12.8 C).
3. Maximum outdoor operating air temperature is 125 F (51.7 C).
4. For reliable operation, unit should be level in all horizontal planes.
5. Maximum elevation of indoor coil above or below base of outdoor unit is: indoor coil above = 50 ft. Indoor coil below = 150 ft. (see items 6 and 7 following)
6. For interconnecting refrigerant tube lengths greater than 50 ft, consult Long-Line Application Guideline available from equipment distributor.
7. Crankcase heater required when interconnecting refrigerant tube length exceeds 50 ft.
8. Not more than 3 ft of refrigerant tube should be buried in the ground. If necessary to bury tubes under a sidewalk, provide a minimum 6 in. vertical rise to the valve connections at the unit.
9. Use only copper wire for electric connection at unit. Aluminum and clad aluminum are not acceptable for the type of connector provided.
10. Mixmatches of indoor coil capacity more than one size larger than outdoor unit capacity may result in inadequate indoor comfort.



Manufacturer reserves the right to discontinue, or change at any time, specifications or designs without notice and without incurring obligations.