



CANNON
SECURITY PRODUCTS

**TV Mount Wall Safe
OWNERS MANUAL**

Rev (9/13)

Index

Safe Information	Pg. 2
Warning	
Standard Features	
Installation/Mounting	Pg. 3
Set Up	Pg. 4
Opening the Door with the Key	
Installing the Batteries	
Opening the Door with the Keypad	
Lock Out (Wrong Try Penalty)	
Changing the Access Codes	
Locking/Closing the Door	
Warranty	Pg. 6

Unit Information/Record

DO NOT LOCK THIS IN YOUR SAFE

Important: Taking the time to fill out the information below and stapling a copy of your receipt to this manual will help expedite any service needs.

(888) 220-1116

Purchased From: _____

Purchased Date: _____

Serial Number: _____

Key Number: _____

Safe Information

Warning

- Install safe before using.
- After installing, change the default factory codes.
- Don't put emergency key(s) or manual in the safe.

Standard Features

- TV Mount for TV's holds up to 65 inches and 80lbs. Maximum VESA of 400 x 400.
- Hidden storage compartment.
- Quick drop down access door.
- Two user access codes.
- Lock out after ten (10) wrong entries for three (3) minutes.
- Electronic or Mechanical Access.
- LED Lighted Compartment.

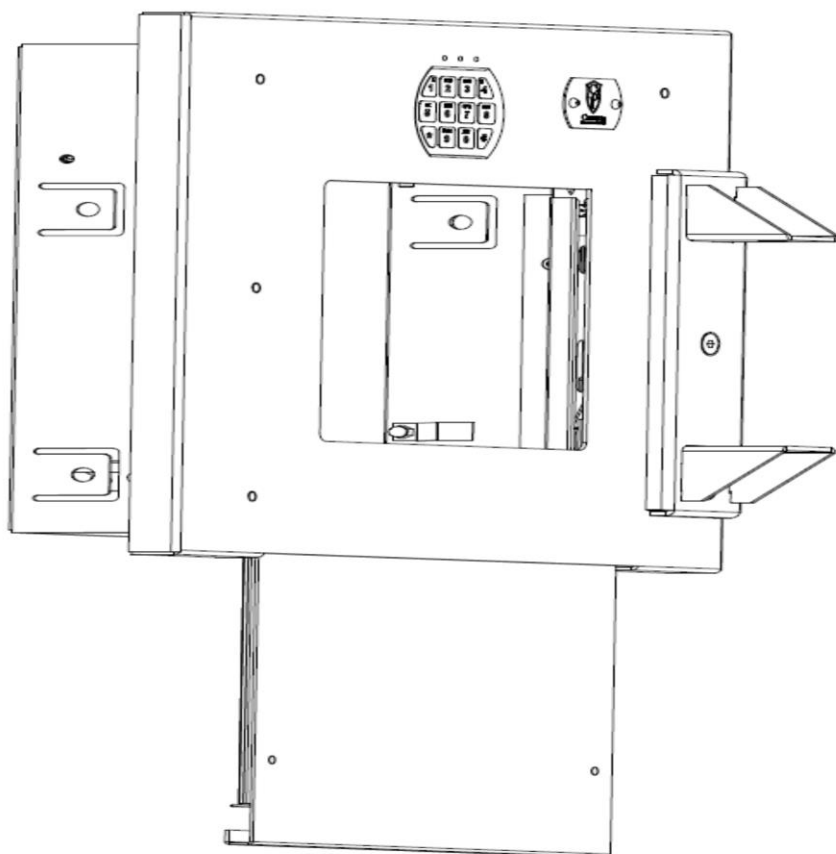

Included Hardware

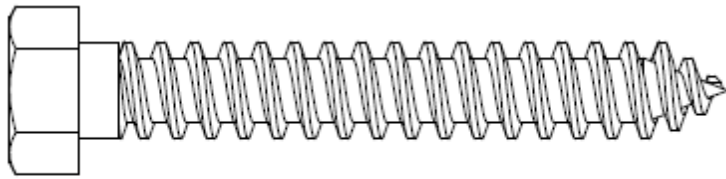

(A) WOOD SCREW (X4)



(B) PLASTIC SLEEVE



(C) M4 X 30 SCREW (4X)

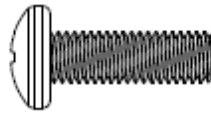

(D) M5 X 15 SCREW (4X)



(E) M5 X 30 SCREW (4X)

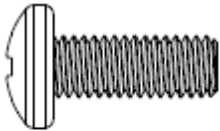

(F) M6 X 15 SCREW (4X)

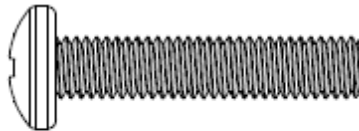

(G) M6 X 30 SCREW (4X)

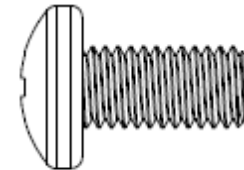

(H) M8 X 15 SCREW (4X)

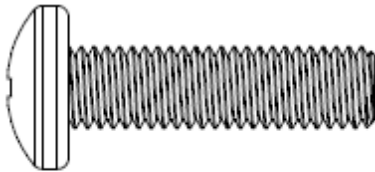

(I) M8 X 30 SCREW (4X)

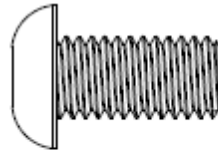

(J) M8 X 16 BUTTON HEAD SOCKET SCREW (2X)

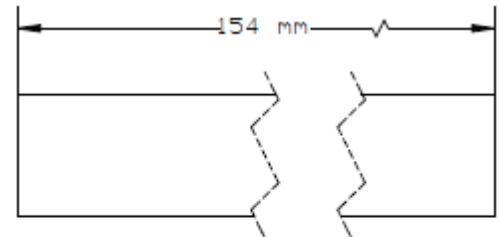

(K) SHAFT

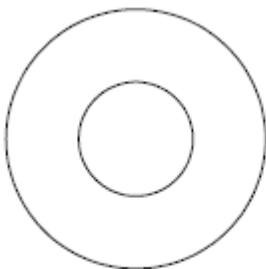

(L) 3/8" FLAT WASHER (4X)



(M) M6 FLAT WASHER

Mounting the Wall Safe

The Wall Safe can be mounted into a standard residential wall with a depth of at least 7.88 inches and a wall area of at least 22.84 inches (horizontal position) X 26.78 inches (vertical position).

- Make a hole in the wall that is approximately 14.37 inches X 14.37 inches.
- Carefully place the safe into the wall. Don't forcefully insert, the unit should slide into the opening easily.

Note: There should be a .25 inch gap between the safe and wall.

- Open the door and locate the 4 mounting tabs (2 on each side of walls). Mark holes for pre-drilling.
- Remove the safe and pre-drill holes at the marked locations.
- Reinsert safe into the wall and secure it with four (4) wood screws (A) and four (4) 3/8" flat washer (L).

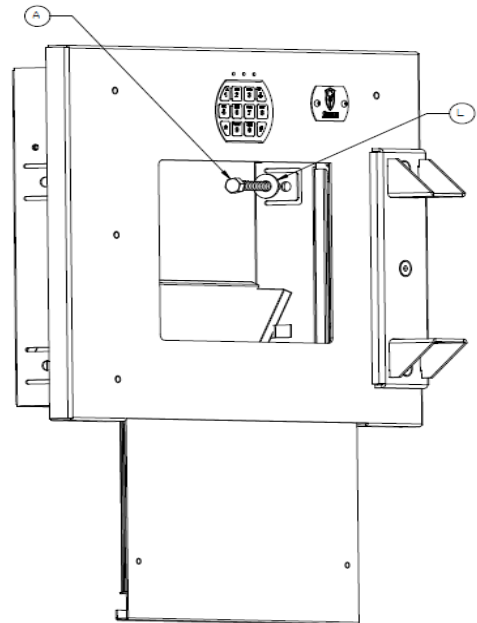
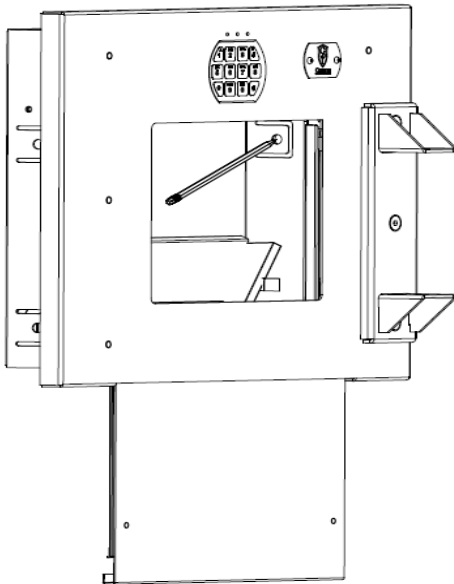

Installing the TV Mount Arm

The TV Wall Safe requires the TV arm to be attached after installation. Locate the TV arm, Shaft (K), and two (2) M8x16 Button Head Socket Screws (J) in preparation of the installation.

- Insert the end of the TV arm into the mounting bracket on the safe (as pictured below).
- While holding the TV arm in the mounting bracket on the safe, insert the Shaft (K) and use the two (2) M8x16 Button Head Socket Screws (J) to secure the TV arm to the wall safe. **Use caution not to over tighten and/or strip the heads of the screws.**

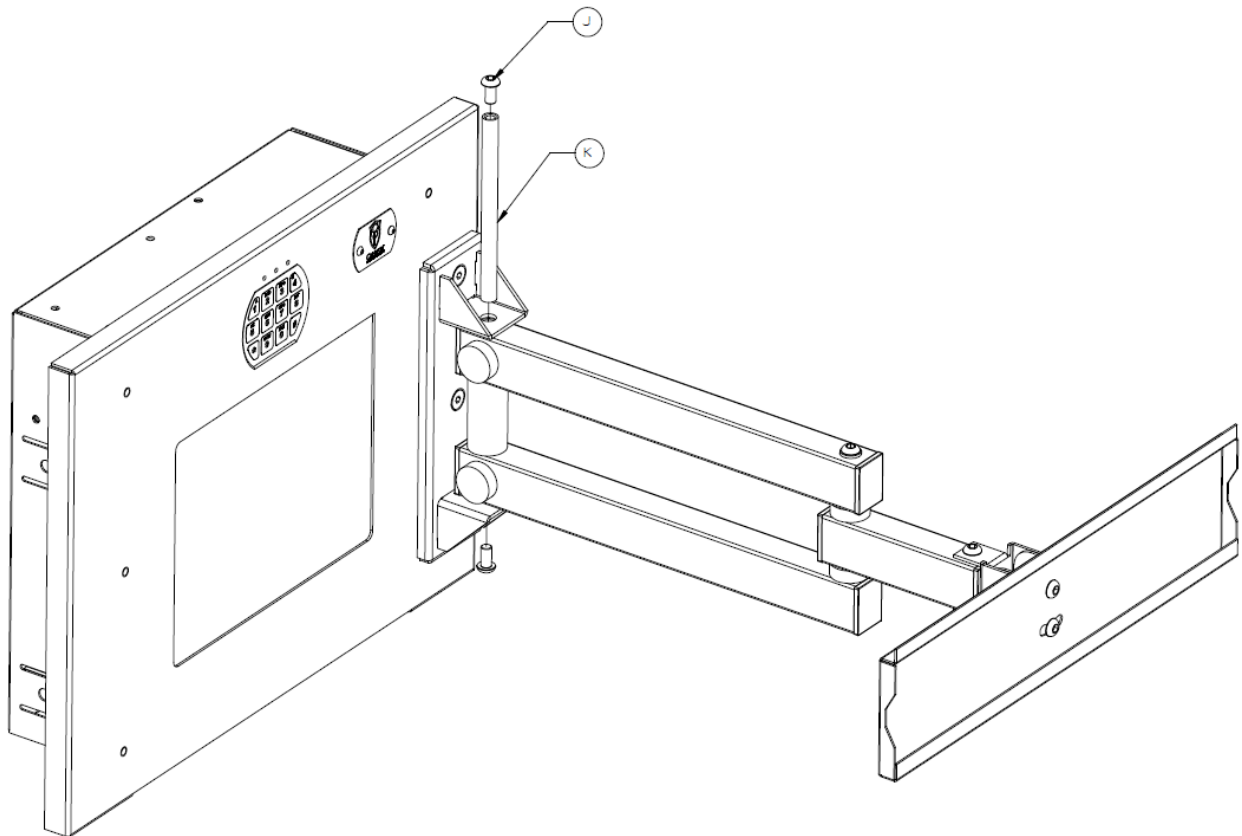

Fitting the Brackets to the TV

Installation of the TV brackets may require the use of Plastic Sleeves (B) if the back of the TV is not flat or the mounting holes are recessed. Locate the TV brackets, M6 Flat Washers (M), Screws (D, E, F, G, H, or I), and Plastic Sleeves (B).

- Choosing the scw length and diameter.
 - Hand thread screws into the threaded inserts on the back of the TV to determine the correct screw diameter and length. **Important: The incorrect screws can cause potential damage to person or property.** See image below to the left:

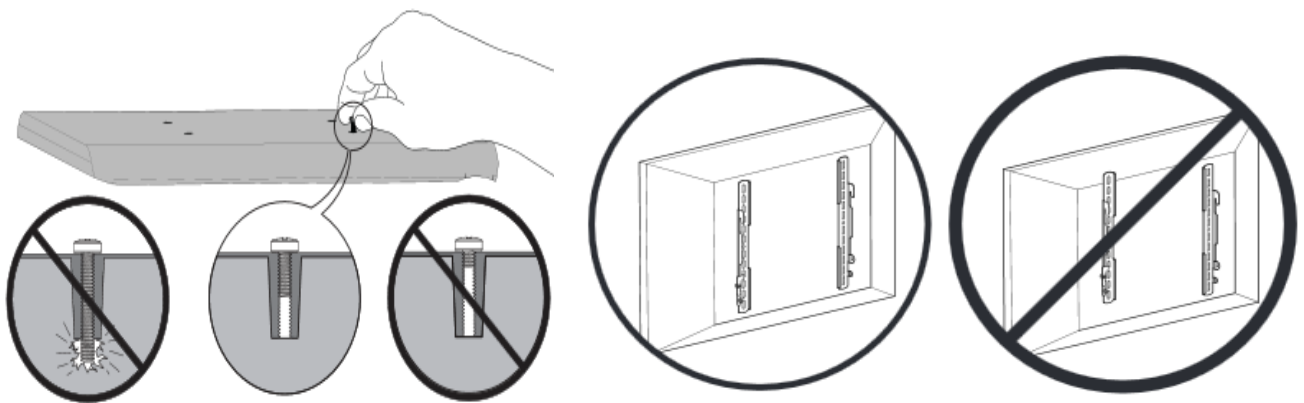

- Line up the holes on the TV brackets to the mounting holes on the back of the TV and assure the TV brackets are level, see image above to the right. **Important: If the TV brackets do not lay flat against the TV or the mounting holes are recessed, use the four (4) Plastic Sleeves (B) between the TV brackets and TV.**

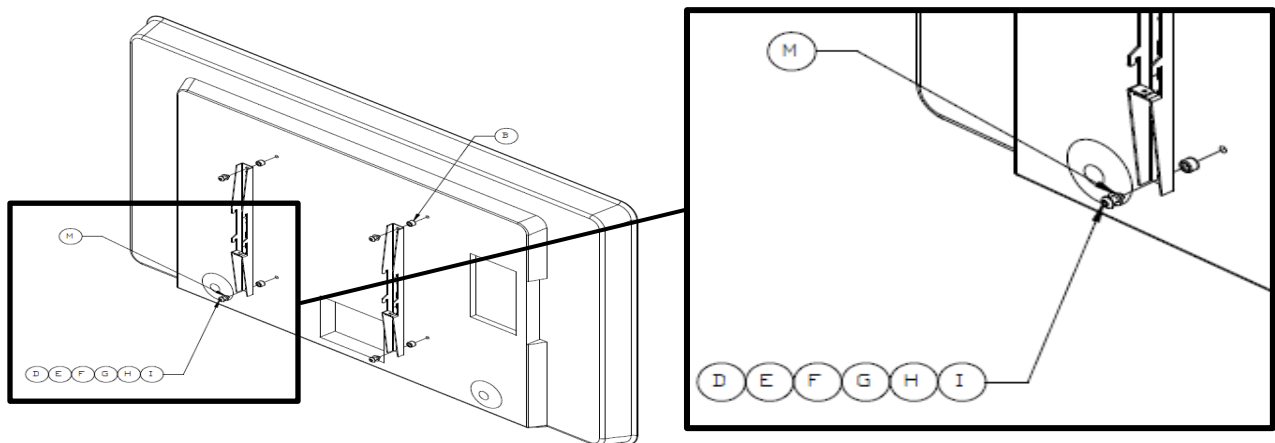

- After lining up the holes, install the needed hardware as pictured above. **Important: Do not over tighten the screws.**

Mounting the TV to the Wall Safe

CAUTION: YOU WILL NEED INSTALLATION ASSISTANCE WITH THESE STEPS.

- Lift TV onto bracket as shown in Diagram 1, making sure it is secure to the top lip of the bracket.
- Center TV onto the bracket as shown in Diagram 2.
- Tighten set screw to bottom of bracket as show in Diagram 3.

Diagram 1

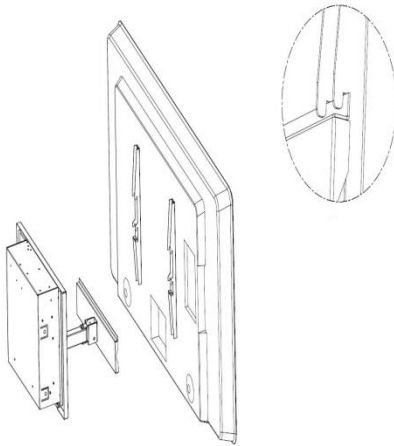

Diagram 2

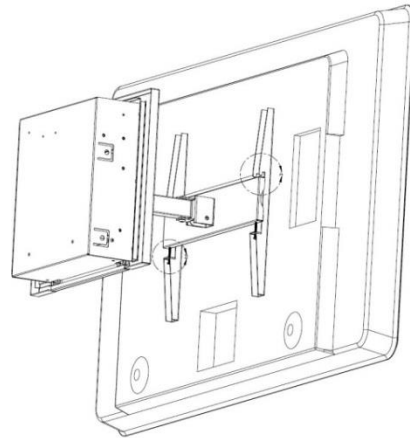
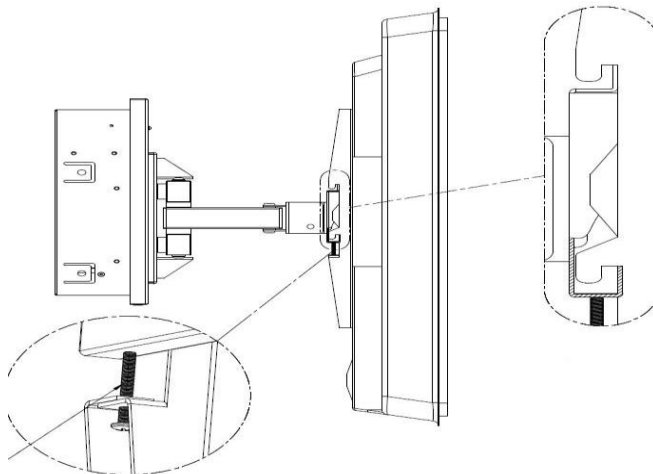

Diagram 3



Setting Up the Wall Safe

Opening the Door with the Key

In an emergency or electronic failure, the safe can be accessed by using a backup key. The key slot is hidden behind the logo name plate on the front of the safe.

- Use an allen wrench to unscrew the logo plate.
- Insert the key into the lock and turn counter-clockwise to open.

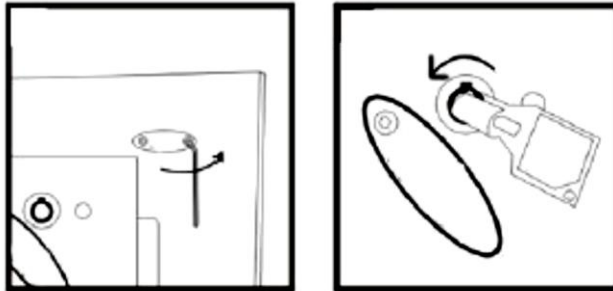

Installing/Replacing the Batteries

With the door in the open position, locate the black battery compartment cover inside the safe on the roof/top.

- Remove the black battery compartment cover by pressing the tab to the left and pulling down.

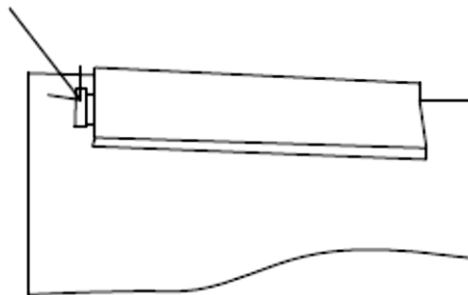

- The battery tray will drop down. Install four (4) new AA Alkaline Batteries and reinsert the battery tray with '**INSERT INWARD**' facing into the compartment.

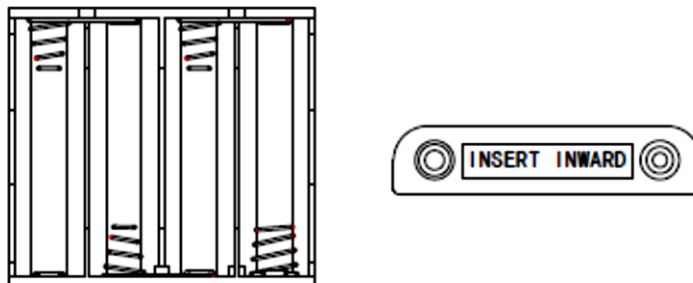

- Reinstall the black battery compartment cover.

Opening the Door with the Keypad

If opening for the first time, the default access codes are '1234' and '123456'. **Batteries must be installed to work.**

- Enter the current one (1) to eight (8) digit code followed by the (#) button.
- If the code is correct, the door will open automatically.

Note:

- If the (*) button is pushed when entering the code, the process starts over.
- If there are five (5) beeps with yellow LED flashes the code entered is not recognized as the current code.

Lock Out (Wrong Try Penalty)

After ten (10) wrong entries the lock will go into lock out for three (3) minutes. Do not press any buttons during the lockout period, it will restart the three (3) minute lock period.

Changing the Access Codes

To program your access codes, follow the instructions below:

- **Setting Main Code Number:**
 - Open the door.
 - Press the **'RESET'** button in the upper right corner of the inside of safe. System will beep twice and yellow LED lights up.
 - Input the new one (1) to eight (8) digit code followed by the (*) button.
 - Your new code is now recorded.
- **Setting secondary code number:**
 - Open the door.
 - Press the **'0'** button twice (0-0) on the keypad.
 - Press the **'RESET'** button in the upper right corner of the inside of safe. System will beep twice and yellow LED lights up.
 - Input the new one (1) to eight (8) digit code followed by the (*) button.
 - Your new code is now recorded.

Note: When entering the new code, the (*) button is not active.

Locking/Closing the Door

- Slowly lift up on the bottom of the door.
- Push upwards firmly until door lock engages.

Warranty

1. Cannon Security Products, LLC (the "Company") warrants to the original consumer (the "Purchaser") that this product (the "Product") will be free from defects in workmanship and materials for a period of ninety (90) days from the date of purchase. These warranties are not assignable or transferable to any other person.
2. Any damage to the product as a result of misuse, tampering, abuse, neglect, accident, improper installation, modification, unauthorized service, destruction, or the alteration of the serial number, or use violative of the instructions furnished by the Company will void this warranty.
3. The sole responsibility of the Company shall be limited to the repair or replacement (in its sole discretion) of any component of the Product which fails to conform to this warranty at no cost to the purchaser for a period of ninety (90) days from the date of original purchase.
4. Contact the Company directly to obtain service under this warranty. If it becomes necessary to send a defective product to the Company, a Return Authorization Number must first be obtained from the Company.
5. Products shipped without prior Return Authorization and Return Authorization Number may not be accepted, and the Company will not be responsible for their disposition and/or cost of return to the purchaser.
6. The Company will not assume any responsibility for any loss or damage incurred in shipping. All return authorized products should include a copy of the original invoice in order that this warranty may be honored.
7. This warranty is not an insurance policy. The Company is not responsible for damage to or theft of the Product or its contents.
8. The obligation of Company under this warranty is contingent upon proper use of the Product, and shall not apply to Products, or parts or components thereof, which have been put in unusual or extreme environments or any damage caused by an act of God or force of nature. Modifying or tampering with the Product, which might affect the Product's use, voids this warranty.
9. Without limitation, this warranty specifically excludes any liability for defects or damages caused by, or aggravated by, human error or the use of unauthorized parts or components.
10. We recommend that the enclosed warranty card be completed in full, and returned to the Company within ten (10) days of the original date of purchase to validate this warranty.
11. Any implied warranties which the Purchaser may have are limited to the duration of the warranties described above. There are no further warranties which extend or apply beyond the face hereof, and the Company expressly disclaims and excludes any and all warranties of merchantability or fitness for a particular purpose. Some states do not allow limitations on how long an implied warranty lasts, so the above limitation may not apply to you.
12. Repair or replacement shall be the sole remedy for the Purchaser under this warranty. The Company shall not be liable for any direct, indirect, incidental or consequential damages, losses or expense arising from the use or misuse of the Product. Some states do not allow the exclusion or limitations of incidental or consequential damages, so the limitation may not apply to you.
13. This warranty gives you specific legal rights, and you may also have other rights which vary from state to state.

WWW.CANNONSEcurityPRODUCTS.COM